

EVOLUTION OF HOST SPECIFICITY DRIVES REPRODUCTIVE ISOLATION AMONG RNA VIRUSES

Siobain Duffy,^{1,2,3} Christina L. Burch,^{3,4} and Paul E. Turner^{1,5}

¹*Department of Ecology and Evolutionary Biology, Yale University, New Haven, Connecticut 06520*

²*E-mail: smd16@psu.edu*

³*Department of Biology, University of North Carolina, Chapel Hill, North Carolina 27599*

⁴*E-mail: cburch@bio.unc.edu*

⁵*E-mail: paul.turner@yale.edu*

Received May 14, 2007

Accepted July 18, 2007

Ecological speciation hypotheses claim that assortative mating evolves as a consequence of divergent natural selection for ecologically important traits. Reproductive isolation is expected to be particularly likely to evolve by this mechanism in species such as phytophagous insects that mate in the habitats in which they eat. We tested this expectation by monitoring the evolution of reproductive isolation in laboratory populations of an RNA virus that undergoes genetic exchange only when multiple virus genotypes coinfect the same host. We subjected four populations of the RNA bacteriophage $\phi 6$ to 150 generations of natural selection on a novel host. Although there was no direct selection acting on host range in our experiment, three of the four populations lost the ability to infect one or more alternative hosts. In the most extreme case, one of the populations evolved a host range that does not contain any of the hosts infectible by the wild-type $\phi 6$. Whole genome sequencing confirmed that the resulting reproductive isolation was due to a single nucleotide change, highlighting the ease with which an emerging RNA virus can decouple its evolutionary fate from that of its ancestor. Our results uniquely demonstrate the evolution of reproductive isolation in allopatric experimental populations. Furthermore, our data confirm the biological credibility of simple “no-gene” mechanisms of assortative mating, in which this trait arises as a pleiotropic effect of genes responsible for ecological adaptation.

KEY WORDS: Assortative mating, bacteriophage, experimental evolution, host shift, parapatry.

The origin of species has captured the imagination of evolutionary biologists from the time of Darwin (1859), through the modern synthesis (Dobzhansky 1937; Mayr 1942), until today (Schemske 2000). Yet scientists are still elucidating and debating the relative importance of different mechanisms for speciation (Coyne and Orr 2004). In the traditional Dobzhansky–Muller model of speciation, genetic incompatibilities are thought to accumulate over time between allopatric, spatially separated populations, eventually resulting in postmating barriers to reproduction such as hybrid inviability and sterility (Dobzhansky 1937; Muller 1939, 1940, 1942). Although natural selection can play a role in the evolution

of genetic incompatibilities, in this model of speciation the role of natural selection in the evolution of reproductive isolation is not direct. That is, reproductive isolation evolves as a consequence, not of the phenotypes, but of the genotypes produced by natural selection (Templeton 1980; Doebeli et al. 2005).

There is, however, a growing consensus that reproductive isolation often evolves as a direct consequence of the phenotypes produced by natural selection. In this scenario, natural selection could facilitate speciation in both sympatry and allopatry (Schluter 2001; Coyne and Orr 2004). Of particular interest is the process of ecological speciation, in which assortative mating evolves as a

pleiotropic consequence of divergent natural selection for ecologically important traits (Schluter 2001). For instance, assortative mating should evolve as a pleiotropic consequence of selection for divergent habitat preference as long as organisms mate in their preferred habitat. In this simplest mechanism of ecological speciation, the only genes required for the evolution of reproductive isolation are genes involved in ecological adaptation. Because no genes for mate choice are required for the process of ecological speciation, it has been referred to as a “no-gene” mechanism of assortative mating (Rice 1987; Coyne and Orr 2004).

Host shifts may represent the most likely scenario for assortative mating to arise via a no-gene mechanism because mate choice is often determined by host preference. For example, assortative mating between host races of the apple maggot fly, *Rhagoletis pomonella*, may have evolved via selection acting directly on host preference (Feder et al. 1998; Filchak et al. 2000). In *Rhagoletis*, a new host race emerged following the introduction of apples to North America. Regardless of whether the host race formation occurred in allopatry before the introduction of apples (Feder et al. 2003) or in sympatry after the introduction, the divergent host preference, itself, may have conferred an ecological adaptation by allowing the new host race to escape resource competition on hawthorns, the ancestral host plant (Feder et al. 1998). Thus, assortative mating (host preference) and ecological adaptation in *Rhagoletis* might have a shared genetic basis. However, the genetic intractability of ecological models such as *Rhagoletis* has made it difficult to confirm that the same gene underlies both traits. Investigations of more tractable phytophagous insects have localized genes involved in host preference and host performance to shared regions of the genome (Hawthorne and Via 2001), but no study has confirmed that an individual locus affects both traits.

Evolution experiments with phytophagous insects that attempted to demonstrate the plausibility of no-gene models of assortative mating have also met with limited success. Although numerous laboratory evolution experiments have demonstrated the evolution of moderate levels of assortative mating in response to selection for habitat preference (e.g., Rice and Salt 1990; Rice and Hostert 1993), none has achieved complete reproductive isolation. To date, the only laboratory evolution experiments to achieve high levels of reproductive isolation (Leu and Murray 2006) selected directly for assortative mating rather than ecological adaptation.

Viruses share the key characteristic that has made phytophagous insects popular models for studying ecological speciation—viruses engage in sexual reproduction only when two or more viruses coinfect the same host (Delbrück and Bailey 1946; Malmberg 1977). Therefore, mate choice in viruses is determined by host specificity (relative ability for a virus to infect one or more host types). However, viruses offer three experimental advantages over insects for monitoring speciation processes in the laboratory. First, viruses evolve rapidly, facilitating the direct empirical

observation of speciation, which is more difficult in most other systems (Rice and Hostert 1993). In particular, the high per-nucleotide mutation rates of RNA viruses (Drake 1993) provide extensive genetic variation that fuels evolution by natural selection, making the study of reproductive isolation and speciation especially feasible (Holmes 2004). Second, in viruses it is possible to identify the individual mutations responsible for host performance and host specificity through whole genome sequencing and classical genetic crosses. Last, it is easy to measure the fitness effects of the individual mutations responsible for reproductive isolation to determine whether these changes occurred via natural selection versus genetic drift.

Previous experiments have shown that viral adaptation to a single host is often accompanied by a reduced ability to infect alternative hosts (reviewed in Fenner and Cairns 1959; Ebert 2000). For example, adaptation of the bacteriophage ϕ X174 to *Salmonella enterica* was accompanied by a reduced ability to infect *Escherichia coli* (Crill et al. 2000). One might logically conclude, therefore, that adaptation to a novel host—a host that is not infectible by the wild-type virus—should often produce an evolved virus that no longer infects the ancestral host, so that the host ranges of the closely related wild-type and evolved viruses no longer overlap. However, this conclusion has yet to be experimentally validated. To our knowledge, no study has shown that viral adaptation to a single host led to nonoverlapping host ranges between closely related viruses.

We examined the plausibility of the no-gene model of ecological speciation by monitoring the evolution of bacterial host specificity in lineages of the RNA bacteriophage ϕ 6 during selection for improved performance on a novel host. Phage ϕ 6 possesses all of the general advantages of virus model systems, and ϕ 6 has proven to be a tractable experimental system for answering evolutionary questions that are difficult to address in natural populations (e.g., Chao et al. 1992; Turner and Chao 1998; Burch and Chao 2000).

Materials and Methods

STRAINS AND CULTURE CONDITIONS

An expanded-host-range genotype (ϕ 6_{broad}; mutant E8G [Duffy et al. 2006]) was obtained as a spontaneous mutant of the wild-type ϕ 6 (ϕ 6_{wt}; strain ATCC-21781-B1, American Type Culture Collection, Manassas, VA). Duffy et al. (2006) examined 15 different *Pseudomonas* hosts and determined that four bacteria comprise the known host range of ϕ 6_{wt}: *Pseudomonas syringae* pathovar *phaseolicola* HB10Y (ATCC-21781), and *P. syringae* pathovars *persicae*, *savastanoi*, and *tagetis* (generously provided by G. Martin, Cornell University, Ithaca, New York). The mutant ϕ 6_{broad} infects these same four bacteria, and additionally can infect two novel hosts: *P. syringae* pv. *tomato* (G. Martin) and

P. pseudoalcaligenes ERA (East River isolate A; generously provided by L. Mindich, Public Health Research Institute, Newark, New Jersey).

Detailed methods are previously described (Duffy et al. 2006). Briefly, we used LC medium (Luria Bertani broth at pH 7.5) to culture bacteria. Phage were grown by mixing viruses with a bacterial lawn in 3 mL of LC top agar (0.7% agar), overlaid onto an LC plate (1.5% agar). Incubation of all cultures and plates occurred at 25°C. Phage populations and single plaques were archived in 40% glycerol/ 60% LC broth and stored at -20°C.

EVOLUTION EXPERIMENTS

We used phage $\phi 6_{\text{broad}}$ to found four replicate populations (E1–E4) subjected to experimental evolution via plaque growth on *P. pseudoalcaligenes* ERA lawns (seeded using $\sim 2.5 \times 10^8$ stationary-phase bacteria, measured in colony-forming units). Each day, an evolving lineage was allowed to form ~ 300 plaques (always between 150 and 600 plaques), where each plaque initiates from a single virus particle. Viral titers were thus measured in plaque-forming units. After 24-h incubation, plaques were harvested and filtered to obtain a bacteria-free lysate containing the virus progeny for the lineage. To maintain the population bottleneck size of ~ 300 individual viruses, the lysate was subsequently diluted and plated again in the presence of naïve (unevolved) bacteria. Use of naïve bacteria that were freshly grown from frozen stock prevented evolution of bacterial resistance to phage, as well as any possibility for coevolution between bacteria and phage. The 24-h propagation scheme was repeated for 30 consecutive days, to achieve 30 passages per virus lineage. As overnight plaque growth corresponds to approximately five generations of viral evolution, the populations experienced ~ 150 generations of experimental evolution (30 passages \times 5 generations per passage).

HOST-RANGE DETERMINATION

Over the course of the experiment we monitored the host range of individual genotypes in each population by plating phages on lawns containing mixtures of the unselected hosts *P. syringae* pathovar *phaseolicola* (the standard laboratory host) and *P. syringae* pathovar *tomato*. In contrast to the $\phi 6_{\text{broad}}$ ancestor that formed clear plaques by killing both hosts on these plates, evolved phages that lost the ability to infect one of these hosts formed turbid plaques, and evolved phages that lost the ability to infect both hosts failed to form plaques at all. This method revealed whether an experimental lineage became dominated by narrowed host-range genotypes.

To more closely examine host range of an evolved virus clone, we first obtained a high-titer lysate ($\sim 10^{10}$ virus particles per mL) of the clone on the selected host, *P. pseudoalcaligenes* ERA. Using the method described by Duffy et al. (2006), samples from the lysate containing $\sim 10^3$ virus particles were then spotted onto

lawns of the six different bacterial hosts comprising the host range of the common ancestor, $\phi 6_{\text{broad}}$. These assay plates were incubated for up to 48 h, and the method was repeated three times using independently grown host bacteria cultures. Plaque formation indicated that the host bacterium was within the virus' host range. If the results were ambiguous, host range was confirmed by standard plating of $\sim 10^2$ viruses on a bacterial lawn to visualize individual plaques.

Using this method, from each end point (day 30) evolved population we isolated at random and plaque-purified a single clone that possessed the majority phenotype observed in the population. This process yielded clones $\phi 6_{\text{E1narrow}}$, $\phi 6_{\text{E2}}$, $\phi 6_{\text{E3narrow}}$, and $\phi 6_{\text{E4narrow}}$ from populations E1, E2, E3, and E4, respectively. In addition, we isolated and plaque-purified a random clone from end point populations E1, E3, and E4 that showed the minority broad host-range phenotype: $\phi 6_{\text{E1broad}}$, $\phi 6_{\text{E3broad}}$, and $\phi 6_{\text{E4broad}}$. Last, for some analyses it was necessary to isolate clone $\phi 6_{\text{E1narrow}(\text{day}20)}$, a narrowed host range virus from population E1 at day 20 of the study.

FITNESS MEASURES

Fitness of an evolved test phage was determined by estimating its growth rate on *P. pseudoalcaligenes* ERA, relative to a reference strain of $\phi 6$ (paired growth assays [Turner and Chao 1998; Duffy et al. 2006]). This reference strain is denoted "ERA common competitor," or ECC. ECC is descended from $\phi 6_{\text{wt}}$ but has a mutation that allows it to infect the relevant host range of the evolved viruses, as well as host *P. syringae* pv *atrofaciens*.

The fitness assay began with mixing together a test phage and ECC at a 1:1 ratio in LC medium. A diluted sample of this initial mixture was then plated on a mixed-host lawn containing a 20:1 ratio of *P. syringae* pv *phaseolicola* to *P. syringae* pv *atrofaciens*. On the mixed-host lawn ECC produced clear plaques, whereas a test phage produced turbid plaques because it could not infect *P. syringae* pv *atrofaciens*. In this way, the plaques appearing on the mixed-host lawn after 24 h were used to estimate the true ratio of test phage to ECC in the initial mixture (R_0) at the beginning of the fitness assay. A diluted sample of the initial mixture containing ~ 200 plaque-forming virus particles total was also plated on *P. pseudoalcaligenes* ERA. After 24 h, the resulting ~ 200 plaques were harvested and filtered to obtain a bacteria-free lysate containing the progeny of the two viruses. A diluted sample of the lysate was then plated on a mixed-host lawn to estimate the ratio of test virus to ECC after 24 h of growth on ERA (R_{24}). Thus, fitness (relative growth rate) was determined on ERA, but the relative ratio of viruses was tracked by platings on the mixed-host lawns. Fitness (W) is the ratio of the two observed ratios: $W = R_{24}/R_0$ (Duffy et al. 2006). We used $\log W$ in all statistical analyses, because (1) this approach is preferred in microbial evolution experiments (Bennett et al. 1990; Chao et al. 1992; Burch and

Chao 2000), and (2) $\log W$ exhibits homogeneous variance. All test viruses were competed six times versus ECC. A two-tailed t -test (Microsoft Excel, Redmond WA) was used to compare the fitnesses of broad and narrow host-range genotypes drawn from the same experimental population.

When an evolved virus strain was observed to no longer infect the standard laboratory host *P. syringae* pv *phaseolicola*, we were forced to use a modified version of the paired-growth assay to estimate its fitness. The alternate fitness assay employed $\phi 6_{E1\text{broad}}$ as the common competitor. As in the standard fitness assay, the test phage and the common competitor were compared for relative growth on *P. pseudoalcaligenes* ERA. To track ratios of viruses (R_0 , R_{24}) in these modified fitness assays, we used mixed-host lawns containing *P. syringae* pv *phaseolicola* and *P. pseudoalcaligenes* ERA in a 20:1 ratio. On these discriminative plates, the $\phi 6_{E1\text{broad}}$ common competitor formed clear plaques, whereas the evolved test phage formed turbid plaques because it failed to infect *P. syringae* pv *phaseolicola*.

As we employed multiple common competitors in our fitness assays, statistical analyses of fitness data involved only comparisons among strains that were assayed relative to the same reference strain.

SEQUENCING

Genomic RNA was extracted from high-titer lysates of the endpoint clones as previously described (Duffy et al. 2006). The $\phi 6$ genome consists of three double-stranded RNA segments, designated Small, Medium, and Large (Mindich 2006). The entire genomes (excepting the ends of each segment) were sequenced and deposited in Genbank (accession numbers DQ479436 to DQ479456).

GENETIC CROSSES

We used classic genetic crosses to identify which molecular substitution led to narrowed host range in an evolved virus. To perform a genetic cross, we placed $\sim 5 \times 10^8$ virus particles of each of two virus genotypes ($\sim 1 \times 10^9$ viruses total) into LC medium containing $\sim 2 \times 10^8$ exponentially growing *P. pseudoalcaligenes* ERA bacteria. Thus, the mixture resulted in a multiplicity of infection of roughly five viruses per bacterium. Here, the vast majority of cells experience coinfection by multiple viruses, which allows for reassortment: the formation of hybrid genotypes containing a combination of the RNA segments present in the two coinfecting parent viruses (Turner and Chao 1998). (We note that true recombination [template switching between RNA segments] is rare or nonexistent in $\phi 6$, allowing each of the three RNA segments to be treated as a single locus [Mindich et al. 1976].) After 40-min incubation to allow virus attachment to cells, a diluted sample of the mixture was plated to obtain a high-titer lysate containing the viral progeny. We then identified progeny with the narrow

host-range phenotype (growth restricted to *P. pseudoalcaligenes* ERA), double or triple plaque-purified single genotypes with both the broad and narrow host ranges, and sequenced the regions containing mutations to identify the hybrid genotypes. In this manner, we isolated narrow or broad host-range genotypes containing the relevant combinations of evolved RNA segments.

Results

We tested the plausibility of the no-gene mechanism of speciation by examining the consequences of adaptation to a novel host in laboratory populations of the RNA phage $\phi 6$, which infects a number of *Pseudomonas* species. We founded four replicate populations (E1–E4) with a broad host-range phage ($\phi 6_{\text{broad}}$) that differs from the wild-type ($\phi 6_{\text{wt}}$) only by the mutation E8G in the host attachment gene P3 (Duffy et al. 2006). This mutation confers the ability to infect two host strains that do not permit infection of $\phi 6_{\text{wt}}$, including the novel host *P. pseudoalcaligenes* ERA (Table 1). Each of the populations founded by $\phi 6_{\text{broad}}$ was subjected to selection on the novel host *P. pseudoalcaligenes* by plating the phage population on a lawn of the novel host, incubating for 24 h to allow individual phages to form plaques, harvesting progeny phages from ~ 300 of the resulting plaques, and plating these phages on a fresh lawn of the novel host. This cycle was repeated for 30 days, corresponding to ~ 150 virus generations. The presence of only a single host in the habitat ensured that selection was not acting directly on host range (i.e., host-use specificity; the mechanism by which viruses achieve assortative mating). Rather, if host specificity evolved, it could only occur as an indirect consequence of selection for improved performance on the novel host.

We gauged fitness improvement on the new host via paired-growth assays (see Methods). Here, a representative virus clone from each endpoint (generation 150) population was assayed for growth rate, relative to a common competitor virus. Results showed that after 150 generations of evolution on the novel host all four populations responded to selection, showing significantly higher fitness than the common ancestor, $\phi 6_{\text{broad}}$, on the novel host (Table 1).

By the end of the experimental evolution on the novel host, three populations became dominated by genotypes with a narrowed host range (Fig. 1). These data strongly suggest that narrowed host range genotypes were generally favored by selection, such that viruses featuring this trait either fixed or were on their way to fixation by generation 150. Individual narrow host-range genotypes isolated from populations E3 and E4 ($\phi 6_{E3\text{narrow}}$, $\phi 6_{E4\text{narrow}}$) lost the ability to form plaques on one of the six hosts (*P. syringae* pv *tomato*) within the host range of the ancestral phage $\phi 6_{\text{broad}}$ (Table 1). The narrow host-range genotype isolated from population E1 ($\phi 6_{E1\text{narrow}}$) lost the ability to form plaques on five hosts, including all four hosts within the host range of $\phi 6_{\text{wt}}$

Table 1. Host range of wild-type $\phi 6$ and the ancestral mutant ($\phi 6_{\text{broad}}$) used in experimental evolution, and changes in host range for a representative clone from each of four lineages evolved for ~150 generations on *Pseudomonas pseudoalcaligenes* ERA. Host range is also given for three $\phi 6$ genotypes derived from lineage E1. Fitness values are mean $\log W$ (with standard error) on *P. pseudoalcaligenes*, relative to a common competitor.

Hosts Infected	$\phi 6_{\text{WT}}$	$\phi 6_{\text{broad}}$	$\phi 6_{\text{E1narrow}}$	$\phi 6_{\text{E2}}$	$\phi 6_{\text{E3narrow}}$	$\phi 6_{\text{E4narrow}}$	$\phi 6_{\text{E1narrow}}(\text{day20})$	$\phi 6_{\text{E1broad+P8:A13T}}$	$\phi 6_{\text{E1broad+P3:G247A}}$
<i>P. syringae</i> pv <i>phaseolicola</i>	•	•	•	•	•	•	•	•	•
<i>P. syringae</i> pv <i>persicae</i>	•	•	•	•	•	•	•	•	•
<i>P. syringae</i> pv <i>savastanoi</i>	•	•	•	•	•	•	•	•	•
<i>P. syringae</i> pv <i>tagetis</i>	•	•	•	•	•	•	•	•	•
<i>P. syringae</i> pv <i>tomato</i>	•	•	•	•	•	•	•	•	•
<i>P. pseudoalcaligenes</i> ERA	•	•	•	•	•	•	•	•	•
$\log W$ on <i>P. pseudoalcaligenes</i> ^a	N/A	-0.34 ± 0.06	1.74 ± 0.25	1.20 ± 0.07	1.09 ± 0.05	0.98 ± 0.07	0.18 ± 0.05	ND	0.20 ± 0.06
$\log W$ on <i>P. pseudoalcaligenes</i> ^b									

^aMeasured relative to common competitor ECC.

^bMeasured relative to common competitor $\phi 6_{\text{E1broad}}$.

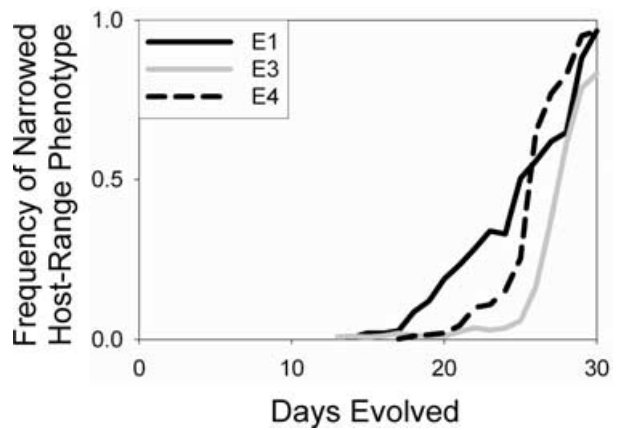

Figure 1. Appearance and spread of narrow host-range phenotypes during the evolution on the novel host *Pseudomonas pseudoalcaligenes* ERA. Narrowed host-range is defined as inability to infect one or more of the bacteria hosts within the host range of the ancestor. In three of four replicate populations founded by a broad host-range mutant of $\phi 6$, phenotypes arose that were unable to infect at least one of the hosts in the ancestral broad host range.

(Table 1). The disjoint host ranges of $\phi 6_{\text{E1narrow}}$ and $\phi 6_{\text{wt}}$ cause complete reproductive isolation between these genotypes, among the group of bacterial hosts $\phi 6$ is known to infect (Duffy et al. 2006).

To identify the individual mutations responsible for the narrow host-range phenotypes, we sequenced the genomes of one majority genotype with a narrow host range (e.g., $\phi 6_{\text{E1narrow}}$) and one minority genotype with a broad host range (e.g., $\phi 6_{\text{E1broad}}$) isolated from populations E1, E3, and E4 after 30 days of evolution (Genbank DQ479436-DQ479456, Fig. 2). From sequence data alone, it was possible to identify the individual mutation responsible for the narrow host range of $\phi 6_{\text{E3narrow}}$. The only mutation that differed between $\phi 6_{\text{E3narrow}}$ and $\phi 6_{\text{E3broad}}$ was the substitution of A31T in the host attachment gene P3 (Fig. 2, E3), unambiguously identifying this mutation as the sole cause of the narrow host-range phenotype. $\phi 6_{\text{E4narrow}}$ and $\phi 6_{\text{E4broad}}$ differed by this same mutation, A31T in P3, and by two additional mutations in P3, one synonymous and one nonsynonymous (Fig. 2, E4). Two observations suggest that the A31T mutation in P3 is also responsible for the narrow host range of $\phi 6_{\text{E4narrow}}$: (1) it is the only convergent mutation shared by $\phi 6_{\text{E3narrow}}$ and $\phi 6_{\text{E4narrow}}$, and (2) $\phi 6_{\text{E3narrow}}$ and $\phi 6_{\text{E4narrow}}$ show identical narrowed host ranges.

It was more difficult to identify the mutation responsible for the narrow host range of $\phi 6_{\text{E1narrow}}$ because this phage had acquired three nonsynonymous mutations since its divergence from the common ancestor of $\phi 6_{\text{E1narrow}}$ and $\phi 6_{\text{E1broad}}$: A13V in the nucleocapsid shell protein P8, and T47S and G247A in the host attachment gene P3 (Fig. 2, E1). An additional mutation was found in $\phi 6_{\text{E1narrow}}$, in the untranslated 3' region of the medium

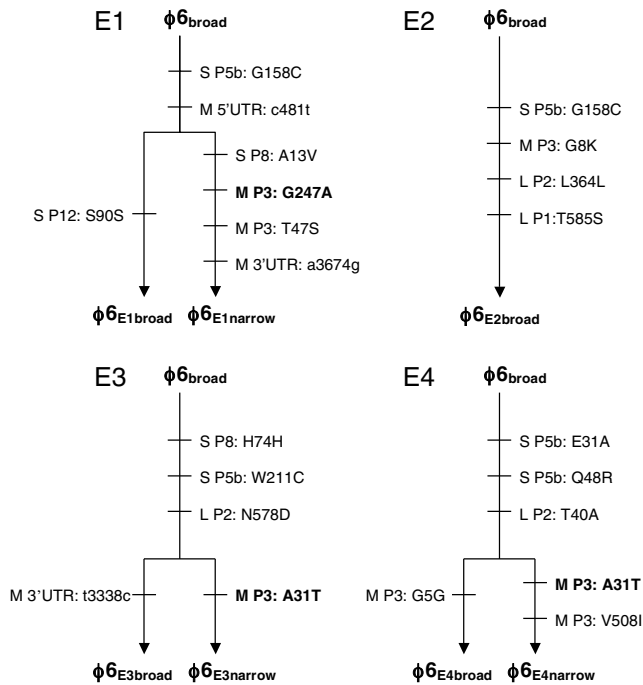

Figure 2. Mutations acquired before and during the divergence of broad and narrow host-range genotypes. For each of the four populations evolved on *Pseudomonas pseudoalcaligenes* ERA, mutations are given with the genome segment and protein-coding gene, if any, in which they are located. Mutations in bold confer a narrow host range.

segment, but it was discounted as the cause of the change in host range because none of the 3' noncoding regions in $\phi 6$ are known to impact function (Mindich 2006). To narrow our focus, we first isolated a narrow host-range genotype, $\phi 6_{E1narrow(day20)}$, from the evolved population at day 20, when the narrow host-range phenotype was starting to sweep through the population (Fig. 1). Sequencing only the regions corresponding to the non-synonymous mutations acquired by the $\phi 6_{E1narrow}$ lineage, we determined that $\phi 6_{E1narrow(day20)}$ differed from $\phi 6_{E1broad}$ by two of the three mutations: A13V in P8 and G247A in P3. Because these mutations existed on different genome segments, we used classic genetic crosses between $\phi 6_{E1narrow(day20)}$ and $\phi 6_{E1broad}$ to generate genomes that contained these individual mutations, but were otherwise isogenic to $\phi 6_{E1broad}$. In this manner, we confirmed that the P3:G247A mutation was the cause of the narrow host-range phenotype. Addition of this mutation to the $\phi 6_{E1broad}$ genome recapitulated the narrow host-range phenotype of $\phi 6_{E1narrow}$, whereas addition of the P8:A13V mutation did not (Table 1).

To confirm that host adaptation and host specificity had a shared genetic basis in our experiments, we determined whether the mutations responsible for the narrow host-range phenotypes also conferred a fitness advantage to the evolving populations. We measured the fitness effect of individual mutations that narrowed

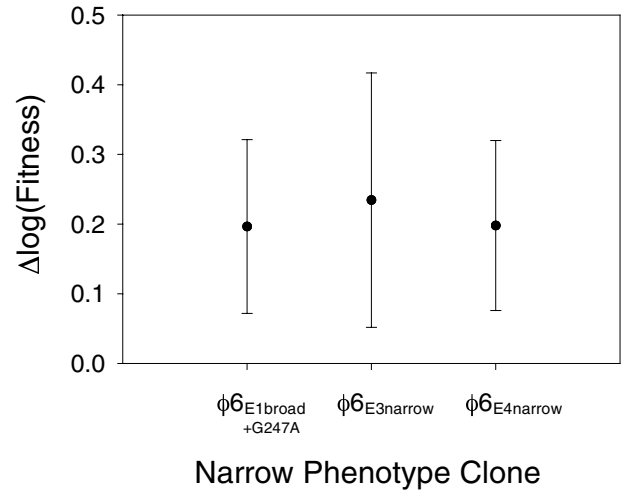

Figure 3. Mutations responsible for narrowing host range confer a fitness advantage on the novel host *Pseudomonas pseudoalcaligenes* ERA. Fitness was measured as growth rate over 24 h (relative to a common competitor), and log-transformed prior to analysis. Data are means and 95% confidence intervals for the selective advantage of narrow host-range phenotypes relative to the appropriate progenitor phage lacking the mutation. The performance advantage of P3: G247A mutation, responsible for the narrow host range in population E1, was determined from a competition with $\phi 6_{E1broad}$. The performance advantage of P3: A31T in the E3 and E4 populations was determined from competitions between $\phi 6_{E3narrow}$, $\phi 6_{E3broad}$, $\phi 6_{E4narrow}$, $\phi 6_{E4broad}$, and the common competitor phage ECC.

host range, using paired growth assays under culture conditions identical to the selection experiment on novel host *P. pseudoalcaligenes*. For each population, we measured the fitness of a genome with the mutation ($\phi 6_{E1broad} + P3:G247A$, $\phi 6_{E3narrow}$, or $\phi 6_{E4narrow}$) relative to the appropriate broad host-range genome without the mutation ($\phi 6_{E1broad}$, $\phi 6_{E3broad}$, or $\phi 6_{E4broad}$). Both mutations in P3 (A31T and G247A) were tested against otherwise isogenic competitors, and both significantly improved fitness, that is, growth rate, on the novel host *P. pseudoalcaligenes* (Fig. 3). Thus, in all three populations showing reduced host range (increased host specificity), the phenomenon was caused indirectly by a single mutation that conferred a selective advantage on the novel host *P. pseudoalcaligenes* (increased host performance).

Discussion

Our laboratory experiment with RNA phage $\phi 6$ shows reproductive isolation can evolve via natural selection. By investigating the process of speciation in laboratory populations of a genetic model system we addressed the role of natural selection in speciation in ways that have not been possible in natural populations, nor in ecological model systems (e.g., stickleback fish [Vines and Schluter 2006], apple maggot flies [Filchak et al. 2000], walking

stick insects [Nosil et al. 2006]). We confirmed that in $\phi 6$ assortative mating (host range) and ecological adaptation (performance on the novel host) had a shared genetic basis. But this result was not due to reproductive incompatibilities that fixed in a population via drift or through genetic hitchhiking. Rather, our results showed that assortative mating evolved via a biologically simple “no-gene” mechanism in which assortative mating arises as a pleiotropic effect of mutations that produce ecological adaptation. In addition, we demonstrated that the action of natural selection can produce reproductive isolation over a short time period, causing incipient viral speciation in $\phi 6$.

Our study demonstrates the power for microbial evolution experiments to bridge the study of microevolution (change within a species) and macroevolution (change from one species into another). The same microevolutionary processes of mutation and natural selection, which led to the adaptation of $\phi 6$ populations to a novel host also resulted in a macroevolutionary event: the evolution of a new virus species that is reproductively isolated from the ancestral phage $\phi 6_{wt}$.

Although we are not the first to use microbes to investigate speciation (Friesen et al. 2004; MacLean 2005; Rozen et al. 2005), we recognize that our unique success in achieving reproductive isolation in the laboratory likely resulted from our unorthodox choice of an RNA virus as a model for studying speciation. However, only two characteristics of the $\phi 6$ system were critical to our success—the short generation time and the high mutation rate. Other characteristics of the $\phi 6$ system (e.g., viruses mate in the habitat where they eat) make our results highly relevant to speciation processes in a variety of organisms that share these characteristics (e.g., walking sticks, apple maggot flies, and sticklebacks). However, the pleiotropy between improved performance in a new habitat and increasing specificity has rarely been as clearly observed as it was in our study (e.g., trait associations can also be explained by linkage disequilibrium [Via and Hawthorne 2002]). We attribute our success to the ability to completely dissect the genetic basis of adaptation and to measure fitness instead of fitness components.

GENETICS OF VIRUS HOST SHIFTS

We observed an identical nucleotide substitution, A31T, in the P3 attachment gene of $\phi 6_{E3narrow}$ and $\phi 6_{E4narrow}$. Evidence strongly suggested that this single molecular change was solely responsible for the similarly narrowed host range experienced by these two independently evolving lineages. Thus, the result demonstrates the repeatability of adaptive evolution when phage $\phi 6$ undergoes selection while shifting from its original host onto the novel host *P. pseudoalcaligenes*, as well as the shared consequence of this improved performance for the unselected trait, host breadth. This parallel evolution, where multiple lineages “find” common mutational solutions, is predicted to occur in experimental and natural

populations when there are small numbers of beneficial mutations available (Orr 2005). Such observations are not uncommon in microbial evolution studies conducted under these population-genetics conditions (e.g., Bull et al. 1997). Interestingly, our study showed that beneficial mutations other than A31T could lead to improved performance on the novel host, but that these changes either did not affect host range (in the case of population E2) or narrowed it even more dramatically (in lineage E1).

We designed our laboratory experiments in a manner that mimicked the process of host shifts occurring in nature. It is generally believed that viruses can progressively evolve by first infecting only a reservoir host, then infecting both a reservoir and novel host, and finally infecting only the novel host (e.g., Kuiken et al. 2006). Consistent with this idea, laboratory experiments suggest that viruses shift hosts by experiencing an intermediate broad-host-range genotype, rather than instantaneously shifting from one host range to another, nonoverlapping host range. Thus, the vast majority of identified host-range mutations are shown to expand the host breadth of a virus, instead of causing an immediate host-shift (e.g., Zarling et al. 1977; Aytay and Schulze 1991). Extensive evidence from animal, plant, and bacterial viruses shows that these broad host-range viruses readily lose host range when allowed to adapt to a single host (e.g., reviewed in Fenner and Cairns 1959; Reddy and Black 1974; Marchette et al. 1990; Wichman et al. 1999; Crill et al. 2000; Ebert 2000). Therefore, our laboratory results showing two reproductively isolated phages ($\phi 6_{wt}$ and $\phi 6_{E1narrow}$) bridged by a broad host-range intermediate ($\phi 6_{broad}$) encompass this complete progression. For this reason, our study may reflect how host shifts lead to reproductive isolation in natural virus populations.

Beyond uniquely demonstrating the evolution of reproductive isolation in the laboratory, our study extends the literature describing the evolutionary genetics of narrowed host range when viruses adapt to a single host. Such experiments suggest a causal relationship between the observed reductions in host range and the general role of host attachment proteins in virus adaptation to new hosts, both in the laboratory (e.g., phage $\phi X174$ [Crill et al. 2000], Vesicular Stomatitis Virus [Zárate and Novella 2004], and SARS Coronavirus [Poon et al. 2005]) and in nature (e.g., Influenza Virus [Parrish and Kawaoka 2005], and Canine Parvovirus [Shackelton et al. 2005]). Because many viruses seem capable of changing host range via only one or two mutations (Baranowski et al. 2001; Rainey et al. 2003; Parrish and Kawaoka 2005; Duffy et al. 2006), it hints that other RNA viruses have the potential to evolve reproductive isolation through no-gene mechanisms as rapidly as we observed in $\phi 6$.

GENE FLOW AND VIRAL EMERGENCE

The choice to conduct adaptation experiments in the absence of gene flow from the ancestral population (i.e., in allopatry) likely

facilitated the evolution of reproductive isolation in our experiments. However, because reproductive isolation evolved via a no-gene mechanism in which recombination cannot separate ecological adaptation from assortative mating, we would not expect to obtain a different outcome in the face of gene flow (i.e., in sympatry). In other words, our finding of reproductive isolation via a no-gene mechanism suggests that viral populations could evolve reproductive isolation regardless of whether they were evolving in allopatry or sympatry. In reality, natural virus populations probably often evolve in parapatry. For example, a virus that enters a human host may persist and replicate in that host for tens, hundreds, or perhaps even thousands of generations before it is transmitted to the next human or nonhuman host (Fu 2001; Drummond et al. 2003; Wilson 2004). Although parapatry may facilitate the evolution of viral host races, as in phytophagous insects (Feder et al. 1998; Hawthorne and Via 2001), parapatry would nonetheless provide substantial opportunity for gene flow to influence the divergence of RNA virus populations.

On the one hand, gene flow between the ancestral and emerging virus populations is expected to increase the adaptive genetic variation available to the emerging lineage (Morgan et al. 2005). For instance, gene flow may allow antigenic recombination between ancestral and emerging viruses, aiding the emerging virus' ability to elude the novel host's immune defenses (Hay et al. 2001; Garcia-Arenal and McDonald 2003). In this scenario, the evolution of reproductive isolation would eliminate a source of beneficial genetic variation for the emerging population. We suspect this consequence of reproductive isolation would not have a major impact on RNA virus disease emergence because the high mutation rate of RNA viruses (Drake 1993) ensures that genetic variation is rarely a limiting factor in adaptation.

On the other hand, gene flow between the ancestral and emerging populations may slow adaptation of the emerging lineage to the novel host, if the process occurs often and continually reintroduces alleles that are deleterious for growth on the new host (Lively 1999; Cuevas et al. 2003; Kawecki and Ebert 2004). In this case, reproductive isolation that separates the gene pools of ancestral and emerging populations may hasten adaptation of the emerging virus to the novel host. Because the constant immigration of alleles that are maladapted to the novel host is not something that a high mutation rate can easily counter, the strongest consequence of reproductive isolation for emerging RNA viruses may be to stop gene flow from decreasing the rate of adaptation to the novel host. The rapid pace with which reproductive isolation evolved in our experiments suggests that gene flow is unlikely to slow the adaptation of emerging RNA viruses for very long.

ACKNOWLEDGMENTS

We gratefully acknowledge discussions with M. Ferris and members of the Burch and Turner lab groups. We thank J. Bull, M. Doebeli, M. Noor,

M. Servedio, and an anonymous reviewer for improving earlier versions of this manuscript. SD was a predoctoral fellow of the Howard Hughes Medical Institute. This research was supported by National Science Foundation grant DEB-0408000 to PET and SD, National Science Foundation grant DEB-0452163 and a Yale Center for Genomics and Proteomics Pilot Grant to PET, and National Institutes of Health grant GM067940 to CLB.

LITERATURE CITED

- Aytay, S., and I. T. Schulze. 1991. Single amino acid substitutions in the hemagglutinin can alter the host range and receptor binding properties of H1 strains of Influenza A virus. *J. Virol.* 65:3022–3028.
- Baranowski, E., C. M. Ruiz-Jarabo, and E. Domingo. 2001. Evolution of cell recognition by viruses. *Science*. 292:1102–1105.
- Bennett, A. F., K. M. Dao, and R. E. Lenski. 1990. Rapid evolution in response to high-temperature selection. *Nature*. 346:79–81.
- Bull, J. J., M. R. Badgett, H. A. Wichman, J. P. Huelsenbeck, D. M. Hillis, A. Gulati, C. Ho, and I. J. Molineux. 1997. Exceptional convergent evolution in a virus. *Genetics* 147:1497–1507.
- Burch, C. L., and L. Chao. 2000. Evolvability of an RNA virus is determined by its mutational neighborhood. *Nature*. 406:625–628.
- Chao, L., T. Tran, and C. Matthews. 1992. Muller's ratchet and the advantages of sex in the RNA virus $\phi 6$. *Evolution*. 46:289–299.
- Coyne, J. A., and H. A. Orr. 2004. *Speciation*. Sinauer Associates, Sunderland, MA.
- Crill, W. D., H. A. Wichmann, and J. J. Bull. 2000. Evolutionary reversals during viral adaptation to alternating hosts. *Genetics*. 154:27–37.
- Cuevas, J. M., A. Moya, and S. F. Elena. 2003. Evolution of RNA virus in spatially structured heterogeneous environments. *J. Evol. Biol.* 16:456–466.
- Darwin, C. 1859. *On the origin of species by means of natural selection, or the preservation of favoured races in the struggle for life*. John Murray, London.
- Delbrück, M., and W. T. Bailey Jr. 1946. Induced mutations in bacterial viruses. *Cold Spring Harb. Symp. Quant. Biol.* 11:33–37.
- Dobzhansky, T. 1937. *Genetics and the origin of species*. Columbia Univ. Press, New York.
- Doebeli, M., U. Dieckmann, J. A. J. Metz, and D. Tautz. 2005. What we have also learned: adaptive speciation is theoretically possible. *Evolution*. 59:691–695.
- Drake, J. W. 1993. Rates of spontaneous mutation among RNA viruses. *Proc. Natl. Acad. Sci. USA* 90:4171–4175.
- Drummond, A. J., O. G. Pybus, A. Rambaut, R. Forsberg, and A. G. Rodrigo. 2003. Measurably evolving populations. *Trends Ecol. Evol.* 18:481–488.
- Duffy, S., P. E. Turner, and C. L. Burch. 2006. Pleiotropic costs of niche expansion in the RNA bacteriophage $\phi 6$. *Genetics*. 172:1–7.
- Ebert, D. 2000. Experimental evidence for rapid parasite adaptation and its consequences for the evolution of virulence. Pp. 163–184 in R. Poulin, S. Morand, and A. Skorping, eds. *Evolutionary biology of host-parasite relationships: theory meets reality*. Elsevier Science, Amsterdam.
- Feder, J. L., S. H. Berlocher, and S. B. Opp. 1998. Sympatric host-race formation and speciation in *Rhagoletis* (dipetera: terphritidae): a tale of two species for Charles D. Pp. 408–441 in S. Mopper, and S. Strauss, eds. *Genetic structure in natural insect populations: effects of ecology, life history and behavior*. Chapman and Hall, New York.
- Feder, J. L., J. B. Roethele, K. Filchak, J. Niedbalski, and J. Romero-Severson. 2003. Evidence for inversion polymorphism related to sympatric host race formation in the apple maggot fly, *Rhagoletis pomonella*. *Genetics*. 163:939–953.

- Fenner, F., and J. Cairns. 1959. Variation in virulence in relation to adaptation to new hosts. Pp. 225–249 in F. M. Burnet, and W. M. Stanley, eds. *The viruses: biochemical, biological and biophysical properties*. Academic Press, New York.
- Filchak, K. E., J. B. Roethele, and J. L. Feder. 2000. Natural selection and sympatric divergence in the apple maggot *Rhagoletis pomonella*. *Nature* 407:739–742.
- Friesen, M. L., G. Saxer, M. Travisano, and M. Doebeli. 2004. Experimental evidence for sympatric ecological diversification due to frequency-dependent competition in *Escherichia coli*. *Evolution* 58:245–260.
- Fu, Y.-X. 2001. Estimating mutation rate and generation time from longitudinal samples of DNA sequences. *Mol. Biol. Evol.* 18:620–626.
- Garcia-Arenal, F., and B. A. McDonald. 2003. An analysis of the durability of resistance to plant viruses. *Phytopathology* 93:941–952.
- Hawthorne, D. J., and S. Via. 2001. Genetic linkage of ecological specialization and reproductive isolation in pea aphids. *Nature* 412:904–907.
- Hay, A. J., A. Gregory, A. R. Douglas, and Y. P. Lin. 2001. The evolution of human influenza viruses. *Philos. Trans. R. Soc. Lond. B* 356:1861–1870.
- Holmes, E. C. 2004. The phylogeography of human viruses. *Mol. Ecol.* 13:745–756.
- Kawecki, T. J., and D. Ebert. 2004. Conceptual issues in local adaptation. *Ecol. Lett.* 7:1225–1241.
- Kuiken, T., E. C. Holmes, J. McCauley, G. F. Rimmelzwaan, C. S. Williams, and B. T. Grenfell. 2006. Host species barriers to influenza virus infections. *Science* 312:394–397.
- Leu, J.-Y., and A. W. Murray. 2006. Experimental evolution of mating discrimination in budding yeast. *Curr. Biol.* 16:280–286.
- Lively, C. M. 1999. Migration, virulence and the geographic mosaic of adaptation by parasites. *Am. Nat.* 153:S34–S47.
- MacLean, R. C. 2005. Adaptive radiation in microbial microcosms. *J. Evol. Biol.* 18:1376–1386.
- Malmberg, R. L. 1977. The evolution of epistasis and the advantage of recombination in populations of bacteriophage T4. *Genetics* 86:607–621.
- Marchette, N. J., D. R. Dubois, L. K. Larsen, P. L. Summers, E. G. Kraiselburd, D. J. Gubler, and K. H. Eckels. 1990. Preparation of an attenuated dengue 4 (341750 Carib) virus vaccine. I. *Am. J. Trop. Med. Hyg.* 43:212–218.
- Mayr, E. 1942. *Systematics and the origin of species*. Columbia Univ. Press, New York.
- Mindich, L. 2006. Phages with segmented double-stranded RNA genomes. Pp. 197–207 in R. Calendar, and S. T. Abedon, eds. *The bacteriophages*. Oxford Univ. Press, New York.
- Mindich, L., J. F. Sinclair, D. Levine, and J. Cohen. 1976. Genetic studies of temperature-sensitive and nonsense mutants of bacteriophage phi6. *Virology* 75:218–223.
- Morgan, A. D., S. Gandon, and A. Buckling. 2005. The effect of migration on local adaptation in a coevolving host-parasite system. *Nature* 437:253–256.
- Muller, H. J. 1939. Reversibility in evolution considered from the standpoint of genetics. *Biol. Rev. Camb. Phil. Soc.* 14:261–280.
- . 1940. Bearing of the *Drosophila* work on systematics. Pp. 185–268. in J. S. Huxley, ed. *The new systematics*. Clarendon Press, Oxford.
- . 1942. Isolating mechanisms, evolution and temperature. *Biol. Symp.* 6:71–125.
- Nosil, P., C. P. Sandoval, and B. J. Crespi. 2006. The evolution of host preference in allopatric vs. parapatric populations of *Timema cristinae* walking sticks. *J. Evol. Biol.* 19:929–942.
- Orr, H. A. 2005. The probability of parallel evolution. *Evolution* 59:216–220.
- Parrish, C. R., and Y. Kawaoka. 2005. The origins of new pandemic viruses: the acquisition of new host ranges by canine parvovirus and influenza A viruses. *Annu. Rev. Microbiol.* 59:553–586.
- Poon, L. L. M., C. S. W. Leung, K. H., K. Y. Yuen, Y. Guan, and J. S. M. Peiris. 2005. Recurrent mutations associated with isolation and passage of SARS coronavirus in cells from non-human primates. *J. Med. Virol.* 76:435–440.
- Rainey, G. J. A., A. Natanson, L. F. Maxfield, and J. M. Coffin. 2003. Mechanisms of avian retroviral host range extension. *J. Virol.* 77:6709–6719.
- Reddy, D. V. R., and L. M. Black. 1974. Deletion mutations of the genome segments of wound tumor virus. *Virology* 61:458–473.
- Rice, W. R. 1987. Speciation via habitat selection: the evolution of reproductive isolation as a correlated character. *Evol. Ecol.* 1:301–314.
- Rice, W. R., and E. E. Hostert. 1993. Laboratory experiments on speciation: what have we learned in 40 years? *Evolution* 47:1637–1653.
- Rice, W. R., and G. W. Salt. 1990. The evolution of reproductive isolation as a correlated character under sympatric conditions: experimental evidence. *Evolution* 44:1140–1152.
- Rozen, D. E., D. Schneider, and R. E. Lenski. 2005. Long-term experimental evolution in *Escherichia coli*. XIII. phylogenetic history of a balanced polymorphism. *J. Mol. Evol.* 61:171–180.
- Schemske, D. W. 2000. Understanding the origin of species. *Evolution* 54:1069–1073.
- Schluter, D. 2001. Ecology and the origin of species. *Trends Ecol. Evol.* 16:372–380.
- Shackelton, L. A., C. R. Parrish, U. Truyen, and E. C. Holmes. 2005. High rate of viral evolution associated with the emergence of canine parvovirus. *Proc. Natl. Acad. Sci. USA* 102:379–384.
- Templeton, A. R. 1980. The theory of speciation via the founder principle. *Genetics* 94:1011–1038.
- Turner, P. E., and L. Chao. 1998. Sex and the evolution of intrahost competition in RNA virus phi6. *Genetics* 150:523–532.
- Via, S., and D. J. Hawthorne. 2002. The genetic architecture of ecological specialization: correlated gene effects on host use and habitat choice in pea aphids. *Am. Nat.* 159:S76–S88.
- Vines, T. H., and D. Schluter. 2006. Strong assortative mating between allopatric sticklebacks as a by-product of adaptation to different environments. *Proc. R. Soc. Lond. B* 273:911–916.
- Wichman, H. A., M. R. Badgett, L. A. Scott, C. M. Boillianne, and J. J. Bull. 1999. Different trajectories of parallel evolution during viral adaptation. *Science* 285:422–424.
- Wilson, R. A. 2004. Test cases, resolvability and group selection: a critical examination of the myxoma case. *Phil. Sci.* 71:380–401.
- Zárate, S., and I. S. Novella. 2004. Vesicular stomatitis virus evolution during alternation between persistent infection in insect cells and acute infection in mammalian cells is dominated by the persistence phase. *J. Virol.* 78:12236–12242.
- Zarling, D. A., A. G. Mosser, and H. M. Temin. 1977. Spontaneous mutations affecting the host range of the B77 strain of avian sarcoma virus involve type-specific changes in the virion envelope antigen. *J. Virol.* 21:105–112.

Associate Editor: J. Koella