

Sarcomere Lengthening and Tension Drop in the Latent Period of Isolated Frog Skeletal Muscle Fibers

P. HAUGEN and O. STEN-KNUDSEN

From the Department of Biophysics, University of Copenhagen, Copenhagen, Denmark

ABSTRACT A laser diffraction technique has been developed for registering small changes in sarcomere length. The technique is capable of resolving changes as small as 0.2 \AA in isolated frog skeletal muscle fibers. The small sarcomere lengthening that accompanies the drop in tension in the latent period of contraction was investigated. We suggest this lengthening be named latency elongation (LE). The LE is present in a completely slack fiber and must, therefore, be caused by a forcible lengthening process. Furthermore, the LE is dependent on the existence of an overlap between thin and thick filaments. The rate of elongation and the time interval between stimulation and maximum elongation may vary along the fiber. The maximum elongation was $3\text{--}5 \text{ \AA}$ per sarcomere. At any instant the drop in tension is a product of the sum of sarcomere lengthenings along the fiber and the slope stiffness of the series elasticity. The latency relaxation (LR) could be registered in the sarcomere length range from $2.2 \text{ }\mu\text{m}$ to $3.6\text{--}3.7 \text{ }\mu\text{m}$. The amplitude went through a sharp maximum at $3.0\text{--}3.1 \text{ }\mu\text{m}$. In the sarcomere length range from 2.2 to $2.8 \text{ }\mu\text{m}$ the delay from onset to maximum LR was nearly proportional to the distance from the Z-line to the overlap zone. A working hypothesis is presented. It is suggested that the LE is caused by a lengthening of the thin filaments.

INTRODUCTION

More than 50 years ago Rauh (1922) demonstrated a minute drop in tension during the last part of the latent period after stimulation of cross-striated muscle. The dependency of the amplitude and time course of this phenomenon on the muscle length was studied extensively on the sartorius muscle by Sandow (1944) who also suggested the term "latency relaxation."

The presence of the latency relaxation in single muscle fibers was first demonstrated by Mauro (1952) and was correlated to the sarcomere length by Guld and Sten-Knudsen (1960). A thorough investigation of the latency relaxation and its dependency on sarcomere length and other characteristics of single fibers was recently reported by Mulieri (1972). In order to get a more accurate recording of the time course of the latency relaxation and thus supplement Mulieri's study, the dependency of latency relaxation on sarcomere length was reinvestigated, using a high resolution tension measuring technique. However, the principal aim of this investigation was to study the sarcomere lengthening that accompanies the tension drop in order to elucidate the relationship between these two

phenomena. Such an investigation would be of value in judging theories for the latency relaxation in a quantitative manner.

Since this sarcomere lengthening has not been demonstrated before, we suggest that it be named "latency elongation" (LE) to distinguish it from its counterpart the latency relaxation (LR). Furthermore, we shall use the terms "tension relaxation" and "sarcomere elongation" for the amplitudes of the latency relaxation and the latency elongation, respectively.

A preliminary report of some of the results has been published (Haugen and Sten-Knudsen, 1975).

METHODS

Preparation

Single twitch muscle fibers were isolated from either the dorsal or the ventral head of the semitendinosus muscle of frogs (*Rana temporaria*). The final dissection was carried out in a Perspex (G. H. Bloore, London) trough with a ground glass bottom. This trough, which was a slightly modified version of the one described by Bartels et al. (1976), was also used as an experimental chamber to avoid transfer of the fiber from one bath to another. The dissection was aided by a stereoscopic microscope (Nikon SMZ-2; Nikon Inc., Instrument Group, Garden City, N. Y.) with a continuously variable magnification ranging from 8 to 40. To avoid irregularities of sarcomere length along the fiber, care was taken to remove as much as possible of the connective tissue. Care was also taken to avoid overstretching the fiber. Surgical silk approximately 40 μm in diameter was tied to the tendons. An additional loop was tied around an insect pin, 0.4 mm in diameter, which, when retracted, left a loop just large enough to be threaded onto the hook of the tension transducer. The microscope could be fitted with a micrometer eyepiece (16 \times ; Carl Zeiss, Inc., New York) to measure fiber diameter. The fiber was rotated so that the smallest and the largest diameters could be measured. The dissection was carried out at room temperature in a Ringer's solution of the following composition (mM): NaCl 116, KCl 2, CaCl₂ 1.8, NaH₂PO₄ 0.9, K₂HPO₄ 0.2, pH 7.2, with the addition of tubocurarine chloride 10 $\mu\text{g}/\text{cm}^3$.

Tension Measurements

Latency relaxation was recorded by means of a piezoelectric tension transducer similar to that described by Bartels et al. (1976), but with a piezoelectric ceramic element of $10 \times 1.5 \times 0.7$ mm (Brush Clevite PZT-Multimorph; Brush Clevite Corp., Cleveland, Ohio). The transducer had a compliance of 1.2 nm/ μN and a resonance frequency of just below 2 kHz and was slightly underdamped. When connected to the 100 M Ω input of the transducer preamplifier it had a time constant of about 100 ms. Tension changes of less than 0.1 μN could be measured this way. Isometric twitch and resting tension was recorded by a strain gauge-type transducer described by Bartels et al. (1976) and modified to measure forces in the range of $1-10^4 \mu\text{N}$ ($1 \mu\text{N} \approx 0.1 \text{ mg-wt}$).

Measurement of Sarcomere Length and Sarcomere Length Changes

A monochromatic laser beam of about 1 mm diameter emitted continuously from a helium-neon gas laser (Spectra-Physics 133; output 1 mW at 632.8 nm wavelength; Spectra-Physics, Inc., Laser Products, Mountain View, Calif.) was directed vertically down on the muscle fiber. Because of the periodicity of the structure along the axis of the fiber, the fiber acts as an optical grating with the sarcomere length as the grating constant. Due to the nearly cylindrical shape of the muscle fiber the diffracted light

corresponding to each of the different intensity maxima will spread out from the fiber in a fan-shaped manner. When projected on a screen the light of the first-order diffraction forms a slightly curved pattern. Because of the small angular spread of the diffracted light, the width of this pattern corresponds very nearly to the width of the incident light beam. At a distance of 90 mm from the fiber a 50 mm long central portion of this pattern could be considered as practically linear. We will refer to this light segment as the diffraction line. The angle, ϕ , between the meridional directions corresponding to the zeroth and the first-order intensity maxima is related to the sarcomere length, S , by

$$S = \lambda/\sin\phi, \quad (1)$$

where λ is the wavelength (632.8 nm). The angle, ϕ , and the changes of angle, $\Delta\phi$, due to small changes in sarcomere length, ΔS , were measured by means of the optical system (6) shown in Fig. 1. This system was suspended so that it could be rotated about a horizontal axis which intersected, at right angles, both the axis of the laser beam (1) and that of the muscle fiber (2), which was placed horizontally. The essential part of the optical system was a 50 mm long, 8 mm wide 90° wedge-shaped mirror (custom made by Micro Optics A/S, Copenhagen) which acted as a beam-splitter located 90 mm from the fiber and oriented perpendicularly to the meridian of the diffracted light. In order to minimize loss of information the beam-splitting edge was very sharp ($\sim 1 \mu\text{m}$). When the edge was located in the beam of the diffraction line the light was divided into two parts each of which was sent towards either of two low noise photodiodes (PIN-040A United Detector Technology, Inc., Santa Monica, Calif.). In front of each diode (9) an aspheric double lens system

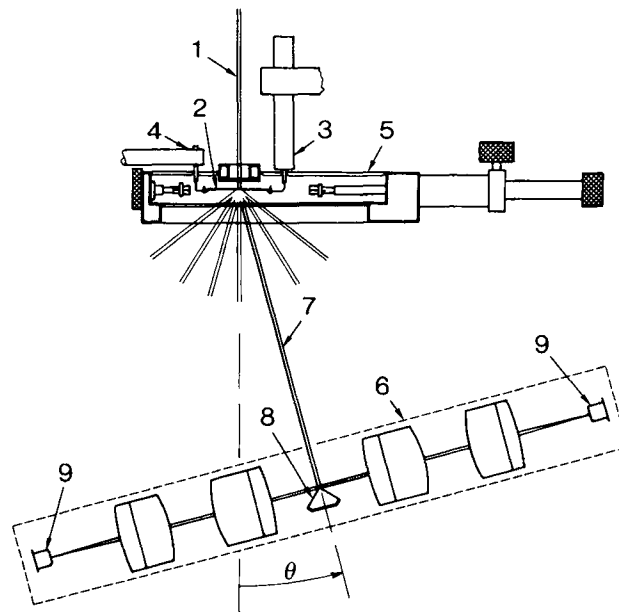

FIGURE 1. Diagram of the experimental setup for measuring tension and sarcomere length changes. The laser beam (1) shines vertically down on the muscle fiber (2) which is suspended between two transducers. One (3) is for registering the LR, the other (4) is to register isometric twitch and resting tension. The muscle is kept in a chamber (5) filled with frog Ringer's. In the optical system (6) the beam of the first-order diffraction line (7) is split by the wedge-shaped mirror (8) and focused upon each of the two photodiodes (9).

was adjusted so that the image of the fiber illuminated by the laser beam was focused upon the diode. The angle, θ , of rotation of the edge of the mirror from the incident beam was measured by means of a differential transformer. The mirror was sufficiently wide so that the first-order diffraction line segment could be fully contained in either of its halves, but not so wide that interference from the zeroth or the second-order diffraction lines occurred. Thus the difference, V_{A-B} , of the diode signals would be zero when the edge of the mirror split the spectral line segment in two halves of equal fluxes ($\phi = \theta$). V_{A-B} would be positive when $\phi > \theta$ and negative when $\phi < \theta$. When the fiber was kept under isometric conditions and the optical system was rotated so that the edge of the beam splitting mirror was passed through the rays of the diffraction line, the resulting diode voltage difference signal, V_{A-B} , as a function of the rotational angle, θ , appeared as a sigmoid as illustrated in Fig. 2, solid curve. This sigmoid is the integral of the light intensity profile of the diffracted beam with respect to θ . The intensity profile is obtained when the sigmoid is differentiated with respect to θ , Fig. 2, dotted curve. An almost identical profile could be obtained by passing the edge of the mirror through the incident beam. It should be pointed out that the angular range, $\Delta\theta$, of about 0.7° which contains the intensity profile represents the width of the diffracted light beam and not the angular spread of the diffracted light which is so small that it only causes second-order effects in this setup. For small perturbations in sarcomere length, ΔS , there was a linear relationship between change in angle, $\Delta\theta$, and change in difference signal

$$\Delta V_{A-B} = k \cdot \Delta\phi = -k \cdot \tan\phi \cdot \Delta S/S \mid_{\theta = \text{const.}} \quad (2)$$

The same change in signal could be brought about by changing the angle of the optical system by a small amount $\Delta\theta$

$$\Delta V_{A-B} = -k \cdot \Delta\theta \mid_{\theta = \text{const.}} \quad (3)$$

The constant k , which could be determined from Eq. 3 by rotating the optical system so that the edge of the mirror was passed through the beam of the diffraction line, was used as a calibration constant in Eq. 2. In order to test the reliability of this calibration procedure, a fiber was stretched passively by means of a displacement transducer made from a loudspeaker coil. The sarcomere lengthening was estimated from the relation: $\Delta S = S \cdot \Delta l/l$ where l and Δl are muscle length and length change, respectively. An example of this is shown in Fig. 3. The resulting diode difference signal did only differ by a few percent from the one estimated for the same sarcomere length change from the calibration curve, V_{A-B} vs. θ . In the experiments the calibration curve, V_{A-B} vs. θ , was used to estimate the sarcomere length changes.

Inaccuracies due to irregular shapes of the intensity profile were minimized by selecting the geometrically most regular areas of the fiber for sarcomere length change measurements. In order to compensate for changes in the diffraction line intensity, the difference signal was divided by the sum signal by means of a fast analog divider. This does not compensate for changes in the width of the diffraction line, however, this should not introduce any appreciable error since the change in the angular spread of the diffraction band from rest to tetanus is reported to be less than a few percent by Kawai and Kuntz (1973).

A control experiment was performed in order to determine whether the lateral part of the diffraction line changed by the same angle $\Delta\phi$ as the medial part during the latent period. The diffraction line movement was recorded in three different situations: (A) with full aperture, (B) with a narrow slit open over the middle of the mirror, and (C) with a narrow slit open over the lateral part of the mirror. In each case the amplitude of the difference signal during the latency elongation was proportional to the slope of the corresponding V_{A-B} vs. θ characteristic. Thus the estimated change in angle $\Delta\phi$, and

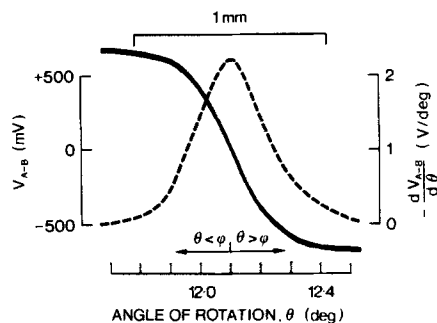

FIGURE 2

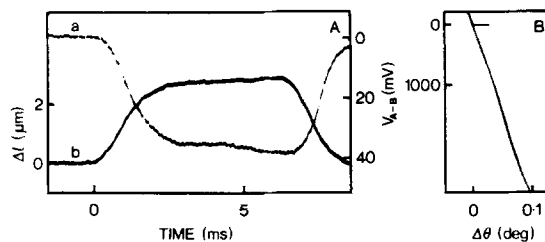

FIGURE 3

FIGURE 2. The solid curve is to illustrate the sigmoidal shape of the V_{A-B} vs. θ characteristic as obtained when the beam-splitting mirror was passed through the entire width of the first-order diffraction line. The fiber was held at a sarcomere length of $3.02 \mu\text{m}$. The broken curve is to illustrate the shape of the intensity profile which was obtained by differentiating the sigmoid. Horizontal bar indicates a 1 mm translation of the beam-splitting mirror. The illuminated portion of the fiber is about 0.7 mm.

FIGURE 3. Illustration and comparison of the two calibration procedures. (A) Simultaneous recording of a sudden length change (trace *b*) and the corresponding change in the difference signal ΔV_{A-B} from the photodiodes (trace *a*) from a single fiber 25.25 mm long when the sarcomere length is $2.95 \mu\text{m}$. $\Delta S/\Delta V_{A-B} = 0.092 \text{ \AA}/\text{mV}$. (A small amount of 50 Hz hum is seen in trace *a*.) (B) The difference signal from the two photodiodes when the edge of the wedge-shaped mirror is passed through the first-order diffraction line. Ordinate, output in millivolts; abscissa, angle of rotation. Same fibers as in A at same degree of stretch. This calibration procedure yields a $\Delta S/\Delta V_{A-B} = 0.088 \text{ \AA}/\text{mV}$ which differs from the value obtained in A by less than 5%. Method B was used throughout the experiments.

hence the estimated sarcomere elongation, was not affected by the recording situation. This excludes the possibility of any appreciable misinterpretation due to lateral movement of light along the slightly curved diffraction line leading to a change in the differential signal. Our straight line approximation of the diffraction line segment is thus justified.

Mounting of the Fiber

The muscle chamber together with its auxiliary equipment (LR- and isometric twitch transducers and the displacement transducer) was mounted on a board which could be moved horizontally in the longitudinal and the transverse direction of the fiber by two micrometer screws. Thus the entire fiber could be scanned by the laser beam. Alignment and length adjustment of the fiber was achieved by means of a Prior (W. R. Prior & Co. Ltd., Herts., U.K.) micromanipulator which carried the LR transducer. The two tendons of the fiber were attached by means of the preformed silk loops to the LR transducer and, according to requirements, to the isometric twitch transducer or to the displacement transducer.

Stimulation

To ensure maximum synchronicity of activation of the sarcomeres, the muscle fiber was stimulated along its entire length by a homogeneous transverse field. This field was formed by two rectangular platinized platinum electrodes connected to the floating

output of the stimulation amplifier. The stimulus was given as a super threshold (10–20 V/cm) diphasic pulse of 1 ms total duration.

Noise

The main sources of noise in the tension as well as in the sarcomere length change measurements were mechanical vibrations in the room and direct acoustical coupling. To minimize this interference the vibration-sensitive parts of the setup were placed in a wooden box (80 × 80 × 80 cm) lined with polyethylene foam. The box rested upon a heavy iron plate suspended by springs and tennis balls on a heavy iron shelf bolted to the wall of the building. In spite of these efforts the experiments could only be performed at times when the traffic noise was at a reasonably low level. Under these precautions sarcomere length changes down to about 0.2 Å and tension changes down to about 0.1 μN could be detected. In both cases the limiting factor was electrical noise.

Recording Apparatus

The signals from twitch and LR transducers as well as sarcomere length change signal from the optical system were all filtered by low-pass filters with 6 dB per octave roll-off and –3 dB point at 2 kHz. In this way high frequency noise was reduced without affecting the signal. In order to compensate for timelag (<0.1 ms) in the recording of LR due to the frequency characteristic of the LR transducer, the signal from the optical system was filtered by a critically damped 12 dB per octave low-pass filter with a resonance frequency of 2 kHz. This signal was AC coupled with a time constant of 100 ms. The signals were photographically recorded with an Auto Camera (MK. 3; Shackman & Sons, London) from a Tektronix 5440 oscilloscope (Tektronix, Inc., Beaverton, Ore.) equipped with a 5B12 dual time base and two 5A48 dual trace amplifiers. Since signals that exceeded the height of the screen of the oscilloscope would cause intolerable crosstalk and distortion to the other traces, the signals had to be passed through unit gain limiters which could be adjusted so that the traces did not exceed the upper or lower division lines with more than half a division on the screen. The V_{A-B} vs. θ characteristic as shown in Fig. 2 B was likewise photographed from a Tektronix 564B storage oscilloscope with a voltage analogue to θ obtained from the differential transformer as X-axis input.

Experimental Procedure

Two types of experiments were generally performed.

SIMULTANEOUS RECORDINGS OF LR, ISOMETRIC TWITCH TENSION, AND RESTING TENSION The fiber was suspended between the LR transducer and the isometric twitch transducer. The fiber length was adjusted to give a sarcomere length of about 3 μm and the fiber was stimulated for adjustment of optimal gain of the LR trace. The fiber was then shortened until it just became slack. This normally happened at a sarcomere length of 2.2–2.3 μm. To obtain a resting tension at this sarcomere length the fiber was stimulated, whereafter the actual recordings could take place. After each stimulation the fiber was stretched in steps of 0.25–0.5 mm and allowed to rest for about 2 min before the next stimulation. The sarcomere length (S) was computed from the angle ϕ between the zeroth and the first-order diffraction lines which was measured at regular intervals. Since the illuminated portion of the fiber is about 0.7 mm (see Fig. 2) the sarcomere lengths thus computed represent an average of 200–300 sarcomeres. A relation between the amount of stretch and estimated average sarcomere length, $\langle S \rangle$, was determined by linear regression. The values of $\langle S \rangle$ were used to relate isometric twitch tension, resting tension, and LR to sarcomere length.

SIMULTANEOUS RECORDINGS OF LATENCY RELAXATION AND SARCOMERE LENGTH CHANGES The fiber was now suspended between the displacement transducer and the LR transducer. The general procedure was similar to the one described above, but events at lower sarcomere lengths than $2.3 \mu\text{m}$ were also studied. The fiber was stimulated and sarcomere length change recorded at several places along the fiber. In relating LE of one sarcomere group to sarcomere length, the actual measured value for that group (S) was used. In some experiments only LR was recorded. These were performed as described in the preceding paragraph. All experiments were carried out at room temperature, 18–23°C.

RESULTS

Simultaneous Recordings of Twitch and Latency Relaxation

In six fibers isometric twitch and latency relaxation were recorded simultaneously. An example of such a recording is shown in Fig. 4.

ISOMETRIC TWITCH TENSION AND SARCOMERE LENGTH Some fibers showed an approximately linear decrease of twitch tension with increasing sarcomere lengths in the range from 2.3 to $3.7 \mu\text{m}$, extrapolating to zero at about $3.7 \mu\text{m}$. In Fig. 5 A the twitch tension recordings from such a fiber are shown, and in Fig. 6 the amplitudes are related to sarcomere length. In other fibers the twitch tension decreased with sarcomere length only in the range from 2.8 to about 3.7 – $3.8 \mu\text{m}$, whereas it remained substantially constant or even increased with sarcomere length in the range from 2.3 to 2.7 – $2.8 \mu\text{m}$ resembling the findings of Close (1972) obtained from a whole sartorius muscle. These fibers showed a tendency that the twitch extrapolated to zero for sarcomere lengths larger than $3.7 \mu\text{m}$.

TENSION RELAXATION AND SARCOMERE LENGTH An example of a set of 10 recordings from one experiment is shown in Fig. 5. The recordings of the twitches obtained at various sarcomere lengths are shown superimposed in Fig. 5 A and those of the corresponding latency relaxations are shown in Fig. 5 B and

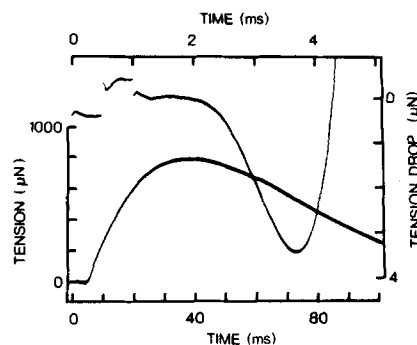

FIGURE 4. Simultaneous recording of isometric twitch tension (lower trace, with the abscissa in milliseconds below and the ordinate in micronewtons to the left), and latency relaxation (upper trace, with the abscissa in milliseconds above and the ordinate in micronewtons to the right). The stimulation waveform is added to both traces. $\langle S \rangle = 3.02 \mu\text{m}$.

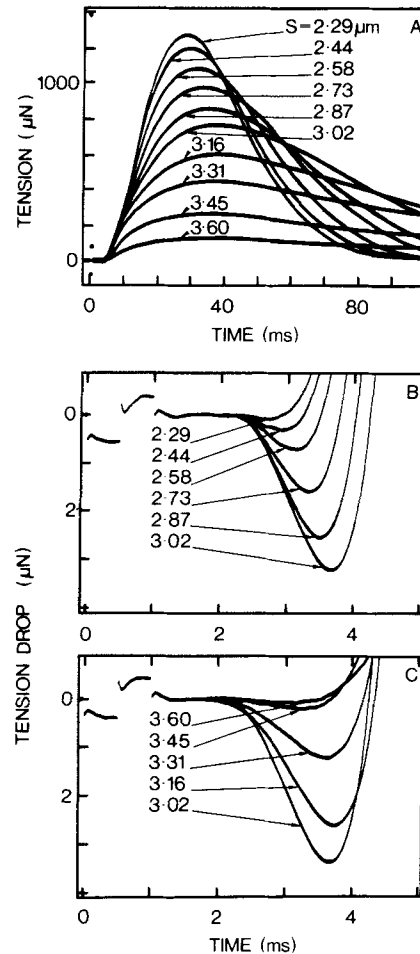

FIGURE 5. To illustrate the influence of the sarcomere length on the time course of the isometric twitches (A) and the latency relaxation (B and C). The figure was made by superposition of simultaneous records at 10 different sarcomere lengths. (S in micrometers indicated at each trace.) Note the difference in scale between A and B and C. The stimulation waveform is added to the traces. Same fiber as in Fig. 4.

C. The amplitude of the latency relaxation, the tension relaxation, increases with stretch up to a sarcomere length of about $3 \mu\text{m}$ (Fig. 5 B) and then decreases upon stretch beyond this value (Fig. 5 C). In the latter case there is also a marked reduction in the rate of tension drop. The time (t_1) from stimulation to the onset of the tension drop is substantially uninfluenced by the sarcomere length while the times of maximum tension drop (t_2) are strongly dependent on sarcomere length. The dependency of the tension relaxation on the sarcomere length is more clearly demonstrated in Fig. 6 where all the tension relaxation measurements from the experiment of Fig. 5 are plotted vs. sarcomere length.

In all the fibers examined a sharp maximum in the tension relaxation was

found. The sarcomere length at which the maximum occurred did, however, vary within the range of 3.0–3.1 μm . This can be seen in Fig. 7 where the tension relaxations in five fibers were plotted in percent of the maximum value for each fiber.

Although the relative tension relaxation did not vary appreciably from one fiber to the other in the sarcomere length range from 2.3 to 3.0 μm , the variation was considerable beyond 3 μm sarcomere length. In most of the fibers examined the tension relaxation extrapolated to zero at 3.5–3.7 μm sarcomere length which is within the range of overlap between the thin and the thick filaments. In some fibers the tension relaxation extrapolated to zero at sarcomere lengths beyond 3.6–3.7 μm . However, the latency relaxation was never seen unless followed by a twitch.

TIME COURSE OF THE LATENCY RELAXATION AND SARCOMERE LENGTH The time course of the latency relaxation was investigated in 10 fibers. The delay, t_1 , of the onset of the tension drop showed no dependence on the sarcomere length in either of the fibers. When the fiber was almost slack or heavily stretched it was difficult to measure this delay with any great accuracy since the rate of tension drop was small. The time, t_2 , to maximum tension drop and the time, t_3 , to the recrossing of the resting tension level were both measurable to an accuracy

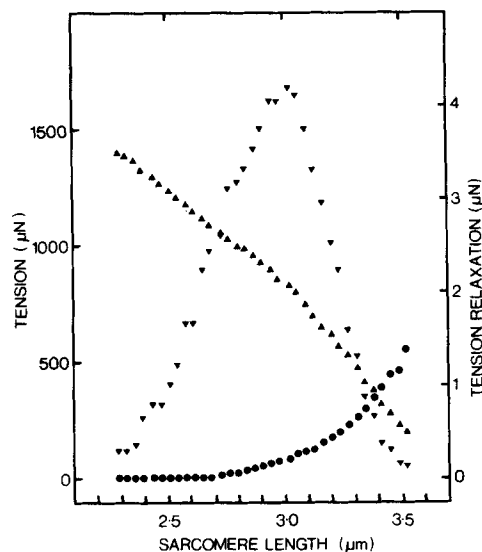

FIGURE 6

FIGURE 6. Isometric twitch tension (\blacktriangle) resting tension (\bullet) and tension relaxation (\blacktriangledown) as a function of sarcomere length. Left ordinate, twitch and resting tension (micronewtons); right ordinate, tension relaxation (micronewtons); abscissa, sarcomere length (micrometers). Same fiber as in Figs. 4 and 5.

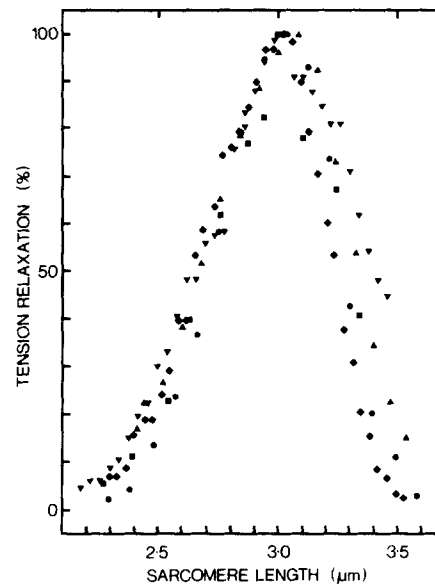

FIGURE 7

FIGURE 7. Dependency of tension relaxation on sarcomere length in five fibers. Ordinate, tension relaxation in percent of the maximum value for each fiber; abscissa, sarcomere length (micrometer).

within 0.1–0.05 ms. Both showed a near linear relation to sarcomere length in the range of 2.2 to 2.6–2.7 μm . In this range the resting tension was below the level of detection (less than $\sim 5 \mu\text{N}$). Beyond 2.7 μm sarcomere length, the values of t_2 and t_3 increased at a progressively lesser rate and might even pass through a maximum. This departure from linearity coincides with the progressive increase in resting tension. This behavior is illustrated in Fig. 8 which is obtained from the same fiber as Figs. 4–6.

Linear regression analysis was made in the sarcomere length ranges of reliable measurements of t_1 and in the linear regions of t_2 and t_3 (thick lines), and the regression lines were drawn (thin lines). The regression lines intersected at a sarcomere length of about 1.5 μm (± 1 SD indicated by bar). This value is close to the length of the thick filament (Gordon et al., 1966; H. E. Huxley, 1972). Thus there seems to be a near proportionality between the time from onset to maximum tension drop or to the recrossing of the resting tension level and the distance from the Z-line region to the zone of overlap between thin and thick filaments.

Sarcomere Length Change

Latency relaxation and the corresponding sarcomere lengthening, the latency elongation, were recorded simultaneously in eight fibers.

SARCOMERE LENGTH VARIATIONS For any given degree of stretch of the

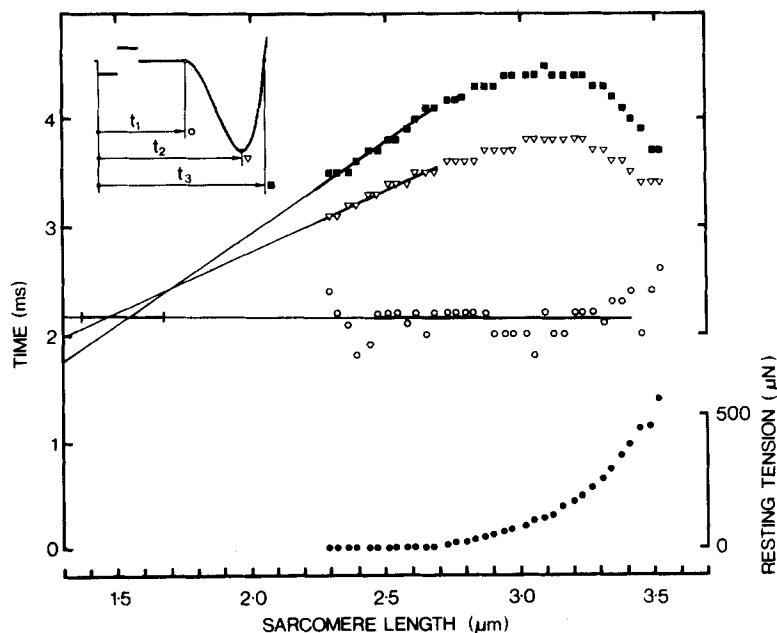

FIGURE 8. To illustrate the influence of the sarcomere length on the time of onset of LR, t_1 (open circles), the time to maximum tension drop, t_2 (triangles), and the time to development of positive twitch tension, t_3 (filled squares), as indicated in the insert diagram. For further details see text. The resting tension is indicated by filled circles.

resting fiber there was a certain nonuniformity of sarcomere lengths along the fiber (Fig. 9). In addition the sarcomeres at the fiber ends tended to be shorter than average. This tendency was most pronounced for heavily stretched fibers as also described by A. F. Huxley and Peachey (1961).

LATENCY ELONGATIONS Fig. 10 shows nine simultaneous recordings of latency relaxation and sarcomere length changes obtained from different positions along one fiber. The records were chosen to illustrate the types of responses which were encountered when different portions along the length of the fiber were examined. It appears from the figure that the sarcomere lengthening was not uniform along the fiber. While the onset of the latency elongation usually coincided with the onset of the latency relaxation, maximum elongation either coincided with the maximum tension drop (Fig. 10 A) or occurred before (Fig. 10 B,D) or after (Fig. 10 C). However, more complex types of responses were also observed. Thus in Fig. 10 E the contraction starts without any previous elongation. In Fig. 10 F there is an initial shortening much like a mirror image of the falling phase of the latency relaxation before the onset of a latency elongation similar to those in Figs. 10 A-D, but occurring later. In Figs. 10 G and H there is an onset of the latency elongation similar to those of Figs. 10 A-C. However, when the tension development recrosses the resting level there is a point of inflection in the sarcomere shortening of Fig. 10 G leading to another sarcomere lengthening before the sarcomere contraction takes over. In Fig. 10 H the shortening passes through a maximum where the tension development recrosses the resting level. In Fig. 10 I the onset of the sarcomere lengthening coincides with the onset of the tension drop, but the lengthening proceeds after the maximum tension drop is reached and contraction in the observed part of the fiber does not take over within the recorded time interval.

It appears from Fig. 10 that the time course of the local sarcomere lengthening does not necessarily follow that of the latency relaxation. It seems plausible that there is an interaction between the sarcomeres in such a way that each sarcomere, aside from responding to the events following its own activation, also is influenced by the tension development in the entire fiber. In the remainder of this paper we will limit the use of the term "latency elongation" to the response types of Figs. 10 A-C where the interference from the events occurring in the rest of the fiber only plays a minor role.

SARCOMERE ELONGATION AND SARCOMERE LENGTH While no latency re-

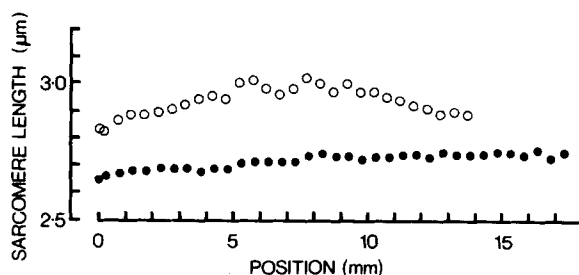

FIGURE 9. Variation of sarcomere lengths along two fibers. Ordinate, sarcomere length (micrometer); abscissa, distance from fiber end (millimeter).

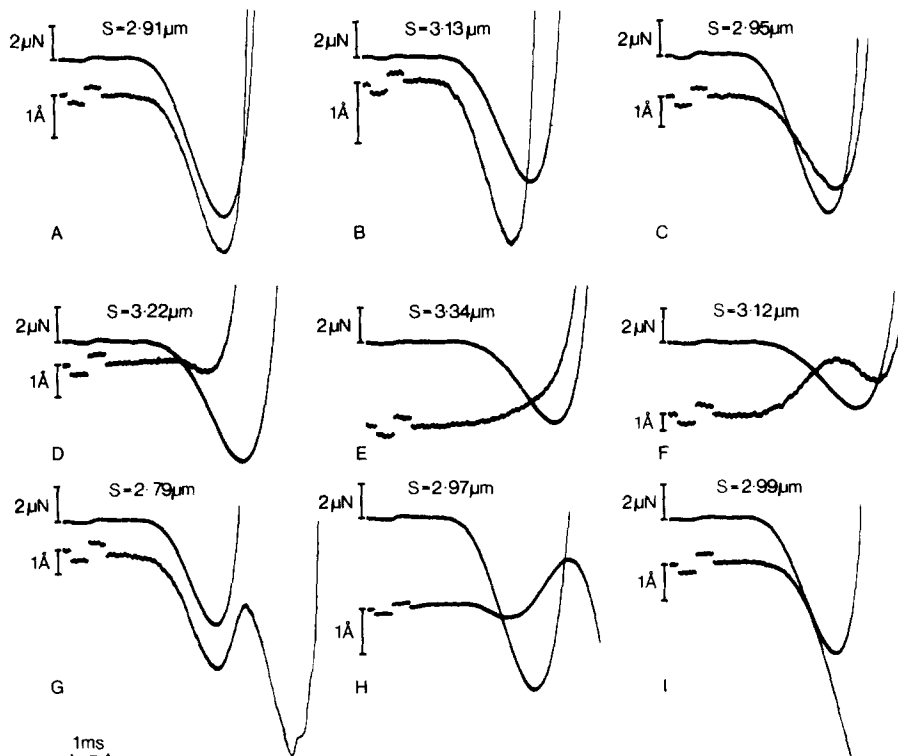

FIGURE 10. Simultaneous recordings of latency relaxation (upper trace) and sarcomere length changes (lower trace; increase in sarcomere length is shown as a downward deflection). The recordings show different types of response obtained along one fiber. Time calibration, 1 ms. Calibration for tension and sarcomere lengthening, $2 \mu\text{N}$ and 1 \AA , respectively. For further details see text.

laxation could be recorded at sarcomere lengths less than $2.15\text{--}2.20 \mu\text{m}$, since the fiber carried no resting tension, a latency elongation, however, could be registered at sarcomere lengths down to $2.05 \mu\text{m}$. An example is shown in Fig. 11. The fiber was passively shortened until it became completely slack and then stimulated. While there was no trace of a latency relaxation, a latency elongation of an amplitude (sarcomere elongation) of about 1 \AA could still be observed.

The relation between sarcomere elongation and sarcomere lengths is shown in Fig. 12. The data points represent 148 measurements from eight fibers. Only responses of type A and B of Fig. 10 were used. The data were collected into 14 groups, each representing a sarcomere length interval. The mean value of the sarcomere elongations was plotted at the mean sarcomere length for the group (filled circles). Thin bars indicate ± 1 SD of sarcomere elongation and sarcomere length, respectively; thick bar ± 1 SEM. For comparison the tension relaxation as a function of sarcomere length from Fig. 6 is indicated by open circles. In the sarcomere length range from 2.3 to $3.0 \mu\text{m}$ the average sarcomere elongation increased about three times while the tension relaxation grew by a factor of about 20.

In heavily stretched fibers the number of sarcomeres where latency elongations were observed was reduced since most sarcomere groups showed response types similar to that of Fig. 10I.

DISCUSSION

The transmission grating properties of striated muscle were first exploited by Ranvier (1874). The development of sensitive photographic emulsions made it possible for Sandow (1936*a,b*) to record the diffraction line movements both during passive stretch and during contraction of frog sartorius muscle. The first diffraction studies on single fibers were made by Buchthal and Knappeis (1940). More recently Cleworth and Edman (1972) have been able to register sarcomere length changes as small as 50 Å in single fibers using a gas laser as the source of monochromatic coherent light, and registering the diffraction line movements photographically. Kawai and Kuntz (1973) used an array of photovoltaic cells as the detector of diffraction line movements and were able to obtain a resolution of sarcomere length changes within 30 Å from small fiber bundles. As mentioned, the present technique faithfully registered small changes in sarcomere length when these resulted from passive length changes of the muscle fiber (Fig. 3A,B). Sarcomere length changes as small as 0.2 Å (average of ~200 sarcomeres) could be detected. The maximum sarcomere length change which could be estimated in the present setup was on the order of ± 200 Å. This range corresponds to the near linear part of the sigmoidal V_{A-B} vs. θ characteristic (Fig. 2).

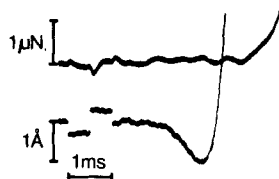

FIGURE 11

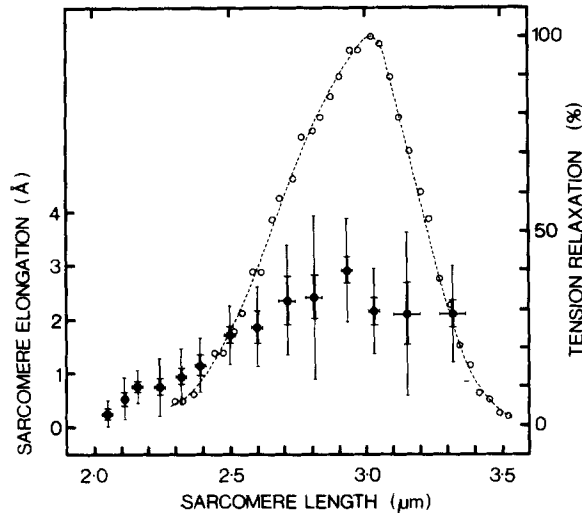

FIGURE 12

FIGURE 11. Tension development (upper trace) and sarcomere length change (lower trace; increase in sarcomere length is shown as a downward deflection) in a completely slack fiber at a sarcomere length of $2.17 \mu\text{m}$. Time calibration, 1 ms. Calibration for tension and sarcomere lengthening, $1 \mu\text{N}$ and 1Å , respectively.

FIGURE 12. Average sarcomere elongation as a function of sarcomere length (filled circles). For details see the text. The tension relaxations of Fig. 6 are indicated by open circles for comparison.

We assume that also when the fiber is stimulated, any change in the diode voltage difference signal, V_{A-B} , is solely due to a change in the sarcomere length. The salient point is the extent to which this assumption is justified: all recordings were performed with the beam-splitting mirror located so that initially V_{A-B} was zero, i.e. the edge of the beam-splitting mirror went through the center of gravity of the diffraction line so that the diffracted light was divided into two parts of equal fluxes. Under this condition the present optical setup is insensitive to changes in the shape of the intensity profile of the diffraction line as long as the position of the center of gravity does not change. Thus random changes in the sarcomere lengths of the different fibrils or of the different sarcomeres would not alter the position of the center of gravity as long as the average sarcomere length is not changed, and the V_{A-B} signal would still be zero. Neither would any signal emerge if the diffraction line underwent an overall reduction of intensity. An emerging V_{A-B} signal would require a shift in the position of the center of gravity relative to the beam-splitting edge. We find it difficult to see how this could occur without a change in the average sarcomere length. When the center of gravity has moved relative to the beam-splitting edge as a result of a change in the average sarcomere length, a simultaneous change in the intensity profile would affect the V_{A-B} signal. In the present study no investigation of possible changes in the intensity profile was undertaken. However, Kawai and Kuntz (1973) recently reported that the changes in the width and the intensity of the diffraction line were small during the latent period and initial part of the contraction. Thus, it should be justified to assume that the inaccuracies of our sarcomere length change measurements are within acceptable tolerances and that the signal V_{A-B} , at least to a first order of approximation, reflects the small sarcomere length changes in the stimulated as well as in the resting muscle fiber.

Recently Mulieri (1972) has published a thorough and systematic investigation of the dependency of the latency relaxation on sarcomere length in single muscle fibers from the frog. Although the principal aim of the present study was to examine whether an elongation of the sarcomeres concomitant to latency relaxation could be detected, some of Mulieri's experiments were repeated since we wanted to measure more accurately the dependency and the time course of the latency relaxation on the sarcomere length.

There is a general agreement between the results of Mulieri (1972) and those in the present study, but also some discrepancies. First, Mulieri reported a plateau of the tension relaxation in the sarcomere length range from 2.83 μm to 3.16 μm . Since the finding of a plateau is in contrast to the works by Sandow (1944), Guld and Sten-Knudsen (1960), and Matsumara (1969), the tension relaxation was scrutinously measured against the sarcomere length at small intervals ($< 0.05 \mu\text{m}$). We found no plateau in any of the fibers studied. Second, Mulieri (1972) reports that tension relaxation extrapolated to zero at a sarcomere length of about 3.8 μm . In most fibers examined, we found that the tension relaxation extrapolated to zero at 3.5–3.7 μm . Some fibers, however, tended to have larger irregularities in the distribution of sarcomere lengths along the fiber than those normally found. This might have been due to excessive stretch during the preparation. In those fibers latency relaxation often was found at regression values of sarcomere length well beyond 3.7 μm . However, the latency

relaxation was always followed by a contraction, as also reported by Matsumara (1969). Thus, in some areas of the fibers there must have been sarcomeres with an overlap between thick and thin filaments. That these sarcomeres indeed were the ones to generate the tension drop is substantiated by our failure to register any latency elongation at sarcomere lengths greater than 3.4–3.5 μm .

A striking observation was the occurrence of a latency elongation in completely slack fibers. Since the fiber in this condition does not carry any resting tension, the sarcomere lengthening cannot be explained solely by a change in compliance of some structure. Therefore, some other processes must be responsible for the observed sarcomere lengthening. It is likely that these processes also are responsible for at least part of the tension drop observed when the fiber is carrying a resting tension. Our observation of latency elongation in slack fibers supports the idea of Sandow (1947) "that during the latency relaxation, some forcible lengthening change occurs in the contractile substance."

In a more recent theory proposed by Sandow (1966) and extended by Mulieri (1972), the assumption is made that part of the resting tension is carried by the sarcoplasmic reticulum, and that on release of calcium from the terminal cisternae the sarcoplasmic reticulum would lose some of its ability to carry tension, which then would lead to a drop in resting tension. Although it is conceivable that the processes described in the Sandow-Mulieri hypothesis might lead to an increase in the compliance of the sarcoplasmic reticulum, it is difficult to see how these processes could produce a longitudinal expanding force. Furthermore, the Sandow-Mulieri hypothesis does not explain why the latency relaxation disappears when there is no overlap between thin and thick filaments. An increase in the osmotic pressure of the sarcoplasm as suggested by Peachey (1968) might possibly give a longitudinal expanding force, but without making additional assumptions it is also difficult to see how the dependency on overlap would arise.

On this basis we will assume that the generation of the latency elongation and hence the latency relaxation is due to some process taking place in the filamentary structure upon activation. Hill (1968) suggested that part of the resting tension, the filamentary resting tension (FRT), was carried by already established cross-bridges. He proposed that the latency relaxation could be due to a reduction of the FRT. Such a mechanism, however, does not seem to be able to give the forcible lengthening as demonstrated in slack fibers. The constant-volume behavior of the filamentary lattice could be thought to give a sarcomere lengthening in response to the filaments moving nearer together, either as a result of a reduced electrostatic repulsion between the filaments (H. E. Huxley and Brown, 1967), or as a result of the establishment of cross-bridges (D. R. Wilkie, private communication). While it is doubtful whether the forcible lengthening could be explained by H. E. Huxley's hypothesis, Wilkie's proposal could explain this aspect. One problem arises when the cross-bridges are assumed to be the generators of the latency relaxation: the underlying process would have to start when the calcium ions diffuse from the terminal cisternae into the region occupied by the involved structures. If these structures are in the zone of overlap between the thick and the thin filament, the time lag caused by this diffusion would be dependent on sarcomere length. To account for the

apparent independence of the time (t_1) to onset of the tension drop from sarcomere length, the calcium diffusion would have to be very fast. However, in that case it is difficult to see how the strong dependency of the time (t_2), to maximum tension drop on sarcomere length should arise without assuming some very complicated processes. Also the thick filament lengthening which was demonstrated by Haselgrove (1975) would be less probable to cause the latency elongation for the same reasons as discussed above. It seems likely that an increased radial tension as that proposed by Wilkie would lead to a volume decrease rather than a volume increase. However, Abbott and Baskin (1962) found a minute increase in the volume at the time of the latency relaxation. This increase in volume may be explained if the underlying process is a longitudinal expansive force.

Without being able to outrule other possibilities, we feel that the most simple explanation for the sarcomere lengthening and thus for the tension drop is a minute lengthening of the thin filament. Such a lengthening might well be a consequence of the conformational change taking place in the filament during the activation (Vibert et al., 1972; Haselgrove, 1973; H. E. Huxley, 1973). The activation occurs as Ca^{2+} is bound to the troponin molecules (Ebashi and Endo, 1968), and thus the proposed lengthening would proceed along with the diffusion of calcium from the Z-line region to the overlap zone (Winegrad, 1970). Then t_1 would indicate the release of calcium from the terminal cisternae, and t_2 the instant where the rate of lengthening is equaled by the growing rate of contraction upon the diffusion of calcium into the overlap zone. This gives a simple explanation for the near proportionality between $t_2 - t_1$ and the distance from the Z-line to the overlap zone, and for the almost equal rate of tension drop for moderately stretched fibers.

A. F. Huxley (1957) suggested that a thin filament lengthening might be mediated by a proposed set of S-filaments joining the thin filaments across the H-band. Such filaments, however, have not been found, and if they were to exist, it would be difficult to see why the latency relaxation should depend on overlap. Hill (1968) has described a short-range elastic component (SREC) which he suggested was due to the existence of cross-bridges attached even in the resting muscle. Our assumption then is that rather than being mediated by the S-filaments as proposed by A. F. Huxley, the thin filament lengthening would be mediated by the elasticity of the attached cross-bridges. To account for the existence of latency elongation in slack fibers the cross-bridges must be able to withstand a small compressive force. The sarcomere elongation would be counteracted by the slope stiffnesses of the parallel elastic component and the parts of the series elastic component originating from the tendons and the suspension. Both increase progressively with stretch, and could be the cause of the reduced rate of tension drop seen in fibers stretched beyond $3 \mu\text{m}$ sarcomere length, and thus to a reduced rate of increase of t_2 with stretch as seen in Figs. 5 and 8.

From the present hypothesis one might expect some interaction between the sarcomeres. Aside from responding to the events following its own activation, each sarcomere must give an elastic response to the overall tension changes in the fiber. Variations in the resting level of calcium or other factors might influence the number of attached cross-bridges along the fiber. A decreased number of

attached cross-bridges would reduce the sarcomere lengthening response to the filament lengthening and increase the compliance to the all-over tension changes. The response types of Fig. 10 D-I may be due to this. Such variations would influence the rate of sarcomere lengthening and might be the cause of the variations in the time of maximum lengthening as in Fig. 10 A-C. Variations in the attachment of new cross-bridges may lead to responses like those in Fig. 10 G-I where the sarcomeres observed appeared to be stretched out by the developing twitch tension. Variations in the geometry of the transverse tubules or in the sarcoplasmic reticulum along the fiber may influence the time course of activation of each sarcomere and may lead to responses like the one in Fig. 10 F. However, such complex responses may also be explained in terms of variations in cross-bridge establishment as described above.

Sandow et al. (1974) recently reported that D₂O induced an increase in t_1 and decreased the rate of tension drop, but did not alter the tension relaxation. This was taken as support for the Sandow-Mulieri hypothesis, however, the findings may as well be interpreted in terms of the present theory.

The tension drop of the latency relaxation is at any instant an expression for the average response by being a product of the sum of sarcomere lengthenings along the fiber and the slope stiffness in the series elastic component and viscous damping effects. In the strongly extended fiber (3.1-3.3 μm) sarcomere lengthening responses like those in Fig. 10 E-I were increasingly frequent with stretch, and fewer sarcomeres were found to display typical latency elongations. This might be one reason for the dramatic fall in the tension relaxation in this range.

The assumption that cross-bridges are attached and give rise to an elastic coupling between the thick and the thin filaments plays a crucial role in our hypothesis. The assumption is clearly supported by results from recent experiments correlating the SREC to sarcomere length (Haugen and Sten-Knudsen, 1976*a*) and from studies on skinned fibers (Moss et al., 1976). Furthermore, preliminary results (Haugen and Sten-Knudsen, 1976*b*) indicate a correlation between the tension relaxation and the number of attached cross-bridges which may be reduced for a very short period by rapid stretch of the fiber. These findings are consistent with the present hypothesis.

The authors wish to acknowledge their indebtedness to B. Deublein and S. Lohmann for skillful machining of the experimental setup, to H. Nissen-Petersen and B. Andersen for assistance in the construction and building of the electronics, and to Jette Jensen and Julia Ann Halkier for aid in preparing the manuscript.

The work was supported by grant C.18.17-7 from the Norwegian Research Council for Science and the Humanities to Dr. Haugen.

Received for publication 3 October 1975.

REFERENCES

- ABBOTT, B. C., and R. J. BASKIN. 1962. Volume changes in frog muscle during contraction. *J. Physiol. (Lond.)* **161**:379-391.
- BARTELS, E. M., P. JENSEN, and O. STEN-KNUDSEN. 1976. The dependence of tension relaxation in skeletal muscle on the number of sarcomeres in series. *Acta Physiol. Scand.* In press.

- BUCHTHAL, F., and G. G. KNAPPEIS. 1940. Diffraction spectra and minute structure of the cross-striated muscle fibre. *Skand. Arch. Physiol.* **83**:281-307.
- CLEWORTH, D. R., and K. A. P. EDMAN. 1972. Changes in sarcomere length during isometric tension development in frog skeletal muscle. *J. Physiol. (Lond.)*. **227**:1-17.
- CLOSE, R. I. 1972. The relation between sarcomere length and characteristics of isometric twitch contractions of frog sartorius muscle. *J. Physiol. (Lond.)*. **220**:745-762.
- EBASHI, S., and M. ENDO. 1968. Calcium ion and muscle contraction. *Prog. Biophys. Mol. Biol.* **18**:123-183.
- GORDON, A. M., A. F. HUXLEY, and F. J. JULIAN. 1966. The variation in isometric tension with sarcomere length in vertebrate muscle fibres. *J. Physiol. (Lond.)*. **184**:170-192.
- GULD, C., and O. STEN-KNUDSEN. 1960. Correlation of isometric twitch tension and latency relaxation to sarcomere length in frog muscle fibres. *Acta Physiol. Scand.* **50**(Suppl. 175):63-65.
- HASELGROVE, J. C. 1973. X-ray evidence for a conformational change in the actin-containing filaments of vertebrate striated muscle. *Cold Spring Harbor Symp. Quant. Biol.* **37**:341-352.
- HASELGROVE, J. C. 1975. X-ray evidence for conformational changes in the myosin filaments of vertebrate striated muscle. *J. Mol. Biol.* **92**:113-143.
- HAUGEN, P., and O. STEN-KNUDSEN. 1975. Early mechanical response in isolated frog skeletal muscle fibres. *Acta Physiol. Scand.* **95**:6A.
- HAUGEN, P., and O. STEN-KNUDSEN. 1976a. On the attachment of cross-bridges in resting isolated frog striated muscle fibre. *Acta Physiol. Scand.* **96**:18A.
- HAUGEN, P., and O. STEN-KNUDSEN. 1976b. Dependence of the latency relaxation on cross-bridge attachment in isolated frog skeletal muscle fibres. *Acta Physiol. Scand.* **440**(Suppl.):94.
- HILL, D. K. 1968. Tension due to interaction between the sliding filaments in resting striated muscle. The effect of stimulation. *J. Physiol.* **199**:637-684.
- HUXLEY, A. F. 1957. Muscle structure and theories of contraction. *Prog. Biophys. Biophys. Chem.* **7**:255-318.
- HUXLEY, A. F., and L. D. PEACHEY. 1961. The maximum length for contraction in vertebrate striated muscle. *J. Physiol.* **156**:150-165.
- HUXLEY, H. E. 1972. Molecular basis of contraction in cross-striated muscle. In *The Structure and Function of Muscle*. Bourne, editor. Academic Press, Inc., New York. **1**:301-387.
- HUXLEY, H. E. 1973. Structural changes in the actin- and myosin-containing filaments during contraction. *Cold Spring Harbor Symp. Quant. Biol.* **37**:361-376.
- HUXLEY, H. E., and W. BROWN. 1967. The low-angle X-ray diagram of vertebrate striated muscle and its behaviour during contraction and rigor. *J. Mol. Biol.* **30**:383-434.
- KAWAI, M., and I. D. KUNTZ. 1973. Optical diffraction studies of muscle fibres. *Biophys. J.* **13**:857-876.
- MATSUMARA, M. 1969. On the nature of the latency relaxation of frog skeletal muscle. *Jpn. J. Physiol.* **19**:701-711.
- MAURO, A. 1952. Latency relaxation in the single striated muscle fiber. *Acta Physiol. Scand.* **25**(Suppl. 89):59.
- MOSS, R. L., M. R. SOLLINS, and F. J. JULIAN. 1976. Calcium activation produces a characteristic response to stretch in both skeletal and cardiac muscle. *Nature (Lond.)*. **260**:619-621.

- MULIERI, L. A. 1972. The dependence of the latency relaxation on sarcomere length and other characteristics of isolated muscle fibres. *J. Physiol.* **223**:333-354.
- PEACHEY, L. D. 1968. Muscle. *Annu. Rev. Physiol.* **30**:401-440.
- RAUH, F. 1922. Die Latenzzeit des Muskelementes. *Z. Biol.* **76**:25-48.
- RANVIER, L. 1874. Du spectre produit par les muscle striés. *Arch. Physiol.* **6**:775. (Quoted by Sandow 1936*a,b*).
- SANDOW, A. 1936*a*. Diffraction patterns of the frog sartorius and sarcomere behaviour under stretch. *J. Cell. Comp. Physiol.* **9**:37-54.
- SANDOW, A. 1936*b*. Diffraction patterns of the frog sartorius and sarcomere behaviour during contraction. *J. Cell. Comp. Physiol.* **9**:55-75.
- SANDOW, A. 1944. Studies on the latent period of muscle contraction. Method. General properties of latency relaxation. *J. Cell. Comp. Physiol.* **24**:221-256.
- SANDOW, A. 1947. Latency relaxation and a theory of muscular mechano-chemical coupling. *Ann. N. Y. Acad. Sci.* **47**:895-929.
- SANDOW, A. 1966. Latency relaxation: a brief analytical review. *MCVQ Med. Coll. Va. Q.* **2**:82-89.
- SANDOW, A., E. C. SPHIGAS, and M. K. D. PAGALA. 1974. D₂O-induced alterations of latency relaxation of frog muscle. *Fed. Proc.* **33**:383.
- VIBERT, P. J., J. C. HASELGROVE, J. LOWY, F. R. POULSEN. 1972. Structural changes in actin-containing filament of muscle. *Nat. New Biol.* **236**:182-183.
- WINEGRAD, S. 1970. The intracellular site of calcium activation of contraction in frog skeletal muscle. *J. Gen. Physiol.* **55**:77-88.