



Since January 2020 Elsevier has created a COVID-19 resource centre with free information in English and Mandarin on the novel coronavirus COVID-19. The COVID-19 resource centre is hosted on Elsevier Connect, the company's public news and information website.

Elsevier hereby grants permission to make all its COVID-19-related research that is available on the COVID-19 resource centre - including this research content - immediately available in PubMed Central and other publicly funded repositories, such as the WHO COVID database with rights for unrestricted research re-use and analyses in any form or by any means with acknowledgement of the original source. These permissions are granted for free by Elsevier for as long as the COVID-19 resource centre remains active.



ELSEVIER

Middle East respiratory syndrome and severe acute respiratory syndrome

Rahul Vijay¹ and Stanley Perlman^{1,2}

The recent emergence of the Middle East respiratory syndrome (MERS)-CoV, a close relative of the Severe Acute respiratory syndrome (SARS)-CoV, both of which caused a lethal respiratory infection in humans, reinforces the need for further understanding of coronavirus pathogenesis and the host immune response. These viruses have evolved diverse strategies to evade and block host immune responses, facilitating infection and transmission. Pathogenesis following infection with these viruses is characterized by a marked delay in the induction of Type I interferon (IFN I) and, subsequently, by a poor adaptive immune response. Therapies that expedite IFN I induction as well as interventions that antagonize immunoevasive virus proteins are thus promising candidates for immune modulation.

Addresses

¹ Interdisciplinary Program in Immunology, University of Iowa, Iowa City, IA 52242, United States

² Department of Microbiology, University of Iowa, Iowa City, IA 52242, United States

Corresponding author: Perlman, Stanley (Stanley-perlman@uiowa.edu)

Current Opinion in Virology 2016, 16:70–76

This review comes from a themed issue on **Viral immunology**

Edited by **Liisa K Selin** and **Allan J Zajac**

For a complete overview see the [Issue](#) and the [Editorial](#)

Available online 12th February 2016

<http://dx.doi.org/10.1016/j.coviro.2016.01.011>

1879-6257/© 2016 Elsevier B.V. All rights reserved.

Introduction

While most CoVs cause the common cold in humans, infection with two recently emerged CoVs, SARS-CoV and MERS-CoV, resulted in more severe pulmonary disease with alarmingly high case fatality rates [1]. SARS-CoV first emerged in Guangdong province of China in the winter of 2002 [2]. With a high rate of nosocomial transmission to healthcare professionals combined with a lack of precedence for a CoV outbreak, SARS-CoV spread across 29 countries infecting more than 8000 humans and resulting in a staggering 774 deaths (~10%) [3]. MERS-CoV was first reported in Saudi Arabia a decade later in June 2012 [4**]. Cases were also detected in other parts of the Middle East including Jordan, Qatar, Oman and the United Arab Emirates. Virus was spread by travelers from the Arabian peninsula to Europe, Africa

and other regions of Asia including, most recently, the Republic of Korea, infecting a total of 1626 people, with a case fatality rate of 36.0%, as of January 11, 2015 [5,6**,7**,8]. Both of these outbreaks were notably characterized by an age-dependent increase in morbidity and mortality. Thus, during the SARS epidemic no patients under the age of 24 years died, while mortality was more than 50% in those over 65 years of age [9]. Similarly, MERS also has a similar age-dependent pattern with elderly patients showing signs of more severe disease. MERS tends to be most severe in patients with co-morbidities such as diabetes, chronic pulmonary disease and renal disease [10]. While no more SARS cases were reported since 2004, new MERS cases continue to appear. The respiratory route of transmission of MERS-CoV combined with the geographical location of its persistence makes MERS a serious public health threat that if not curtailed, has the potential to develop as a major epidemic in the years to come. Although no MERS cases have been associated with the Hajj and Umrah pilgrimages, such large gatherings make this a potentially major problem [1]. In spite of the efforts by researchers across the globe, no effective drug treatments or vaccines have been formulated to control SARS or MERS. In this review we summarize the similarities and differences between SARS and MERS-CoV with an emphasis on the key features of the host immune response and tactics used by the viruses to evade the immune response.

Virology and transmission

Coronaviruses are enveloped RNA viruses that fall under the Nidovirus superfamily (Figures 1 and 2). With a positive-sense single-stranded RNA genome of 31 kb, coronaviruses contain the largest RNA genome identified to date [11]. Both SARS and MERS-CoVs are betacoronaviruses, belonging to lineages b and c respectively. They share similar genomic structures with multiple open reading frames (ORFs). While the genes required for viral RNA replication are located on the 5'-terminal two thirds of the genome, those that encode the structural proteins are located on the 3' end [11]. Other genes, which encode accessory proteins not required for virus replication and viability, are distributed throughout the structural genes. MERS-CoV has five different accessory proteins while SARS-CoV has eight of them (Figure 1) [12**]. Some of these genes including some of the non-structural proteins encoded at the 5' end of the genome are involved in induction and modulation of innate immune responses in the host (humans).

Figure 1

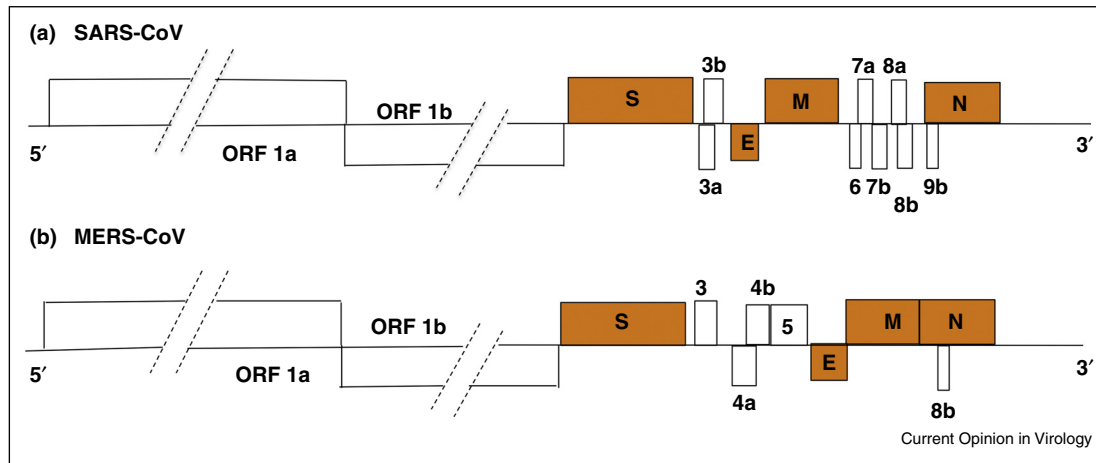

Genome organization of CoVs. Organization of genes and ORFs in the genome of SARS-CoV (a) and MERS-CoV (b) is illustrated. The 5' 2/3 of the genome is comprised ORF1a and ORF1b, which code for various non-structural proteins, many of which are involved in virus replication [11]. The 3' 1/3 of the genome encodes for structural proteins: spike (S), envelope (E), matrix (M) and nucleocapsid (N). Interspersed between these structural proteins are accessory proteins: SARS-CoV has 8 accessory proteins and MERS-CoV has 5. These include SARS-CoV ORF 6 and MERS-CoV ORF 4a and ORF 4b, with well-described roles in immune evasion. Not drawn to scale.

The initiation of infection by CoVs begins with entry into host cells. Being close relatives in the phylogenetic tree, it may not be surprising that both SARS-CoV and MERS-CoV utilize large ectopeptidases on the surface of the host

cell to gain entry; SARS-CoV binds to angiotensin converting enzyme 2 (ACE-2) and MERS-CoV attaches to dipeptidyl peptidase 4 (DPP4) [13,14]. While it has been shown that the spike (S) glycoprotein of SARS-CoV underwent extensive mutation in the region that binds to ACE2 [15], facilitating species to species transmission, the glycoprotein of MERS-CoV has not undergone substantial change in the DPP4-binding region during passage in humans [16,17]. The absence of any mutation in DPP4-binding region suggests that receptor binding is not the rate-limiting step in virus transmission and human adaptation. After binding to their respective receptors, proteolytic cleavage of the S protein results in virus-cell fusion and release of genomic RNA into the cytosol of the host cell. Following the release of RNA, the virus undergoes transcription and replication on rearranged host membranes, including double-membrane vesicles (DMVs) [18]. Newly synthesized RNA is encapsidated within the nucleocapsid protein and then buds into vesicles derived from the endoplasmic reticulum-golgi intermediate compartment (ERGIC) for further assembly into new virions. These vesicles are eventually transported to the cell surface to be released outside the cell.

Figure 2

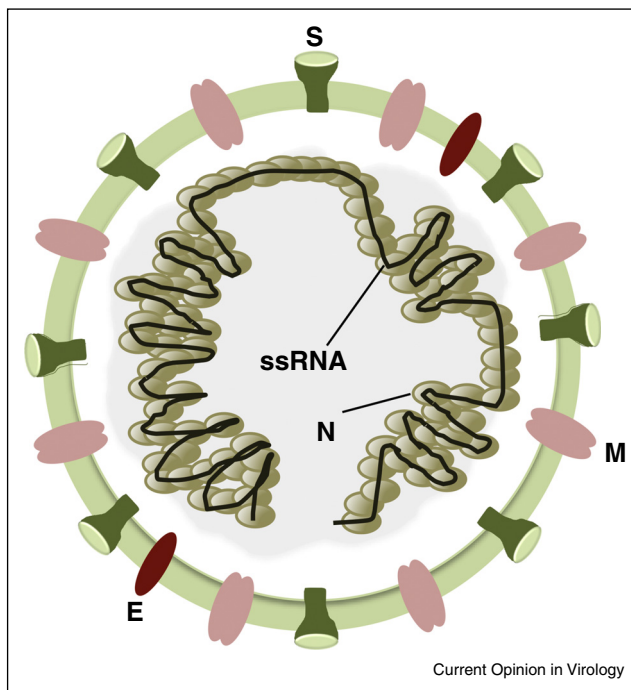

Structure of CoV virion. Schematic representation of the structure of the CoV virion is shown, with structural proteins S, M, E and N marked.

Seroprevalence studies strongly support the notion that camels are one, if not the only, reservoir of MERS-CoV [17,19,20,21,22,23]. Transmission from camels to humans is likely, although not all MERS patients have a history of direct camel exposure [24]. This could mean that other means of indirect transmission like consumption of camel milk or meat or transfer from an intermediate host to humans contribute to spread [20].

Immune response to coronaviruses

All successful viruses have devised strategies to evade immune recognition by the host. These include mechanisms that are both active and passive. Common strategies are to delay the induction of the IFN response, block IFN signaling or counter the action of downstream effector molecules. Coronavirus RNA is not recognized in several cell types, partly because double stranded RNA, which is a potent inducer of IFN is shielded from recognition by intracellular helical sensors, such as RIG-I and MDA5, by containment in membranous structures, such as double membrane vesicles (DMVs) during replication [25,26]. Also viral proteins nsp1, nsp3, nsp16, N protein, SARS-CoV ORF6 and ORF3b and MERS-CoV 4a and 4b inhibit IFN induction or signaling (Figure 3). Nsp1 inhibits IFN signaling in SARS-CoV infected cells by inhibiting phosphorylation of STAT1 as well as by promoting host gene mRNA degradation [12^{**}]. Nsp1 also inhibits host gene expression by binding to the 40S

ribosomal subunit and by inactivating the translation activity of the ribosomes. Nsp3 through its papain-like protease (PLP) domain inhibits IFN I production by deubiquitinating IRF3 and prevents its nuclear translocation [27]. PLP physically interacts with TRAF3, TBK1, IKK ϵ , STING and IRF3, and inhibits phosphorylation and dimerization of IRF3 inhibiting IFN expression [28]. Nsp16, by effecting 2'-O methylation, renders viral RNA indistinguishable from host cell RNA [29,30]. N protein inhibits activator protein 1 (AP1) signaling and protein kinase R (PKR) function as well as nuclear factor- κ B (NF κ B) activation [12^{**}]. The ORF6 protein inhibits IFN signaling by binding to karyopherin- α 2, which prevents nuclear translocation of proteins containing classical nuclear import signals, including STAT1, crucial for IFN signaling [31]. MERS-CoV accessory protein ORF4a antagonizes IFN induction through MDA5 by sequestering viral dsRNA and preventing it from binding to MDA5 [32,33,34^{**}]. MERS-CoV also encodes accessory protein

Figure 3

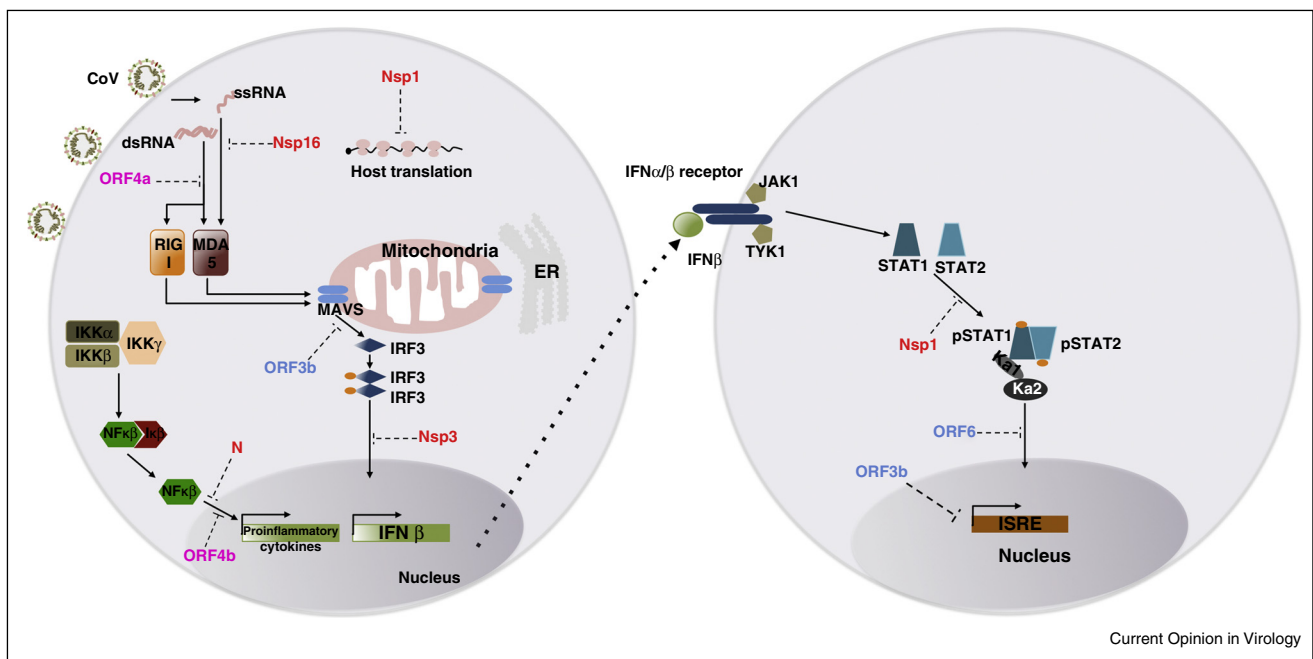

Immune evasion mechanisms of CoVs: schematic representation of IFN I induction by viruses and the mechanism by which CoV evade/block the innate immune response. Initial recognition of double-stranded RNA (dsRNA) (an intermediate during viral replication) is mediated by RIG-I and MDA5 which subsequently signal through mitochondrial protein MAVS. Signaling of MAVS results in activation of various kinases, which phosphorylate IRF3, resulting in its dimerization and trafficking to the nucleus for inducing IFN I production. IFN I thus produced will signal through IFN α/β receptor resulting in its phosphorylation by JAK1 and TYK1. This will result in STAT1/STAT2 complex formation, activation and localization into the nucleus using import factors such as karyopherin α 1 ($K\alpha$ 1) and karyopherin α 2 ($K\alpha$ 2), which will activate various interferon stimulated response elements (ISREs) to bring about an antiviral state. As depicted in the schematic, CoVs have developed strategies to evade/inhibit host innate immune functions, some of which are specific to SARS-CoV [26] (blue) and MERS-CoV (magenta) and some which are shared between the two viruses (red). Nsp1 inhibits phosphorylation of STAT1, promotes host gene mRNA degradation, and also inhibits host mRNA translation. Nsp3 interacts with IRF3, inhibiting its phosphorylation, dimerization and nuclear translocation. Nsp16 renders the virus unrecognizable by cellular sensors MDA5 and RIG-I. N protein inhibits AP1 and NF κ B signaling and PKR function. The ORF6 protein of SARS-CoV binds to $K\alpha$ 2 and prevents nuclear translocation of proteins including STAT1. SARS-CoV ORF3b inhibits IFN induction, possibly downstream from MAVS and IFN signaling. MERS-CoV accessory protein ORF4a sequesters viral dsRNA, preventing it from binding to MDA5. MERS-CoV ORF 4b localizes to the nucleus and inhibits IFN I and NF κ B signaling pathways.

ORF4b, which has been shown to localize to the nucleus and inhibit IFN I synthesis and NF κ B signaling pathways [27].

Further insights into the immune response against MERS-CoV are hindered by the absence of a good animal model that recapitulates the human disease. Mouse DPP4 does not support MERS-CoV replication but mice are susceptible if hDPP4 is supplied exogenously using a replication deficient adeno-virus expressing hDPP4 (Ad5-hDPP4) or if mice are transgenic or 'knocked-in' for hDPP4 [35,36*,37]. Use of Ad5-hDPP4 transduction allows genetically deficient mice to be infected without additional crossing. MERS-CoV infection of transduced Ad5-hDPP4 demonstrated the need for IFN I induction for protection and showed that virus-specific T cells were required for MERS-CoV clearance. Rabbits, macaques and marmosets can also be infected with MERS-CoV although these animals develop few signs of clinical disease (rabbits, macaques) or are difficult to obtain (marmosets) [38–41]. Rabbits and macaques may be useful for study of mild human disease but not for understanding pathogenesis in severely ill patients.

The anti-virus T cell response is critical for virus clearance. The T cell response is initiated by the uptake of viral antigen (Ag) by respiratory dendritic cells (rDC) and rDC migration to draining lymph nodes (DLN), where they prime naïve virus specific T cells. Following priming, naïve T cell undergo activation and clonal proliferation, which then migrate from the DLN to the site of infection (lungs). At this site, they secrete various antiviral chemokines, cytokines and cytotoxic molecules that can directly or indirectly inhibit viral replication. Severely ill MERS and SARS patients exhibited severe leukopenia with marked lymphopenia, impaired activation of T cells and poor anti-virus antibody responses contributing to delayed kinetics of virus clearance [9,42]. In addition, an effective T cell response is required to shut off the initial cytokine response. Thus, severe SARS was also characterized by prolonged cytokine and interferon expression, contributing to a 'cytokine storm' in these patients. Studies of virus-specific CD4 and CD8 T cells in patients recovered from SARS identified several immunogenic epitopes localized to the spike (S) and nucleocapsid (N) proteins [43]. However no information is available yet regarding the T cell epitopes recognized in MERS-CoV-infected patients.

As in many viral infections, development of neutralizing antibodies is required to prevent infection after secondary exposure to the pathogen. The anti-SARS-CoV antibody response appeared to be transient, with antibodies not detected 6 years after infection. In contrast, T cell responses were still detectable [44]. The transient nature of the antibody response raises concerns that SARS recovered patients, if reinfected, would not be protected

from severe disease. Of note, none of these studies examined the mucosal antibody response, which may be very important for protection.

Mouse and macaque models of SARS infection have provided a wealth of knowledge regarding the immune response against CoV in general and SARS-CoV in particular. Human strains of SARS-CoV infect macaques and mice but generally do not cause significant clinical disease [45]. However, upon mouse adaptation, the virus causes severe disease, characterized by a lethal respiratory infection [46]. In some strains, young (6–10 week) mice are completely resistant to disease, remaining without signs of disease even in the absence of Type 1 interferon signaling, while others are highly sensitive [31]. Aged mice of all strains are susceptible to disease, mimicking the age-dependent susceptibility observed in humans. SARS-CoV-infected mice have been useful for identifying host genes important in pathogenesis. Studies with mouse adapted SARS-CoV showed that more severe disease was characterized by inefficient immune activation, such as reduced expression of MHCII, CD86, accompanied by poor CD4 and CD8 T cell responses. Reversing inefficient activation of innate immune cells in mice using TLR ligands such as poly I-C or by depleting inhibitory alveolar macrophages using clodronate liposomes rescued mice from lethal disease [47]. These interventions resulted in enhanced migration of dendritic cells to draining lymph nodes and consequent development of a protective T cell response and enhanced kinetics of virus clearance. Experiments with macaques also showed that aged macaques developed a robust, but dysregulated host innate response against SARS-CoV compared to young animals and this correlated with worse outcomes after infection [48].

Another study showed that age-dependent increases in the levels of a prostaglandin, PGD₂, in the lungs of aged mice inhibited rDC migration to DLN, which in turn impeded virus-specific T cell responses, rendering aged mice susceptible to severe SARS-CoV infection [49*]. Blockade of PGD₂ signaling through its receptor, DP1, resulted in enhanced rDC migration to DLN and virus-specific T cell responses. Given the propensity of MERS-CoV to cause severe disease in aged individuals, it is likely that PGD₂ has a similar role in the context of MERS-CoV infections.

Delayed immune activation was also observed in SARS-CoV-infected human macrophages and dendritic cells, suggesting that the virus is able to evade the immune response. Further SARS-CoV only abortively infects DCs and macrophages [9]. In contrast, MERS-CoV productively infects human macrophages [50]. Notably, MERS-CoV additionally infects activated T cells, which may contribute to disease severity [51]. Similar effects occur in infected airway epithelial cells, the first target cell for

SARS-CoV and MERS-CoV replication. One study compared infection of human epithelial Calu-3 2B4 cells with MERS-CoV and SARS-CoV, highlighting and contrasting the potential antiviral mechanisms mounted by the host against the two viruses. Infection of these cells induced activation of several RNA sensors at approximately the same time post infection. However the IFN response was slightly delayed in cells infected with SARS-CoV compared to MERS-CoV. Additionally, a notable difference was the specific down regulation of the antigen presentation pathway after MERS-CoV infection, which was upregulated after SARS-CoV infection [52]. Thus, although these two viruses are closely related to one another and both elicit delayed immune responses, they induce a significantly different host transcriptional response, suggesting that 'MERS is not SARS'.

Conclusions

The ease with which SARS-CoV and MERS-CoV, as well as other respiratory coronaviruses such as HCoV-OC43 [53,54,16**] crossed species to infect humans make it all the more likely that serious CoV outbreaks will continue to emerge. Fittingly, exactly a decade after SARS, MERS emerged with an even higher mortality rate. Three years after the emergence of MERS, the lack of detailed information about the human disease and of a broadly useful animal model has hindered progress in understanding MERS-CoV disease and immune responses. The recent outbreak in South Korea with over 180 cases emphasizes the importance of instituting proper infection control measures, especially in hospital settings and in developing vaccines and drugs to counter the virus.

Acknowledgement

This work was supported in part by grants from the N.I.H., U.S.A. (RO1 091322, PO1 060699).

References and recommended reading

Papers of particular interest, published within the period of review, have been highlighted as:

- of special interest
- of outstanding interest

1. Zumla A, Hui DS, Perlman S: **Middle East respiratory syndrome.** *Lancet* 2015, **386**:995-1007.
2. Peiris JS, Guan Y, Yuen KY: **Severe acute respiratory syndrome.** *Nat Med* 2004, **10**:S88-S97.
3. Hui DS, Memish ZA, Zumla A: **Severe acute respiratory syndrome vs. the Middle East respiratory syndrome.** *Curr Opin Pulm Med* 2014, **20**:233-241.
4. Zaki AM, van Boheemen S, Bestebroer TM, Osterhaus AD, Fouchier RA: **Isolation of a novel coronavirus from a man with pneumonia in Saudi Arabia.** *N Engl J Med* 2012, **367**:1814-1820. This study reports the discovery, isolation and characterization of HCoV-EMC, which was later renamed MERS-CoV.
5. Feikin DR, Alraddadi B, Qutub M, Shabouni O, Curns A, Oboho IK, Tomczyk SM, Wolff B, Watson JT, Madani TA: **Association of higher MERS-CoV virus load with severe disease and death, Saudi Arabia, 2014.** *Emerg Infect Dis* 2015, **21**:2029-2035.
6. Oboho IK, Tomczyk SM, Al-Asmari AM, Banjar AA, Al-Mugti H, Aloraini MS, Alkhalidi KZ, Almohammadi EL, Alraddadi BM, Gerber SI *et al.*: **2014 MERS-CoV outbreak in Jeddah — a link to health care facilities.** *N Engl J Med* 2015, **372**:846-854. This study describes the reasons for large number of MERS cases in Jeddah.
7. Assiri A, McGeer A, Perl TM, Price CS, Al Rabeeah AA, Cummings DA, Alabdullatif ZN, Assad M, Almulhim A, Makhdoom H *et al.*: **Hospital outbreak of Middle East respiratory syndrome coronavirus.** *N Engl J Med* 2013, **369**:407-416. The first study to describe human-human transmission of MERS in a health care setting.
8. Chen J, Subbarao K: **The immunobiology of SARS.** *Annu Rev Immunol* 2007, **25**:443-472.
9. Memish ZA, Cotten M, Watson SJ, Kellam P, Zumla A, Alhakeem RF, Assiri A, Rabeeah AA, Al-Tawfiq JA: **Community case clusters of Middle East respiratory syndrome coronavirus in Hafr Al-Batin, Kingdom of Saudi Arabia: a descriptive genomic study.** *Int J Infect Dis* 2014, **23**:63-68.
10. Masters PS, Perlman S: **Coronaviridae.** In *Fields Virology*, 1. Edited by Knipe DM, Howley PM. Lippincott Williams & Wilkins; 2013:825-858.
11. Liu DX, Fung TS, Chong KK, Shukla A, Hilgenfeld R: **Accessory proteins of SARS-CoV and other coronaviruses.** *Antiviral Res* 2014, **109**:97-109.
12. Raj VS, Mou H, Smits SL, Dekkers DH, Muller MA, Dijkman R, Muth D, Demmers JA, Zaki A, Fouchier RA *et al.*: **Dipeptidyl peptidase 4 is a functional receptor for the emerging human coronavirus-EMC.** *Nature* 2013, **495**:251-254. This study reports the identification of the functional receptor for MERS-CoV as DPP4.
13. Li W, Moore MJ, Vasilieva N, Sui J, Wong SK, Berne MA, Somasundaran M, Sullivan JL, Luzuriaga K, Greenough TC *et al.*: **Angiotensin-converting enzyme 2 is a functional receptor for the SARS coronavirus.** *Nature* 2003, **426**:450-454.
14. Chinese SMEC: **Molecular evolution of the SARS coronavirus during the course of the SARS epidemic in China.** *Science* 2004, **303**:1666-1669.
15. Cotten M, Watson SJ, Zumla AI, Makhdoom HQ, Palser AL, Ong SH, Al Rabeeah AA, Alhakeem RF, Assiri A, Al-Tawfiq JA *et al.*: **Spread, circulation, and evolution of the Middle East respiratory syndrome coronavirus.** *MBio* 2014, **5**:e01062-13.
16. Sabir JS, Lam TT, Ahmed MM, Li L, Shen Y, Abo-Abba SE, Qureshi MI, Abu-Zeid M, Zhang Y, Khyami MA *et al.*: **Co-circulation of three camel coronavirus species and recombination of MERS-CoVs in Saudi Arabia.** *Science* 2016, **351**:81-84. This study strongly suggests that camels are the major reservoirs for maintenance and diversification, as well the major source of infection in human with MERS-CoV.
17. Knoops K, Kikkert M, Worm SH, Zevenhoven-Dobbe JC, van der Meer Y, Koster AJ, Mommaas AM, Snijder EJ: **SARS-coronavirus replication is supported by a reticulovesicular network of modified endoplasmic reticulum.** *PLoS Biol* 2008, **6**:e226.
18. Azhar EI, El-Kafrawy SA, Farraj SA, Hassan AM, Al-Saeed MS, Hashem AM, Madani TA: **Evidence for camel-to-human transmission of MERS coronavirus.** *N Engl J Med* 2014, **370**:2499-2505.
19. Reusken CB, Farag EA, Jonges M, Godeke GJ, El-Sayed AM, Pas SD, Raj VS, Mohran KA, Moussa HA, Ghobashy H *et al.*: **Middle East respiratory syndrome coronavirus (MERS-CoV) RNA and neutralising antibodies in milk collected according to local customs from dromedary camels, Qatar, April 2014.** *Euro Surveill* 2014:19.
20. Reusken CB, Haagmans BL, Muller MA, Gutierrez C, Godeke GJ, Meyer B, Muth D, Raj VS, Smits-De Vries L, Corman VM *et al.*: **Middle East respiratory syndrome coronavirus neutralising serum antibodies in dromedary camels: a comparative serological study.** *Lancet Infect Dis* 2013, **13**:859-866.

21. Haagmans BL, Al Dhahiry SH, Reusken CB, Raj VS, Galiano M, Myers R, Godeke GJ, Jonges M, Farag E, Diab A *et al.*: **Middle East respiratory syndrome coronavirus in dromedary camels: an outbreak investigation.** *Lancet Infect Dis* 2014, **14**:140-145.
22. Drosten C, Meyer B, Muller MA, Corman VM, Al-Masri M, Hossain R, Madani H, Sieberg A, Bosch BJ, Lattwein E *et al.*: **Transmission of MERS-coronavirus in household contacts.** *N Engl J Med* 2014, **371**:828-835.
- This study reports the transmission of MERS in a household setting.
23. Gossner C, Danielson N, Gervelmeyer A, Berthe F, Faye B, Kaasik Aaslav K, Adlhoch C, Zeller H, Penttinen P, Coulombier D: **Human-dromedary camel interactions and the risk of acquiring zoonotic middle east respiratory syndrome coronavirus infection.** *Zoonoses Public Health* 2016, **63**:1-9.
24. Zhou H, Perlman S: **Mouse hepatitis virus does not induce beta interferon synthesis and does not inhibit its induction by double-stranded RNA.** *J Virol* 2007, **81**:568-574.
25. Versteeg GA, Bredenbeek PJ, van den Worm SH, Spaan WJ: **Group 2 coronaviruses prevent immediate early interferon induction by protection of viral RNA from host cell recognition.** *Virology* 2007, **361**:18-26.
26. Matthews KL, Coleman CM, van der Meer Y, Snijder EJ, Frieman MB: **The ORF4b-encoded accessory proteins of Middle East respiratory syndrome coronavirus and two related bat coronaviruses localize to the nucleus and inhibit innate immune signalling.** *J Gen Virol* 2014, **95**:874-882.
27. Chen X, Yang X, Zheng Y, Yang Y, Xing Y, Chen Z: **SARS coronavirus papain-like protease inhibits the type I interferon signaling pathway through interaction with the STING-TRAF3-TBK1 complex.** *Protein Cell* 2014, **5**:369-381.
28. Zust R, Cervantes-Barragan L, Habjan M, Maier R, Neuman BW, Ziebuhr J, Szretter KJ, Baker SC, Barchet W, Diamond MS *et al.*: **Ribose 2'-O-methylation provides a molecular signature for the distinction of self and non-self mRNA dependent on the RNA sensor Mda5.** *Nat Immunol* 2011, **12**:137-143.
29. Menachery VD, Yount BL Jr, Josset L, Gralinski LE, Scobey T, Agnihothram S, Katze MG, Baric RS: **Attenuation and restoration of severe acute respiratory syndrome coronavirus mutant lacking 2'-o-methyltransferase activity.** *J Virol* 2014, **88**:4251-4264.
30. Frieman MB, Chen J, Morrison TE, Whitmore A, Funkhouser W, Ward JM, Lamirande EW, Roberts A, Heise M, Subbarao K *et al.*: **SARS-CoV pathogenesis is regulated by a STAT1 dependent but a type I, II and III interferon receptor independent mechanism.** *PLoS Pathog* 2010, **6**:e1000849.
31. Niemeyer D, Zillinger T, Muth D, Zielecki F, Horvath G, Suliman T, Barchet W, Weber F, Drosten C, Muller MA: **Middle East respiratory syndrome coronavirus accessory protein 4a is a type I interferon antagonist.** *J Virol* 2013, **87**:12489-12495.
32. Siu KL, Yeung ML, Kok KH, Yuen KS, Kew C, Lui PY, Chan CP, Tse H, Woo PC, Yuen KY *et al.*: **Middle east respiratory syndrome coronavirus 4a protein is a double-stranded RNA-binding protein that suppresses PACT-induced activation of RIG-I and MDA5 in the innate antiviral response.** *J Virol* 2014, **88**:4866-4876.
33. Yang Y, Zhang L, Geng H, Deng Y, Huang B, Guo Y, Zhao Z, Tan W: **The structural and accessory proteins M, ORF 4a, ORF 4b, and ORF 5 of Middle East respiratory syndrome coronavirus (MERS-CoV) are potent interferon antagonists.** *Protein Cell* 2013, **4**:951-961.
34. Zhao J, Li K, Wohlford-Lenane C, Agnihothram SS, Fett C, Zhao J, Gale MJ Jr, Baric RS, Enjuanes L, Gallagher T *et al.*: **Rapid generation of a mouse model for Middle East respiratory syndrome.** *Proc Natl Acad Sci U S A* 2014, **111**:4970-4975.
- The first study to describe the development of a small animal model for MERS-CoV.
35. Agrawal AS, Garron T, Tao X, Peng BH, Wakamiya M, Chan TS, Couch RB, Tseng CT: **Generation of a transgenic mouse model of Middle East respiratory syndrome coronavirus infection and disease.** *J Virol* 2015, **89**:3659-3670.
36. Pascal KE, Coleman CM, Mujica AO, Kamat V, Badithe A, Fairhurst J, Hunt C, Strein J, Berrebi A, Sisk JM *et al.*: **Pre- and postexposure efficacy of fully human antibodies against Spike protein in a novel humanized mouse model of MERS-CoV infection.** *Proc Natl Acad Sci U S A* 2015, **112**:8738-8743.
- This study report the use of novel technologies for rapidly developing neutralizing human antibodies and a humanized mice model for MERS.
37. de Wit E, Rasmussen AL, Falzarano D, Bushmaker T, Feldmann F, Brining DL, Fischer ER, Martellaro C, Okumura A, Chang J *et al.*: **Middle East respiratory syndrome coronavirus (MERS-CoV) causes transient lower respiratory tract infection in rhesus macaques.** *Proc Natl Acad Sci U S A* 2013, **110**:16598-16603.
38. Falzarano D, de Wit E, Feldmann F, Rasmussen AL, Okumura A, Peng X, Thomas MJ, van Doremalen N, Haddock E, Nagy L *et al.*: **Infection with MERS-CoV causes lethal pneumonia in the common marmoset.** *PLoS Pathog* 2014, **10**:e1004250.
39. Haagmans BL, van den Brand JM, Procvacia LB, Raj VS, Stittelaar KJ, Getu S, de Waal L, Bestebroer TM, van Amerongen G, Verjans GM *et al.*: **Asymptomatic Middle East respiratory syndrome coronavirus infection in rabbits.** *J Virol* 2015, **89**:6131-6135.
40. Johnson RF, Via LE, Kumar MR, Cornish JP, Yellayi S, Huzella L, Postnikova E, Oberlander N, Bartos C, Ork BL *et al.*: **Intratracheal exposure of common marmosets to MERS-CoV Jordan-n3/2012 or MERS-CoV EMC/2012 isolates does not result in lethal disease.** *Virology* 2015, **485**:422-430.
41. Al-Abdallat MM, Payne DC, Alqasrawi S, Rha B, Tohme RA, Abedi GR, Al Nsour M, Iblan I, Jarour N, Farag NH <RT-AL>: **Hospital-associated outbreak of Middle East respiratory syndrome coronavirus: a serologic, epidemiologic, and clinical description.** *Clin Infect Dis* 2014, **59**:1225-1233.
42. Janice Oh HL, Ken-En Gan S, Bertoletti A, Tan YJ: **Understanding the T cell immune response in SARS coronavirus infection.** *Emerg Microbes Infect* 2012, **1**:e23.
43. Tang F, Quan Y, Xin ZT, Wrammert J, Ma MJ, Lv H, Wang TB, Yang H, Richardus JH, Liu W *et al.*: **Lack of peripheral memory B cell responses in recovered patients with severe acute respiratory syndrome: a six-year follow-up study.** *J Immunol* 2011, **186**:7264-7268.
44. Gretebeck LM, Subbarao K: **Animal models for SARS and MERS coronaviruses.** *Curr Opin Virol* 2015, **13**:123-129.
45. Roberts A, Deming D, Paddock CD, Cheng A, Yount B, Vogel L, Herman BD, Sheahan T, Heise M, Genrich GL *et al.*: **A mouse-adapted SARS-coronavirus causes disease and mortality in BALB/c mice.** *PLoS Pathog* 2007, **3**:e5.
46. Zhao J, Zhao J, Van Rooijen N, Perlman S: **Evasion by stealth: inefficient immune activation underlies poor T cell response and severe disease in SARS-CoV-infected mice.** *PLoS Pathog* 2009, **5**:e1000636.
47. Smits SL, de Lang A, van den Brand JM, Leijten LM, van IWF, Eijkemans MJ, van Amerongen G, Kuiken T, Andeweg AC, Osterhaus AD *et al.*: **Exacerbated innate host response to SARS-CoV in aged non-human primates.** *PLoS Pathog* 2010, **6**:e1000756.
48. Zhao J, Zhao J, Legge K, Perlman S: **Age-related increases in PGD(2) expression impair respiratory DC migration, resulting in diminished T cell responses upon respiratory virus infection in mice.** *J Clin Invest* 2011, **121**:4921-4930.
49. Zhou J, Chu H, Li C, Wong BH, Cheng ZS, Poon VK, Sun T, Lau CC, Wong KK, Chan JY *et al.*: **Active replication of Middle East respiratory syndrome coronavirus and aberrant induction of inflammatory cytokines and chemokines in human macrophages: implications for pathogenesis.** *J Infect Dis* 2014, **209**:1331-1342.
- This study reports that MERS-CoV can infect human macrophages productively and induces a dysregulated response leading to disease pathogenesis.
50. Chu H, Zhou J, Wong BH, Li C, Chan JF, Cheng ZS, Yang D, Wang D, Lee AC, Li C *et al.*: **Middle east respiratory syndrome**

- coronavirus efficiently infects human primary T lymphocytes and activates the extrinsic and intrinsic apoptosis pathways.** *J Infect Dis* 2015. jiv380v2-jiv380.
51. Josset L, Menachery VD, Gralinski LE, Agnihothram S, Sova P, Carter VS, Yount BL, Graham RL, Baric RS, Katze MG: **Cell host response to infection with novel human coronavirus EMC predicts potential antivirals and important differences with SARS coronavirus.** *MBio* 2013, **4** e00165-00113.
52. Li W, Shi Z, Yu M, Ren W, Smith C, Epstein JH, Wang H, Crameri G, Hu Z, Zhang H *et al.*: **Bats are natural reservoirs of SARS-like coronaviruses.** *Science* 2005, **310**:676-679.
53. Vijgen L, Keyaerts E, Moes E, Thoelen I, Wollants E, Lemey P, Vandamme AM, Van Ranst M: **Complete genomic sequence of human coronavirus OC43: molecular clock analysis suggests a relatively recent zoonotic coronavirus transmission event.** *J Virol* 2005, **79**:1595-1604.