

Video Article

Experimental Protocol to Determine the Chloride Threshold Value for Corrosion in Samples Taken from Reinforced Concrete Structures

Ueli M. Angst¹, Carolina Boschmann¹, Matthias Wagner², Bernhard Elsener^{1,3}¹Institute for Building Materials, ETH Zurich²Tecnotest AG³Department of Chemical and Geological Science, University of CagliariCorrespondence to: Ueli M. Angst at uangst@ethz.chURL: <https://www.jove.com/video/56229>DOI: [doi:10.3791/56229](https://doi.org/10.3791/56229)

Keywords: Engineering, Issue 126, Corrosion, chlorides, chloride threshold, critical chloride content, infrastructure, concrete, reinforcing steel, durability, service life

Date Published: 8/31/2017

Citation: Angst, U.M., Boschmann, C., Wagner, M., Elsener, B. Experimental Protocol to Determine the Chloride Threshold Value for Corrosion in Samples Taken from Reinforced Concrete Structures. *J. Vis. Exp.* (126), e56229, doi:10.3791/56229 (2017).

Abstract

The aging of reinforced concrete infrastructure in developed countries imposes an urgent need for methods to reliably assess the condition of these structures. Corrosion of the embedded reinforcing steel is the most frequent cause for degradation. While it is well known that the ability of a structure to withstand corrosion depends strongly on factors such as the materials used or the age, it is common practice to rely on threshold values stipulated in standards or textbooks. These threshold values for corrosion initiation (C_{crit}) are independent of the actual properties of a certain structure, which clearly limits the accuracy of condition assessments and service life predictions. The practice of using tabulated values can be traced to the lack of reliable methods to determine C_{crit} on-site and in the laboratory.

Here, an experimental protocol to determine C_{crit} for individual engineering structures or structural members is presented. A number of reinforced concrete samples are taken from structures and laboratory corrosion testing is performed. The main advantage of this method is that it ensures real conditions concerning parameters that are well known to greatly influence C_{crit} , such as the steel-concrete interface, which cannot be representatively mimicked in laboratory-produced samples. At the same time, the accelerated corrosion test in the laboratory permits the reliable determination of C_{crit} prior to corrosion initiation on the tested structure; this is a major advantage over all common condition assessment methods that only permit estimating the conditions for corrosion after initiation, *i.e.*, when the structure is already damaged.

The protocol yields the statistical distribution of C_{crit} for the tested structure. This serves as a basis for probabilistic prediction models for the remaining time to corrosion, which is needed for maintenance planning. This method can potentially be used in material testing of civil infrastructures, similar to established methods used for mechanical testing.

Video Link

The video component of this article can be found at <https://www.jove.com/video/56229/>

Introduction

Corrosion of steel in concrete, triggered by the penetration of chlorides through the concrete, is the most frequent cause of the premature degradation of reinforced and pre-stressed concrete structures, and thus presents one of the most important challenges in civil engineering^{1,2,3,4}. Industrialized countries typically have a large inventory of aging concrete infrastructures, built in the second half of the last century, and thus with a history of several decades of exposure to marine climate or deicing salts used on roads. Being able to reliably assess the condition of these structures, *i.e.*, the risk for corrosion, forms the basis for planning maintenance work and for infrastructure management, in general.

The established approach in engineering for managing chloride-induced steel corrosion in concrete is based on a chloride threshold value (also termed critical chloride content, C_{crit})^{1,5,6}. According to this concept, corrosion initiation is thought to occur as soon as the chloride concentration in the concrete at the steel surface exceeds the C_{crit} threshold. Thus, assessing the condition of existing structures and estimating the remaining service life typically rely on determining the chloride content at different depths in the concrete, particularly at the depth of the embedded reinforcing steel. A number of reliable and standardized methods exist to measure this chloride concentration in samples of concrete^{7,8}. Comparing the results to C_{crit} provides the basis for the assessment of corrosion risk, and planning the type and the extent of repair measures. However, this approach requires knowledge of C_{crit} .

Different international standards and recommendations, as well as text books, stipulate values for C_{crit} ^{1,3,9,10,11}. These are typically around 0.4% chloride by weight of cement, based on long-term experience or early studies^{12,13}. However, it is well known that the actual resistance against C_{crit} of a certain structure or structural member is strongly influenced by the materials used, by the age of the structure, and by exposure history and conditions^{1,5}. Thus, it is generally accepted that experience from one structure should only be applied to other structures with caution.

Despite this, it is common engineering practice to use tabulated C_{crit} values, independent of the actual structure. This can be explained by the huge scatter of C_{crit} in the literature and by the lack of reliable methods to determine C_{crit} on-site and in the laboratory⁵. The approach of using tabulated threshold values in durability assessments is in contrast to structural considerations in condition assessments of aging concrete structures. In the latter case, there exist a number of standardized test methods to determine mechanical properties, such as the strength of the materials in the structure (concrete, reinforcing steel), to be used in the calculations of the structural behavior.

In this work, an experimental protocol to determine C_{crit} on samples taken from engineering structures is presented. The approach is based on drilling cores of reinforced concrete in parts of concrete structures where corrosion has not yet initiated. These samples are transferred to the laboratory where they are subjected to an accelerated corrosion test in order to study the conditions for corrosion initiation. The main advantage of the proposed method is that the samples stem from structures and thus exhibit real conditions concerning a number of parameters that are well known to greatly influence C_{crit} and which cannot be representatively mimicked in laboratory-produced samples. This includes the type and the age of the concrete (young laboratory concrete versus mature site-produced concrete), the type and surface condition of the reinforcing steel used at the time of construction, and in general the properties of the steel-concrete interface¹⁴. Together with the accuracy of laboratory measurement methods, this approach permits the reliable determination of C_{crit} for specific structures or structural members.

Application of the suggested protocol in engineering practice will - compared with the common practice of using a constant value for C_{crit} - enhance the accuracy of condition assessments and the predictive power of models to analyze the remaining service life. The expected strong increase in repair works of our built infrastructure over the coming decades¹⁵ poses an urgent need for such an improvement in engineering of corroding infrastructures.

Protocol

1. Sampling on the Engineering Structure

1. Select **test areas** in the concrete structure by taking into account the note below.
NOTE: A **test area** is the area from which several samples will be taken. A test area should be located within one structural member (presumably from one concrete batch), and exhibit homogeneous exposure to the environment (for instance, avoid significant differences in sampling height in columns or walls). Thus, several test areas may be selected within one engineering structure. As an additional requirement, the test area needs to be free of corrosion damage. This can be verified based on the results of established inspection methods, including non-destructive testing such as potential mapping^{16,17,18}. Note that chloride penetration may already have occurred in the structural member under consideration. This does not affect the validity of the test method described here, but may influence the time needed for the corrosion testing in the laboratory.
2. Within each test area on the structure, choose locations of sampling (**sampling locations**). Choose sampling locations that are free from honeycombs, cracks, spalling, or other signs of locally poor concrete cover quality or deterioration.
 1. Locate the reinforcing steel bars in the concrete by means of a non-destructive, handheld scanning device commonly known as "reinforcing steel detector"¹⁹. Move the steel detector both in horizontal and vertical directions over the concrete surface within the test area and mark (using chalk) each reinforcing steel bar temporarily on the concrete surface (grid shape).
 2. Select locations for core-drilling of cores with a diameter of at least 150 mm; Mark and label them on the concrete surface (using chalk). Avoid sampling intersections of reinforcing bars within the core. Select the locations in such a way that the reinforcing steel bar will be as centrally located as possible within the core.
NOTE: Make sure to select those steel bars that are of interest for the assessment of the structure (usually the layer with the lowest cover depth); it is particularly important to distinguish between vertically and horizontally oriented bars as this has an influence on the corrosion performance²⁰.
 3. To account for the variability inherent to C_{crit} , and to be able to provide statistical data, select a minimum of 5 (ideally 10) locations for sampling within a test area.
 4. Consider **structural implications** with respect to the number and position of cores drilled from the structure in order to avoid any critical weakening of the structure caused by the sampling.
 5. Document the position of all samples within the structural member accurately before sampling (photographs, sketches showing distances to edges, etc.)
NOTE: This may also include documentation of on-site measured parameters at the corresponding locations such as electrochemical steel potentials^{16,17,18}, cover depth measurements¹⁹, or other non-destructive test results such as concrete resistivity.
3. **Drill the concrete cores** (minimum diameter of 150 mm) containing the segment of reinforcing steel according to common procedures and standards²¹.
 1. To avoid damaging the steel-concrete interface, perform the core-drilling carefully (water-cooled drilling, sharp drilling tools, etc.) Adjust the depth of core-drilling depending on the concrete quality and on the cover depth of the reinforcing steel.
NOTE: As a rule of thumb, the length of the core should be at least 2 - 3 times the cover depth. This normally permits breaking the core out of the structure without damaging the steel-concrete interface.
 2. Remove the liquid water from the concrete core surface. Clearly label the core with a water-proof chalk marker.
 3. Wrap the core in a diffusion tight foil to preserve the moisture conditions during transport to the laboratory.

2. Sample Preparation in the Laboratory

Note: Apply these steps to each sample (core) taken from the structure in order to prepare them for laboratory corrosion testing. This serves to accelerate the corrosion test (reducing concrete cover), while preserving the conditions in the core and providing protection from unwanted end-effects (e.g., crevice corrosion).

1. **Adjust the concrete cover** on both the front and back side of the drilled core.
 1. Reduce the concrete cover at the front side (which is the originally exposed side) by water-cooled diamond cutting in order to obtain a final concrete cover thickness of the sample in the range of 15 - 20 mm (**Figure 1a - b**).
 2. Make sure that the concrete cover thickness is uniform at the side to be exposed. Measure the concrete cover at both ends of the reinforcing steel bar (*i.e.*, at the lateral face of the core) with a caliper. If needed, use cutting or polishing tools to eliminate any differences in cover thickness exceeding 1 mm.
 3. Measure the thickness of the concrete behind the reinforcing steel with a caliper or a ruler at the lateral face of the core and ensure that it is ~ 30 - 50 mm (**Figure 1b**). If needed, cut the core with water-cooled diamond cutting.
NOTE: No polishing is required on this side.

2. **Establish a cable connection and protect the reinforcing steel bar ends** from false corrosion initiation during the exposure testing by the following procedure **Figure 1c**.
 1. Use a coring drill with an inner diameter slightly larger (by 2 - 4 mm) than the diameter of the reinforcing steel bar to remove the concrete directly around the steel at each bar end over a length of maximum 10 mm. Scratch remnants of cement paste adhering to the steel surface with help of adequate tools (metallic spatula, small chisel, *etc.*)
 2. Drill a small hole in one of the ends of the steel bars and use a metallic self-tapping screw to fix a cable lug (connected to a copper cable) to the steel bar. Make sure that the cable lug is firmly pressed against the reinforcing steel.
NOTE: The diameter of the screw should be slightly larger (*e.g.*, by 0.1 - 0.2 mm) than the one of the hole drilled in the steel to guarantee a tight and solid connection.
 3. Place the screw thread within the reinforcing steel, and ensure that it does not protrude the reinforcing steel part at any place as this will likely affect the electrochemical measurements and the corrosion behavior.
NOTE: This can be ensured by using short screws and by paying attention to the direction of drilling the hole (parallel to the axis of the steel). It is easier to drill parallel to the axis of the steel bar if the cut face of the steel bar is perpendicular to the bar axis. It is thus important that the reinforcing bars are centrally located within the core, otherwise the cut steel face is not perpendicular to the steel bar axis.
 4. Do not use soldering, spot welding, or similar techniques to establish the electrical cable connection because the heating may influence the steel or the steel-concrete interface in the sample.
 5. Fill the gap created around both steel bar ends with a dense cement paste/mortar/grout by carefully pouring the slurry into the holes. Also coat the screw and lug of the cable connection.
 1. Use a polymer-modified cement-based product for this in order to ensure good adherence and end protection.
NOTE: There exists a range of commercial products marketed as repair mortars or similar (see **Table of Materials**). It is important that the product does not contain a corrosion inhibitor or any other substances affecting the electrochemical behavior of the steel.
 2. Make sure this cement paste/mortar/grout is applied and cured properly, *i.e.*, according to the supplier's instructions.

3. Apply an **epoxy-coating** to limit the exposed surface area.
 1. Prior to applying the coating, allow the concrete surface a few days of drying at room temperature and indoor climate. Avoid aggressive (*e.g.*, in the oven) or long (more than a 1 - 2 weeks) drying of the core as this may change the microstructure of the concrete (cracking), and thus influence the test results.
 2. Coat the lateral surface of the core with an epoxy resin. Also coat the reinforcing steel bar ends and the cable connection (screw, cable lug, *etc.*) (**Figure 1c - D**).
 3. With the same epoxy resin, also coat the end parts of the exposed concrete surface at the side of the core, which was previously closest to the structural concrete surface (**Figure 1d**). Leave an exposed (uncoated) length along the steel bar on this side of 60 - 80 mm.
 4. Leave the upper concrete face uncoated (*i.e.*, the side opposite to the exposed side, compare **Figure 1d**).
NOTE: The epoxy resin used should be suitable for application on concrete (stable in alkaline conditions, easy to spread, *e.g.*, with a brush, *etc.*)
 5. Apply the coating, so that it forms a diffusion tight barrier towards the later exposure to the chloride containing solution. Ensure that the coating thickness is at least 2 mm. Check that no pores and holes are visible in the coating. If needed, apply several layers of the resin.
 6. The protocol can be paused here; wrap the sample again in a diffusion tight foil.

3. Corrosion Test

1. Prepare the **setup for exposure to solution**.
 1. Place all the samples in a tank, with the sample side exhibiting 15 - 20 mm concrete cover thickness facing downwards. Mount the samples on small spacers to permit exposure of the solution to the samples from their underside (**Figure 2**).
 2. Choose a tank with dimensions permitting a distance between the concrete samples and between the samples and the tank walls of at least 4 cm; the height of the tank is ideally in the range 15 - 30 cm.

2. Prepare the instrumentation for **data logging**.
 1. Place a reference electrode in the exposure solution (**Figure 2**).
NOTE: For a reference electrode, any type of stable reference electrode suitable for immersion in the exposure solution can be used (for instance an Ag/AgCl/KCl_{sat} reference electrode). Special measures may be needed to avoid contamination of the exposure solution by the electrolyte of the reference electrode and *vice versa*.
 2. Connect all samples to an automated data logger, which can individually measure the potentials of the reinforcing steel bars vs. the common reference electrode (**Figure 2**). Use a data logger with an input impedance higher than 10⁷ Ohm.

3. Set the measuring interval of the data logger to at least 4 measurements per day for each sample; preferentially, use an interval of 1 h for each sample.

3. Start exposure to chloride-free solution.

Note: The beginning of exposure to solution corresponds to time $t_0 = t = 0$, for each sample.

1. Fill the tank with tap water (pH within 6.5 - 8.0, chloride-free, drinking water quality). Make sure that the water level is such that all lower sides of the core samples are in contact with solution, but that they are not totally immersed (*i.e.*, with the upper sample face above the water level). Maintain contact between the reference electrode and exposure solution (**Figure 2**).
2. Immediately start data logging, *i.e.*, measuring the potentials of all samples vs. the reference electrode.
3. Monitor the potentials for over 1 - 2 weeks and consider that the potentials are expected to reach stable values, in a range indicating steel passivity.
NOTE: Typically, this is around -100 to +200 mV vs. Ag/AgCl/KCl_{sat}¹.
4. In some cases, the samples assume potentials clearly more negative than -100; immediately inspect the samples in more detail (see section 5). Perform this step also if the potential varies markedly during exposure to the chloride-free solution.

4. Start exposure to chlorides.

1. After 1 - 2 weeks in chloride-free solution, replace the exposure solution with a prepared solution of 3.5% NaCl by weight. Use deionized water to prepare this chloride solution. Use a volume of the chloride solution equal to the initial chloride-free solution (same depth of immersion). Close the exposure tank with a lid (recommended) to limit evaporation of the solution and related changes in chloride concentration.
2. During chloride exposure, regularly (at least once per 2 weeks) check the water level with respect to the samples. If needed, add deionized water. Limit renewing the entire exposure solution to a minimum because this promotes leaching of the concrete.
3. Continue monitoring the potentials of the samples and regularly (at each twice a week) check the corrosion state of each sample by evaluating the recorded evolution of potentials over time of each sample and by considering the criterion for corrosion initiation defined in section 3.5.
4. After 60 days, increase the NaCl concentration in the solution to 7% by weight. After 120 days, increase the NaCl concentration in the solution to 10% by weight. After this, maintain the chloride concentration at this level.

5. Evaluate the monitored potentials over time in order to detect corrosion initiation.

Note: During exposure, the samples typically exhibit relatively stable potentials within approximately +/- 30 mV of the initial values of exposure to chloride-free water. This potential range will be referred to as "passive level" herein (**Figure 3**). It may be different for each individual sample.

1. When evaluating the recorded steel potentials during exposure, use the following **criterion for corrosion initiation** to check the corrosion state of each specimen. The following two conditions need to be fulfilled for corrosion initiation (**Figure 3**):
 1. Check if the potential decreases by more than 150 mV from the passive level within a time period of 5 days or shorter.
 2. During the following 10 days, check if the potential remains stabled on the achieved negative level, decreases further, or recovers by a maximum of 50 mV.
NOTE: For more background information about this criterion for the detection of corrosion initiation see the **Discussion**.
2. Once this criterion for corrosion initiation is satisfied, immediately remove the sample from the exposure solution and proceed as described in section 4. Document the time to corrosion initiation (t_{ni}) of this sample (**Figure 3**). Continue the exposure test with the remaining samples.
3. If the potential decrease from the passive level is less than 150 mV, observe the sample closely over the coming exposure time. If the potential decreases further and achieves a stable level, consider this as a change in corrosion state.
 1. Pay special attention to such samples by checking the corrosion state with alternative measurements (*e.g.*, measuring the linear polarization resistance²²) or by finally analyzing them as described in section 4. If the time of corrosion initiation cannot clearly be ascribed, reject the sample.
4. If the potential drop is pronounced (exceeding 150 mV within a few days), but followed by an increase in potential over the following days towards the initial passive level (**Figure 3**), leave the sample in the exposure solution for further monitoring.
5. Pay special attention to situations where all potentials of the samples exposed in the same exposure tank undergo simultaneous changes in potential. If this occurs, immediately check the reference electrode, and fix it or replace it with a new one if needed.
NOTE: Exchanging the solution or increasing the chloride concentration typically leads to shifts in potential. This may be related to establishing different diffusion potentials at both the junctions of the exposure solution/reference electrode or exposure solution/concrete sample²³. These changes affect all samples exposed in the same tank similarly. They do not indicate changes in the corrosion state.
NOTE: If the reference electrode is unstable or leaks into the solution, it will exhibit a drift. As a consequence, all monitored steel potentials will show the same trend over time. This does not indicate changes in the corrosion state.

4. Sample Analysis after Corrosion Initiation

1. Split the sample to remove the steel bar.

1. Upon withdrawal of a sample from the exposure solution, split (as in step 4.1.2) the concrete core for further analyses and for visual examination of the steel surface and of the concrete at the steel-concrete interface.
2. Cut the concrete core from its rear side (the one not exposed to the solution) with a water-cooled diamond cutting blade (**Figure 4**). Make sure that the section is perpendicular to the rear surface and aligned parallel to the reinforcing steel bar. To avoid damaging the steel bar make sure that the depth of cutting is lower (by approximately 10 mm) than the concrete cover thickness on this side.
3. Insert a chisel or a similar tool and split the concrete core into two halves; this will divide the concrete around the steel bar.

4. Gently remove the reinforcing steel bar from the concrete; this leaves the two halves of the concrete sample with the imprints of the steel bar (**Figure 5a**).
2. **Visually examine the steel-concrete interface.**
 1. Immediately document (photographs, drawings, etc.) the visual appearance of the steel-concrete interface by examining both the steel surface and the steel bar imprints in the concrete. Pay attention to the following.
 2. Document the location and morphology of corrosion.
NOTE: The site(s) of corrosion initiation can usually be easily identified by precipitated corrosion products (**Figure 5a**). Mark the number and position of these spots. The color of the corrosion products is also of interest. Typically, upon splitting, they are dark/black/greenish. When exposed to air, they become brown/red.
 3. Check the specimen for false corrosion initiation, *i.e.*, corrosion that has initiated at or close to the steel bar ends. If this is the case, reject the sample and note that no C_{crit} can be determined.
NOTE: Corrosion that initiates during the test at or close to the steel bar ends, *i.e.*, within 15 mm of the steel bar ends, is considered false corrosion initiation. This may be due to crevice situations, insufficient steel bar end protection measures (*e.g.*, poor grout filling or porous epoxy coating), or because the metallic screw for the cable connection protrudes the steel bar (sections 2.2 and 2.3).
 4. Document voids or pores in the concrete. Take note of whether the location of voids or pores coincides with the location(s) of corrosion initiation.
 5. Document any distinctive features such as cracks, honeycombs, coarse aggregates, foreign matter, tie wires, spacers, etc., in the concrete and their position with respect to the location(s) of corrosion initiation.
3. **Measure the carbonation depth.**
 1. Immediately after documentation, spray the split concrete surfaces with phenolphthalein solution and determine the carbonation depth²⁴.
NOTE: It is crucial to note whether the carbonation depth reached the steel surface, and if not, what the distance of the carbonation depth to the steel bar. This must be reported together with the results.
4. **Perform chloride analyses and determine C_{crit} .**
 1. On both halves of the concrete core, remove the parts that were epoxy-coated by means of water-cooled diamond cutting (**Figure 6a**).
 2. From the obtained prisms, remove the concrete in the cover zone by means of water-cooled diamond cutting down to 2 mm to the steel bar (**Figure 6b**). Dry the concrete at 105 °C overnight.
 3. Subsequently, grind the concrete and collect the grinding powder; the thickness of this grinding step is 4 mm (**Figure 6c**). This yields, from each half of the concrete core, a sample of concrete powder at the depth of the steel bar +/- 2 mm.
 4. Dry the obtained concrete powder samples at 105 °C to a constant weight. Analyze the acid-soluble chloride concentration in the dried concrete powder according to standards^{7,8}. Compute the average of the two values.
NOTE: The result is the chloride content as a percentage by weight of the concrete.
 5. If the cement content of the concrete in the specific sample used for chloride analysis can be determined (*e.g.*, by means of suitable methods^{25,26,27}), convert the chloride content to percentage by weight of cement.
 6. Document the result of the chloride analysis, which is the critical chloride content C_{crit} for the specific sample. Make sure to indicate if the value is expressed in terms of percentage by weight of concrete or by weight of cement.
5. **Document the results as a test report for each sample.**
 1. Report all documented effects from the visual inspection (section 4.2) together with the test results (recorded potentials over time, time to corrosion initiation, carbonation depth, and C_{crit}).

5. Handling Special Situations

1. If **negative potentials prior to chloride exposure** are observed, *i.e.*, if the steel potential becomes clearly negative during the initial exposure to chloride-free solution (section 3.3), give special consideration to the following.
 1. Consider an event of **false corrosion initiation**.
 1. Verify false corrosion initiation by removing the steel bar ends by cutting at each steel bar end the concrete from the sample (water-cooled diamond cutting). Remove up to ~ 20 mm concrete at each side.
 2. Measure again the potential of the steel by placing a reference electrode with the help of a wetted sponge on the exposed concrete surface and by electrically contacting the cut face of the steel bar.
 3. If the potential is still comparatively negative, reject the sample.
 4. If the potential is in the range of the passive levels of the other samples of the same series, consider re-using the sample to determine C_{crit} . In this case, proceed to step 2.2 of the protocol. When reporting the results, indicate that this sample was smaller (shorter exposed steel bar length) than the other ones.
 2. If false corrosion initiation can be excluded, check if the concrete at the steel depth was already **carbonated** and consider determining the chloride concentration at the steel depth. If carbonation or a very high chloride concentration explains the initiation of corrosion upon wetting, document this in the report of the test and note that no C_{crit} can be determined in this case.
NOTE: This can occur if the concrete at the steel depth was already carbonated and/or contained a sufficient amount of chloride to promote corrosion upon wetting. This may be the case when samples were taken from a structure in a dry period, *i.e.*, when no active corrosion was occurring in the structure and thus, no corrosion could be detected by means of the inspection methods described in section 1.

Representative Results

Figure 7 displays typical steel potentials monitored during chloride exposure in the laboratory. Both examples show that the potential may drop significantly within a very short time, but that the corrosion process may not yet stably propagate, which becomes apparent through an increase of the potential towards its initial passive level. In this protocol, the time of corrosion initiation, *i.e.*, the time at which exposure is stopped and C_{crit} is determined, is defined by a marked potential drop followed by 10 days of negative potentials (see section 3.5.2 and the **Discussion** for more details).

It is common that it may take several months until stable corrosion initiation occurs. This also depends on the initial chloride content already present in the concrete when the samples are taken from the structures. In some cases of the experiments so far conducted, it took more than 1 year until corrosion initiated.

Figure 8 shows an example of C_{crit} measured in 11 samples taken from a more than 40 years old road tunnel in the Swiss alps. All these samples were taken from within an area of 1 - 2 m², thus presumably identically produced and exposed. In this example, the chloride content at the steel surface at the time of sampling was negligible. Additionally, the carbonation front was still far from the steel surface.

Figure 9 shows two examples where the steel potential decreased strongly upon exposure to the chloride-free solution. In one of these specific cases, it was during the subsequent (destructive) examination of the sample found that the concrete at the steel depth was already carbonated. Upon arrival of water at the steel surface, the corrosion process thus immediately started. In the other case, false corrosion initiation occurred at one of the steel bar ends.

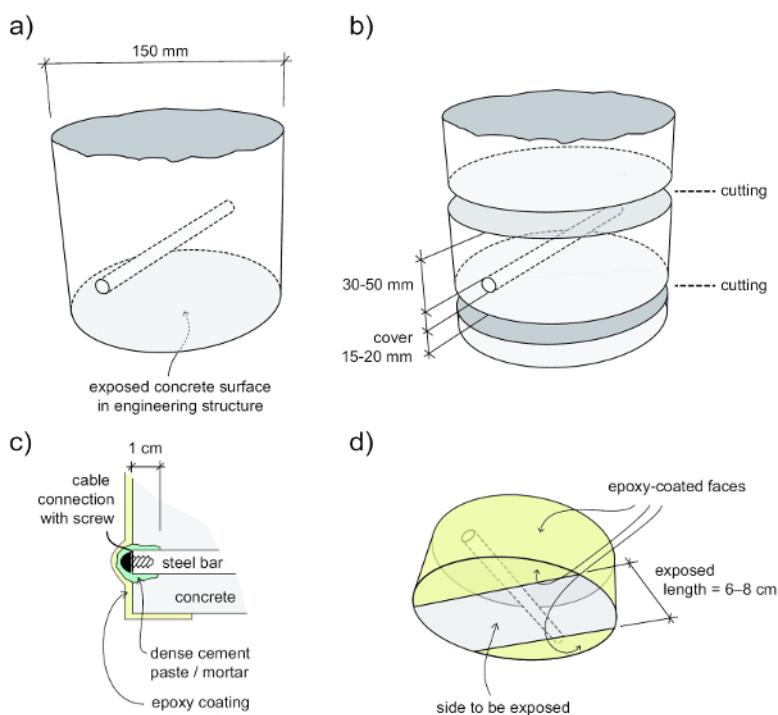

Figure 1. Schematic Drawing of the Sample Taken from a Structure and Treated in the Laboratory: (a) concrete core with an embedded piece of reinforcing steel; (b) reducing the concrete cover on the exposed side and on the back side by water-cooled diamond cutting; (c) steel bar end protection by means of removing some concrete around the steel and replacing it with a dense cement paste/mortar and subsequent epoxy coating; and (d) epoxy-coating on lateral faces and on end zones of the exposed concrete surface. [Please click here to view a larger version of this figure.](#)

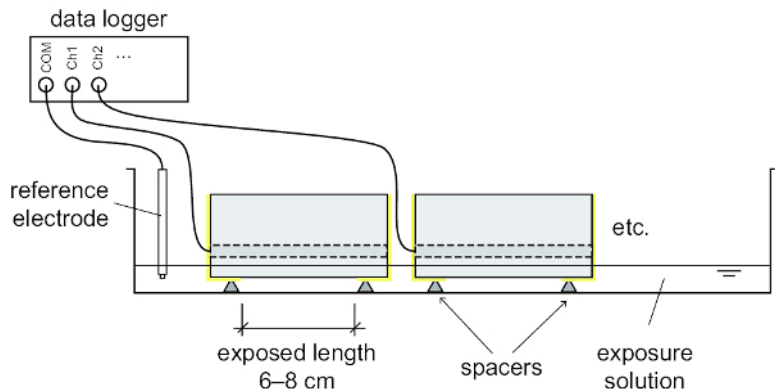

Figure 2. Schematic Drawing of the Setup for the Corrosion Test in the Laboratory. This shows the placement of the samples in the exposure tank. Spacers are used to ensure contact to exposure solution from the bottom sample surface. All samples are connected to a data logger, measuring the potential of each sample vs. a reference electrode placed in the exposure solution. [Please click here to view a larger version of this figure.](#)

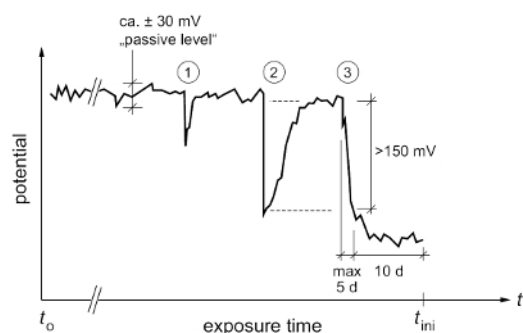

Figure 3. Schematic Drawing of Possible Time-evolutions of the Steel Potential that Illustrates the Criterion for Corrosion Initiation. At point 1, a potential drop by less than 150 mV from the initial "passive level" occurs; at point 2, a potential drop by at least 150 mV occurs, which is followed by repassivation; at point 3, a potential drop of at least 150 mV occurs (within a max. of 5 days) and the achieved negative potential level is sustained over 10 days. At t_{ini} , withdraw the sample from the exposure solution. [Please click here to view a larger version of this figure.](#)

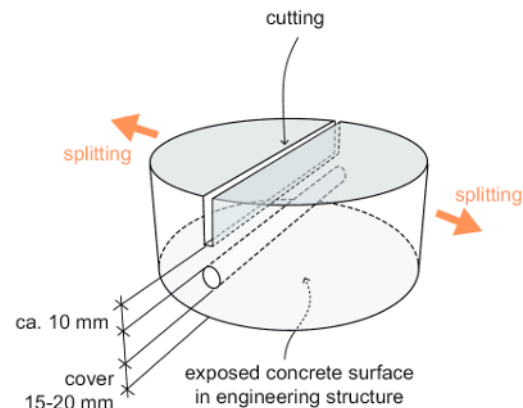

Figure 4. Schematic Drawing Illustrating the Cutting and Splitting of the Concrete Sample after Detection of Corrosion Initiation. First, a "trench" is cut from the rear side, in parallel to the steel bar. By inserting a chisel or a similar tool, the trench can be used to split the sample as indicated by the arrows. [Please click here to view a larger version of this figure.](#)

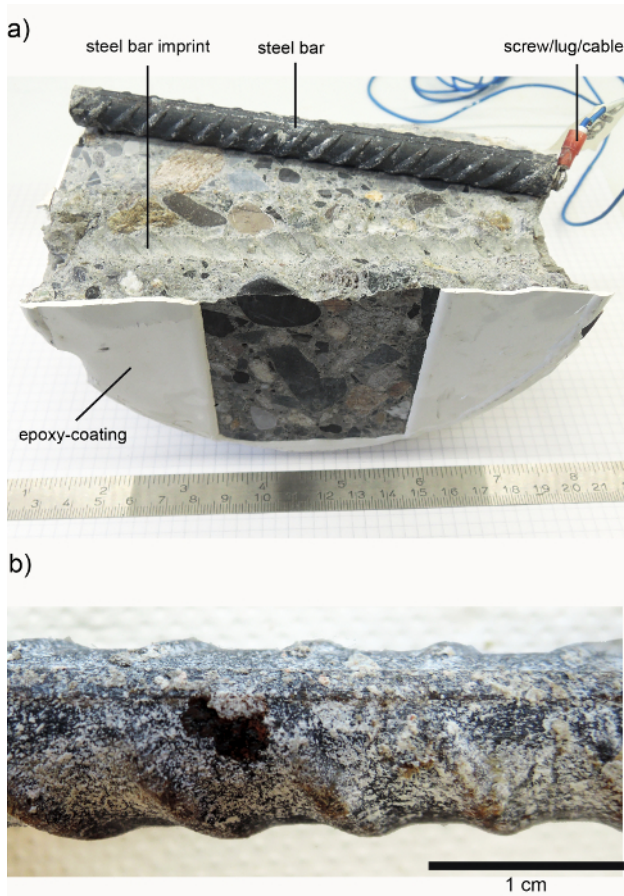

Figure 5. Photographs Illustrating Sample Analysis After Corrosion Initiation. (a) The two halves of the sample after splitting, and (b) a rust spot is visible at the steel surface after corrosion initiation. Photographs from different samples. [Please click here to view a larger version of this figure.](#)

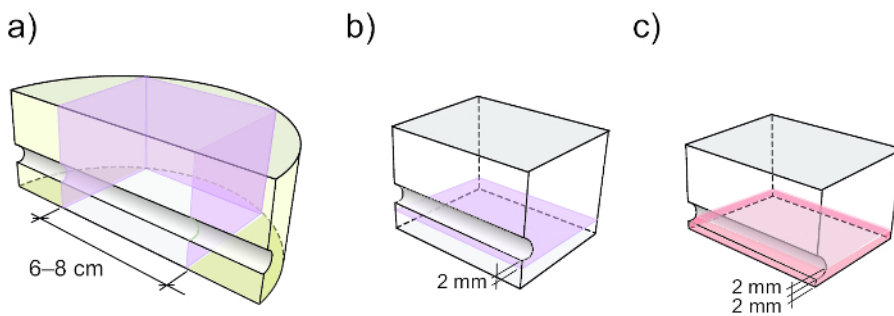

Figure 6. Schematic Drawing Illustrating the Sampling for the Chloride Analysis After Corrosion Initiation: (a) removal of epoxy-coated parts of the split concrete core (purple = cutting planes); (b) removal of the concrete cover down to 2 mm from the steel surface (purple = cutting plane); (c) grinding over a depth interval of ± 2 mm of the steel bar cover depth (red = sampled volume). [Please click here to view a larger version of this figure.](#)

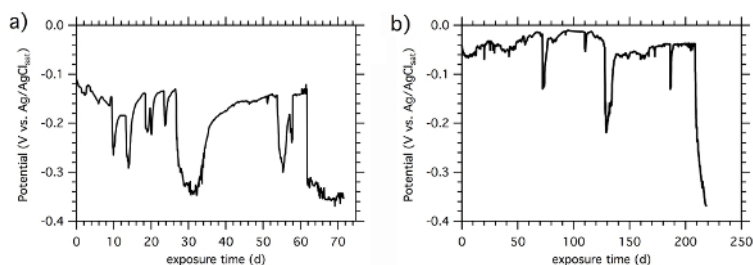

Figure 7. Representative Examples of Measured Potential vs. Time Curves. The typically pronounced potential drops that may be followed by a potential increase (repassivation) until stable corrosion initiation according to the suggested criterion finally initiates. (a) Shows a case where the potential stabilizes on the negative level, and (b) is an example where the potential continues decreasing over the studied period of 10 days. [Please click here to view a larger version of this figure.](#)

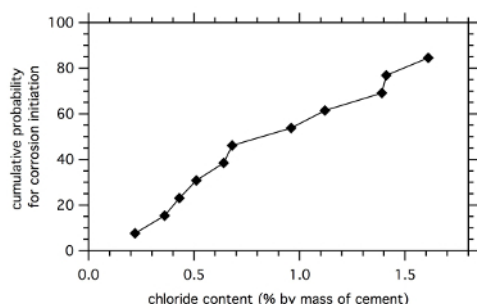

Figure 8. Example of C_{crit} Measured in 11 Samples Taken from Within a Small Concrete Area in a More than 40 Years Old Road Tunnel in the Swiss Alps. [Please click here to view a larger version of this figure.](#)

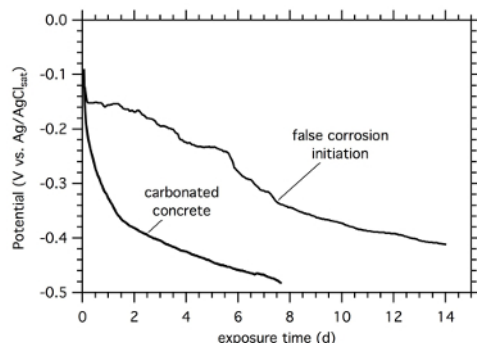

Figure 9. Examples of Marked Potential Decreases Immediately upon Exposure in Chloride-free Solution. In one case, the concrete at the steel depth was already carbonated, thus upon arrival of water at the steel surface, the corrosion process immediately started, leading to a sharp decrease in potential. In the other case, false corrosion initiation occurred at one of the steel bar ends, which here led to a more gradual potential decrease. [Please click here to view a larger version of this figure.](#)

Discussion

The most critical steps for the success of the suggested experimental protocol to determine C_{crit} are those including the measures taken to prevent false corrosion initiation and other steel bar end effects. In this regard, a variety of approaches were tested, among which the here reported protocol was found to yield the best results²⁸. In further tests, this approach permitted decreasing the rate of false initiation to below 10%. On the one hand, this is owing to coating the border area of the exposed concrete surface with epoxy resin, which increases the length of transport of chlorides through the concrete to the steel bar ends considerably. On the other hand, replacing the original concrete around the steel bar at its ends with a dense, highly alkaline cementitious slurry significantly enhances the corrosion resistance in these areas. Such systems, *i.e.*, coating the steel bar ends with a layer of a polymer-modified cementitious material, have proven successful also in other studies^{29,30}.

Another important aspect is the criterion for corrosion initiation. This criterion is based on RILEM technical committee TC-235 that aimed to recommend a test method for the measurement of C_{crit} in samples manufactured in the laboratory³¹. The rationale is that it is well known that onset of corrosion of unpolarized steel embedded in concrete might take place over a long period of time rather than a well-defined instant^{30,32}. Steel may start corroding at relatively low chloride concentrations but if these are not able to sustain the corrosion process, repassivation will occur, which becomes apparent by a potential increase back to the initial passive level. Such depassivation-repassivation events are typically observed in similar studies^{30,33,34}. The chloride concentration measured at a time of stable corrosion is more relevant for practice than the time at which the very first signs of potential deviations from the passive level become apparent. With the suggested criterion, C_{crit} represents the chloride concentration at which corrosion initiates and also stably propagates.

A limitation of the method is that the samples are relatively small, which may have an influence on the results^{35,36}. In order to counteract this, it is suggested to use a relatively high number of samples (ideally 10). The level of confidence depends on the statistical distribution of C_{crit} in

the actual test area. For more details in this regard, refer to reference³⁶. An additional limitation is that the moisture conditions in the laboratory exposure may differ from those of an actual structure. Finally, the detection of corrosion initiation may be difficult in cases where the potential is generally negative, such as in slag cements or other sulfide containing binders.

To the best of our knowledge, this is the first method of C_{crit} determination in engineering structures at a stage prior to corrosion initiation. In contrast to empirical experience from structures, which is by definition obtained after corrosion initiation, this method can be used to measure C_{crit} for specific structures or structural members before corrosion degradation occurs; the results can thus be used to assess the risk of (future) corrosion and to predict the remaining time to corrosion initiation (service life modeling). Thus, this method has the potential to be used in material testing, similar to established methods used for mechanical testing (compressive strength, etc.)

The method is currently applied to a number of different concrete infrastructures in Switzerland. This will broaden the severely limited⁵ knowledge about statistical distributions of C_{crit} in structures. Moreover, it will reveal the influence of different factors such as the age of structures, the construction materials used, etc., and thus provide important information for civil engineers and for decision-makers in infrastructure management.

Disclosures

The authors have nothing to disclose.

Acknowledgements

The work described here was in part financed by the Swiss Federal Roads Office (research project AGB2012/010). We greatly acknowledge the financial support.

References

- Bertolini, L., Elsener, B., Pedferri, P., Redaelli, E., Polder, R. B. *Corrosion of Steel in Concrete: Prevention, Diagnosis, Repair*. 2nd edn, WILEY-VCH (2013).
- British Cement Association. Development of an holistic approach to ensure the durability of new concrete construction. *British Cement Association*. Crowthorne, UK, (1997).
- Condition control and assessment of reinforced concrete structures exposed to corrosive environments. *Fédération Internationale du Béton (fib)*. (2011).
- Angst, U. M., et al. Present and future durability challenges for reinforced concrete structures. *Mater. Corros.* **63** (12), 1047-1051 (2012).
- Angst, U., Elsener, B., Larsen, C. K., Vennesland, Ø. Critical chloride content in reinforced concrete - A review. *Cem. Concr. Res.* **39** (12), 1122-1138 (2009).
- Breit, W., et al. Zum Ansatz eines kritischen Chloridgehaltes bei Stahlbetonbauwerken. *Beton- und Stahlbetonbau*. (5), 290-298 (2011).
- European Standard EN14629: Products and systems for the protection and repair of concrete structures - Test methods - Determination of chloride content in hardened concrete. *European Committee for Standardization*. (2007).
- Standard Test Method for Acid-Soluble Chloride in Mortar and Concrete. *ASTM International*. (2012).
- Erhaltung von Tragwerken - Betonbau (in German). *Schweizerischer Ingenieur- und Architektenverein SIA*. (2011).
- Draft recommendation for repair strategies for concrete structures damaged by reinforcement corrosion. *Mater Struct.* **27** (7), 415-436 (1994).
- Broomfield, J. P. *Corrosion of Steel in Concrete: Understanding, Investigation and Repair*. 2nd edn, CRC Press, (2006).
- Richartz, W. Die Bindung von Chlorid bei der Zementerhärtung (in German). *Zement-Kalk-Gips*. **10** 447-456 (1969).
- Vassie, P. Reinforcement corrosion and the durability of concrete bridges. *Proc. Inst. Civ. Eng. Part 1*. **76** 713-723 (1984).
- Angst, U. M., et al. The steel-concrete interface. *Mater. Struct.* **50** (2), 143 (2017).
- Polder, R. B., Peelen, W. H. A., Courage, W. M. G. Non-traditional assessment and maintenance methods for aging concrete structures - technical and non-technical issues. *Mater. Corros.* **63** (12), 1147-1153 (2012).
- Standard Test Method for Corrosion Potentials of Uncoated Reinforcing Steel in Concrete. *ASTM International*. (2015).
- Planung, Durchführung und Interpretation der Potenzialmessung an Stahlbetonbauten (in German). *Schweizerischer Ingenieur- und Architektenverein SIA*. (2013).
- Merkblatt für Elektrochemische Potentialmessungen zur Detektion von Bewehrungsstahlkorrosion (in German). *Deutsche Gesellschaft für Zerstörungsfreie Prüfung DGZfP*. (2014).
- Merkblatt zur zerstörungsfreien Betondeckungsmessung und Bewehrungsart an Stahl- und Spannbetonbauteilen (in German). *Deutsche Gesellschaft für Zerstörungsfreie Prüfung DGZfP*. (2014).
- Soylev, T. A., François, R. Quality of steel-concrete interface and corrosion of reinforcing steel. *Cem. Concr. Res.* **33** (9), 1407-1415 (2003).
- European Standard EN 12504-1:2009 - Testing concrete in structures. Cored specimens. Taking, examining and testing in compression. *European Committee for Standardization*. (2009).
- Andrade, C., et al. Test methods for on-site corrosion rate measurement of steel reinforcement in concrete by means of the polarization resistance method. *Mater Struct.* **37** (273), 623-643 (2004).
- Angst, U., Vennesland, Ø., Myrdal, R. Diffusion potentials as source of error in electrochemical measurements in concrete. *Mater Struct.* **42** (3), 365-375 (2009).
- European Standard EN 14630: Products and systems for the protection and repair of concrete structures - Test methods - Determination of carbonation depth in hardened concrete by the phenolphthalein method. *European Committee for Standardization*. (2006).
- Gulikers, J. in *Testing and Modelling the Chloride Ingress into Concrete RILEM Proceedings PRO 19*. eds C. Andrade, J. Kropp (2000).
- Standard Test Method for Portland-Cement Content of Hardened Hydraulic-Cement Concrete. *ASTM International*. (2013).
- Boschmann Käthler, C., Angst, U. M., Wagner, M., Elsener, B. Image analysis for determination of cement content in concrete to improve accuracy of chloride analyses. *Cem Concr Res.* (2017).

28. Angst, U., Wagner, M., Elsener, B., Leemann, A., Nygaard, P. v. *Method to determine the critical chloride content of existing reinforced structures, VSS report no. 677, (in German)*. Swiss Federal Roads Office, (2016).
29. Lambert, P., Page, C. L., Vassie, P. R. W. Investigations of reinforcement corrosion: Part 2 - Electrochemical monitoring of steel in chloride-contaminated concrete. *Mater. Struct.* **24** (143), 351-358 (1991).
30. Angst, U. M., Elsener, B., Larsen, C. K., Vennesland, Ø. Chloride induced reinforcement corrosion: Electrochemical monitoring of initiation stage and chloride threshold values. *Corros. Sci.* **53** (4), 1451-1464 (2011).
31. *RILEM technical committee 235-CTC*. (2009) - (2015).
32. Angst, U., Elsener, B., Larsen, C. K., Vennesland, Ø. Chloride induced reinforcement corrosion: Rate limiting step of early pitting corrosion. *Electrochim Acta.* **56** (17), 5877-5889 (2011).
33. Boubitsas, D., Tang, L. The influence of reinforcement steel surface condition on initiation of chloride induced corrosion. *Mater Struct.* **48** (8), 2641-2658 (2015).
34. Pacheco, J. *Corrosion of steel in cracked concrete - chloride microanalysis and service life predictions.*, TU Delft, The Netherlands, (2015).
35. Li, L., Sagüés, A. A. Chloride corrosion threshold of reinforcing steel in alkaline solutions - Effect of specimen size. *Corros.* **60** (2), 195-202 (2004).
36. Angst, U., Rønquist, A., Elsener, B., Larsen, C. K., Vennesland, Ø. Probabilistic considerations on the effect of specimen size on the critical chloride content in reinforced concrete. *Corros. Sci.* **53** (1), 177-187 (2011).