

# Circular DNA Intermediate in the Duplication of Nile Tilapia *vasa* Genes

Koji Fujimura<sup>‡</sup>, Matthew A. Conte, Thomas D. Kocher\*

Department of Biology, University of Maryland, College Park, Maryland, United States of America

## Abstract

*vasa* is a highly conserved RNA helicase involved in animal germ cell development. Among vertebrate species, it is typically present as a single copy per genome. Here we report the isolation and sequencing of BAC clones for Nile tilapia *vasa* genes. Contrary to a previous report that Nile tilapia have a single copy of the *vasa* gene, we find evidence for at least three *vasa* gene loci. The *vasa* gene locus was duplicated from the original site and integrated into two distant novel sites. For one of these insertions we find evidence that the duplication was mediated by a circular DNA intermediate. This mechanism of gene duplication may explain the origin of isolated gene duplicates during the evolution of fish genomes. These data provide a foundation for studying the role of multiple *vasa* genes in the development of tilapia gonads, and will contribute to investigations of the molecular mechanisms of sex determination and evolution in cichlid fishes.

**Citation:** Fujimura K, Conte MA, Kocher TD (2011) Circular DNA Intermediate in the Duplication of Nile Tilapia *vasa* Genes. PLoS ONE 6(12): e29477. doi:10.1371/journal.pone.0029477

**Editor:** Zhanjiang Liu, Auburn University, United States of America

**Received:** July 29, 2011; **Accepted:** November 29, 2011; **Published:** December 22, 2011

**Copyright:** © 2011 Fujimura et al. This is an open-access article distributed under the terms of the Creative Commons Attribution License, which permits unrestricted use, distribution, and reproduction in any medium, provided the original author and source are credited.

**Funding:** This work was supported by grant R01HD058635 from the National Institutes of Health (URL: <http://www.nichd.nih.gov/>). The funders had no role in study design, data collection and analysis, decision to publish, or preparation of the manuscript.

**Competing Interests:** The authors have declared that no competing interests exist.

\* E-mail: [tdk@umd.edu](mailto:tdk@umd.edu)

<sup>‡</sup> Current address: Department of Anatomy, School of Medicine, The Jikei University, Minato-ku, Tokyo, Japan

## Introduction

Fish are the most species-rich group of vertebrates, making up more than half of the 55,000 vertebrate species [1]. Fish are an attractive group of organisms for studying the evolution of sex determination because members of this class exemplify a broad range of various types of sex determination and differentiation [2]. However, the molecular mechanisms by which sex is determined remain largely unclear.

The Nile tilapia *Oreochromis niloticus* is one of the most important cichlid fishes in aquaculture [3] and is also an excellent laboratory model for studies in physiology [4,5], endocrinology [6,7], genomic biology and molecular genetics [8–12] and developmental biology [13–15].

Cichlids in the East African Great Lakes are famous as spectacular examples of explosive adaptive radiation [16,17]. The cichlids have various types of sex determination, and thus provide an opportunity to understand the molecular mechanisms of sex determination. Although there are no gross morphological differences in chromosome structure, sex is determined by a small number of genes in most species of cichlid examined to date [18,19]. The patterns of gene expression in gonadal development of Nile tilapia have been extensively characterized [20].

We recently establish *Tol2*-mediated transgenesis in Nile tilapia with the ultimate goal of using germline-specific expressed promoter to reveal the molecular mechanism of sex differentiation *in vivo* [21]. One candidate for developing a gonad-specific promoter is the *vasa* (also called DDX4) gene. The *vasa* gene encodes a DEAD box (Asp-Glu-Ala-Asp) protein thought to be an ATP-dependent RNA helicase [22]. It was originally characterized in *Drosophila* [23], where it plays a critical role in specification of

the germ cell lineage [24]. The regulatory regions of the teleost *vasa* gene have been used to control transgene expression in fish germ cells (zebrafish [25]; rainbow trout [26]; medaka [27]). The 3'-UTR of the Ostariophysan *vasa* mRNAs plays an important role in their localization to the germ cells [28].

Relatively little has been published about the *vasa* genes of the Nile tilapia. Kobayashi et al. [29] found that the expression pattern of the Nile tilapia *vasa* gene differed between male and female germ cells during gametogenesis. Kobayashi et al. [30] found two isoforms of *vasa* that were differentially expressed during the development of male and female gonads. They suggested that the isoforms were splicing variants of a single copy of the *vasa* gene.

In the current study, we isolated and sequenced BAC clones containing Nile tilapia *vasa* gene sequences. Contrary to the previous report, we find that Nile tilapia have at least three *vasa* gene loci, namely one original locus and two duplicated loci. We investigate their genomic structure, and discuss a duplication mechanism mediated by a circular DNA intermediate that appears to be responsible for at least one of the duplicated copies.

## Results

### BAC clones for Nile tilapia *vasa* gene

We used a 4-step PCR screening of pooled colonies to identify clones containing the *vasa* gene in two Nile tilapia BAC libraries [31,32]. To determine the relationships among these clones, we next looked at contigs assembled from restriction fingerprint data of the BAC clones [32]. Surprisingly, we found that the candidate clones were subdivided into three fingerprint contigs (Figure 1). This result suggested that Nile tilapia have at least three distinct *vasa* gene loci. We chose three BAC clones, b04TI038M07

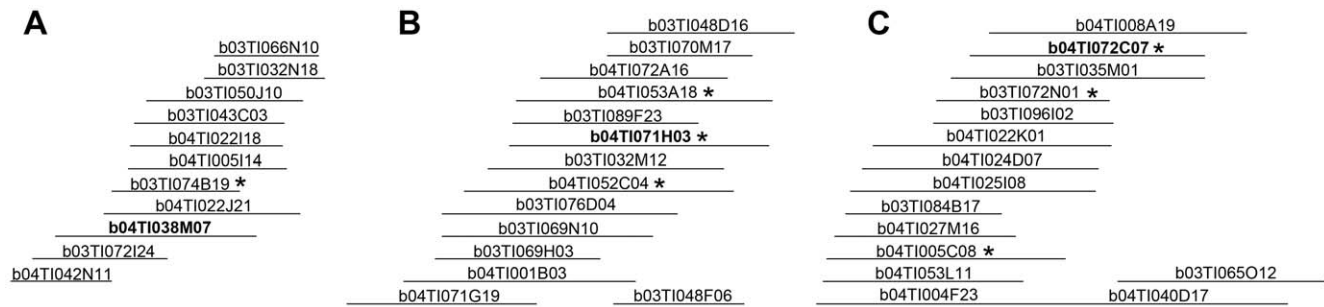

**Figure 1. Three Nile tilapia BAC contigs contain *vasa* gene sequences.** (A) Contig 311, (B) Contig 992 and (C) Contig 542. Asterisks indicate clones identified by a 4-step PCR screening for *vasa* gene sequences. Clones b04TI038M07 (38M07), b04TI071H03 (71H03), b04TI072C07 (72C07) were chosen for sequencing.

doi:10.1371/journal.pone.0029477.g001

(hereafter written simply as 38M07), b04TI071H03 (71H03) and b04TI072C07 (72C07), from contigs 311, 992 and 542 respectively, for further sequence analysis.

### Full sequences of three BAC clones complement the Broad genomic data

We sequenced each of the three candidate clones on a Roche 454 DNA sequencer and assembled them using Newbler. The reads were assembled into 11 contigs for clone 38M07, 5 contigs for 71H03 and 3 contigs for 72C07. We then annotated the contigs by BLAST searching against the stickleback genomic data, and used this information to order the contigs. The final scaffold lengths of the BAC clone were 218,234 bp (38M07), 181,027 bp (71H03) and 189,421 bp (72C07) (Figure S1).

The Broad Institute recently released a first assembly of the Nile tilapia genome based on paired Illumina sequence reads (GenBank #PRJNA59571). We found the sequence of clone 38M07 matched Scaffold\_160, 71H03 matched Scaffold\_19, and 72C07 matched Scaffold\_11 of this assembly (Figure S1). Our BAC data is largely consistent with the corresponding region of each genomic scaffold. However, the Broad genomic data partially lacks sequences for the *vasa* gene in each scaffold, while our BAC data contains all of the exons for *vasa* gene at each location (comparison to mRNA, Genbank Accession #AB032467, ref [29]; Figure S2). This implies that the Broad assembly of the genomic data did not accurately reconstruct the sequences of these recently duplicated genes.

### Nile Tilapia has one original and two extra loci for *vasa* gene

38M07 BAC clone and genome scaffold\_160 have high similarity to a region between the ubiquitin protein ligase E3A (UBE3A) and ankyrin repeat domain 10 (ANKRD10) genes in other teleosts (Figure 2). Since the *vasa* gene of other teleosts is located in this region, clone 38M07 represents the original locus of the *vasa* gene. The genomic organization of this region is conserved among euteleosts including stickleback (*Gasterosteus aculeatus*), pufferfish (*Tetraodon nigroviridis*), and medaka (*Oryzias latipes*), except that the *vasa* gene is inverted in medaka, and that novel genes are predicted in some lineages. Stickleback, medaka and tilapia all have the same novel gene, a predicted protein with no similarity to other genes. The structure of this region is quite different in the more distantly related zebrafish (*Danio rerio*).

BAC clone 71H03 and genome scaffold\_19 are highly similar to a region between the forkhead box P1 (FOXP1) and the microphthalmia-associated transcription factor a (MITFa) genes

in other teleosts (Figure 3). Since the *vasa* gene has not been observed in this location in any other teleosts, the sequence of 71H03 represents a duplication of the *vasa* gene. Aside from the insertion of the *vasa* gene, the genomic organization of this region is conserved among teleosts, except for two novel genes specific to particular lineages. The novel gene closest to FOXP1 is similar to the 3-hydroxybutyrate dehydrogenase type 2 (BDH2) gene, and has been lost in pufferfish (*Takifugu rubripes* and *Tetraodon nigroviridis*). The novel gene closest to MITFa is similar to the pentafunctional arom protein (ARO1) of yeast, and is found in stickleback, medaka and tilapia. The extra *vasa* gene was integrated into this second novel gene.

BAC clone 72C07 and genome scaffold\_11 have high similarities to a region between the six transmembrane epithelial antigen of the prostate (STEAP) family member 3 (STEAP3) and the gamma-aminobutyric acid (GABA) A receptor, gamma 3 (GABRG3) genes of other teleosts (Figure 4). As the *vasa* gene has not been observed in this region of other teleost genomes, this represents a second duplication of the *vasa* gene. The genomic organization is conserved among higher teleosts, except that the diazepam binding inhibitor (DBI) gene is present in *Takifugu* and *Tetraodon*. A novel gene similar to the secretin receptor was found in stickleback, *Takifugu*, *Tetraodon*, medaka and tilapia. The extra *vasa* gene was inserted into the intergenic region between this novel gene and GABRG3.

We then compared the sequences of clone 38M07 to 71H03 and 72C07 (Figure 5). Dotplots show that only a small region around the original *vasa* locus was inserted into 71H03 (Box E–F of Figure 5A) and 72C07 (Box A–B of Figure 5B). The dotplot further shows a difference in the order of segments in 72C07. The downstream region of the 38M07 *vasa* locus is duplicated into the upstream region of the 72C07 *vasa* locus (Box C–D of Figure 5B). This means that the three loci each have an intact gene, and that the regions around them are different.

We predicted the exon-intron structure of *vasa* gene in all three BAC clones by comparison to the putative full-length tilapia mRNA sequence, which is deposited in Genbank (Accession #AB032467, ref [29]; Tables S1, S2, S3). We predicted that the three BAC clones possess 22 exons for the coding region of *vasa* gene, and that the 5'-UTR of the mRNA sequence is on two exons (exon 1, and part of exon 2). For 38M07 and 72C07, the 3'-UTR of the cDNA sequence followed after the stop codon on a part of exon 23 and continued on exon 24, while in 71H03 exons 23 and 24 are adjacent without an intron. The predicted *vasa* gene sequences of the three BAC clones were slightly different from that of the mRNA (38M07 98.0%; 71H03 98.9%; 72C07 97.1%). Differences were also found in the lengths of exons 6, 10, 12 and

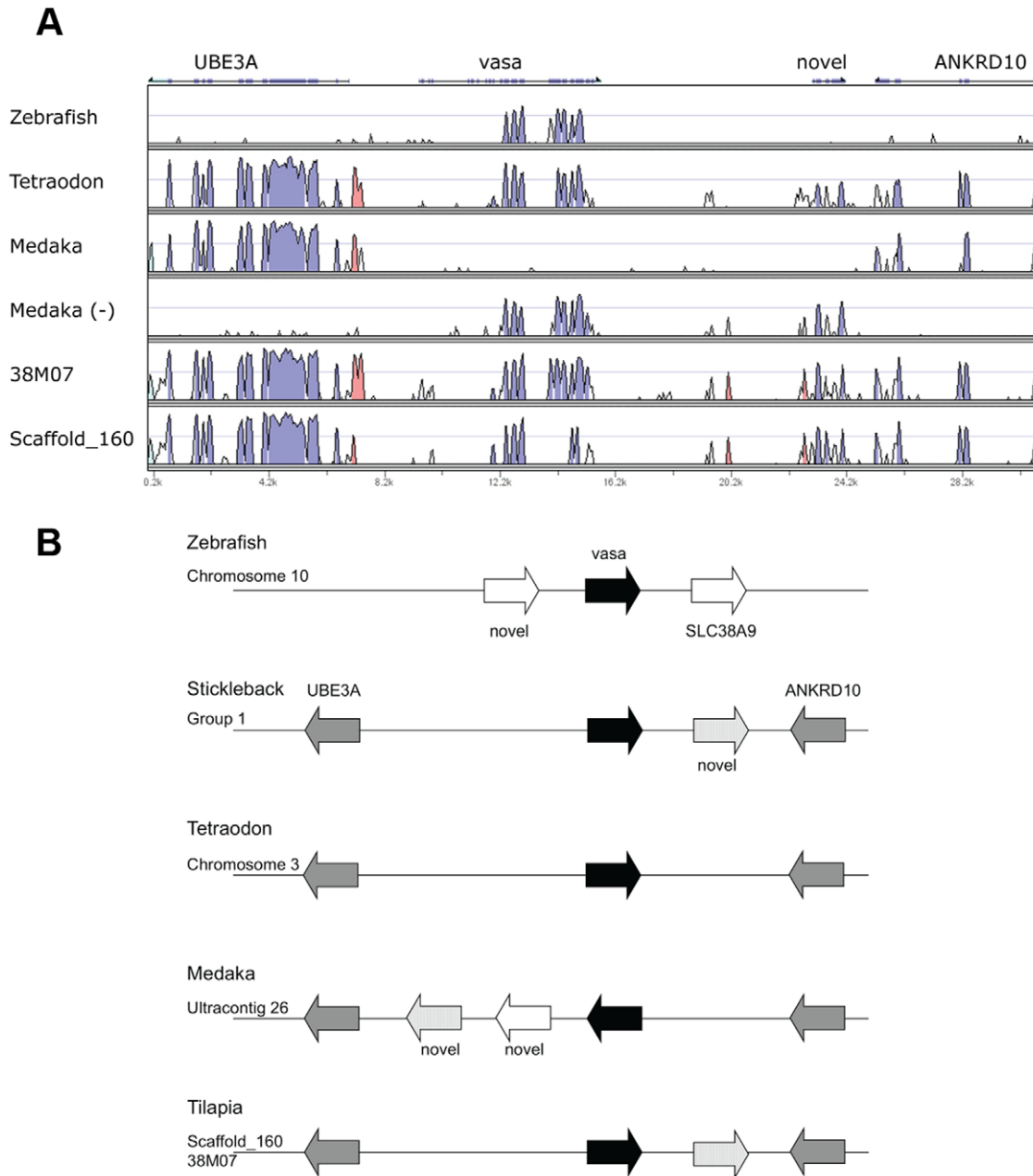

**Figure 2. BAC clone 38M07 corresponds to a region between the UBE3A and ANKR10 genes.** (A) VISTA plots against stickleback show that 38M07 and Scaffold\_160 cover a region between UBE3A and ANKR10 genes, in which the *vasa* gene is located in other teleosts. The complementary sequence of medaka (-) was also used because of a local inversion of *vasa* in the genome assembly. (B) Genomic organization around the *vasa* gene of zebrafish, stickleback, *Tetraodon*, medaka and tilapia. The genomic organization is conserved in other teleosts except for the distantly related zebrafish, the inversion in medaka, and some lineage-specific predicted novel genes. doi:10.1371/journal.pone.0029477.g002

13 (Tables S1, S2, S3). While the exons in clones 38M07 and 72C07 are in frame, the short exon 6 of 71H03 generates a stop codon in exon 7. Therefore, the *vasa* gene on clone 71H03 might be a pseudogene, or might produce the short splicing form, which skips exons 6 and 8 (see *Discussion*).

## Discussion

Taken together, these results suggest that the Nile tilapia have at least three copies of the *vasa* gene. The locus at the ancestral site has been duplicated to create two additional *vasa* genes located at

distant sites (Figure 6). Importantly, the duplicated loci retain the introns of the original locus, excluding the possibility that these duplicates were created by reverse transcription of a *vasa* mRNA. The duplicated loci also retain upstream regions of several kilobases from the putative transcriptional start sites of exon 1. Therefore they are likely to be functional for the regulation of gene expression. While the copy on BAC 72C07 was inserted into an intergenic region, the copy on BAC 71H03 was inserted into an existing novel gene locus. It is not known whether the insertion in 71H03 knocked out the existing gene function or produced a new hybrid gene product. Further studies are needed to determine

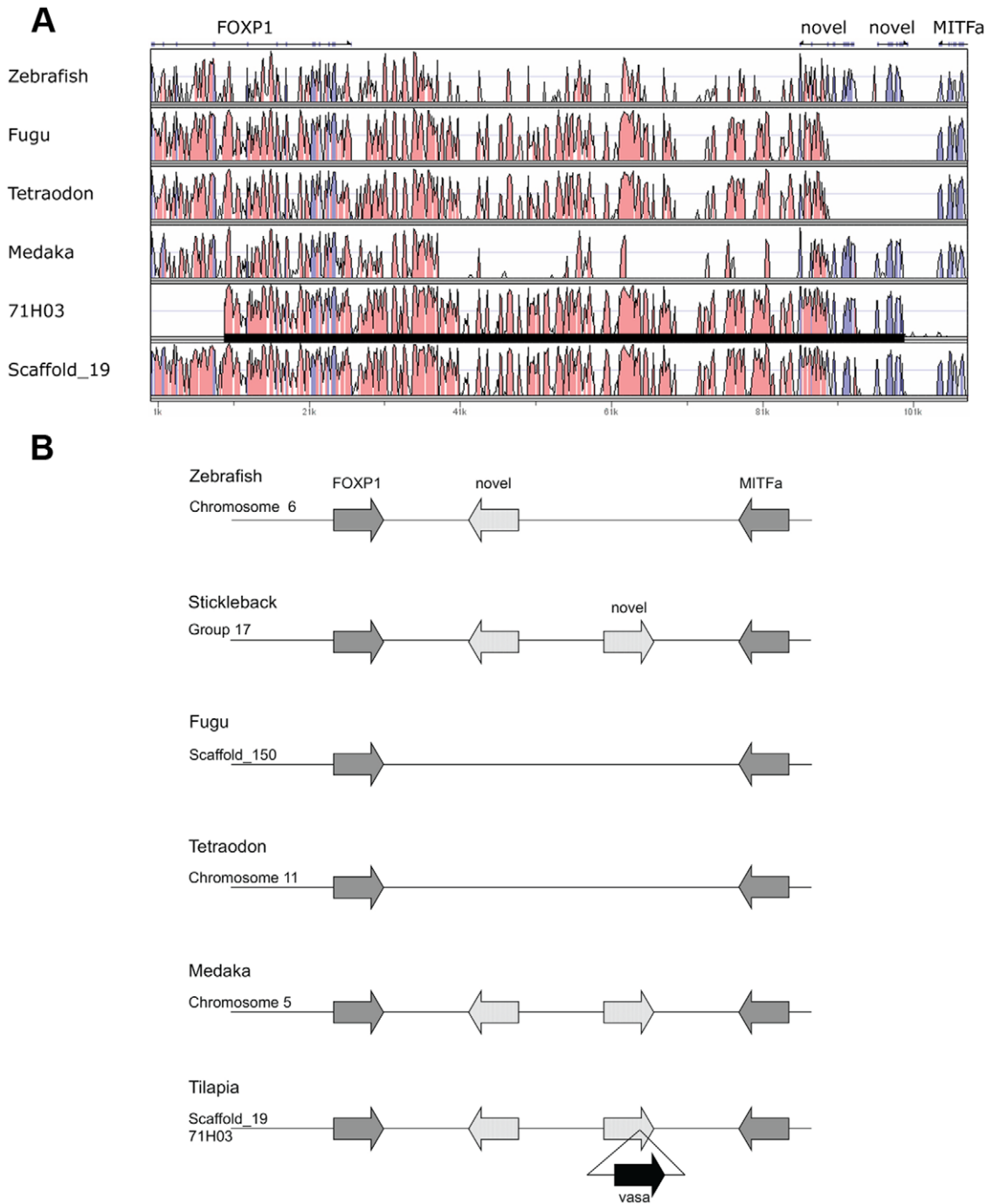
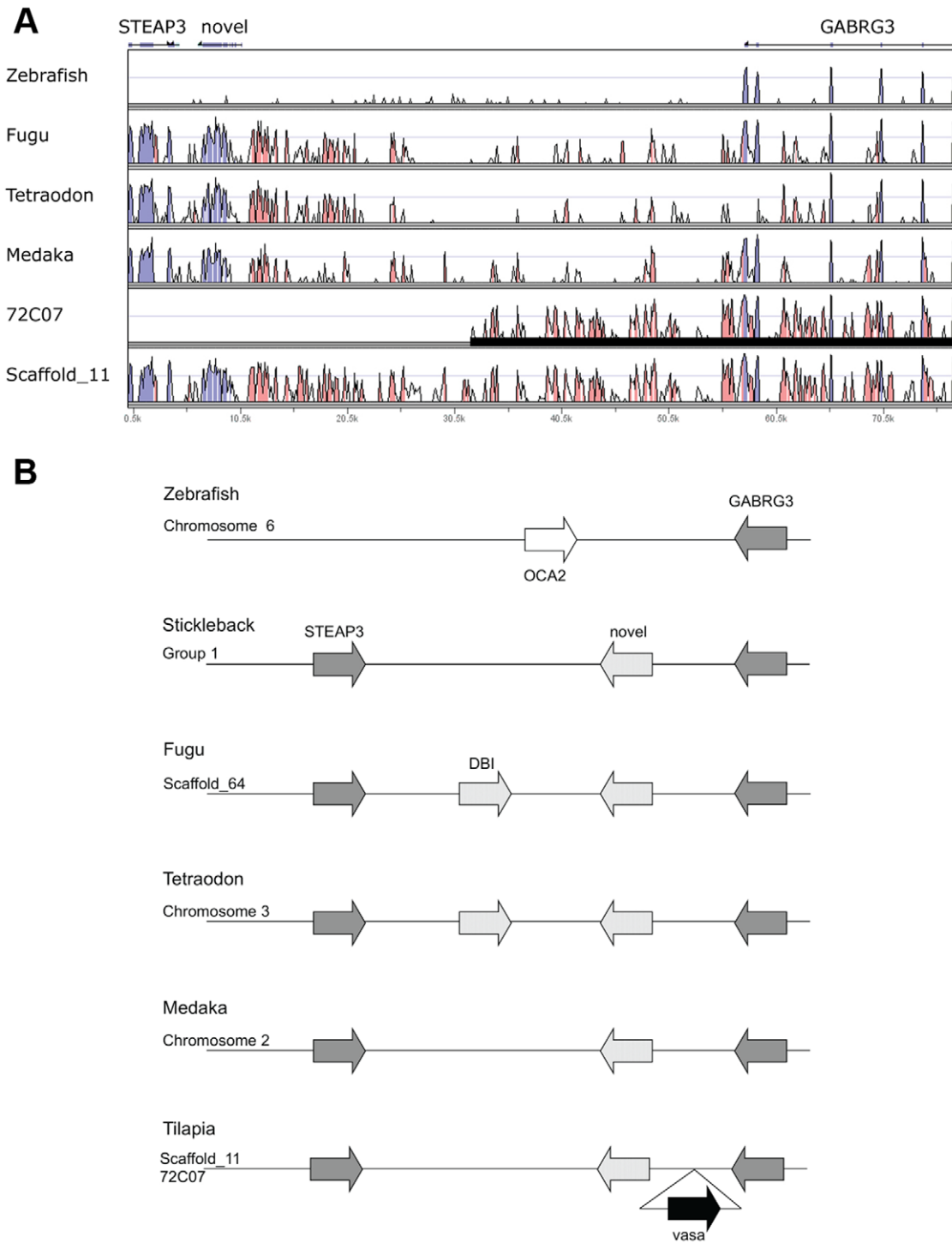

**Figure 3. BAC clone 71H03 corresponds to a region between the FOXP1 and MITFa genes.** (A) VISTA plots against stickleback show that 71H03 and Scaffold\_19 correspond to a region between the FOXP1 and MITFa genes. Black bar indicates the region covered by BAC clone 71H03. Note that a *vasa* gene is not located in this region of other teleosts. (B) Genomic organization between the FOXP1 and MITFa genes of zebrafish, stickleback, fugu, *Tetraodon*, medaka and tilapia. The genomic organization is conserved in teleosts, except that two novel genes are predicted to be lineage-specific. The *vasa* gene copy on 71H03 was integrated into one of these novel genes.  
doi:10.1371/journal.pone.0029477.g003

whether each *vasa* locus produces a functional gene and how these insertions have affected the expression of neighboring genes.

Kobayashi et al. [30] reported that Nile tilapia have two isoforms of the *vasa* gene. The short form (Vas-s) was identical with the normal one (Vas) except that it lacked two small portions of the N-terminal regions, which were predicted as exons 6 and 8 in this study (Table S4). We found that the exons on clones

38M07 and 72C07 are in frame throughout the coding region. Therefore, *vasa* genes on clones 38M07 and 72C07 could be functional. On the other hand, the short exon 6 of clone 71H03 generates a stop codon in exon 7. However, if the exons 6 and 8 of clone 71H03 were skipped like Vas-s, then the short exons could be in frame. Therefore, we could not determine whether 71H03 is a pseudogene, or produces the short splicing form.



**Figure 4. BAC clone 72C07 corresponds to a region between the STEAP3 and GABRG3 genes.** (A) VISTA plots against stickleback show that 72C07 and Scaffold\_11 correspond to a region between the STEAP3 and GABRG3 genes. Black bar indicates the region covered by BAC clone 72C07. Note that a *vasa* gene is not located in this region of other teleosts. (B) Genomic organization between the STEAP3 and GABRG3 genes of zebrafish, stickleback, fugu, *Tetraodon*, medaka and tilapia. The genomic organization is found conserved in other teleosts, except in the distantly related zebrafish and that the DBI gene is found to be lineage-specific. The *vasa* gene copy on 72C07 was inserted into the intergenic region between a novel gene and GABRG3.

doi:10.1371/journal.pone.0029477.g004

Further studies are needed to determine how the splicing isoforms are generated.

Most chordates have a single copy of the *vasa* gene, although alternative splicing forms have been characterized in some species

(e.g. zebrafish [33]). A dominant feature of fish genomes is the whole genome duplication that occurred at the origin of teleost fish [34], followed by lineage-specific gains and losses of individual genes [35]. Sequence polymorphisms in *vasa* likely arising from

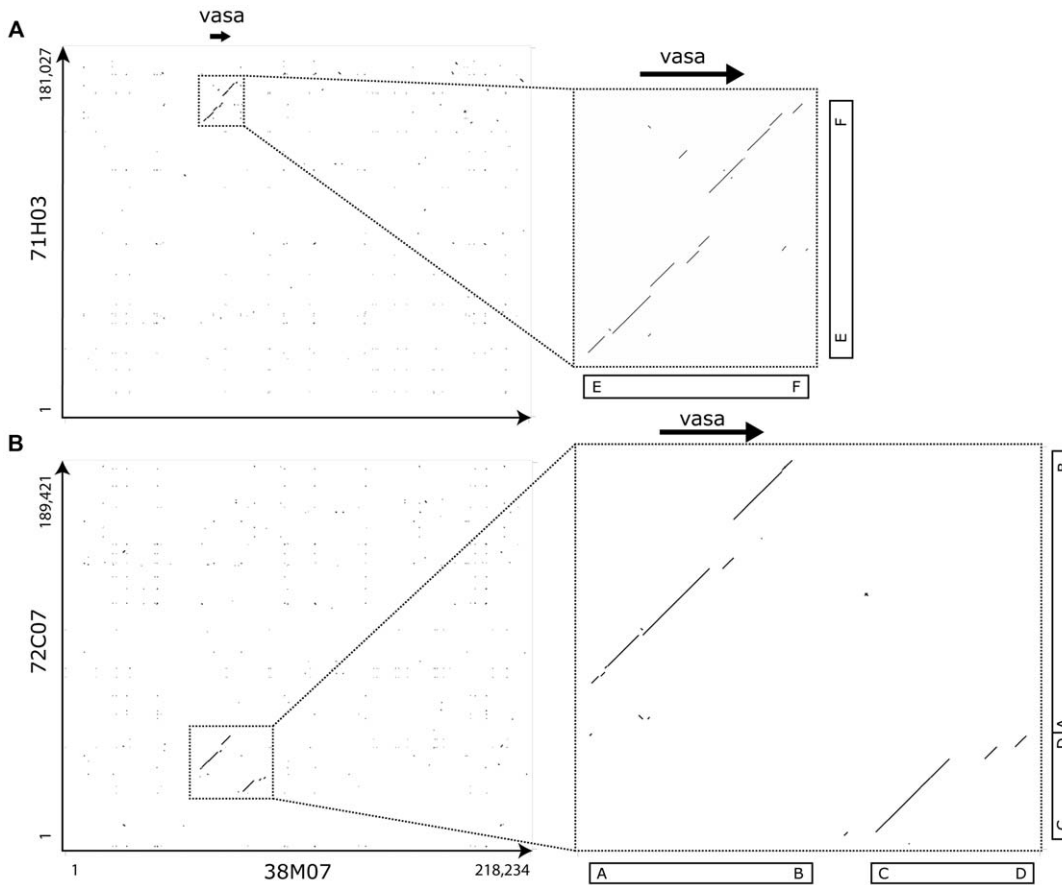

**Figure 5. Only the *vasa* gene locus was duplicated in 71H03 and 72C07.** (Left) Dotplots of 38M07 contigs against (A) 71H03 contigs and (B) 72C07 contigs. (Right) Magnification of the regions. Black arrow indicates the coding region of *vasa* gene. Boxes A–B and E–F show that only the *vasa* gene locus of 38M07 was duplicated into loci of 72C07 and 71H03, respectively. In addition, box C–D shows a difference in order in which the downstream region of the 38M07 *vasa* gene locus is duplicated into the upstream region of the 72C07 *vasa* gene locus. The boxes A–B, C–D and E–F correspond to those of Figures 7, 8, S3, S4 and S5. doi:10.1371/journal.pone.0029477.g005

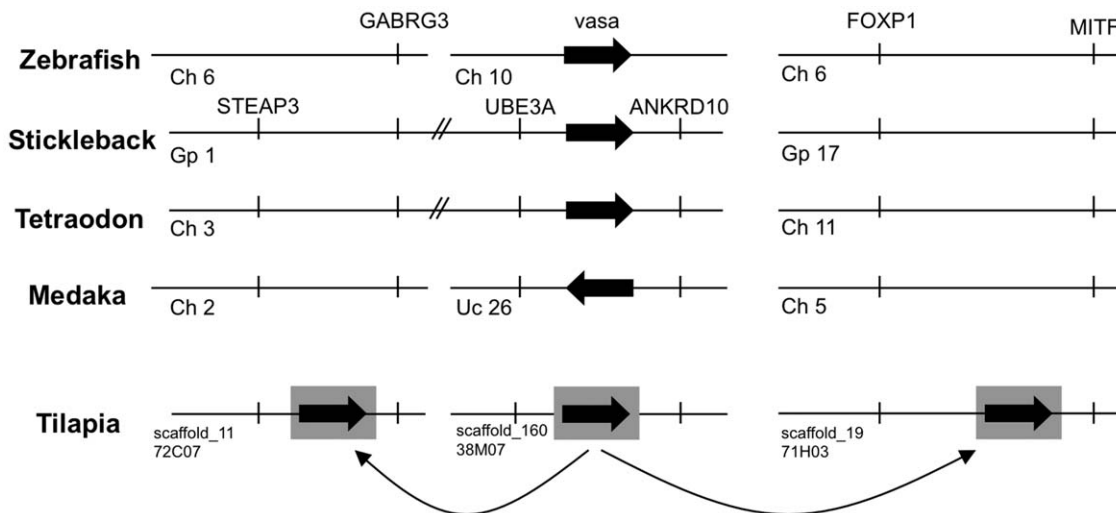

**Figure 6. Nile tilapia has one ancestral and two recent duplicate *vasa* loci.** This study reveals that Nile tilapia has at least three *vasa* loci with one original and two extra loci for *vasa* gene. In these duplications, only a small region encompassing the *vasa* gene was duplicated from the original site and integrated into novel sites. doi:10.1371/journal.pone.0029477.g006

gene duplicates have been characterized in goldfish *Carassius auratus* (Accession Numbers: AY821683, AY821684) and swamp eel *Monopterus albus* (AY912131, DQ174775). Therefore, it is likely that lineage-specific duplication of *vasa* gene has occurred several times during the evolution of teleosts. Draft genome assemblies of four East African cichlids closely related to tilapia (i.e. *Astatotilapia burtoni*, *Metriaclima zebra*, *Pundamilia nyererei* and *Neolamprologus brichardi*) have only one copy of the *vasa* gene (Figure S3). The divergence time between tilapia and the East African cichlids is estimated at 10 million year [17]. The synonymous substitution rate of 38M07-71H03 and 38M07-72C07 were calculated at 0.0152 and 0.0170, respectively. If the synonymous substitution rate per year is assumed to be  $5.5 \times 10^{-9}$  [36], the time of divergence between 38M07-71H03 and between 38M07-72C07 would be estimated at 2.76 and 3.09 million year, respectively. Therefore, the duplications of the *vasa* gene we have characterized in Nile tilapia might have occurred twice during the recent evolution of the genus *Oreochromis*: the duplication of 72C07 was first, and 71H03 second.

We found that Nile tilapia has undergone duplication of the *vasa* gene by an unusual mechanism, in which a large fragment encompassing the coding region was duplicated from the original site and integrated in novel sites. Retention of the ancestral exon-intron structure in the duplicated loci indicates the duplication was via a DNA intermediate, not by reverse transcription of an mRNA. The structure of the insertion in 72C07 suggests a circular intermediate in the duplication. Circular DNA intermediates have been recognized recently as a new mechanism to explain eukaryotic gene duplication. Borneman et al. [37] characterized the genome of industrial strains of yeast *Saccharomyces cerevisiae*, and found a cluster of five ORFs have integrated into the genomes at multiple points via circular DNA intermediates, whose length is estimated to be around 15 kb. Durkin et al. [38] also found a

segment of the *KIT* gene that is involved in coloring animal coats, was duplicated via circular DNA intermediates, whose length is estimated to be less than 480 kb, and concluded that it would cause coat color changes in some breeds of cattle.

The difference in sequence order between clones 38M07 and 72C07 can be explained by this new mechanism. We believe that the duplication of at least the 72C07 *vasa* gene occurred via a circular DNA intermediate, whose length was about 28 kb (Figure 7). Since B–C region was not found in the *vasa* gene loci of the East African cichlids (dot-lined box in Figure S3), we speculated that the B–C region was inserted into 38M07 sometime between the duplication of 72C07 and 71H03. Several copies of the 6 bp motif GCAAAC were found around B, and might be involved in the insertion of B–C region (Figure S4).

Eichler et al. [39] found the motif CAGGG near the breakpoints in duplicated human loci, and speculated that the motif would be evidence for duplication model by circular DNA intermediate. We could not find any similar motifs in the sequences of the duplication boundaries (Figure 8 and Figure S4). However, an 8 bp inverted repeat was found in sites A and D of 38M07 (Figure 8A). We speculate that this 8 bp sequence was involved in generating circular DNA intermediates during the duplication.

We do not know whether the *vasa* gene in clone 71H03 was duplicated via a circular intermediate, because the signature inversion of sequence order was not found. We found a fragment of *Expander* (also known as *Rex3* [40]) at the starting sites of 38M07 and 71H03 (red in Figures 8B, also Figure S5), and it could be speculated that this LINE mediated the duplication of 71H03 *vasa* gene locus.

Our study has discovered evidence for two different mechanisms that might play an important role in lineage specific gene duplication in fishes. Further, we have characterized the

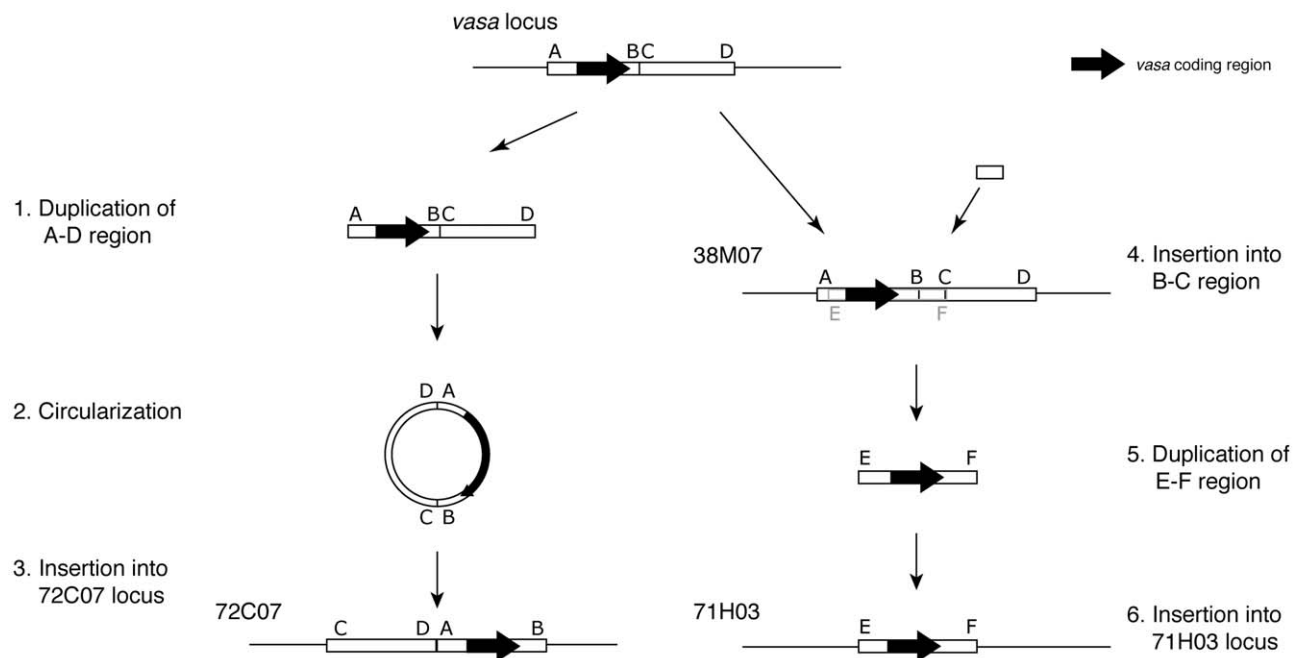

**Figure 7. A model for the duplication of a Nile tilapia *vasa* gene.** Duplications of the *vasa* gene occurred twice during the recent evolution of the genus *Oreochromis*. We speculated that the B–C region was inserted into 38M07 shortly after the duplication of 72C07. A circular DNA intermediate, which is recently recognized as a new mechanism to explain gene duplication, can explain the generation of a novel arrangement on clone 72C07. On the other hand, we have no evidence that the *vasa* gene in clone 71H03 was duplicated via a circular intermediate. Black arrow indicates the coding region of *vasa* gene. Boxes A–B, C–D, and E–F correspond to those of Figures 5, 8, S3, S4 and S5. doi:10.1371/journal.pone.0029477.g007



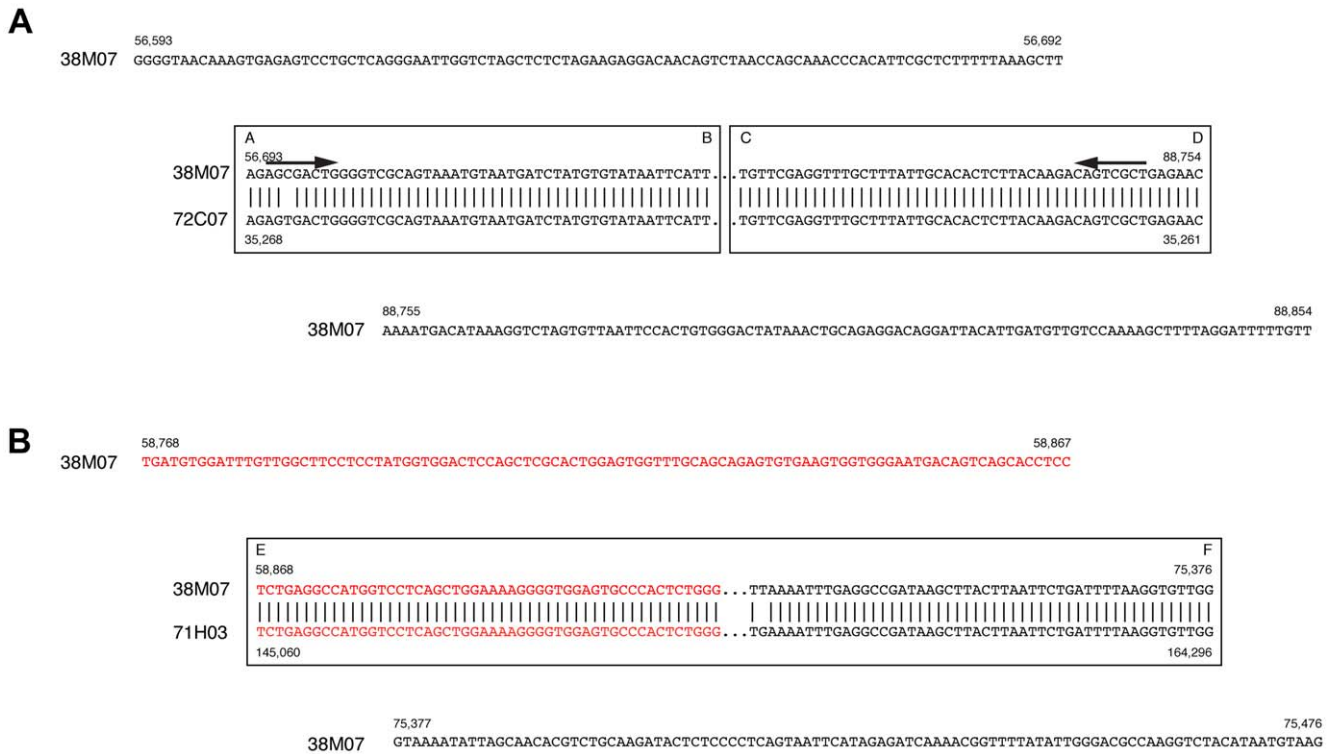

**Figure 8. Sequences of the duplication boundaries.** (A) 100 bp of 38M07 sequences flanking the left side of Box A–B and the right side of Box C–D. Black arrows indicate an 8 bp inverted repeat at sites A and D. (B) 100 bp of 38M07 sequences flanking Box E–F. Red letters indicate an *Expander* LINE, shown in Figure S5. Boxes A–B, C–D, and E–F correspond to those of Figures 5, 7, S3, S4 and S5. doi:10.1371/journal.pone.0029477.g008

regulatory regions flanking all three copies of the *vasa* gene in the Nile tilapia genome, which will allow the design of transgenic constructs for specific expression of genes in the developing gonad.

## Materials and Methods

### Screening, sequencing, and analysis of Nile tilapia BAC clones

To determine the genomic sequence of the Nile tilapia *vasa* genes, we screened a BAC library derived from sperm of the Lake Manzallah strain of *O. niloticus* [31]. We performed a PCR-based BAC library screening [32], using primers *vasaF* (5′-GGC AAA TGT TCT GTC CTG GT -3′) and *vasaR* (5′-CAC TGT CAG CTC CTG GAT CA -3′), designed using tilapia cDNA sequence data and targeting an exon that is highly conserved among teleosts. Overlapping BACs were identified from the contigs assembled from restriction fingerprint data [32]. Selected BAC clones were cultured and prepared using the PSI Clone Big BAC DNA kit (Princeton Separations, Freehold NJ, USA). Sequences of these clones were determined on a Roche 454 DNA sequencer (Branford CT, USA) and assembled using Newbler [41]. GenBank accession numbers of the assembled clones are AB649031-3.

Blast searches against the recently released tilapia genome assembly (GenBank accession #PRJNA59571) were done using the bioinformatic resources of BouillaBase.org (<http://cichlid.umd.edu/blast/bblast.html>). Alignments of the BAC clones to the genomic sequences were constructed with PipMaker [42].

### Genomic structure for three loci of *vasa* gene

The genomic information for teleost *vasa* regions was downloaded from Ensembl (<http://www.ensembl.org>). To construct Figure 2,

we analyzed the region 6,543,795–6,575,246 bp on chromosome 10 of zebrafish (*Zv9*), the region 26,979,595–27,010,559 bp on group 1 of stickleback (*BROADS1*), the region 7,504,473–7,530,546 bp on chromosome 3 of *Tetraodon*, (*TETRAODON8*), and the region 15,196–58,492 bp on ultracontig 26 of medaka, (*MEDAKA1*). The genomic data of *Takifugu* (*FUGU4*) has not been assembled between ENSTRUG00000006601 on scaffold\_284 and ENSTRUG00000002557 on scaffold\_151, so it was not included in our analysis. For Figure 3, we analyzed the region 47,919,490–47,463,463 bp on chromosome 6 of zebrafish, 13,964,270–14,072,374 bp on stickleback group 17; 516,574–618,053 bp on scaffold\_150 of *fugu*; 10,990,779–11,069,617 bp on chromosome 11 of *Tetraodon* and 4,992,801–5,209,014 bp on chromosome 5 of medaka. For Figure 4, we compared the region 37,813,999–38,288,577 bp on zebrafish chromosome 6, 23,562,074–23,639,703 bp on stickleback group 1, 835,659–940,881 bp on *Takifugu* scaffold\_64, 4,433,359–4,514,716 bp on *Tetraodon* chromosome 3 and 24,776,513–24,977,787 bp on medaka chromosome 2. We used VISTA ([43], AVID alignment method, unmasked sequences) to align and visualize the genomic sequences. For Figure S5, repetitive elements of tilapia genome were identified with RepeatModeler (<http://www.repeatmasker.org/RepeatModeler.html>).

## Supporting Information

**Figure S1 Comparison of BAC sequence contigs with the Broad genome assembly.** Dotplots of the BAC sequence contigs against equivalent genomic scaffolds. (A) Orientation of 11 contigs for 38M07 against genomic scaffold\_160. (B) 5 contigs of 71H03 against scaffold\_19. (C) 3 contigs of 72C07 against



scaffold\_11. Note that regions containing *vasa* gene sequences (arrow) are poorly matched. (TIF)

**Figure S2 Comparison of *vasa* mRNA sequences to the BACs and genome scaffolds.** (A) Dotplots of the *vasa* mRNA sequence (Genbank accession #AB032467 [29]) versus BAC 38M07 and genome scaffold\_160. (B) *vasa* mRNA versus BAC 71H03 and genome scaffold\_19. (C) *vasa* mRNA versus BAC 72C07 and genome scaffold\_11. Note that all of the exons can be predicted in the comparisons of the mRNA to the BAC sequences, but that not all of the exons are predicted from the genome scaffolds. (TIF)

**Figure S3 Comparison of Nile tilapia 38M07 with draft genome assemblies of four East African cichlids.** (A) *Neolamprologus brichardi*, (B) *Astatotilapia burtoni*, (C) *Metriaclima zebra*, (D) *Pundamilia nyererei*. Black arrow indicates the coding region of *vasa* gene. Boxes A–B and C–D correspond to those of Figures 5, 7, 8, S4 and S5. Dot-lined box indicates that the four cichlids are missing the B–C region and part of the C–D region. Black arrow indicates the coding region of *vasa* gene. (TIF)

**Figure S4 Sequences of the duplication boundaries.** (A) 100 bp of 71H03 sequence flanking Box E–F. Red and green letters indicate a LINE of *Expander* and a DNA transposon of Tc1-like respectively, as shown in Figure S5. (B) 100 bp of 72C07 sequences flanking the left side of Box C–D and the right side of Box A–B. (C) 100 bp of 38M07 and 71H03 sequences flanking Box B–C. Blue arrows indicate a 6 bp motif of GCAAAC. Boxes A–B, C–D and E–F correspond to those of Figures 5, 7, 8, S3 and S5. (TIF)

## References

- Nelson J (2006) Fishes of the world. Forth ed. Hoboken NJ, USA: John Wiley & Sons.
- Devlin RH, Nagahama Y (2002) Sex determination and sex differentiation in fish: an overview of genetic, physiological, and environmental influences. *Aquaculture* 208: 191–364.
- Food and Agriculture Organization (FAO) (2008) The State of World Fisheries and Aquaculture. Rome, Italy. Available: <http://www.fao.org/fishery/sofia/en>. Accessed 24 January 2011.
- McCormick SD, Hasegawa S, Hirano T (1992) Calcium uptake in the skin of a freshwater teleost. *Proc Natl Acad Sci USA* 89: 3635–3638.
- Farrell J, Campana SE (1996) Regulation of calcium and strontium deposition on the otoliths of juve Nile Tilapia, *Oreochromis niloticus*. *Comp Biochem Physiol A* 115: 103–109.
- Parhar IS, Soga T, Sakuma Y (2000) Thyroid hormone and estrogen regulate brain region-specific messenger ribonucleic acids encoding three gonadotropin-releasing hormone genes in sexually immature male fish, *Oreochromis niloticus*. *Endocrinol* 141: 1618–1626.
- Strüssmann CA, Nakamura M (2002) Morphology, endocrinology, and environmental modulation of gonadal sex differentiation in teleost fishes. *Fish Physiol Biochem* 26: 13–29.
- Majumdar KC, McAndrew BJ (1986) Relative DNA content of somatic nuclei and chromosomal studies in three genera, *Tilapia*, *Sarotherodon*, and *Oreochromis* of the tribe Tilapiini (Pisces, Cichlidae). *Genetica* 68: 175–188.
- Kocher TD, Lee WJ, Sobolewska H, Penman D, McAndrew B (1998) A genetic linkage map of a cichlid fish, the Tilapia (*Oreochromis niloticus*). *Genetics* 148: 1225–1232.
- Oliveira C, Wright JM (1998) Molecular cytogenetic analysis of heterochromatin in the chromosomes of tilapia, *Oreochromis niloticus* (Teleostei: Cichlidae). *Chromosome Res* 6: 205–211.
- Katagiri T, Kidd C, Tomasino E, Davis JT, Wishon C, et al. (2005) A BAC-based physical map of the Nile Tilapia genome. *BMC Genomics* 6: 89.
- Santini S, Bernardi G (2005) Organization and base composition of tilapia Hox genes: implications for the evolution of Hox clusters in fish. *Gene* 346: 51–61.
- Fujimura K, Okada N (2007) Development of the embryo, larva and early juvenile of Nile Tilapia *Oreochromis niloticus* (Pisces: Cichlidae). *Developmental staging system*. *Dev Growth Differ* 49: 301–324.
- Fujimura K, Okada N (2008) Bone development in the jaw of Nile Tilapia *Oreochromis niloticus* (Pisces: Cichlidae). *Dev Growth Differ* 50: 339–355.
- Fujimura K, Okada N (2008) Shaping of the lower jaw bone during growth of Nile Tilapia *Oreochromis niloticus* and a Lake Victoria cichlid *Haplochromis chilotes*: a geometric morphometric approach. *Dev Growth Differ* 50: 653–663.
- Fryer G, Iles T (1972) The Cichlid Fishes of the Great Lakes of Africa. Edinburgh: Oliver & Boyd.
- Kocher TD (2004) Adaptive evolution and explosive speciation: the cichlid fish model. *Nature Rev Genet* 5: 288–298.
- Cnaani A, Lee BY, Zilberman N, Ozouf-Costaz C, Hulata G, et al. (2008) Genetics of sex determination in tilapia species. *Sex Dev* 2: 43–54.
- Ser JR, Roberts RB, Kocher TD (2010) Multiple interacting loci control sex determination in lake Malawi cichlid fish. *Evolution* 64: 486–501.
- Ijiri S, Kaneko H, Kobayashi T, Wang DS, Sakai F, et al. (2008) Sexual Dimorphic Expression of Genes in Gonads During Early Differentiation of a Teleost Fish, the Nile Tilapia *Oreochromis niloticus*. *Biol Reprod* 78: 333–341.
- Fujimura K, Kocher TD (2011) *Tol2*-mediated transgenesis in tilapia (*Oreochromis niloticus*). *Aquaculture* 319: 342–346.
- Cordin O, Banroques J, Tanner NK, Linder P (2006) The DEAD-box protein family of RNA helicases. *Gene* 367: 17–37.
- Lasko PF, Ashburner M (1988) The product of the *Drosophila* gene *vasa* is very similar to eukaryotic initiation factor-4A. *Nature* 335: 611–617.
- Raz E (2000) The function and regulation of *vasa*-like genes in germ-cell development. *Genome Biol* 1: reviews1017.
- Krövel AV, Olsen LC (2002) Expression of a *vas:EGFP* transgene in primordial germ cells of the zebrafish. *Mech Dev* 116: 141–150.
- Yoshizaki G, Takeuchi Y, Sakatani S, Takeuchi T (2000) Germ cell-specific expression of green fluorescent protein in transgenic rainbow trout under control of the rainbow trout *vasa*-like gene promoter. *Int J Dev Biol* 44: 323–326.
- Tanaka M, Kinoshita M, Kobayashi D, Nagahama Y (2001) Establishment of medaka (*Oryzias latipes*) transgenic lines with the expression of green fluorescent protein fluorescence exclusively in germ cells: a useful model to monitor germ cells in a live vertebrate. *Proc Natl Acad Sci USA* 98: 2544–2549.
- Knaut H, Steinbeisser H, Schwarz H, Nüsslein-Volhard C (2002) An evolutionary conserved region in the *vasa* 3'UTR targets RNA translation to the germ cells in the zebrafish. *Curr Biol* 12: 454–466.
- Kobayashi T, Kajiura-Kobayashi H, Nagahama Y (2000) Differential expression of *vasa* homologue gene in the germ cells during oogenesis and spermatogenesis in a teleost fish, tilapia, *Oreochromis niloticus*. *Mech Dev* 99: 139–142.

**Figure S5 Repetitive elements around *vasa* gene loci.** Fragments of repetitive elements were shown as colored boxes for (A) 38M07, (B) 71H03 and (C) 72C07. Black arrow indicates the coding region of *vasa* gene. Boxes A–B, C–D and E–F correspond to those of Figures 5, 7, 8, S3 and S4. Fragments of the long interspersed element (LINE) *Expander* (also known as *Rex3*) were found at the breakpoints in 38M07 and 71H03. (TIF)

**Table S1 Predicted exons of 38M07 *vasa* gene.** (XLS)

**Table S2 Predicted exons of 71H03 *vasa* gene.** (XLS)

**Table S3 Predicted exons of 72C07 *vasa* gene.** (XLS)

**Table S4 Predicted exons of mRNA sequences, which are deposited on GenBank.** (XLS)

## Acknowledgments

We thank Dr. Chinnappa Kodira (454 Life Sciences) for sequencing the BAC clones. Dr. Karen Carleton provided helpful comments on the manuscript.

## Author Contributions

Conceived and designed the experiments: KF TDK. Performed the experiments: KF. Analyzed the data: KF MAC. Wrote the paper: KF TDK.

30. Kobayashi T, Kajiura-Kobayashi H, Nagahama Y (2002) Two isoforms of *vasa* homologs in a teleost fish: their differential expression during germ cell differentiation. *Mech Dev* 111: 167–171.
31. Katagiri T, Asakawa S, Minagawa S, Shimizu N, Hirono I, et al. (2001) Construction and characterization of BAC libraries for three fish species; rainbow trout, carp and tilapia. *Animal Genet* 32: 200–204.
32. Katagiri T, Kidd C, Tomasino E, Davis JT, Wishon C, et al. (2005) A BAC-based physical map of the Nile Tilapia genome. *BMC Genomics* 6: 89.
33. Bártfai R, Orbán L (2003) The *vasa* locus in zebrafish: multiple RGG boxes from duplications. *DNA Cell Biol* 22: 47–54.
34. Meyer A, Schartl M (1999) Gene and genome duplications in vertebrates: the one-to-four (-to-eight in fish) rule and the evolution of novel gene functions. *Curr Opin Cell Biol* 11: 699–704.
35. Robinson-Rechavi M, Marchand O, Escriva H, Laudet V (2001) An ancestral whole-genome duplication may not have been responsible for the abundance of duplicated fish genes. *Curr Biol* 11: R458–459.
36. Hayashida H, Miyata T (1983) Unusual evolutionary conservation and frequent DNA segment exchange in class I genes of the major histocompatibility complex. *Proc Natl Acad Sci USA* 80: 2671–2675.
37. Borneman AR, Desany BA, Riches D, Affourtit JP, Forgan AH, et al. (2011) Whole-Genome Comparison Reveals Novel Genetic Elements That Characterize the Genome of Industrial Strains of *Saccharomyces cerevisiae*. *PLoS Genet* 7: e1001287.
38. Durkin K, Cambisano N, Ariz N, Fasquelle C, Karim L, et al. (2011) Molecular dissection of the color-sided phenotype in cattle reveals a novel mechanism of chromosome evolution involving circular shuttling intermediates. *Chromosome Res* 19: S18.
39. Eicher EE, Lu F, Shen Y, Antonacci R, Jurecic V, et al. (1996) Duplication of a gene-rich cluster between 16p11.1 and Xq28: a novel pericentromeric-directed mechanism for paralogous genome evolution. *Human Mol Genet* 5: 899–912.
40. Volff JN, Körtting C, Sweeney K, Schartl M (1999) The Non-LTR Retrotransposon *Rex3* from the Fish *Xiphophorus* is Widespread Among Teleosts. *Mol Biol Evol* 16: 1427–1438.
41. Margulies M, Egholm M, Altman WE, Attiya S, Bader JS, et al. (2005) Genome sequencing in microfabricated high-density picolitre reactors. *Nature* 437: 376–380.
42. Schwartz S, Zhang Z, Frazer KA, Smit A, Riem C, et al. (2000) PipMaker—A Web Server for Aligning Two Genomic DNA Sequences. *Genome Res* 10: 577–586.
43. Frazer KA, Pachter L, Poliakov A, Rubin EM, Dubchak I (2004) VISTA: computational tools for comparative genomics. *Nucleic Acids Res* 32: W273–279.