



Since January 2020 Elsevier has created a COVID-19 resource centre with free information in English and Mandarin on the novel coronavirus COVID-19. The COVID-19 resource centre is hosted on Elsevier Connect, the company's public news and information website.

Elsevier hereby grants permission to make all its COVID-19-related research that is available on the COVID-19 resource centre - including this research content - immediately available in PubMed Central and other publicly funded repositories, such as the WHO COVID database with rights for unrestricted research re-use and analyses in any form or by any means with acknowledgement of the original source. These permissions are granted for free by Elsevier for as long as the COVID-19 resource centre remains active.

Molecular Detection of Multiple Respiratory Viruses

Jeanne Carr, Donna G. Williams and Randall T. Hayden
St. Jude Children's Research Hospital, Memphis, TN

INTRODUCTION AND DEFINITIONS

Respiratory infections are the most common human illnesses worldwide. Clinical manifestations of these infections vary from a mild, self-limiting upper respiratory tract infection (URI), the common cold, to acute respiratory tract infection (ARI). Acute lower respiratory tract infections (pneumonia, bronchitis, and bronchiolitis) result in 20% of all deaths in children under the age of 5 years, with pneumonia being the most frequent cause of death (90%) (Kuhn, 2008). Seventy-five percent of all acute illnesses in developed countries are the result of ARIs, approximately 80% of which are viral in origin (Mahoney, 2008).

Adults may average two ARIs per year, while young children may experience five to seven viral respiratory infections per year (*Encyclopedia of Public Health*, 2009). The emergence of viral respiratory pathogens, such as influenza A viruses (H5N1, H1N1 swine-origin) and the human coronavirus (CoV) SARS-CoV, which causes severe acute respiratory syndrome, has brought new focus on the virology laboratory's role in clinical diagnosis. Timely reporting of viral respiratory infections may assist in selection of the most appropriate therapy (when available) and may also help reduce unnecessary use of antibacterial agents. Improved diagnostics can also play an important role in infection control, both within individual institutions and more broadly in helping to identify pathogens and prevent spread within and among geographic regions.

Numerous diagnostic technologies have been used in these efforts. Antibody detection is often of limited use as most serologic assays rely on the comparison of acute and convalescent sera, preventing rapid diagnosis. Rapid enzyme immunoassays (EIA) are commercially available for influenza A, influenza B, and respiratory syncytial virus (RSV). These tests are primarily used at outpatient sites

and emergency departments due to their rapid turn-around time; however, they suffer from limitations in sensitivity and specificity. Over the past few decades, diagnosis of the most common respiratory viruses has typically involved the direct examination of respiratory specimens using fluorescent antibodies (FA) and the inoculation of those samples into various cell lines growing in tubes and more recently in shell vials. Tube cultures allow one to observe the cell layers over a period of several days or weeks for cytopathic effect (CPE), reflecting viral growth. Many common respiratory viral pathogens exhibit typical CPE patterns, allowing presumptive identification. Confirmation of viral identity may be made using FA staining of the cell layer. Sometimes ancillary tests, such as hemadsorption, are necessary for detection and identification. Shell vial cultures (SVC) can allow much more rapid detection. SVCs are made up of dram vials containing a coverslip with a monolayer of cells covered by culture medium. Respiratory samples are inoculated into the vial, which is then centrifuged to hasten viral attachment to the cell layer. Results from SVCs are usually available in 1 to 2 days. FA is even faster (3–18 hours) but suffers from a loss in sensitivity compared to culture-based methods. These techniques are all quite labor-intensive and require highly trained staff to perform. Tube culture methods remain the most sensitive, but even with prolonged incubation they may miss many infections.

Molecular techniques, most commonly exemplified by the polymerase chain reaction (PCR) and its variants (such as real-time PCR and reverse transcriptase [RT]-PCR), provide the opportunity for vastly improved sensitivity over conventional methods (Mahoney, 2008). Other amplification methods will be presented, such as isothermal methods of nucleic acid sequence-based amplification (NASBA) and loop-mediated isothermal amplification (LAMP). The potential advantages

of these methods come with significant challenges, however, as there may be a need for effective simultaneous detection of an increasingly broad spectrum of respiratory viral pathogens. If one is looking to replace FA and culture, this equates to a minimum of seven or eight individual PCR tests. Adding in newly described agents of potential clinical significance increases this number to between 15 and 20. The challenge of developing, validating, and implementing such a broad array of simultaneous molecular tests is great, and the cost may well be prohibitive.

The challenge has been met by designing PCR reactions to amplify and detect more than one viral target simultaneously (multiplexed PCR). Again, this apparent solution creates another set of challenges. As the number of reactants (primers, probes, targets, and internal controls) in a multiplex reaction increases, it becomes more difficult to optimize the assay and maintain sensitivity and specificity. Technical boundaries are also present. The number of individual targets that can be detected in a single reaction is limited by the number of reporter molecules that can be distinguished by detection instrumentation. To adapt for this limitation, many laboratory-developed assays (LDAs) for respiratory viruses consist of a series of PCR reactions. The series may be composed of three or four separate PCR assays, each having two or three targets per reaction vessel. Another approach may be the use of newer technologies to broaden the number of targets that may be detected following end-point amplification. Some of these methods will be discussed in the following sections.

SPECIMEN COLLECTION

Accurate detection of respiratory viruses depends on collection of high-quality specimens, with appropriate transport and storage of specimens prior to laboratory testing. Although the duration of viral shedding depends on the type of virus as well as the type of infection and age of the patient, as a rule specimens should be collected early in the acute phase of infection, ideally during the first 3 days after the onset of clinical symptoms, to maximize sensitivity.

In general, respiratory specimens for molecular testing are collected and handled in the same manner as those for viral culture and FA testing. Specimens for diagnosis of upper respiratory virus infections include nasopharyngeal aspirates or nasopharyngeal washes, nasopharyngeal swabs, and throat swabs. For the collection of swab specimens, commercially available swabs made of rayon, Dacron, polyester, and nylon are acceptable for use. Calcium alginate-tipped swabs are toxic to some viruses, and swabs with wooden handles can contain toxins and formaldehydes that may inhibit the detection of viruses. Recently, flocked swabs (Abu-Diab et al., 2008; Chan et al., 2008) have been

used for the collection of large numbers of epithelial cells from the lining of the nasopharynx. The flocked swab tips are made with perpendicular nylon fibers that act like a soft brush to dislodge epithelial cells. Several commercially available media are suitable for the transport of respiratory samples. Transport medium is necessary to prevent drying of the sample, to maintain viability of the virus, and to inhibit the growth of microbial contaminants. While viral transport media, such as M4 (Remel, Lenexa, KS), require transport at 4°C, transport media have become available that allow room-temperature storage prior to use as well as transport for up to 24 hours after specimen collection—for example, M4-RT (Remel, Lenexa, KS) and universal transport medium room temperature (UTM-RT) (Copan, Italia, Brescia, Italy) (Barger et al., 2005).

Nasopharyngeal aspirates or washes have historically been considered the preferred specimens for the detection of respiratory viruses, followed by nasopharyngeal swabs. A large number of respiratory epithelial cells can be obtained by proper collection of nasopharyngeal washes and aspirates, and this method is recommended for hospitalized patients, where an accurate diagnosis is critical for appropriate antiviral therapy and infection control measures. The detection of RSV, in particular, has been shown to improve with the collection of washes and aspirates rather than swabs (Sung et al., 2008). Recent studies in children have suggested that the use of flocked swabs transported in a viral transport medium provides an increase in specimen quality over other collection swabs with comparable sensitivity to nasopharyngeal aspirates (Abu-Diab et al., 2008; Chan et al., 2008). Walsh et al. (2008) showed there was no significant difference in sensitivity between nasopharyngeal aspirates transported in a viral transport medium and nasopharyngeal samples on flocked swabs in viral transport media. The less invasive flocked swab specimens would be an attractive alternative to nasopharyngeal aspirates, particularly in outpatient settings. Throat swabs are not a recommended specimen for molecular testing. However, molecular techniques have shown increased sensitivity in this specimen type over that seen with culture and antigen detection (Fiebelkorn and Nolte, 2004).

Specimens for the diagnosis of lower respiratory virus infections include bronchoalveolar lavage, tracheal aspirate, pleural fluid, and lung biopsy. Small biopsy tissue specimens should be placed in a suitable transport medium to prevent drying. In a hospital setting, where specimens will be processed promptly by the laboratory, large tissues and fluids may be submitted without the addition of transport medium. Although sputum is relatively easy to obtain and is often submitted to the laboratory for detection of lower respiratory tract infections, viruses detected in sputum may actually originate in the oropharynx. In addition, the mucus present in sputum may contain inhibitors that decrease the sensitivity of the molecular testing.

The best specimen for laboratory examination depends on the clinical setting of the patient as well as the site of infection, clinical suspicion of URI versus LRI, and laboratory methods of analysis to be used. Clinical suspicion of a particular viral pathogen may also affect this choice. For example, for optimal detection of the SARS CoV, sampling of the upper respiratory tract is insensitive for viral detection during the first week of disease. CoV viral loads are greater in the lower respiratory tract during this early period of infection, but collection of these types of samples may create aerosols, which can be dangerous to medical staff. According to the Centers for Disease Control and Prevention (CDC), during the first week of infection, nasopharyngeal and oropharyngeal specimens and plasma/serum should all be tested. Subsequently, nasopharyngeal and oropharyngeal specimens and stool can be used (Mahoney and Richardson, 2005).

ANALYTICAL TECHNIQUES

After proper specimen collection and transport, the major steps in a molecular assay can be divided into nucleic acid extraction, amplification, and detection. Each of these has to be examined for its contribution to the final outcome of the assay, and each is discussed separately in this chapter. Because several commercial extraction methods are available and relatively easy to perform, amplification and detection will typically require the most time and attention for optimization. Purified viral targets may be used for initial work to optimize amplification and detection steps. However, true clinical respiratory samples should also be processed in order to evaluate matrix effects on the extraction method and assay performance. An internal or external control (DNA or RNA, as appropriate) should be added to the clinical sample prior to extraction. This control gives one confidence that the patient sample has been handled appropriately throughout the assay and that reactants in the master mix are capable of producing amplicons.

Nucleic acid amplification tests (NAATs) are typically more sensitive than conventional methods (i.e., culture, immunofluorescence) for the detection of viral respiratory pathogens (Mahoney, 2008). Some of the most common amplification chemistries, such as PCR and RT-PCR, require instrumentation to cycle between temperatures for each step in the amplification process. Other methods, such as NASBA and LAMP are isothermal, eliminating the requirement for different temperatures during amplification.

Detection of amplification products may be end-point or real-time in nature. End-point determination is a single measurement taken after the amplification reaction has been completed. Real-time measurement of amplification products is performed concurrently with the amplification reaction. In the examples discussed throughout the chapter,

examples of both end-point and real-time measurements are presented. One should keep in mind that a significant advantage of real-time PCR is that amplification and detection can take place in an unopened tube, thereby reducing the risk of contamination and subsequent false-positive results. Some, but not all, end-point detection methods require post-amplification manipulation of PCR product. However, any time amplification tubes are opened and manual manipulation of amplicons occurs, as happens when loading an electrophoresis gel, there is a substantial risk of carryover contamination.

A discussion of NAATs with accompanying detection methods that have been used successfully in the detection of respiratory viruses follows. A host of different formats and chemistries are represented. Various assays target different numbers of viruses. Many are LDAs, and some use commercial reagents that are for research use only (RUO) or analyte-specific reagents (ASRs). Several commercial methods are also presented, including those currently cleared by the U.S. Food and Drug Administration (FDA) for in vitro diagnostic use.

Nucleic Acid Extraction

With the increased use of molecular techniques for identification of respiratory pathogens, the ability to isolate viral DNA and RNA from a variety of respiratory specimens has become increasingly important. Both DNA and RNA are degraded enzymatically by DNA- and RNA-specific nucleases (DNases and RNases), so proper handling of the sample is the first step for ensuring the isolation of high-quality nucleic acid. This is especially important when purifying RNA because of the inherent instability of the RNA molecule and the ubiquitous presence of RNases in the environment. The most common sources of RNase contamination are bacteria and molds, which can be introduced into the sample by contact with skin or contaminated laboratory surfaces. Gloves should be worn while handling samples and reagents, and all processing should be done using aseptic technique in a biological safety cabinet that is bleached and rinsed with alcohol before and after use. RNase-free reagents and plastic ware should be used. Unpreserved samples should be processed promptly upon receipt in the laboratory or frozen at -70°C (Walsh et al., 2008). The number of freeze-thaw cycles should be minimized for both specimens and solutions of extracted nucleic acid.

Historically, nucleic acid extraction has been accomplished by using time-consuming phenol-chloroform-based procedures followed by alcohol precipitation. Because of the number of manual steps as well as the hazardous chemicals involved, these procedures are of limited use in the clinical laboratory. In 1999, Boom and colleagues reported an extraction method based on reversible binding of nucleic

acid molecules onto silica in the presence of chaotropic salts (for example, guanidine thiocyanate). This method removes endogenous nucleases and PCR inhibitors and purifies nucleic acid from various types of clinical samples (Boom et al., 1999). Most commercially available extraction kits and automated extraction platforms are based on this method. Silica can be coated onto membrane filters or magnetic particles. Plastic columns containing silica-impregnated filters are one commonly adopted design. After an initial cell lysis and protein digestion step, the specimen is passed through the filter, which binds the nucleic acid, while residual proteins, polysaccharides, and other impurities present in the solution are removed by washing with buffers. Similar methods are based on the principle of adsorption of nucleic acid to silica-coated magnetic particles. After cell lysis and the addition of magnetic silica beads, the specimen is placed near a magnetic field. Nucleic acid is retained on the beads during the wash steps. Depending on the extraction protocol, the salt concentration and pH of the final wash buffer are adjusted to selectively elute DNA, RNA, or total nucleic acid (Qiagen, 1998). Ideally, an evaluation of the protocol should be performed for each virus and sample type that will be tested. Physical properties of the virus (for example, RNA vs. DNA, or enveloped vs. non-enveloped) as well as variations in the sample type, such as numbers of cells, viral load, and presence of mucus or other inhibitors must be considered when choosing an extraction protocol (Petrich et al., 2006).

A number of companies offer a range of automated nucleic acid extraction systems suitable for use by laboratories with high, medium, or low testing volumes. The smaller, less costly instruments have individually packaged reagent cartridges and can handle from 6 to 10 samples at a time with limited sample manipulation. The selection of automated extraction equipment requires consideration of a number of factors, including specimen type, input volume(s), elution volume(s), ease of operation, versatility, cost, throughput, and hands-on time for technologists.

Even with automated instrumentation, processing respiratory samples can be difficult due to the presence of mucus in samples such as nasopharyngeal aspirates, sputum, and bronchoalveolar lavages. Various methods have been compared, but to date there is no standardized pretreatment method for disrupting the mucus in these samples. Methods that have been proposed include protocols using N-acetylcysteine, or proteinase K (Qiagen, personal communication, 2009) and dithiothreitol (Sputasol) (Xiang et al., 2001). In molecular assays in which RNA targets alone are being assayed, pretreatment of the mucoid samples with DNase I has increased the rate of detection (Deiman et al., 2007). Because PCR-inhibiting substances in the mucus are often extracted along with the nucleic acid, it is important that some form of internal control be used during the extraction process.

Amplification and Detection

PCR

PCR and its variants represent by far the most common approach to both single-target and multiplexed assay design. This process exponentially amplifies DNA target sequences using DNA polymerase, deoxyribose nucleotides (dNTPs), and target-specific primers. The basic steps include (1) denaturation of input double-stranded DNA (dsDNA), (2) annealing of primers, and (3) elongation of primer sequences. These steps are then repeated for 30 to 50 cycles. RNA viral nucleic acid targets must first be reverse transcribed into complementary DNA (cDNA) before beginning the PCR process, a method commonly referred to as reverse transcription–polymerase chain reaction (RT-PCR). The PCR process is complex, and each constituent of the amplification reaction influences the efficiency and success of the outcome. Factors such as concentration of primers, template, dNTPs, and magnesium (Mg^{2+}), the type of polymerase used, template G + C content, and cycling parameters must all be balanced for optimal performance. Detection of the PCR products (amplicons) can be by size separation via gel electrophoresis or using hybridization with sequence-specific, reporter-labeled probes. The type of reporter molecule determines which detection instrumentation would be used for probe detection.

Nested PCR

Nested PCR is a modification of PCR that was designed to improve sensitivity and specificity. Nested PCR involves the use of two primer sets and two successive PCR reactions. The first set of primers are designed to anneal to sequences upstream from the second set of primers and are used in an initial PCR reaction. Amplicons resulting from the first PCR reaction are used as template for a second set of primers and a second amplification step. Sensitivity and specificity of DNA amplification may be significantly enhanced with this technique. However, the potential for carryover contamination of the reaction is typically also increased due to additional manipulation of amplicon products. To minimize carryover, different parts of the process should be physically separated from one another, preferably in entirely separate rooms. Amplicons from nested PCR assays are detected in the same manner as in PCR above.

Multiplexed PCR

The number of individual PCR reactions needed to detect the currently recognized spectrum of common viral respiratory pathogens would be approximately 20. A smaller number, perhaps 7 to 10, are generally regarded as having the most practical clinical importance, but the number may vary in

any given institution, depending on patient demographics, season, and geographic location. Monoplex PCR reactions for each of these viruses would be costly and labor-intensive. Multiplexed reactions have generated interest as a potential means of targeting a wide range of agents while maintaining practicality in terms of cost, ease of use, and throughput. While detection of all respiratory viruses in a single tube would be ideal, many LDAs seek three to five targets per reaction, reflecting limitations of optimization and instrumentation.

Multiplexed reactions require optimization of the same parameters as mentioned earlier for monoplex reactions. However, this work becomes more complex due to the requirement of maintaining sensitivity and specificity for multiple targets while using multiple primer pairs and probes. Optimal annealing temperatures for monoplex primer sets may significantly differ, resulting in potentially unequal amplification of the target sequences and competitive inhibition of some reaction components. Additionally, templates may form secondary structures that interfere with efficient polymerization, and increased production of nonspecific products (particularly primer dimers) may occur.

To overcome these problems, there must be close attention to primer design. Preferential amplification of individual targets may be minimized if each primer set in a multiplexed reaction is designed with a common optimal annealing temperature. Adding dimethyl sulfoxide (DMSO) or other additives (such as glycerol or bovine serum albumin) may help reduce secondary structures in target sequences, thereby improving polymerization efficiency. Salt concentration in the buffer, enzyme concentration, and proper aliquoting and storage of reagents can affect the success of a multiplex reaction. There are references available to aid one in designing and troubleshooting a multiplexed PCR assay (Elnifro et al., 2000; Markoulatos et al., 2002), but in the end the performance characteristics of each assay (including diagnostic and analytical sensitivity and specificity, precision, and accuracy) must be verified by each laboratory.

Real-time PCR (and real-time RT-PCR) assays are becoming a common method for multiplex detection of respiratory viruses, with many recent assays using this technology. Several fluorescent probe chemistries are available for use; two of the most commonly described for detection of respiratory viruses have been TaqMan® and molecular beacon probes. TaqMan probes are labeled with a fluorescent reporter molecule on the 5' end and a quencher molecule at the 3' end. If the target is present, the quenched probe hybridizes with the target, and DNA polymerase (having 5' exonuclease activity) then digests the probe. The reporter molecule is thereby freed from the quencher, and fluorescence is detected (Giulietti et al., 2001). Molecular beacon probes also contain a fluorescent reporter and a quencher molecule, but the probe is constructed so that a secondary hairpin-loop structure is formed. Due to the

secondary structure, the fluorescent reporter and quencher molecules are brought in close proximity, resulting in the quenching of fluorescence. If target is present, the probe's secondary structure is relaxed as the probe hybridizes to the target. This action moves the reporter and quencher molecules away from each other and fluorescence is emitted.

Another type of chemistry, xTAG™, uses fluidic microarrays, which have gained popularity recently for detection of respiratory viruses. In this method, a multiplexed PCR reaction produces amplicons of the targeted respiratory virus(es), followed by removal of excess primers and nucleotides. Target-specific primers (TSP) containing an xTAG universal tag sequence are added and hybridize with complementary target amplicons, if present. Only those TSPs with a perfect complementary match will be extended. Biotin-dCTP is incorporated into the growing strands. Upon completion of this stage, the reaction is introduced to color-coded beads containing molecules that will bind the universal tag on the extended TSPs. A fluorescent reporter molecule is added to the reaction, which binds to biotin. The beads are then analyzed by a flow cytometer. Each color-coded bead is specific for a single virus and is spectrally distinguishable from the other virus-specific beads. Therefore, the instrument can detect the presence of a virus by detecting fluorescence via the reporter molecule and determine which virus(es) are present via the virus-specific bead(s) associated with fluorescence (Luminex Molecular Diagnostics, Inc., Toronto, Canada) (Fig. 24.1).

Another PCR chemistry used in concert with this fluorescent bead technology involves the use of "iso bases," which are synthetically modified cytosine and guanine. Their structure is only slightly changed, but the specificity of their base-pairing is such that they will not pair with the natural bases, only with each other (iC and iG). The iso bases are still recognized by DNA polymerase and are easily incorporated into newly synthesized DNA. In the first PCR reaction, one of the primers of the primer set has a single iC at its 5' terminus. After extension, the resulting iC-product is hybridized with a primer (target-specific extension [TSE]) that contains a virus-specific tag. When the TSE is extended, a biotin-labeled iG is incorporated as the reaction ends at the iC terminus (Fig. 24.2). The products can then be captured and detected as described earlier by the virus-specific beads read by a flow cytometer.

The use of color-coded beads and flow cytometry generates the potential for detecting many more viruses in a single reaction than is currently done with the other methods described here. Similarly, solid-phase microarrays can be used in this manner. These consist of solid supports (glass slides, silicon wafers, or other matrices) spotted with a large number of probes that are spatially arranged and covalently linked to the support. Microarrays may be of low or high density, which refers to the number of sequences (probes)

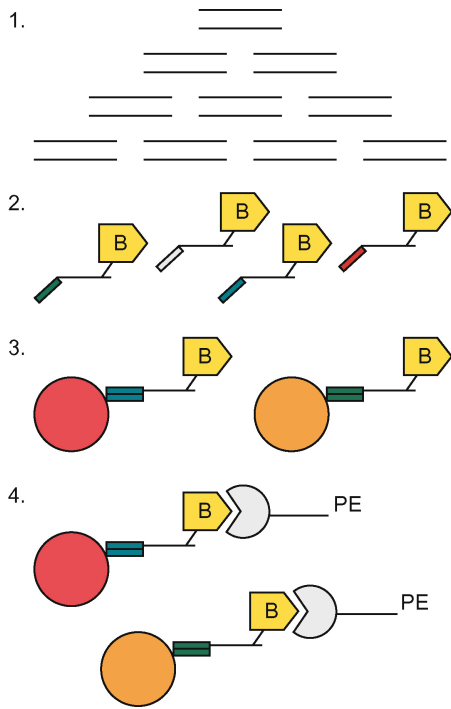

FIGURE 24.1 Universal Tag Sequence (xTAG™) and Fluidic Microarray. (1) Multiplex PCR performed to amplify viral target(s). Excess nucleotides and primers are removed using shrimp alkaline phosphatase and exonuclease I. (2) Viral-specific primers with a universal tag sequence linked to their 5' end are added to the reaction. Hybridization takes place between complementary sequences. Primers are extended by target-specific primer extension (TSPE). The extension product contains biotin-dCTP. (3) Color-coded microspheres are added to the reaction. Each color of bead has an anti-tag sequence on its surface that binds a specific viral target. (4) Streptavidin-phycoerythrin is added. Streptavidin binds biotin; phycoerythrin emits fluorescence. The beads are passed single-file through a flow cytometer detection chamber. The instrument uses two lasers: one spectrally classifies each bead, and the other detects any fluorescence that is associated with each bead. (Luminex Molecular Diagnostics, Inc., Toronto, Ontario, Canada, with permission.)

affixed per area of the chip. Low-density chips may be the most applicable for use in detection of respiratory viruses given their relatively low cost and ease of manufacture.

NASBA

This method primarily targets RNA and thus is especially amenable to detection of viral respiratory pathogens. NASBA employs three enzymes—avian myeloblastosis virus (AMV) reverse transcriptase, T7 RNA polymerase, and RNase H—and two primers. AMV reverse transcriptase also has polymerase activity. Primer 1 contains a T7 RNA polymerase promoter. Because targets and amplicons are single-stranded, no denaturation time is needed when targeting RNA targets only. The isothermal method does not require a thermal cycler and thus is more rapid than methods requiring temperature cycling (Deiman et al., 2002).

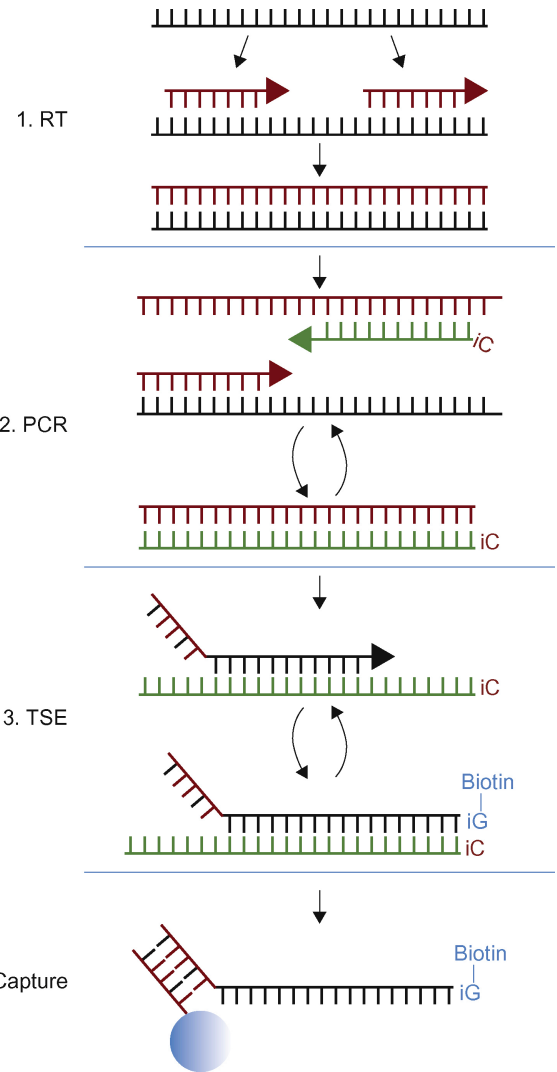

FIGURE 24.2 PCR Using isoC (iC) and iso G (iG) Bases.

(1) RNA targets are reverse transcribed into cDNA. (2) Primers anneal. One primer contains an iC at its 5' terminus. PCR takes place. (3) Target-specific extension primers (TSE) with viral-specific tags hybridize to amplified targets. TSEs are extended by DNA polymerase incorporating a biotin-labeled iG opposite iC on the primer. (4) Color-coded microspheres that have oligo sequences complementary to the viral specific tags on the amplicons capture the proper amplicon. A fluorescent reporter molecule is added to the reaction that binds to biotin. The beads pass through a flow cytometer to analyze which virus-specific bead or beads are associated with fluorescence (positive). (EraGen® Biosciences, Madison, WI, with permission.)

LAMP

LAMP is an isothermal method that uses four target-specific primers and a DNA polymerase with high strand displacement activity (Bst DNA polymerase large fragment) to perform self-cycling strand displacement DNA polymerization. The primers consist of a set of two inner primers (forward and backward) and two outer primers (forward and backward). The inner primers contain sequences of the sense and antisense strands of the target DNA separated by a spacer of

thymidines. Once strand displacement takes place (primed by outer primers), the resultant single-stranded molecules form stem-loops. As cycles proceed, a very large number of amplicons, approximately 10^9 copies, are produced in less than 1 hour. The entire LAMP reaction takes place at 65°C, lending itself to better specificity than what might be seen with other isothermal methods, such as NASBA, which takes place at 41°C (Notomi et al., 2000).

Fluorescent probes are not used in this method. If real-time measurements are desired, a real-time turbidimeter (Eiken Chemical, Tokyo, Japan) may be used to measure turbidity every few seconds. Turbidity results from an increasing production of magnesium pyrophosphate in a positive reaction. However, if a real-time turbidimeter is not available, an end-point measurement may be taken by adding fluorescent dye (e.g., calcein) to the initial reaction that contains manganese. Manganese acts as a fluorescent quencher. As amplification of the target nucleic acid takes place, pyrophosphate ions are produced that bind with manganese, removing its quenching effect and freeing calcein to fluoresce when excited by light from a UV transilluminator. For laboratories without thermal cyclers or real-time detection instrumentations, the LAMP method may provide a viable alternative method for amplification.

Application of Multiplex Methods in Respiratory Virus Detection

LDAs (Including RUOs and ASRs)

Several investigators have used multiplexed assay designs with end-point analysis to detect respiratory viruses. In one example, a set of two multiplexed RT-PCR reactions was used to simultaneously detect both influenza A and B. Gel electrophoresis of the amplification products was used to determine the type of influenza A, if present. The method proved to be a rapid alternative to culture with a lower limit of detection of 10^3 copies/ μ L (Boonsuk et al., 2008). In another study, nested PCR assay was used to detect 18 respiratory viruses and 3 bacteria involved in respiratory tract infections (Lam et al., 2007). A single multiplex reaction of the 21 pathogens would have sacrificed amplification efficiency; therefore, five separate multiplex reactions were used with four to five pathogens being targeted in each reaction. Amplicons were analyzed using 2% gel electrophoresis, which allowed subtyping of some of the pathogens, based on amplicon size. This method proved to be rapid (1 day) with greater sensitivity and specificity than conventional methods. The ability of the molecular method to detect organisms that are difficult or impossible to culture, along with its greater sensitivity, produced an overall positive rate of 48.5% for the nested PCR method compared to 20.1% for culture-based methods. Nested PCR method also detected co-infections in seven (2.3%) of the

samples tested, while conventional methods detected no co-infections (Lam et al., 2007).

Numerous other investigators have used real-time methods and demonstrated variably improved results compared to culture. A two-tube multiplex PCR reaction with molecular beacon probes was designed to detect seven viruses (influenza A, influenza B, RSV, parainfluenza 1, 2, 3, and 4) (Templeton et al., 2004). Respiratory samples ($n = 358$) were tested by conventional culture and this multiplex PCR assay. Nineteen percent of the samples were positive by conventional methods, while 24% were positive by PCR. The additional PCR-positive samples were confirmed by other PCR assays. The mean crossing threshold (Ct) value of the culture-negative/PCR-positive samples was 38, indicating a lower viral load than in concordant samples, which had a mean Ct of 26 ($P < 0.001$). Also, two dual infections were detected by PCR, but not by culture (Templeton et al., 2004). Hymas and Hillyard (2009) used a real-time PCR method to detect multiple respiratory viruses (influenza A, influenza B, and RSV), with commercial RUO reagents and a modified TaqMan method. In this system, the TaqMan probe (still with a 5' reporter molecule and a 3' quencher) also has a minor groove binding (MGB) moiety on the 5' end. Once a DNA-probe hybrid is produced, the MGB moiety tucks into the minor groove. This conformation stabilizes the duplex and protects the probe from the hydrolysis process that normally occurs with TaqMan probes. With these modified TaqMan hybridization probes, the products are not hydrolyzed and are therefore available for melt curve analysis (Hymas and Hillyard, 2009). A melting temperature is the temperature at which half the population of a nucleic acid sequence is single-stranded. In melt curve analysis, the resulting melting temperatures can be specific for individual amplicon sequences. Temperatures in the referenced study were 60.4°C, 66.7°C, and 69.4°C, for influenza A, influenza B, and RSV, respectively. The results of this modified TaqMan probe and melt curve analysis showed 99% concordance with 95 samples positive by culture, FA, or an RT-PCR. The real-time PCR method using modified MGB TaqMan hybridization probes had an improved sensitivity due to its detection of seven positive samples not detected by the other three methods. The presence of the seven additional positive viruses was confirmed by other PCR assays. Lee et al. (2007) selected 101 adult respiratory samples that had been positive for either human rhinovirus (HRV), RSV, parainfluenza (PIV), influenza (InfV), or adenovirus (ADV) by conventional virological methods. The samples were reanalyzed using a commercial RUO system for multiplex PCR and another commercial RUO system for detection. The commercial systems used isoC, isoG, and microsphere flow cytometry to target eight viruses (HRV, RSV, PIV, InfV, ADV, metapneumovirus, coronavirus, and enterovirus). Overall sensitivity and specificity for the method were 94% and 99%, respectively.

Additionally, 103 nasal secretions from symptomatic children were analyzed by the RUO system and compared to culture and FA. Conventional methods detected virus in 23.3% of the samples. Multiplexed PCR detected virus in 71.8% of the samples. Four of the positive samples were found to have two viruses by PCR (Lee et al., 2007). In yet another study, RT-PCR with low-density arrays was used to amplify influenza A RNA, and transcripts were reacted to oligonucleotides fixed to glass slides. The accuracy of the method was 72% (Townsend et al., 2006).

While there are no ASR, RUO, or FDA-cleared reagents or kits for isothermal amplification methods (NASBA and LAMP) in the United States at this time, the methods are presented here due to their past importance (NASBA) and their potential availability in the future (LAMP). Neither of these two isothermal methods requires cycling between different temperatures for primer annealing and template elongation, rendering the use of thermal cyclers unnecessary. These methods are also characteristically more rapid than those requiring thermal cycling. In a study using the NASBA method, over 700 clinical respiratory samples (nasopharyngeal aspirates, swabs, sputa, bronchoalveolar lavages, and endotracheal aspirates) were assayed for RSV A and B using conventional FA, culture, an enzyme-linked immunoassay (ELISA), and NASBA. NASBA outperformed the other methods by detecting RSV in 29.9% of the samples versus culture (8%). FA was performed on approximately 500 samples with a 23.1% positive rate (Deiman et al., 2007). A NASBA assay for SARS-CoV showed equivalent sensitivity when compared to a real-time RT-PCR assay. NASBA had a potential advantage in terms of throughput, taking 1 hour less time to complete than RT-PCR (Keightley et al., 2005).

While commercial methods using LAMP technology are not yet available in the United States, commercial reagents for RNA amplification and SARS-CoV detection by LAMP (Eiken Chemical, Tokyo, Japan) are available overseas. Several investigators have used LAMP for detection of respiratory viral pathogens. Imai et al. (2007) used LAMP technology to detect influenza H5N1 with a reported sensitivity 10-fold higher than that reached with RT-PCR. Sensitivity of LAMP was unchanged whether using end-point fluorescent detection or real-time turbidimetric detection. CoV has been detected using the LAMP method with three sets of primers and real-time turbidimetric detection and has been reported to be 100 times more sensitive than a end-point qualitative RT-PCR followed by gel electrophoresis (Hong et al., 2004). Overall performance was comparable when detection of CoV using LAMP was compared with a quantitative real-time PCR assay (qRT-PCR), with sensitivities of 78% (qRT-PCR) and 71% (LAMP). While sensitivities were similar in samples submitted after 4 days of symptoms onset, for those samples (n = 15) taken early (1–3 days after onset), the detection rate was 95% for qRT-PCR and 60% for LAMP. Although

this study suggested that qRT-PCR was the more sensitive method for early detection of SARS, LAMP may be more practical from a cost and complexity standpoint (no thermal cyclers, no fluorescent probes or real-time instrumentation needs), thereby suggesting its value for laboratories in resource-limited areas (Poon et al., 2005).

FDA-Cleared Kits

Three commercial kits have been cleared by the FDA for in vitro diagnostic use to detect various groups of respiratory viruses in nasopharyngeal swabs from symptomatic individuals. In January 2008, FDA cleared xTAG RVP (Respiratory Viral Panel) (Luminex, Toronto, Canada) and ProFlu+ (Prodesse, Waukesha, WI). In November 2008 Prodesse gained FDA clearance for its ProhMPV+ kit. Both of the Prodesse products employ real-time RT-PCR and TaqMan probes. ProFlu+ detects influenza A, influenza B, and RSV in a single reaction but will not subtype influenza A or RSV. ProhMPV+ will detect the four subtypes of hMPV in a single reaction but will not specify which type is present. The xTAG RVP (Respiratory Viral Panel) uses real-time RT-PCR (and PCR), target-specific primer extension (TSPE), and a fluid-based microsphere array to detect 12 viral targets.

In a study of 353 respiratory samples from symptomatic adult and pediatric patients comparing the detection of influenza A, influenza B, and RSV by viral isolation, antigen immunoassay, and Prodesse's real-time PCR reagents, all methods had comparable specificities ($\geq 99\%$). The sensitivity of real-time PCR was highest (98% for RSV, 94% for influenza) (Liao et al., 2009). A comparison of the Luminex assay (RVP) with an LDA included 1,530 FA-negative respiratory samples. Forty-two percent (42%) of the samples were positive using the LDA versus 45% using RVP. However, of the viruses detected by LDA and undetected by RVP, 51% were adenovirus (n = 26); 27.5% were RSV (n = 14) and, with rare exception, were at low concentration. Additionally, the reduced detection of adenovirus may have been due to the varied serotype distribution seen in this particular geographical location and patient population (Pabbaraju et al., 2008). Other researchers have reported sensitivity of 100% with adenovirus using RVP (Mahoney et al., 2007). Commercial reagents for the detection of respiratory viruses are becoming more numerous. These reagents represent an important move toward identifying a larger number of viruses more quickly than conventional methods.

RECOMMENDATIONS/LIMITATIONS OF AVAILABLE METHODS

Methods currently available to detect respiratory viruses include immunologic techniques, FA, culture, and molecular

methods. Although rapid and potentially useful for cohorting patients, immunologic techniques, specifically EIA, lack sensitivity and specificity to compete with the other methods mentioned. FA is more rapid than culture and can be more rapid than molecular methods. FA results can be subjective, require trained personnel to perform interpretation, and lack the sensitivity of culture and molecular amplification. Culture is the only method that will allow survival of a viable isolate that could be used in further studies, such as susceptibility testing. Molecular methods are typically regarded as the most sensitive and will detect viruses that are difficult or impossible to grow. They are also more likely to detect multiviral infections. Molecular methods can detect nonviable viruses; therefore, a positive result may not predict whether an agent is communicable.

When using commercially prepared multiplexed molecular reagents, close attention must be paid to the limitations noted in each package insert, such as potential cross-reactions. For instance, primers designed to anneal to rhinovirus may also anneal to enterovirus; therefore, a positive rhinovirus reaction may have to be confirmed by another method, if this distinction is considered clinically important. In other multiplexed assays, it may be recommended that negative results are confirmed by other methods (Luminex, 2008). False-negative results may also occur due to the emergence of undiscovered viruses or polymorphisms in target sequences. For instance, some molecular reagents not only detect influenza A, but also type the virus. When using these reagents, if influenza A virus is detected but the type cannot be determined, a novel strain may be the reason. In this case, the sample would need to be secured from further manipulation and the proper governmental public health authorities would need to be contacted for further direction.

The cost of any diagnostic test is an important consideration when determining which assay to use in the laboratory. It is important to include in these costs the expenses related to performance verification studies, prior to test implementation. Performance characteristics of FDA-cleared kits, other commercial reagents, as well as LDAs must be verified by each clinical laboratory before placing an assay into clinical service. LDAs typically require a more extensive, more costly validation process for the clinical laboratory than commercially produced tests. While the cost of a molecular assay can vary widely, ongoing reagent costs per test in a molecular LDA are usually less than with a molecular commercial assay. When calculating the total cost per assay, the labor involved in producing, aliquoting, labeling, and verifying the performance quality of the assay reagents before placing them into service, as well as troubleshooting the large number of variables in a multiplexed assay, can be extensive and should be included in the cost per test calculation. At the same time, packaging of commercial kits/reagents can be misleading. The actual cost per test can be substantially elevated over the vendor's proposed cost once the expense

of performing the quality control required by regulatory agencies is included. Packaging configuration will increase the cost per test if the laboratory's test volume does not allow for optimal use of reagents. Also of note, patents exist for some genetic targets and royalties or licensing fees have to be paid for performing many molecular diagnostic tests. Such fees are often included in the cost of commercial kits, but they must be paid separately when using LDAs. Perhaps the preferred way to use these new multiplexed molecular methods at this time is in algorithms using both conventional and molecular methods. This concept is discussed in a later section of this chapter.

SPECIAL CONSIDERATIONS IN QUALITY MANAGEMENT

Any assay, whether it is FDA cleared for in vitro testing or is a LDA, must be evaluated carefully before being placed into service in a clinical laboratory reporting patient results. Once the performance characteristics have been established and the assay has been approved for clinical use, ongoing quality management practices are required. There should be written standard operating procedures outlining these practices, frequency of performance, acceptable criteria for each, and the action to be taken in case acceptable criteria is not obtained. Documentation of the results and any necessary corrective action should be maintained.

Controls

Certainly, external positive and negative (no template) controls are required on each run. Ideally, a positive control for each target would be tested in each run. In a multiplexed reaction with two or three targets, running a positive control for each target might not add a significant amount to the overall cost of an assay. However, in highly multiplexed reactions with the number of targets in the double digits, the cost can be greatly increased. If controls are not supplied in a kit, laboratories must obtain or produce their own. The availability of commercial controls is limited. Viral particles may be purchased, extracted, and diluted to a concentration that is detectable with the assay. If the laboratory has the capability of manufacturing oligonucleotides or plasmids containing the target sequence, those may also be used as controls. However, in both cases, laboratory personnel would be working with very high levels of targets, and unless a very high level of containment is practiced, the risk of assay contamination is high. To reduce cost, some laboratories test only new lots of reagents with all targets. If the reagents successfully detect all intended targets, then while these reagents are in service, the positive target controls may be rotated as a single positive target control in each assay. If a laboratory desires or is required to run a

positive target control in each run, cocktails of the positive target controls can be made so that multiple targets can be run in a single tube. The number of targets per tube would have to be determined empirically in the laboratory's specific assay. If the laboratory is performing an FDA-cleared assay, the package insert should be read carefully to see if this type of control cocktail is allowed. In addition to positive and negative controls for each run, each new lot number and/or shipment of reagents must be verified for proper performance.

An additional positive control, an internal positive control (IPC), should be added to each sample before extraction and taken through the entire procedure to monitor reaction integrity throughout the assay. An acceptable result for the IPC helps ensure that the sample was extracted properly, the amplification step worked appropriately, there were no inhibitors in the sample, and the detection step was acceptable. Patient samples may have varying levels of inhibitors present. Therefore, during assay validation, laboratories should establish a maximum acceptable IPC Ct that indicates there are no significant inhibitors in the reaction. If, after performing an assay for respiratory viruses, positive and negative controls are acceptable, a sample is negative for the viruses tested, but its IPC failed, the problem could be either that the extraction of that particular sample was inadequate or that sample contains inhibitors. If inhibitors are truly the cause of the IPC failure, this may be remedied by dilution of the sample and re-extraction. If a sample is positive for one of the targeted viruses and its IPC failed, this may be the result of a high viral load that outcompeted the IPC target for dNTPs or other reaction components. Unless contamination is suspected, the positive result may be released.

Quality Monitors

Crossing thresholds of the positive controls should be monitored periodically, usually monthly. Levy-Jennings plots are an effective means to observe for shift or drift in results. The presence of a trend or shift should trigger a comprehensive investigation of assay performance, including reagents, instrumentation, and testing practices. Quantitative measurements, such as optical density (OD) or Ct, used in qualitative assays to define the point at which a result is either positive or negative are initially set by the laboratory or commercial manufacturer during assay development. Cutoff values should be reverified every 6 months or after major changes in reagents or instruments, etc. For laboratories using commercial assays with vendor-established cutoffs, external controls can be used for this purpose.

Due to the mutation potential of viruses, it is important to monitor the strains that currently circulate and whether or not the laboratory's assay remains able to detect these strains (Mahoney, 2008). If the laboratory is using commercial kits, manufacturers should be able to provide that information.

For laboratories using LDAs, one way to accomplish this is to perform a periodic search of online sequence databases for respiratory virus sequences that have been added since the design of the LDA. The primers/probes in the LDA should be evaluated to determine if they are adequate to detect the new sequences. If they are not, they may need to be redesigned and the assay revalidated. Once validated, physicians should be notified of any additional viruses now targeted by the assay. If new strains are reported to be clinically relevant at other times of the year, this information is typically available through Internet listservs of various molecular and virology professional organizations. The CDC website will also have the latest information concerning new strains of respiratory viruses.

Safety

Several extraction methods use guanidine hydrochloride and/or guanidine thiocyanate. Either of these chemicals can form highly reactive compounds when mixed with bleach. An institution's policy of handling and disposing of these chemicals should be closely followed. Notification and training of anyone working with these reagents or any other potentially dangerous chemicals (e.g., ethidium bromide) should be documented. Each new assay or instrument introduced into the laboratory should be evaluated regarding potential safety issues. Personnel should be informed of proper handling, storage, and disposal of reagents. If rooms or equipment are outfitted with items such as ultraviolet light sources, employees should be adequately trained on the safety precautions to be practiced. While fewer clinical laboratories are using radioactivity, those laboratories using it are required to adequately train personnel in the handling, monitoring, and disposal of radioactive materials. Documentation of all training should be maintained.

REPORTING AND INTERPRETATION

Qualitative tests are typically reported as positive, negative, or inhibitory for the viruses targeted by the assay. Interpretation depends on the cutoff values established either by the commercial manufacturer or the laboratory that developed the assay. Those samples with Cts above the cutoff value are reported as negative. Those with Cts below the cutoff value are reported as positive. A laboratory may elect to have a gray zone established around the cutoff value for which it would repeat the assay in duplicate before reporting. Like other laboratory reports, reports for multiplexed molecular assays targeting respiratory viruses should indicate the methodology used and reference range for results. Because available assays vary in the number of viruses each is capable of detecting, it is important to list the viruses being targeted on the report. The proper governmental

public health authorities must be notified if a novel strain is suspected.

CLINICAL INDICATIONS AND RATIONALE

Several methods of detecting the presence of viruses in respiratory samples from symptomatic individuals have been presented in this chapter. Multiplexed molecular methods have been implemented for routine use in many clinical laboratories because of the methods' sensitivity, speed (more rapid than culture), ability to detect viruses that are difficult or impossible to culture, and ability to detect multiple viruses simultaneously. These assays are of high complexity and require a capital expenditure that may not be feasible for all laboratories. A testing algorithm that incorporates several methods may be the best strategy, but it is vital to consult all end-user groups, including medical staff, nursing, and administration, before implementation. The algorithm design would depend on the type of institution, patient demographics, how the information is going to be used for patient care, viral prevalence or seasonality in the area, whether detection of multiple viruses is important, how many viruses should be targeted, assay turn-around time, and if isolates are required for susceptibility testing. One such algorithm might be that more rapid but less sensitive antigen detection tests would be used first. This might be particularly useful in geographical regions with a high prevalence of the viruses detected by these tests. Positive results using these rapid tests would be reported and testing of those samples would stop. Samples with negative results would be tested with more sensitive assays, such as FA. Samples negative by FA would be tested by molecular diagnostics. Another algorithm might have FA as the first line of testing. Some laboratories might opt to run a multiplexed assay for those viruses considered treatable, of high clinical impact, or of high seasonal prevalence (such as influenza and RSV), while other laboratories might use a highly multiplexed assay that targets all available respiratory viral targets.

Molecular methods may play a smaller role in following known-positive patients for infection control purposes. These methods detect viral shedding for days, even weeks after clinical symptoms have subsided and culture results are negative. The clinical predictive value of persistent positive results in such cases is not always well defined, and the interpretation of such results may vary depending on individual institutions and clinical experiences.

FUTURE DIRECTIONS

Molecular techniques will continue to show improvements in speed and accuracy and promise to become part of the routine detection of respiratory viruses. Microarrays

that will test for all types of infectious respiratory agents (viral, bacterial, fungal, parasitic) on a single respiratory sample may emerge and find a place in the clinical laboratory. Customizable formats may allow institutions to design assays incorporating particular targets of interest in a given population. Until the molecular assays are more rapid and less expensive, however, some conventional methods will continue to be used by many laboratories. Immunofluorescent antibody tests may continue to be an important rapid screening test. Cell cultures are being phased out in many clinical laboratories but will remain important in order to cultivate viruses for vaccine development, analyze viruses for antigenic drift, performing susceptibility testing, and discover emerging pathogens.

SUMMARY

Respiratory infections are very common. They are responsible for significant morbidity and mortality and are costly in terms of lost time from work, inappropriate use of antibiotics, and lengthy hospital stays. Laboratory detection of causative agents can influence treatment and allow appropriate infection control measures, potentially saving time and money, promoting quicker recovery for the patient, and lowering the risk of nosocomial transmission of the organism. Molecular testing may be the most sensitive method of detecting respiratory viruses. These methods have been shown to detect multiple viruses in a single sample more often than any of the other methods described and, in addition, can detect viruses that are difficult or impossible to grow. The detection of nonviable organisms may provide additional insight into disease but provides its own challenges in terms of determining clinical significance of positive results. Like many areas of clinical medicine and microbiology, the increasing use of molecular diagnostics for detection of respiratory viruses raises many new questions for the laboratory and the clinical diagnostician, but also promises many benefits as these methods become increasingly available for routine use.

REFERENCES

- Abu-Diab, A., Azzeh, M., Ghneim, R., Ghneim, R., Zoughbi, M., Turkuman, S., et al., 2008. Comparison between pernasal flocked swabs and nasopharyngeal aspirates for detection of common respiratory viruses in samples from children. *J. Clin. Microbiol.* 46 (7), 2414–2417.
- Barger, M., Vestal, D., Engler, H.D., Body, B.A., 2005. Evaluation of Copan Universal Transport Media (UTM-RT) compared to Remel M4 and M4-RT transport media for the recovery of viruses, chlamydia, ureaplasma and mycoplasma. Abstracts. Annual Clinical Virology Symposium, Clearwater Beach, FL.

- Boom, R., Sol, C., Beld, M., Weel, J., Goudsmit, J., Wertheim-van Dillen, P., 1999. Improved silica-guanidinium thiocyanate DNA isolation procedure based on selective binding of bovine alpha-casein to silica particles. *J. Clin. Microbiol.* 37 (3), 615–619.
- Boonsuk, P., Payungporn, S., Chieochansin, T., Samransamruajkit, R., Amonsin, A., Songserm, T., et al., 2008. Detection of influenza virus types A and B and type A subtypes (H1, H3, and H5) by multiplex polymerase chain reaction. *J. Exp. Med.* 215, 247–255.
- Chan, K., Peiris, J., Lim, W., Nicholls, J., Chiu, S., 2008. Comparison of nasopharyngeal flocked swabs and aspirates for rapid diagnosis of respiratory viruses in children. *J. Clin. Virol.* 42, 65–69.
- Deiman, B., Schrover, C., Moore, C., Westmoreland, D., van de Wiel, P., 2007. Rapid and highly sensitive qualitative real-time assay for detection of respiratory syncytial virus A and B using NASBA and molecular beacon technology. *J. Virol. Methods.* 146, 29–35.
- Deiman, B., van Aarle, P., Sillekens, P., 2002. Characteristics and applications of nucleic acid sequence-based amplification (NASBA). *Mol. Biotechnol.* 20, 163–179.
- Encyclopedia of Public Health, 2009. Acute respiratory diseases. Available at: <<http://www.enotes.com/public-health-encyclopedia/acute-respiratory-diseases/print/>>
- Elnifro, E., Ashshi, A., Cooper, R., Klapper, P., 2000. Multiplex PCR: optimization and application in diagnostic virology. *Clin. Microbiol. Rev.* 13 (4), 559–570.
- Fiebelkorn, K., Nolte, F., 2004. RNA virus detection. In: Wilson, L. (Ed.), *Fundamentals of Molecular Diagnostics*. Saunders, St. Louis, pp. 441–445.
- Giulietti, A., Overbergh, L., Valckx, D., Decallonne, B., Bouillon, R., Mathieu, C., 2001. An overview of real-time quantitative PCR: applications to quantify cytokine gene expression. *Methods* 25 (4), 386–401.
- Hong, T.C.T., Le, M.Q., Vuong, C.D., Parida, M., Minekawa, H., Notomi, T., et al., 2004. Development and evaluation of a novel loop-mediated isothermal amplification method for rapid detection of severe acute respiratory syndrome coronavirus. *J. Clin. Microbiol.* 42 (5), 1956–1961.
- Hymas, W., Hillyard, D., 2009. Evaluation of Nanogen MGB Alert® detection reagents in a multiplex real-time PCR for influenza virus types A and B and respiratory syncytial virus. *J. Virol. Methods* 156, 124–128.
- Imai, M., Ninomiya, A., Minekawa, H., Notomi, T., Ishizaki, T., Tu, P., et al., 2007. Rapid diagnosis of H5N1 avian influenza virus infection by newly developed influenza H5 hemagglutinin gene-specific loop-mediated isothermal amplification method. *J. Virol. Methods* 141, 173–180.
- Keightley, M., Sillekens, P., Schippers, W., Rinaldo, C., St. George, K., 2005. Real-time NASBA detection of SARS-associated coronavirus and comparison with real-time reverse transcription – PCR. *J. Med. Virol.* 77 (4), 602–608.
- Kuhn, G., 2008. Viral pneumonia. Available at: <www.Emedicine.medscape.com/eMedicineSpecialties/EmergencyMedicine/Pulmonary/>
- Lam, W., Yeung, A., Tang, J., Ip, M., Chan, E., Hui, M., et al., 2007. Rapid multiplex nested PCR for detection of respiratory viruses. *J. Clin. Microbiol.* 45 (11), 3631–3640.
- Lee, W., Grindle, K., Pappas, T., Marshall, D., Moser, M., Beaty, E., et al., 2007. High throughput, sensitive and accurate multiplex PCR-microsphere flow cytometry system for large-scale comprehensive detection of respiratory viruses. *J. Clin. Microbiol.* 45 (8), 2626–2634.
- Liao, R.S., Tomalty, L.L., Majury, A., Zoutman, D.E., 2009. Comparison of viral isolation and multiplex real-time reverse transcription-PCR for confirmation of respiratory syncytial virus and influenza virus detection by antigen immunoassays. *J. Clin. Microbiol.* 47 (3), 527–532.
- Mahoney, J., Chong, S., Merante, F., Yaghoubian, S., Sinha, T., Lisle, C., et al., 2007. Development of a respiratory virus panel test for detection of twenty human respiratory viruses by use of multiplex PCR and a fluid microbead-based assay. *J. Clin. Microbiol.* 45 (9), 2965–2970.
- Mahoney, J., 2008. Detection of respiratory viruses by molecular methods. *Clin. Microbiol. Rev.* 21 (4), 716–747.
- Mahoney, J., Richardson, S., 2005. Molecular diagnosis of severe acute respiratory syndrome. *J. Mol. Diagn.* 7 (5), 551–559.
- Markoulatos, P., Siafakas, N., Moncany, M., 2002. Multiplex polymerase chain reaction: a practical approach. *J. Clin. Lab. Anal.* 16 (1), 47–51.
- Notomi, T., Okayama, H., Masubuchi, H., Yonekawa, T., Wantanabe, K., Amino, N., et al., 2000. Loop-mediated isothermal amplification of DNA. *Nucleic Acids Res.* 28 (12), e63.
- Pabbaraju, K., Tokaryk, K.L., Wong, S., Fox, J.D., 2008. Comparison of the Luminex xTAG respiratory viral panel with in-house nucleic acid amplification tests for diagnosis of respiratory virus infections. *J. Clin. Microbiol.* 46 (9), 3056–3062.
- Petrich, A., Mahony, J., Chong, S., Broukhanski, G., Gharabaghi, F., Johnson, G., et al., 2006. Multicenter comparison of nucleic acid extraction methods for detection of severe acute respiratory syndrome coronavirus RNA in stool specimens. *J. Clin. Microbiol.* 44 (8), 2681–2688.
- Poon, L., Wong, B., Chan, K., Ng, S., Yuen, K., Guan, Y., et al., 2005. Evaluation of real-time reverse transcriptase PCR and real-time loop-mediated amplification assays for severe acute respiratory syndrome coronavirus detection. *J. Clin. Microbiol.* 43 (7), 3457–3459.
- Qiagen® RNA/DNA Handbook, 1998. Qiagen, Inc., Valencia, CA.
- Sung, R., Chan, P., Choi, K., Yeung, A., Li, A., Tang, J., et al., 2008. Comparative study of nasopharyngeal aspirate and nasal swab specimens for diagnosis of acute viral respiratory infection. *J. Clin. Microbiol.* 46 (9), 3073–3076.
- Templeton, K., Scheltinga, S., Beersma, M., Kroes, A., Claas, E., 2004. Rapid and sensitive method using multiplex real-time PCR for diagnosis of infections by influenza A and influenza B viruses, respiratory syncytial virus and parainfluenza viruses 1, 2, 3, and 4. *J. Clin. Microbiol.* 42 (4), 1564–1569.
- Townsend, M., Dawson, E., Mehlmann, M., Smagala, J., Dankbar, D., Moore, C., et al., 2006. Experimental evaluation of the FluChip diagnostic microarray for influenza virus surveillance. *J. Clin. Microbiol.* 44 (8), 2863–2871.
- Walsh, P., Overmyer, C., Pham, K., Michaelson, S., Gofman, L., DeSalvia, L., et al., 2008. Comparison of respiratory virus detection rates for infants and toddlers by use of flocked swabs, saline aspirates, and saline aspirates mixed in universal transport medium for room temperature storage and shipping. *J. Clin. Microbiol.* 46 (7), 2374–2376.
- Xiang, X., Qiu, D., Hegele, R., Tan, W., 2001. Comparison of different methods of total RNA extraction for viral detection in sputum. *J. Virol. Methods* 94, 129–135.