



Since January 2020 Elsevier has created a COVID-19 resource centre with free information in English and Mandarin on the novel coronavirus COVID-19. The COVID-19 resource centre is hosted on Elsevier Connect, the company's public news and information website.

Elsevier hereby grants permission to make all its COVID-19-related research that is available on the COVID-19 resource centre - including this research content - immediately available in PubMed Central and other publicly funded repositories, such as the WHO COVID database with rights for unrestricted research re-use and analyses in any form or by any means with acknowledgement of the original source. These permissions are granted for free by Elsevier for as long as the COVID-19 resource centre remains active.

RNA pseudoknots

Cornelis WA Pleij

Leiden University, Leiden, The Netherlands

Many new RNA pseudoknot structures have been detected and proposed in the past year. Although we are still waiting for the first detailed structure of a pseudoknot, their role in processes such as translational autoregulation or ribosomal frameshifting has been extensively studied and is now well established. Pseudoknot structures appear to play a pivotal role in small subunit ribosomal RNA and in the noncoding regions of viral RNAs. There are also strong indications that RNA pseudoknots are highly suitable structural motifs for the recognition and binding of proteins.

Current Opinion in Structural Biology 1994, 4:337-344

Introduction

It is common knowledge that Watson-Crick basepairing is the main folding principle in RNA. Although a number of different types of tertiary interactions can shape the final three-dimensional (3D) structure, it was only during the last decade that Watson-Crick basepairing was realized to play a role at the level of tertiary structure formation. This involves base-pairing between a loop region in an orthodox secondary structure and a complementary sequence outside that loop. This type of basepairing leads to what is called a pseudoknot structure. It is now clear that in many cases the function of an RNA molecule can only be understood in terms of such pseudoknot formation.

The simplest form of pseudoknot arises when a stretch of nucleotides from a hairpin loop basepairs with a complementary single-stranded non-loop sequence close to the hairpin. Fig. 1 illustrates the four basic elements of a pseudoknot of this type, showing the relative orientation of stems 1 and 2 (S1, S2) and the connecting loops 1 and 2 (L1, L2). In the case where both stem regions are contiguous, a stacking of the two helices becomes possible (as shown in Fig. 1). In principle, each of the two loops may consist of hundreds of nucleotides, possessing their own secondary structure. There is some debate, however, as to whether pseudoknots formed by long-range basepairing interactions, including stems formed by loop-loop interactions, should be called tertiary interactions, and whether the term pseudoknot should be restricted to the simpler case illustrated in Fig. 1. For a discussion of these aspects of definition and classification see [1-4].

This review evaluates the current status of our understanding of RNA pseudoknot of structure and function, based on the advances made during the past year. It should be stressed that the number of pseudoknot

structures proposed in the literature is rapidly growing, but that often these proposals are not supported by experimental results and/or covariation search, and it is for that reason that these are given less attention here. (For recent reviews on RNA pseudoknots, covering the period before 1993, see [1,2,4].)

Structure

NMR and X-ray diffraction

The progress made in the past year in elucidating the 3D structure of an RNA pseudoknot was only modest. The near future looks more promising, however, as a number of groups are intensively studying pseudoknot-containing RNA fragments with high resolution NMR spectroscopy techniques (LX Shen, J Santa Lucia Jr, I Tinoco Jr, abstract 2, Alternate Readings of the Genetic Code, Parknasilla, Ireland, May 1993; M van der Graaf, BALM Deiman, MP Veldhoven, CWA Pleij, H van den Elst *et al.*, VIIIth Conversation in the Discipline of Biomolecular Stereodynamics, Albany, June 1993). Biophysical studies on RNA pseudoknots suffer from many problems, in that apart from dealing with RNA, which has its own drawbacks for biophysical studies, RNA fragments that can potentially form pseudoknots appear to be apt to give aggregates, alternative conformations, or duplexes, because of their intrinsically high basepairing capabilities and their relatively low stability. The most important structural contribution so far has come from the group of Tinoco and coworkers [5], who obtained evidence for the coaxial stacking of stems S1 and S2 when studying a synthetic RNA oligonucleotide with NMR. The helical segments S1 and S2 were found to be of the A-type, but less information was obtained about the conformation of the loop regions L1 and L2. This means that the occurrence

Abbreviations

3D—three-dimensional; BMV—brome mosaic virus; L—loop; NGF—nerve growth factor; S—stem; TYMV—turnip yellow mosaic virus; UTR—untranslated region.

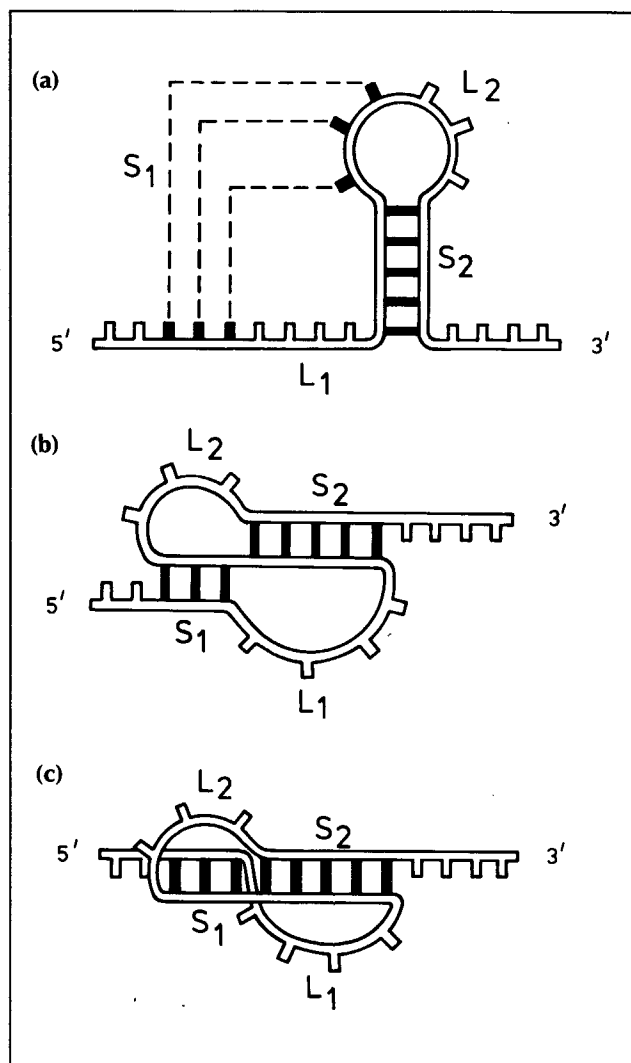

Fig. 1. The formation of a simple RNA pseudoknot involving a hairpin loop. (a) Conventional representation, showing the nucleotides from the loop (L2) basepairing with a complementary sequence outside the loop (L1). (b) Schematic folding resulting in the formation of the two stem regions (S1 and S2). (c) Formation of the quasi-continuous helix upon stacking of the two stems. S1 and S2 represent the two stem regions, L1 and L2 the two connecting loops. Watson-Crick basepairs are indicated by the black bars.

of triple interactions between L1 or L2 with the stems S2 and S1, respectively, remains an open question. The possibility of such interactions must certainly be envisaged since 'nucleoside triples' have been observed in a structural element of the Group I intron that has certain features in common with pseudoknots [6].

The successful crystallization of a pseudoknot-harboring RNA fragment further fosters our expectation that the elucidation of the detailed structure of an RNA pseudoknot will only be a matter of time [7*].

Topology

A recurrent question related to pseudoknot structure is that of the possible existence of real knots in natural RNA (see [1]). A few papers last year reported topo-

logically real knot formation in single-stranded nucleic acids. Interlocking RNA circles were described by Winter *et al.* [8] as a product of aberrant splicing in a yeast mitochondrial precursor for the large ribosomal subunit RNA, as a result of an activation of cryptic opening sites in the 5' exon of mutant precursors. The first, small circle is derived from part of the 5' exon and the second, large one comprises the intron. The results could be explained by the formation of a pseudoknot structure involving the internal guide sequence (IGS).

Knotting has also been described for chemically synthesized, single-stranded DNA molecules ([9], and references therein). The basepairing schemes in these circular molecules of 70, or more, nucleotides are reminiscent of RNA pseudoknots. The ligation of the 3' to the 5' end gives rise to trefoil and figure-eight knots depending on the presence or absence of Z-DNA structure in one of the two helices. It would be very interesting to see whether similar structures can be fashioned with single-stranded RNAs. A study of such RNA real knots may likewise reveal flexibility constraints that could be useful for understanding pseudoknot structures.

Function

5' and 3' untranslated regions in viral RNAs

Plant viruses

The RNA pseudoknots, as we know them today, were first discovered in the tRNA-like structure of some plant viral RNAs. Although aminoacylation at the 3' end of turnip yellow mosaic virus (TYMV) RNA takes place *in vivo*, probably as a necessary step in the multiplication of the virus [10], it is still not known why a pseudoknot is specifically used for the proper folding of the tRNA-like structure. This problem received a new twist with the observation by Haenni and coworkers [11] that a 3' terminal fragment of TYMV RNA of as few as 38 nucleotides, harbouring just one pseudoknot, is sufficient for specific initiation of minus-strand synthesis. If this is indeed the case, it would be interesting to know which part of this pseudoknot is responsible for the recognition of the viral replicase.

It has been difficult to understand the resemblance of the tRNA-like structure of brome mosaic virus (BMV), encompassing some 170 nucleotides, to the canonical elongator tRNA^{Tyr}. A recent, careful and extensive study by Felden *et al.* [12*], using chemical modification, enzymatic digestion and computer modeling has led to an improved and more detailed structure. Moreover, this Strasbourg group obtained experimental evidence for a pseudoknot just upstream of the tRNA-like structure, as predicted earlier in my laboratory.

These conserved pseudoknots just downstream of the stop codon in the 3' untranslated region (UTR) are a recurrent motif in many non-polyadenylated plant viral RNAs. In some cases only one pseudoknot is present, as reported recently for TYMV RNA [13]. Other viral

RNAs usually harbour more pseudoknots, even up to eleven in a row like in some tobamoviruses (A Gulyaev, C Pleij, unpublished data).

Two papers that appeared in 1993 dealt with the function of these 3' UTR-pseudoknots [14•,15]. A few years ago Gallie and coworkers [14•] found that the three consecutive pseudoknots PK₁-PK₃ in tobacco mosaic virus RNA (Fig. 2) promote efficient translation of the viral RNA in conjunction with the 5' leader. As such, they mimic the function of the polyA tail in cellular mRNAs. In a very extensive mutagenesis analysis, Gallie and coworkers [14•] have pinpointed which part of the 72 base stalk, or upstream pseudoknot domain (UPD), mediates this regulation; it turned out that both the higher order structure of PK₂ and PK₃ and their conserved sequences, especially in the 3' proximal PK₃, are essential for translation. Using band shift analysis they also demonstrated that this upstream pseudoknot domain is specifically recognised by proteins from wheat germ or carrot extracts. These proteins also recognise the 5' leader, thereby paralleling the properties of polyA-binding proteins.

Interestingly, Hall and coworkers [15] present a somewhat different conclusion regarding the function of the pseudoknots in the 3' UTR of Brome mosaic virus (BMV) RNA. The results of deletion studies on BMV RNA 3, cotransfected with RNA 1 and RNA 2, point to a minor role in translational control. Rather, these pseudoknots seem to contribute to the overall replica-

tion of the BMV RNAs. Further studies on other plant viral RNAs are needed to clarify this point.

Picornaviruses

It has been proposed that pseudoknots are present in the 5' UTR of picornaviral RNAs, such as foot and mouth disease virus (FMDV), encephalomyocarditis virus (EMCV) or hepatitis A virus (HAV). These pseudoknots of the simple type (as shown in Fig. 1) are located upstream of the 'ribosomal landing pad' and border long single-stranded regions [16,17]. No functional role for these pseudoknots has been reported as yet.

The 'ribosome landing pad' (RLP) itself has also been described as containing a few pseudoknots, both in the human enterovirus and rhinovirus RNAs [18], and in the cardiovirus, hepatitis A and aphtovirus RNAs [17]. However, some of these pseudoknots, proposed on the basis of sequence comparisons and computer prediction, clearly need experimental verification because the predictions are either not supported by covariations, or actually show contra-indicators in related sequences. If present, the role of these pseudoknots in the cap-independent initiation of protein synthesis remains to be established.

Two different models for 3' UTR folding of the poliovirus genome were recently proposed. Both models contain a pseudoknot structure, possibly implicated in viral replication [19•,20]. The first, presented by Jacob-

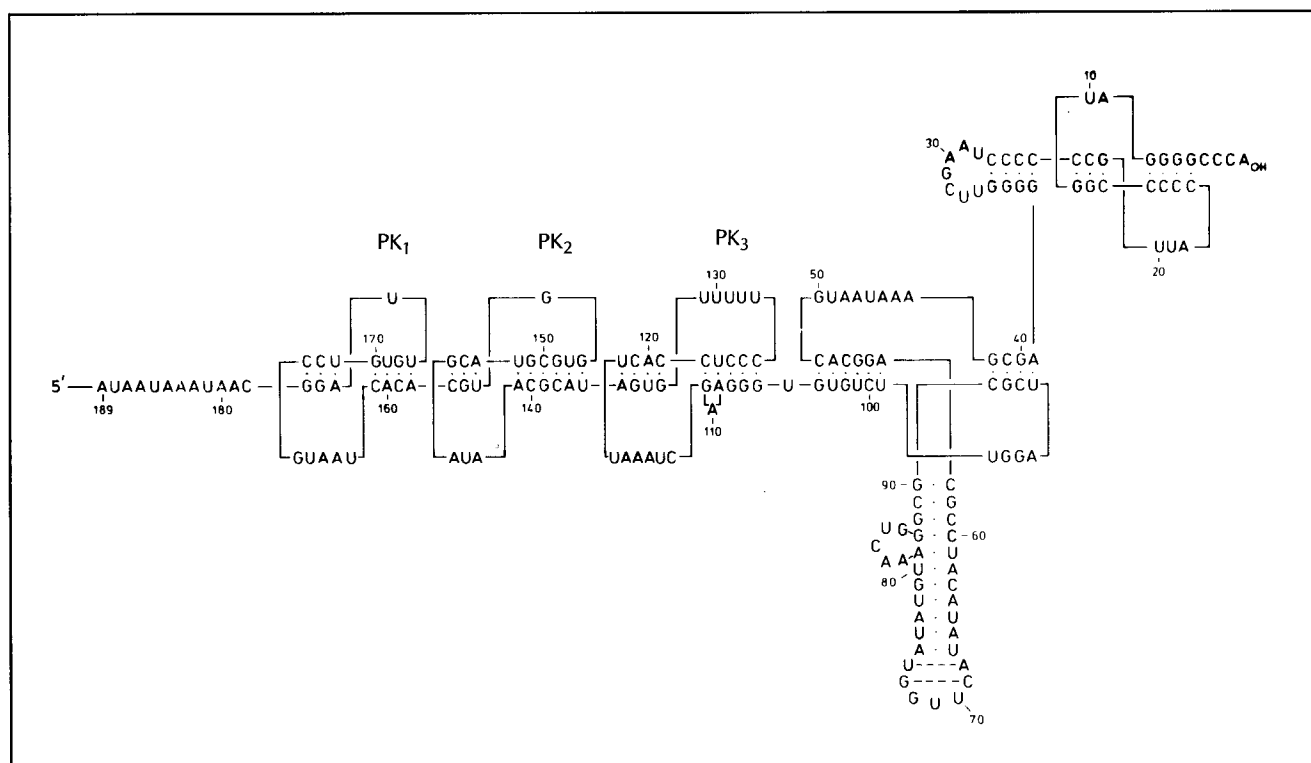

Fig. 2. The folding of the 3' UTR of tobacco mosaic virus (TMV) RNA. The tRNA-like structure comprises nucleotides 1-105. The upstream pseudoknot domain (UPD), or stalk, consists of three consecutive pseudoknots (PK₁-PK₃) and is formed by nucleotides 106-179.

son *et al.* ([19^{*}], see Fig. 3a) was supported both by mutational studies and by structure probing, although the phylogenetic evidence is rather weak. The proposal has, to my knowledge, the unique feature that a stretch from the coding sequence is needed for pseudoknot formation. In the second model, proposed by Pilipenko *et al.* [20], the pseudoknot-forming basepairing takes place with the loop of the downstream-located hairpin (Fig. 3b). An attempt was made to fold the 3' UTR in a tRNA-like structure, including an equivalent of the T- and D-loop interaction of tRNA. In my view this resemblance is hardly visible, however, and the three-dimensional model could be called, at best, tRNA-like-like.

These two studies at least show that the spatial folding of the 3' terminus of the enteroviral RNAs may be rather complicated, or may harbour alternative conformations.

Translation

Ribosomal RNA

On the basis of phylogenetic comparisons three different pseudoknot structures have been proposed in the small subunit rRNA (see also [4,21]). The nature of two of them (pseudoknots I and III in Fig. 4) have now been confirmed by mutagenesis, and a beginning has been made towards understanding their functional role in ribosome activity. Powers and Noller [22] obtained evidence for a possible essential function of the pseudoknot involving the 530-loop (pseudoknot III). A similar *in vivo* study was performed by Brink *et al.* [23^{*}] on pseudoknot I, using their so-called specialized ribosome system. From an elegant set of experiments, these authors concluded that mutations disrupting or weakening this tertiary interaction affected the formation of the 70S ribosomal complex. Similar results were obtained by Dammel and Noller [24] who studied a C to U substitution at position 23 in the 5' terminal pseudoknot helix. This mutant, which is cold-sensitive and

impaired in assembly, also leads to accumulation of free 30S subunits in the cell. The hypothesis that these strongly conserved pseudoknots play a role as crucial conformational switches still holds.

Many potential tertiary interactions have been proposed in the large ribosomal subunit RNA (see [25]). Kooi *et al.* [26] obtained evidence that one such interaction in domain III in the 26S rRNA of yeast is essential. The loop-loop interaction of two base pairs is necessary for binding of ribosomal L25 as deduced from an *in vitro* binding assay.

Translational regulation

The presence and functional significance of pseudoknots in the 5' leader of prokaryotic mRNAs is now a well-documented story. In 1993 a few papers appeared that contributed a great deal to our insight into this type of translational regulation. New data have been presented about the pseudoknot-dependent repression mechanisms of ribosomal protein operons in *Escherichia coli* [27^{*},28,29^{*}]. In the case of the complex pseudoknot regulating the alpha-operon, Draper and coworkers [27^{*},28] concluded from S4 binding studies and 'toeprint' assays that the repressor protein S4 does not simply 'displace' the ribosome from the mRNA, but rather exerts its activity by an allosteric effect. The so-called inactive conformation containing the intact pseudoknot structure binds S4 rapidly and tightly. This complex is still able to bind 30S subunits, but lacks the possibility of forming a proper initiation (or preternary) complex with tRNA_{fMet}.

Following a similar experimental approach for ribosomal protein S15, Philippe *et al.* [29^{*}] reached the same conclusion in that the protein, by stabilizing the pseudoknot-containing conformation of the mRNA coding for S15, also blocks the ribosome in a preinitiation complex. The unexpected outcome of these studies is that the pseudoknot structure displays the

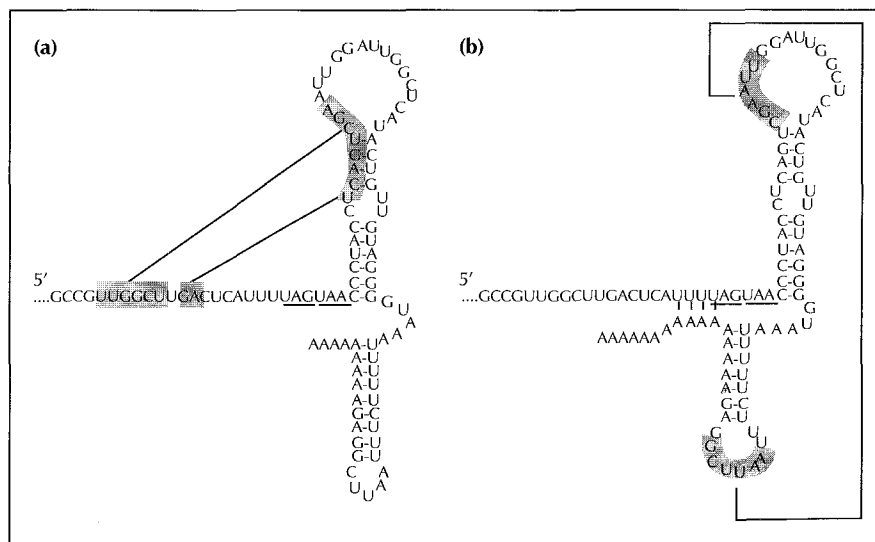

Fig. 3. Two different pseudoknot structures predicted at the 3' terminus of poliovirus RNA. The translational stop codons are underlined. Lines connecting boxed regions indicate potential base-pairing interactions. (a) Adapted from [19^{*}]. (b) Adapted from [20].

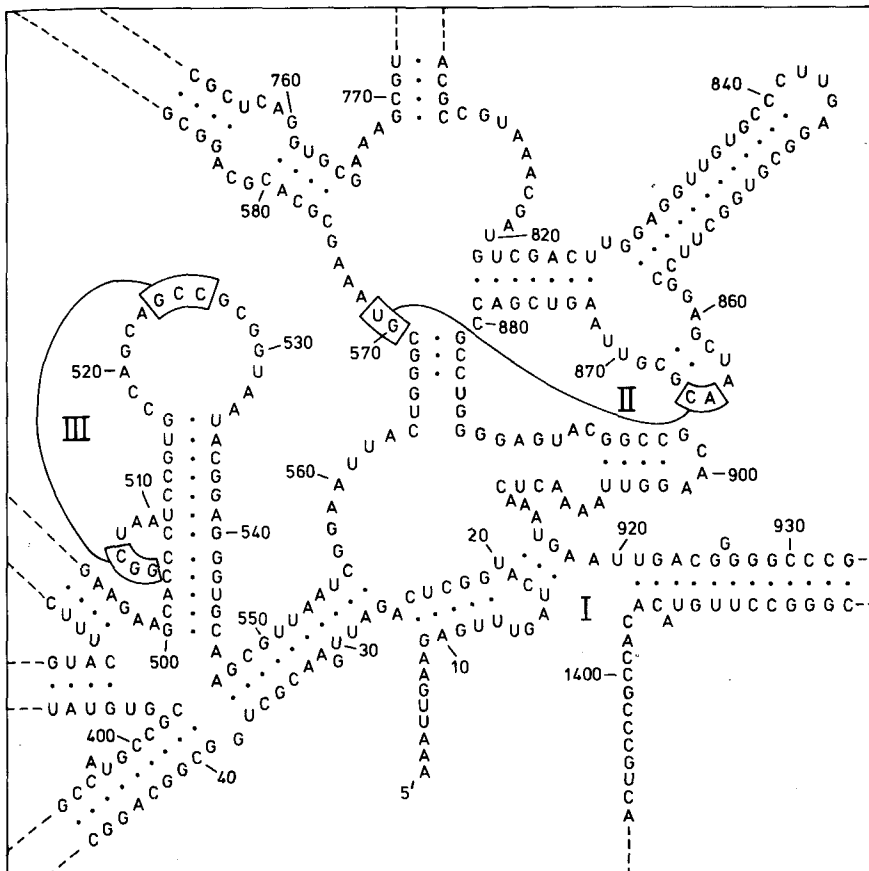

Fig. 4. The secondary structural core of the *E. coli* 16S ribosomal RNA. Pseudoknots are numbered by Roman numerals (I–III). Basepairing interactions giving rise to pseudoknots II and III are indicated by solid lines. The numbering of the nucleotides is as for the entire 16S rRNA.

property of providing determinants for both repressor and ribosome recognition.

The translational repression by the bacteriophage T4 gene 32 protein also requires a pseudoknot structure in the 5' leader, as first shown by Gold and coworkers [30]. The pseudoknot structure is of the classical type (as shown in Fig. 1), and located at the very 5' end in this case, functions as a nucleation point for cooperative binding of gene 32 protein, which then proceeds in the 3' direction covering the initiation codon. This model was confirmed recently and the important pseudoknot structural determinants for binding the protein were determined [31]. How this single strand specific protein binds so tightly to the compact pseudoknot structure remains an intriguing question.

Ribosomal frameshifting

One of the clearest examples of the functional role of pseudoknot structures is found in the case of programmed translational errors like ribosomal frameshifting and translational readthrough. Brierley *et al.* [32] were the first to convincingly show that the efficiency of -1 frameshifting in a coronaviral RNA was strongly dependent on a pseudoknot structure downstream of a slippery heptanucleotide sequence. Since then a large number of other viral RNAs were shown to use the

same mechanism for expression of overlapping genes in the -1 phase.

I will not review here all the new viruses, or virus groups, for which pseudoknots were predicted to play a role in the translation of their overlapping genes, but rather I shall focus on some new aspects and new types of pseudoknots. For a more detailed discussion of pseudoknot-dependent frameshifting and readthrough and other related 'alternative readings of the genetic code', the reader is referred to an excellent review of a recent meeting on this subject [33**].

Most of the pseudoknots involved in ribosomal frameshifting are of the classical type, as illustrated in Fig. 1, though the stems and loops can be relatively large. Sometimes the structures involved in this process can be quite complex, as was recently shown by Herold and Siddell [34*]. They obtained evidence that a third stem structure, S3, is a necessary component of the hepatitis C virus (HCV) 229E pseudoknot in the overlap of open reading frames 1a and 1b. Stem S3 results from basepairing of loop L2 with a region downstream of the classical pseudoknot. This gives rise to a complex or 'elaborated' pseudoknot which is reminiscent of the structure present in the alpha-operon of *E. coli* (see above). Apart from the two possible stacking modes of the three stems, this extra stem may contribute to the stability of the entire pseudoknot structure and thereby increase the pausing time of the ribosome.

It is generally thought that ribosomal pausing caused by the (stable) pseudoknot is a prerequisite for efficient frameshifting. Heel-printing experiments on the L1 double-stranded RNA virus of *Saccharomyces cerevisiae* have provided evidence that ribosomes have a decreased rate of movement through a pseudoknot [35]. This ribosomal arrest at the pseudoknot was further substantiated by Somogyi *et al.* [36•] who observed a new translational intermediate when a pseudoknot was inserted at a specific location in an influenza messenger RNA. A simple stem-loop structure with the same basepairs as the pseudoknot was less effective in stalling the ribosome, though still more than expected on the basis of its frameshifting efficiency.

Although -1 frameshifting does occur in prokaryotes, no evidence has so far been reported for the requirement of a pseudoknot structure. In this respect, it is interesting to know whether eukaryotic frameshifting signals, including the pseudoknot, are active in *E. coli*. Garcia *et al.* [37] examined the eukaryotic frameshift signal of beet western yellows virus (BWYV) RNA in *E. coli* [37]. They showed that the frameshifting observed, which is relatively low in both the prokaryotic and the eukaryotic system, is only slightly sensitive to a disruption of the pseudoknot. However, it cannot be excluded that a pseudoknot-including frameshift signal is dependent on other requirements in the prokaryote, e.g. a different spacer length between pseudoknot and shifty heptanucleotide or a more stable pseudoknot.

A pseudoknot-dependent frameshift in beet western yellow virus in RNA was also reported by Kujawa *et al.* [38], in contrast to an earlier paper which reported the involvement of a hairpin structure only [39].

Exactly how pseudoknots stimulate frameshifting (or readthrough) still remains unclear, although it could well be that the ribosome cannot easily handle this structure during the necessary unwinding. This may be due to the presence of structurally unusual connecting loops, especially L2 which is closest to the shifty heptanucleotide may be responsible for the stalling of the ribosome (see [33••]).

Hepatitis delta virus ribozyme

The genomic and antigenomic RNAs of hepatitis delta virus contain a self-cleavage site formed from 85 nucleotides. Three different secondary structure models have been proposed for the region around this cleavage site, and none of them resemble the canonical hammerhead or hairpin/paperclip motif. One of the three models involves a pseudoknot-containing structure with four basepaired regions (see [40] and references therein). The pseudoknot can be represented by the basepairing of a big hairpin-containing bulge loop with a sequence near the 5' end of the 85 nucleotides [4]. The proposed pairings have now been tested and confirmed by structure mapping and mutational analysis by various groups [40–43]. Two of the

stems that are essential for pseudoknot formation were found to be indispensable for the catalytic activity.

Conclusions

It has become clear that pseudoknots are an important structural motif in RNA folding, and that they are essential for the biological activity of many RNA molecules. These pseudoknot interactions are usually detected in a way that is basically no different from establishing any other double-stranded region in RNA — that is, by means of techniques such as sequence comparisons, chemical modification and enzymatic digestion, computer prediction and site-directed mutagenesis. In fact, one needs a minimum of two basepaired regions in order to describe a pseudoknot structure. Many new pseudoknots have been proposed on the basis of these techniques and it is safe to predict that the list of proposed and proven pseudoknot structures will keep growing in the near future. On the other hand, with RNA pseudoknots being both popular and fashionable at the current time [21], some authors sometimes seem to forget that pseudoknot structures also need some experimental verification or support from sequence comparisons, especially when potential interactions of three basepairs or less are involved. Generally speaking, pseudoknots may serve to bring together RNA regions that are far apart in the sequence, so that a compact and biologically active RNA molecule is formed. In this way, RNA pseudoknots may be compared somewhat with S–S bridges in proteins (see [4] for a more elaborate discussion).

There are, however, a few fundamental aspects of pseudoknot structures that deserve special attention. First of all, it is essential that the structure of one or more pseudoknots of the simple type (Fig. 1) is determined at atomic level, because certain mechanisms and processes seem to be directly related to, or dependent on, the proper folding of this motif. Good examples are the pseudoknot-dependent frameshifting in many viral RNAs, the binding of gene 32 protein to the pseudoknot in its own messenger RNA, or the regulation of translation by the three consecutive pseudoknots in the 3' UTR of tobacco mosaic virus RNA.

It is also intriguing that a pseudoknot structure is sometimes specifically recognized by proteins. Therefore, it is of utmost importance to determine which structural features are responsible for this specific recognition. The observations of Gold and coworkers [30] are highly relevant in this respect. Using their SELEX method for selecting RNAs that bind with a high affinity to a certain protein, they often find that the 'winning' ligands are pseudoknots. This was first discovered for the HIV reverse transcriptase [44••], while a second example was provided when the nerve growth factor (NGF) was tested [45]. Both pseudoknot structures were of the type illustrated in Fig. 1, except that an extra hairpin is present in the L2 loop in the case of NGF. These findings suggest that pseudoknot struc-

tures are very well equipped for binding to proteins. It is obvious that elucidation of the detailed structure of a pseudoknot-protein complex is highly desirable.

References and recommended reading

Papers of particular interest, published within the annual period of review, have been highlighted as:

- of special interest
- of outstanding interest

1. Mans RMW, Pleij CWA: RNA Pseudoknots. In *Nucleic Acids and Molecular Biology*, vol 7. Edited by Eckstein F, Lilley DMJ. Berlin, Heidelberg: Springer-Verlag; 1993:250-270.
 2. Westhof E, Jaeger I: RNA Pseudoknots. *Curr Opin Struct Biol* 1992, 2:327-333.
 3. Wyatt JR, Tinoco I Jr: RNA Structural Elements and RNA Function. In *RNA World*. Edited by Gesteland RF, Atkins JF. Cold Spring Harbor Laboratory Press; 1993:465-496.
 4. Tendam E, Pleij K, Draper D: Structural and Functional Aspects of RNA Pseudoknots. *Biochemistry* 1992, 31:11665-11676.
 5. Puglisi JD, Wyatt JR, Tinoco I Jr: Conformation of an RNA Pseudoknot. *J Mol Biol* 1990, 214:437-453.
 6. Chastain M, Tinoco I Jr: Nucleoside Triples from the Group I Intron. *Biochemistry* 1993, 32:14220-14228.
 7. Doudna JA, Grosshans C, Gooding A, Kundrot CE: Crystallisation of Ribozymes and Small RNA Motifs by a Sparse Matrix Approach. *Proc Natl Acad Sci USA* 1993, 90:7829-7833.
- The value of this paper is mainly its methodological achievements and on the good prospects it offers for all of us working in the 'RNA world' because of its prescriptions for the successful crystallization of a number of RNA fragments and molecules.
8. Winter AJ, Alkema MJ, Groot-Koerkamp MJ, van der Horst G, Mul Y, Tabak HF: Interlocked Circle Formation by Group I Introns: Structural Requirements and Mechanism. *Nucleic Acids Res* 1993, 21:3217-3226.
 9. Wang H, Shou MD, Seeman NC: Tight Single-Stranded DNA Knots. *J Biomol Struct Dyn* 1993, 10:853-863.
 10. Tsai C-H, Dreher TW: Turnip Yellow Mosaic Virus RNAs with Anticodon Loop Substitutions that Result in Decreased Valylation Fail to Replicate Efficiently. *J Virol* 1991, 65:3060-3067.
 11. Gargouri-Bouazid R, David C, Haenni A-L: The 3' Promoter Region Involved in RNA Synthesis Directed by the Turnip Yellow Mosaic Virus Genome in vitro. *FEBS Lett* 1991, 294:56-58.
 12. Felden B, Florentz C, Giegé R, Westhof E: Solution Structure of the 3' End of Brome Mosaic Virus Genomic RNAs. Conformational Mimicry with Canonical tRNAs. *J Mol Biol* 1994, 235:508-531.
- A valuable report illustrating (again) the power of combining extensive analysis with chemical modification, and enzymatic digestion with computer modeling. At the same time it tells the story of a tRNA-like structure whose structural features were not easily to reconcile with those of canonical tRNA.
13. Tsai C-H, Dreher TW: Second-site Suppressor Mutations Assist in Studying the Function of the 3' Noncoding Region of Turnip Yellow Mosaic Virus RNA. *J Virol* 1992, 66:5190-5199.
 14. Leathers V, Tanguay R, Kobayashi M, Gallie DR: A Phylogenetically Conserved Sequence within Viral 3' Untranslated RNA Pseudoknots Regulates Translation. *Mol Cell Biol* 1993, 13: 5331-5347.

A very extensive mutational analysis of the pseudoknot stalk in the 3' UTR of TMV RNA. We will certainly hear more about this system in the future and it will be most interesting to know how these pseudoknots mimic the polyA tail of cellular messenger RNA. The pseudoknot is compared with the 'neighbouring' tRNA-like structure, and possibly represents another example of conformational mimicry.

15. Lahser FC, Marsh LE, Hall TC: Contributions of the Brome Mosaic Virus RNA-3' Nontranslated Region to Replication and Translation. *J Virol* 1993, 67:3295-3303.
 16. Duke GM, Hoffman M, Palmenberg AC: Sequence and Structural Elements that Contribute to Efficient Encephalomyocarditis Viral RNA Translation. *J Virol* 1992, 66:1602-1609.
 17. Le S-Y, Chen J-H, Sonenberg N, Maizel JV: Conserved Tertiary Structural Elements in the 5' Non-Translated Region of Cardiovirus, Aphtovirus and Hepatitis A Virus. *Nucleic Acids Res* 1993, 21:2445-2451.
 18. Le S-Y, Chen J-H, Sonenberg N, Maizel JV: Conserved Tertiary Structure Elements in the 5' Untranslated Region of Human Enteroviruses and Rhinoviruses. *Virology* 1992, 191:858-866.
 19. Jacobson SJ, Konings DAM, Sarnow P: Biochemical and Genetic Evidence for a Pseudoknot Structure at the 3' Terminus of the Poliovirus Genome and its Role in Viral RNA Amplification. *J Virol* 1993, 67:2961-2971.
- This paper shows us that polyadenylated viral RNAs can also harbour pseudoknotted structures in their 3' untranslated region. A direct role in the process of viral replication seems to be likely, but the story of plant viral RNAs tells us to be cautious before hypothesizing about a possible function for this pseudoknot.
20. Pilipenko EV, Maslova SV, Sinyakov AN, Agol VI: Towards Identification of *Cis*-Acting Elements Involved in the Replication of Enterovirus and Rhinovirus RNAs: a Proposal for the Existence of tRNA-Like Terminal Structures. *Nucleic Acids Res* 1992, 20:1739-1745.
 21. Gutell RR: Comparative Studies of RNA: Inferring Higher-Order Structure from Patterns of Sequence Variation. *Curr Opin Struct Biol* 1993, 3:313-322.
 22. Powers T, Noller HF: A Functional Pseudoknot in 16S Ribosomal RNA. *EMBO J* 1991, 10:2203-2214.
 23. Brink MF, Verbeet MP, de Boer HA: Formation of the central pseudoknot in 16S rRNA is essential for initiation of translation. *EMBO J* 1993, 12:3987-3996.
- Like the previous paper [22], this study strongly fosters the idea that pseudoknotted structures are a fundamental structural motif in this ancient molecule. These pseudoknots in the core of the 16S ribosomal RNA are built from heavily conserved regions suggesting that they have played a fundamental role in protein biosynthesis from the very beginning. It will be interesting to see whether further experimentation will confirm the idea of pseudoknots as conformational switches. This paper is also valuable for those who want to know more about the merits of the 'specialized ribosome' system.
24. Dammel CS, Noller HF: A Cold-Sensitive Mutation in 16S rRNA Provides Evidence for Helical Switching in Ribosome Assembly. *Genes Dev* 1993, 7:660-670.
 25. Gluick TC, Draper DE: Tertiary Structure of Ribosomal RNA. *Curr Opin Struct Biol* 1992, 2:338-344.
 26. Kooi EA, Rutgers CA, Mulder A, van't Riet J, Venema J, Raué HA: The Phylogenetically Conserved Doublet Tertiary Interaction in Domain III of the Large Subunit rRNA is Crucial for Ribosomal Protein Binding. *Proc Natl Acad Sci USA* 1993, 90:213-216.
 27. Spedding G, Draper DE: Allosteric Mechanism for Translational Repression in the *Escherichia coli* α Operon. *Proc Natl Acad Sci USA* 1993, 90:4399-4403.
- Apart from dealing with the most complex pseudoknot structure described so far, this paper is also one of the better examples of a detailed study of the structure-function relationship of an RNA pseudoknot.

28. Spedding G, Gluick TC, Draper DE: Ribosome Initiation Complex Formation with the Pseudoknotted α Operon Messenger RNA. *J Mol Biol* 1993, 229:609–622.
29. Philippe C, Eyermann F, Bénard L, Portier C, Ehresmann B, Ehresmann C: Ribosomal Protein S15 from *Escherichia coli* Modulates its Own Translation by Trapping the Ribosome on the mRNA Initiation Site. *Proc Natl Acad Sci USA* 1993, 90:4394–4398.

It is not surprising that this paper was published in tandem with that of Spedding and Draper [27^{*}]. Apart from the same type of techniques used, like toeprinting, the outcome of this study is similar. Together, both studies have increased our understanding of this type of translational feedback regulation.

30. McPheeters DS, Stormo GD, Gold L: Autogenous Regulatory Site on the Bacteriophage T4 Gene 32 Messenger RNA. *J Mol Biol* 1988, 201:517–535.
31. Shamoo Y, Tam A, Königsberg WH, Williams KR: Translational Repression by the Bacteriophage T4 Gene 32 Protein Involves Specific Recognition of an RNA Pseudoknot Structure. *J Mol Biol* 1993, 232:89–104.
32. Brierley I, Digard P, Inglis SC: Characterization of an Efficient Coronavirus Ribosomal Frameshifting Signal: Requirement for an RNA Pseudoknot. *Cell* 1989, 57:537–547.
33. Farabaugh PJ: Alternative Readings of the Genetic Code. *Cell* 1993, 74:591–596.

This excellent review is obligatory for everyone who still thinks that ribosomes always translate messenger RNA in a triplet-wise manner. It also contains a nice discussion of pseudoknot-dependent frameshifting and readthrough.

34. Herold J, Siddell SG: An 'Elaborated' Pseudoknot is Required for High Frequency Frameshifting During Translation of HCV 229E Polymerase mRNA. *Nucleic Acids Res* 1993, 21:5838–5842.

A nice example of how evidence is obtained for a pseudoknot as a stimulator in frameshifting. It also shows us that we always have to be aware of the existence of pseudoknots that are more complex than simply two stems and two (short) connecting loops.

35. Tu C, Tzeng T-H, Bruenn JA: Ribosomal Movement Impeded at a Pseudoknot Required for Frameshifting. *Proc Natl Acad Sci USA* 1992, 89:8636–8640.
36. Somogyi P, Jenner AJ, Brierley I, Inglis SC: Ribosomal Pausing During Translation of an RNA Pseudoknot. *Mol Cell Biol* 1993, 13:6931–6940.

Many people in the field of frameshifting and readthrough explain the function of pseudoknots in terms of ribosomal pausing. Together with [35], this paper provides actual evidence in support of this.

37. Garcia A, van Duin J, Pleij CWA: Differential Response to Frameshift Signals in Eukaryotic and Prokaryotic Translational Systems. *Nucleic Acids Res* 1993, 21:401–406.
38. Kujawa AB, Dugeon G, Hulanicka D, Haenni A-L: Structural Requirements for Efficient Frameshifting in the Synthesis of the Putative Viral RNA-dependent RNA Polymerase of Potato Leafroll Virus. *Nucleic Acids Res* 1993, 21:2165–2171.
39. Prüfer D, Tacke E, Schmitz J, Kull B, Kaufmann A, Rohde W: Ribosomal Frameshifting in Plants: a Novel Signal Directs the –1 Frameshift in the Synthesis of the Putative Viral Replicase of Potato Leafroll Luteovirus. *EMBO J* 1992, 11:1111–1117.
40. Perrotta A, Been MD: Assessment of Disparate Structural Features in Three Models of the Hepatitis Delta Virus Ribozyme. *Nucleic Acids Res* 1993, 21:3959–3965.
41. Kumar PKR, Taira K, Nishikawa, S: Chemical Probing Studies of Variants of the Genomic Hepatitis Delta Virus Ribozyme by Primer Extension Analysis. *Biochemistry* 1994, 33:583–592.
42. Suh Y-A, Kumar PKR, Kawakami J, Nishikawa F, Taira K, Nishikawa S: Systematic Substitution of Individual Bases in Two Important Single-Stranded Regions of the HDV Ribozyme for Evaluation of the Role of Specific Bases. *FEBS Lett* 1993, 326:158–162.
43. Wu H-N, Lee J-Y, Huang H-W, Huang Y-s, Hsueh T-G: Mutagenesis Analysis of a Hepatitis Delta Virus Genomic Ribozyme. *Nucleic Acids Res* 1993, 21:4193–4199.
44. Tuerk C, MacDougal S, Gold L: RNA Pseudoknots that Inhibit Immunodeficiency Virus Type 1 Reverse Transcriptase. *Proc Natl Acad Sci USA* 1992, 89:6988–6992.

The identification of pseudoknotted structures as the winning structural motif for binding to the reverse transcriptase has wide implications for the way in which we have to appreciate pseudoknotted structures. Apparently, RNA pseudoknots are ideal structures for protein binding. I bet that loop L2, spanning the minor groove and probably having its base residues exposed, is in fact doing the trick. Pseudoknot formation is probably one of the few ways to destack or expose a stretch of base residues.

45. Gold L, Allen P, Binkley J, Brown D, Schneider D, Eddy SR, Tuerk C, Green L, MacDougal S, Tasset D: RNA: The Shape of Things to Come. In *RNA World*. Edited by Gestland RF, Atkins JF. Cold Spring Harbor: Cold Spring Harbor Laboratory Press; 1993:497–509.

CWA Pleij, Leiden Institute of Chemistry, Gorlaeus Laboratories, Leiden University, PO Box 9502, 2300 RA, Leiden, The Netherlands.