

AzeR, a transcriptional regulator that responds to azelaic acid in *Pseudomonas nitroreducens*

Cristina Bez^{1†}, Sree Gowrinadh Javvadi^{1†}, Iris Bertani¹, Giulia Devescovi¹, Corrado Guarnaccia¹, David J. Studholme², Alexander M. Geller³, Asaf Levy³ and Vittorio Venturi^{1,*}

Abstract

Azelaic acid is a dicarboxylic acid that has recently been shown to play a role in plant-bacteria signalling and also occurs naturally in several cereals. Several bacteria have been reported to be able to utilize azelaic acid as a unique source of carbon and energy, including *Pseudomonas nitroreducens*. In this study, we utilize *P. nitroreducens* as a model organism to study bacterial degradation of and response to azelaic acid. We report genetic evidence of azelaic acid degradation and the identification of a transcriptional regulator that responds to azelaic acid in *P. nitroreducens* DSM 9128. Three mutants possessing transposons in genes of an acyl-CoA ligase, an acyl-CoA dehydrogenase and an isocitrate lyase display a deficient ability in growing in azelaic acid. Studies on transcriptional regulation of these genes resulted in the identification of an IclR family repressor that we designated as AzeR, which specifically responds to azelaic acid. A bioinformatics survey reveals that AzeR is confined to a few proteobacterial genera that are likely to be able to degrade and utilize azelaic acid as the sole source of carbon and energy.

INTRODUCTION

Bacteria of the plant microbiome are exposed to many plant-derived compounds that are likely to play important roles in plant-bacteria communication and facilitate bacterial growth and colonization of plant niches. For example, lipid-derived molecules of both microbes and plants have recently been shown to play a role as signals for plant-bacteria communication [1, 2]. In addition, fatty acids are also the precursors for the synthesis of compounds involved in intracellular plant signalling including jasmonic and azelaic acids, which are part of the cascade that triggers systemic defences [1].

Azelaic acid (Fig. 1a) is a straight chained nine-carbon (C₉) saturated dicarboxylic acid that occurs naturally in whole-grain cereals, rye and barley [3]. Azelaic acid in plants is derived from lipids via lipid peroxidation and primes systemic defence in *Arabidopsis*, suggesting that this mobile molecule can move systemically, most likely through the plant vasculature, and contribute to long-distance signalling in plant defence against pathogens. Azelaic acid specifically promotes disease resistance by priming salicylic acid (SA) signalling as part of systemic plant immunity [4, 5]. Recently,

plant-associated *Pseudomonas syringae* pathovars have been reported to most likely produce azelaic acid, hinting a role in plant-bacteria communication [6]. In soil, azelaic acid along with other short-chain fatty acids are considered the products of microbial enzymatic oxidation of unsaturated lipids and aromatic hydrocarbons [7]. Several reports have shown that bacteria such as *Acinetobacter* spp., *P. fluorescens* and *P. aeruginosa* are capable of degrading dicarboxylic acids and utilizing them as their sole carbon source [8, 9]. Established work reported the isolation and identification of a *Pseudomonas* strain that can very efficiently degrade azelaic acid and utilize it as the sole source of carbon and energy [10, 11]. The bacterial isolate was classified as *Pseudomonas azelaica* DSM 9128 and later reclassified as *P. nitroreducens* [12].

Initial experiments from Janota–Bassalik and Wright using *P. nitroreducens* DSM 9128 [10, 11] support the hypothesis that the trait of degrading the azelaic acid is a consequence of β -oxidation steps analogous to those of fatty acid degradation. Due to its possible role in plant-bacteria communication, it was of interest to isolate a bacterial regulator that can respond to the presence of azelaic acid and determine its presence in plant-associated bacteria. In this study, we report genetic

Received 01 July 2019; Accepted 07 October 2019; Published 17 October 2019

Author affiliations: ¹International Centre for Genetic Engineering and Biotechnology, Padriciano 99, 34149 Trieste, Italy; ²Biosciences, University of Exeter, Stocker Road, Exeter EX4 4QD, UK; ³Department of Plant Pathology and Microbiology, The Robert H. Smith Faculty of Agriculture, Food, and Environment, The Hebrew University of Jerusalem, POB 12 Rehovot 761001, Israel.

*Correspondence: Vittorio Venturi, vittorio.venturi@icgeb.org

Keywords: Bacteria; Gene regulation; azelaic acid; pseudomonas.

Abbreviations: AZ, azelaic acid; GLU, glucose.

†These authors contributed equally to this work

000865 © 2020 The Authors



This is an open-access article distributed under the terms of the Creative Commons Attribution NonCommercial License.

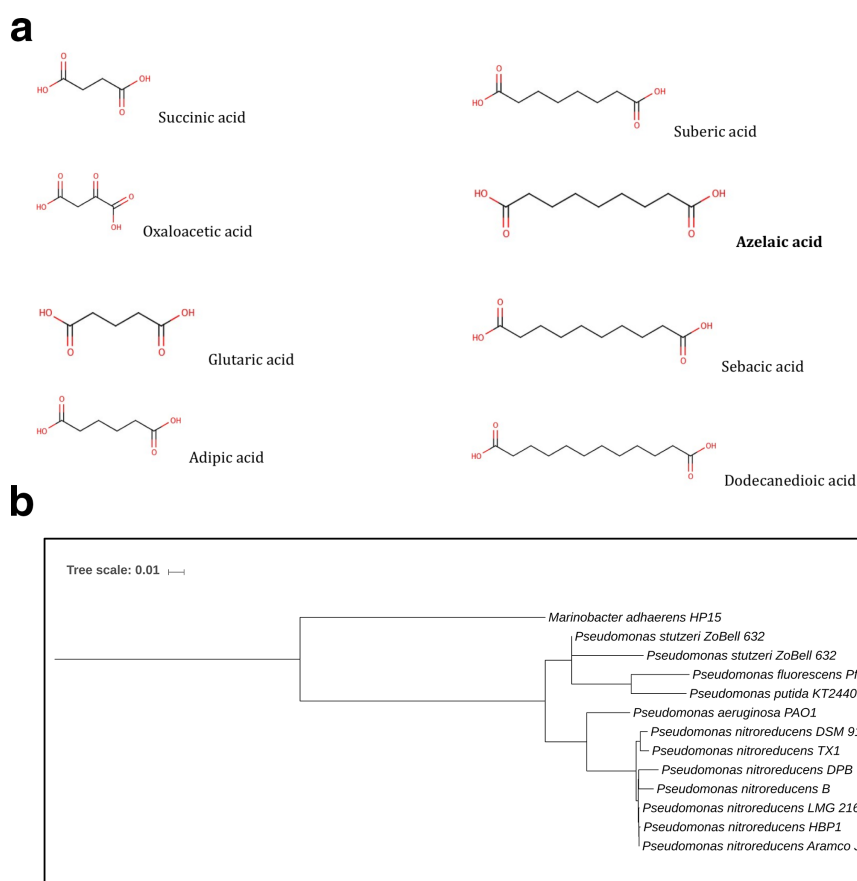

Fig. 1. Structure of dicarboxylic acids and *P. nitroreducens* DSM 9128 phylogenetic tree. (a) Structure of dicarboxylic acids used in this study. (b) Phylogenetic tree showing the phylogenetic position of *P. nitroreducens* strain DSM9128 based on evolutionary distance of concatenated COGs listed in Table 3. Included in the tree are *Pseudomonas* and *Marinobacter* species, which have a homologue of AzeR (see text).

evidence of azelaic acid degradation and the identification of a transcriptional regulator that responds to azelaic acid in *P. nitroreducens* DSM 9128. Three mutants possessing transposon insertions in genes of acyl-CoA ligase, of acyl-CoA dehydrogenase and in an isocitrate lyase display a growth deficiency in the presence of azelaic acid. Studies on transcriptional regulation of these genes resulted in the identification of a IclR family repressor that we designated as AzeR that specifically responds to azelaic acid. AzeR is widespread in *Pseudomonas* and *Marinobacter* species.

METHODS

Bacterial strains, constructs, media and growth conditions

P. nitroreducens and *Escherichia coli* strains DH5 α [13], CC118 [14] and HB101 [15] were routinely grown at 28 and 37 °C respectively, in Luria–Bertani broth/agar medium [16] or in defined M9 minimal medium [15]. All plasmid constructs used in this study are listed in Table 1. When azelaic acid was used as the carbon source, it was added to the growth medium

at a final concentration of 0.1–0.2% (5–10 mM). The following antibiotic concentrations were used: ampicillin (Amp) 100 $\mu\text{g ml}^{-1}$, kanamycin (Km) 100 $\mu\text{g ml}^{-1}$, gentamicin (Gm) 50 $\mu\text{g ml}^{-1}$, tetracycline (Tc) 40 $\mu\text{g ml}^{-1}$, nalidixic (Nx) 25 $\mu\text{g ml}^{-1}$ and nitrofurantoin (Nf) 50 $\mu\text{g ml}^{-1}$ for *P. nitroreducens* and Amp100 $\mu\text{g ml}^{-1}$, Km50 $\mu\text{g ml}^{-1}$, Gm 15 $\mu\text{g ml}^{-1}$ and Tc 15 $\mu\text{g ml}^{-1}$ for *E. coli* strains.

Recombinant DNA techniques

DNA manipulations, including digestion with restriction enzymes, agarose gel electrophoresis, purification of DNA fragments, ligation with T4 DNA ligase, transformation of *E. coli*, colony hybridization and radioactive labelling by random priming, were performed as previously described [15]. Southern hybridizations were performed using Hybond-N+membrane (Amersham Pharmacia Biotech). Plasmids were purified using EuroClone columns (EuroClone S.p.A., Italy). Total DNA from *P. nitroreducens* was isolated with the sarkosyl-pronase lysis method Better *et al.* [17]. Triparental matings to mobilize DNA from *E. coli* to *P. nitroreducens* were

Table 1. Plasmids used in this study

Plasmids	Characteristics	References
pGem T-Easy	Cloning vector; Amp ^R <i>LacZ</i> reporter	(Promega)
pBluescript II KS	Cloning vector; Amp ^R <i>LacZ</i> reporter, sito polylinker, da pUC19	(Stratagene)
pLAFR3	Broad-host-range cosmid cloning vector, IncP1; Tet ^r	[37]
pMP220	Promoter probe vector, IncQ; Tet ^R	[38]
pKNOCK- Km	Conjugative suicide vector; Km ^R	[14]
pCRS530	pAB2001 derivative containing CAS-GNm with flanking region NotI-HindIII-EcoRI-SmaI; Ap ^r , Km ^r	[19]
pRK2013	helper triparental conjugation, Km ^r	[18]
pCos1	pLAFR3 carrying <i>P. nitroreducens</i> DSM 9128 genomic DNA	This study
pCos 5	pLAFR3 carrying <i>P. nitroreducens</i> DSM 9128 genomic DNA	This study
pCos G	pLAFR3 carrying <i>P. nitroreducens</i> DSM 9128 genomic DNA	This study
pCos M	pLAFR3 carrying <i>P. nitroreducens</i> DSM 9128 genomic DNA	This study
pKnReg	Internal PCR fragment of <i>P. nitroreducens</i> DSM 9128 <i>azeR</i> cloned in Pknock-Km	This study
pMPReg	Promoter of transcriptional regulator gene cloned in pMP220 vector	This study
pMPLig	Promoter of Acyl-CoA ligase cloned in pMP220 vector	This study
pMPDeh	Promoter of Acyl-CoA dehydrogenase cloned in pMP220 vector	This study
pMPIsocit	Promoter of Isocitrate lyase cloned in pMP220 vector	This study

carried out with the helper strain *E. coli* (pRK2013) [18]. PCR amplifications were performed on *P. nitroreducens* genomic DNA using GoTaq Flexi DNA Polymerase (Promega, Madison, WI, USA) and the automated sequencing was performed by GATC-Biotech services (Kostanz, Germany). The oligonucleotide primers used in this study are listed in Table 2.

Construction of genomic transposon mutant bank and isolation of mutants unable to use azelaic acid as the carbon source

Plasmid pCRS530 [19] carrying the mTn5-GNm (containing *gusA*-P_{lac}-*nptII*-T_{trpA}) was harboured in *E. coli* S17-1 [20] and biparental conjugation was performed in order to conjugate this plasmid into *P. nitroreducens* DSM 9128. The *P. nitroreducens* strains harbouring the mTn5-GNm into the chromosome were selected on Luria–Bertani agar plates containing Km, Nf and Nx and incubated for 18 h at 28 °C. Several conjugations were performed in order to obtain approximately 30000 independent transposon insertions. Among these, 5000 mutants were screened for inability to grow on azelaic acid as the unique source of carbon and energy as follows: purified colonies from the mTn5-GNm genomic mutant bank were individually hand-picked and grown at 28 °C in replicate on minimal M9 plates containing glucose or azelaic acid (0.1%). Six *P. nitroreducens* DSM 9128 transposon mutants were selected, which were unable or could very poorly grow on azelaic acid as the sole carbon source, but retaining the ability

to grow on glucose. Their azelaic acid utilization inability was confirmed by growth-curve studies.

Mapping of transposon insertion sites and complementation of genomic mutants

The DNA sequence-flanking transposon mutants in *P. nitroreducens* DSM 9128 were determined using an arbitrary PCR procedure, as previously described [21]. In this method, the DNA flanking the transposon insertion site was enriched in two rounds of amplification using primers specific to the ends of the mTn5-GNm element and primers of random sequence that annealed to chromosomal sequences flanking the transposon (for primers see Table 2). For mutants 9128E, 9128I, 9128F and 9128M the arbitrary PCR did not work and in order to identify/clone the chromosomal DNA flanking the transposon, digestion of genomic DNA was performed using restriction enzymes that do not recognize the DNA sequence of the transposon. Sequences obtained were subjected to homology searches using a local NCBI BLAST and also with the draft genome sequence of *P. nitroreducens* DSM 9128 using a local BLAST algorithm confirming the genomic location of the mutants.

The mutants selected were complemented for their defective growth as follows: a genomic bank (cosmid library) of *P. nitroreducens* DSM 9128 was constructed from a partial *EcoRI* digested *P. nitroreducens* DSM 9128 genomic DNA and ligated into *EcoRI* digested cosmid pLAFR3. The

Table 2. Primers used in this study

Primer name	Sequence of primer	References
Tn5ext	5'-TATTGCTGAAGAGCTTGGC-3'	This study
ARB1	5'-GGCCACGCGTCGACTAGTACNNNNNNNNNN-3'	[21]
Tn5int	5'-GCATCGCCTTCTATCGCCTC-3'	This study
ARB2	5'-GGCCACGCGTCGACTAGTAC-3'	[21]
prMutS1	5'-TATCAAAACGACATCAAAGCCGTTGC-3'	This study
prMutS2	5'-TTAGTGGAAGTGGTTCATGGTGT-3'	This study
prMutD1	5'-ATGCCCGCTCAACCGACC-3'	This study
prMutD2	5'-TCACGGGGTCTTCT-3'	This study
prRegBam	5'-AGGATCCGGAGGGTTGAGCAGACAT-3'	This study
prRegEco	5'-AGAATTCGCGTGTGCTCGTTGCG-3'	This study
prLigBam	5'-AGGATCCTTGGGGTTGCTGCTGTCT-3'	This study
prLigEco	5'-AGAATTCGAGGGTTGAGCAGACAT-3'	This study
prIsocitBam	5'-AGGATCCAGAACGGTTTCGCCCG-3'	This study
prIsocitEco	5'-AGAATTCCTTTCAGAGCGGCAACGG-3'	This study
KnRegXho	5'-ACTCGAGGAAATCTCGGGATCACCG-3'	This study
KnRegXba	5'-ATCTAGATCATCGACAGCCAGTCACGG-3'	This study
prDehEco	5'-AGAATTCACCGGTGGGTGTGCGACT-3'	This study
prDehBam	5'-AGGATCCGCCAGCAACTGGTGT-3'	This study
Δ Reg mut	5'-ATCACCGACCAATCGCCTTCG-3'	This study
prRegSensBam	5'-AGGATCCGAGCAGCGATCCAG-3'	This study

concatameric constructs obtained were then packaged in phage lambda and transfected into *E. coli* HB101 cells using Gigapack III XL-4 packaging kit as recommended by the supplier (Stratagene-Agilent, Santa Clara, CA, USA). The genomic cosmid bank (7500 clones) was then screened for the gene of interest by hybridization with labelled DNA probes via colony blot hybridization and then verified by Southern analysis. Triparental matings between the *E. coli* HB1010 harbouring the cosmids selected were then conjugated into *P. nitroreducens* using *E. coli* (pRK2013) as the helper strain.

Construction of the *azeR* mutant in *P. nitroreducens*

The *azeR* gene was inactivated in *P. nitroreducens* by amplifying via PCR an internal fragment of this gene using primers KnRegXho, KnRegXba listed in Table 2, cloning it in pKNOCK-Km [14] and then using it as a suicide plasmid via conjugation into *P. nitroreducens* and selecting for insertion into the chromosome via homologous recombination. Km-resistant colonies were selected and the mutation of the targeted gene was confirmed by PCR.

Construction of plasmid gene promoter transcriptional fusions and β -galactosidase assays

Transcriptional gene promoter activity studies of four promoters were performed in *P. nitroreducens*. All constructs were made in the promoter probe vector pMP220 (Tc^R); this is a plasmid which carries a promoterless *lacZ* gene and harbours the gene for tetracycline resistance. The four gene promoter regions were amplified from *P. nitroreducens* DSM 9128 genomic DNA by using the primers listed in Table 2. The PCR amplified fragments were first cloned in pGEM-T Easy vector (Promega, Madison, WI, USA), sequenced and then excised as *EcoRI*/*Bam*HI fragments and cloned into the *Bgl*II/*EcoRI* sites in pMP220 obtaining pMPLig, pMPDeh, pMPIsocit, pMPReg. The constructs obtained are listed in Table 1.

β -galactosidase activities were determined essentially as described by Miller [16], with the modifications of Stachel *et al.* [22]. Each experiment was performed in triplicate. Gene promoter activity was determined by monitoring β -galactosidase activity in overnight cultures.

Draft genome sequence of *P. nitroreducens* DSM 9128.

The genome sequence of *P. nitroreducens* was determined using a 250 bp paired-end library with the Illumina MiSeq sequencing system (University of Exeter Sequencing Service, Exeter, UK), which generated a total of 1611521 pairs of reads. Reads were assembled using SPAdes 3.9.03 [23] and the assembled sequence annotated using the NCBI Prokaryotic Genome Annotation Pipeline (PGAP). The *P. nitroreducens* DSM 9128 genome was also uploaded to the Integrated Microbial Genomes and Metagenomes (IMG/M) database and was automatically annotated using annotation pipeline IMG Annotation Pipeline v.4.16.6 [24]. The IMG genome ID is 2818991220.

Phylogenomics and AzeR homology analysis

The amino acid sequence of AzeR of *P. nitroreducens* DSM 9128 was queried by a BLAST search against all genomes in the US Department of Energy IGM/M database. All hits with greater than 60% amino acid sequence identity were considered matches, and the species associated with each protein were taken for further comparison ($n=192$). Overall, our methodology compared sequence variation of 30 COGs (Clusters of Orthologous Genes) that are considered universal single-copy genes [25] to calculate the evolutionary distance between the species. Of the 192 species matches to AzeR, poor-quality genomes that were missing universal COGs as well as those with more than one copy of COG genes were removed from the analysis, with a final list of 143 genomes continuing in the pipeline. The COGs from each species were aligned using Clustal Omega, with FASTA-formatted output. Each alignment was trimmed using TrimAl v1.3 [26] using the 'automated1' flag. The COGs from each species were concatenated, all in the same order. These 143 sequences were inputted into fasttree 2.1.10 [27] using standard settings. The outputted tree was visualized using Interactive Tree of Life [28]. *E. coli* K12 MG1655 served as an outgroup. The same analysis was performed for comparison of relatives of *P. nitroreducens*, using the marked COGs indicated in Table 3.

Nucleotide sequence accession numbers

This whole-genome shotgun project of the *P. nitroreducens* genome has been deposited at DDBJ/EMBL/GenBank under the accession number VASG00000000. Sequence reads are available in the Sequence Read Archive under accession number SRR9041312.

RESULTS

Draft genome sequence of *P. nitroreducens* DSM 9128

In order to begin to study the possible regulatory response in bacteria to azelaic acid, the genome of *P. nitroreducens* DSM 9128 was sequenced, since this strain was isolated and reported as being able to efficiently degrade and utilize azelaic acid as the sole carbon and energy source [10, 11]. We obtained a total of 1611521 pairs of reads, which we assembled into 15

Table 3. COGs used for *P. nitroreducens* phylogenomics and AzeR phylogenetic tree

COG0012*
COG0016
COG0018
COG0049*
COG0052*
COG0080*
COG0081
COG0087*
COG0088*
COG0090*
COG0092*
COG0093*
COG0094*
COG0096*
COG0097*
COG0098*
COG0103*
COG0124
COG0172
COG0185*
COG0186*
COG0197*
COG0200*
COG0201*
COG0202*
COG0215
COG0256*
COG0495*
COG0522*
COG0525*

Those with a star *were used for Fig. 1. All COGs in this table were used for Fig. 6.

contigs with a total length of 6707527 bp and an N_{50} length of 782887. The G+C content was 65.5%, similar to that of other sequenced *Pseudomonas* genomes. Automated annotation of the *P. nitroreducens* draft genome sequence assigned a total of 6055 candidate protein-coding genes. A total of 6 rRNA and 60 tRNA genes were also identified. The phylogenetic analysis (Fig. 1b) showed that the strain of *P. nitroreducens* DSM 9128 is most closely related to other strains of *P. nitroreducens* spp.

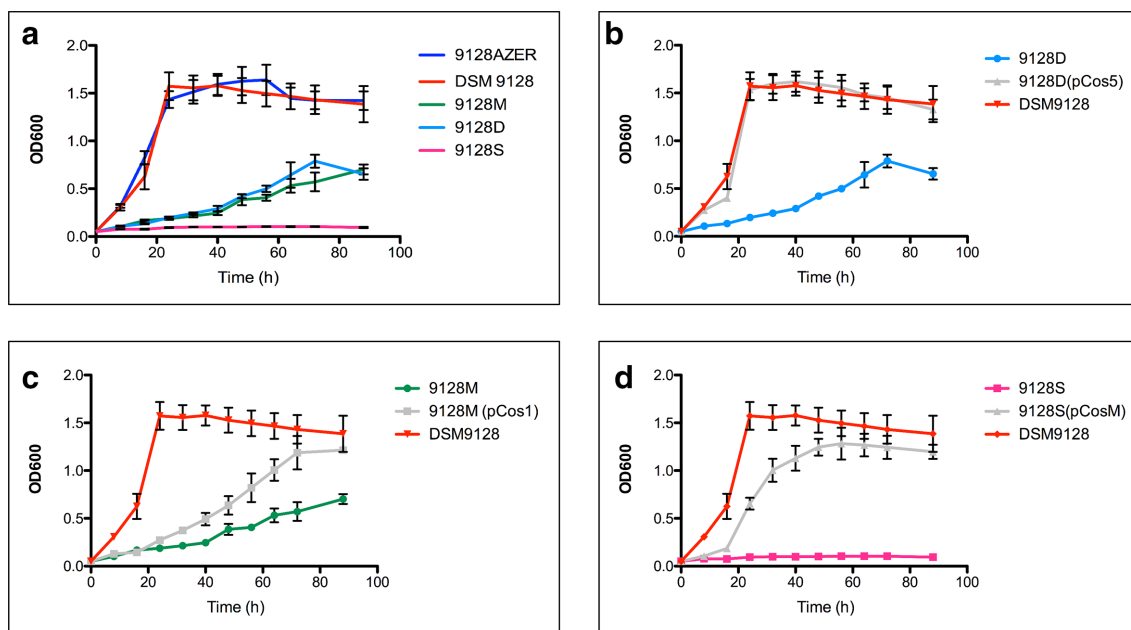

Fig. 2. Growth rates of *P. nitroreducens* DSM 9128 and mutant derivatives. (a) Growth rates of *P. nitroreducens* DSM 9128 and mutant derivatives 9128M, 9128D, 9128S and 9128AZER grown in M9 minimal media with azelaic acid 0.2% as the unique source of carbon and energy. (b) Growth rates of *P. nitroreducens* DSM 9128 and mutant derivative 9128D and 9128D (pCos5) grown in M9 minimal media with azelaic acid 0.2% as the unique source of carbon and energy. (c) Growth rates of *P. nitroreducens* DSM 9128 and mutant derivative 9128M and 9128M (pCos1) grown in M9 minimal media with azelaic acid 0.2% as the unique source of carbon and energy. (d) Growth rates of *P. nitroreducens* DSM 9128 and mutant derivative 9128S and 9128S (pCosM) grown in M9 minimal media with azelaic acid 0.2% as the unique source of carbon and energy.

such as *P. nitroreducens* strain TX1, which was isolated from a rice field's recycle drainage, and has the ability to metabolize industrial surfactants that pollute aquatic environments [29].

Isolation and identification of genomic transposon mutants affected in azelaic acid degradation in *P. nitroreducens* DSM 9128

We confirmed that *P. nitroreducens* strain DSM 9128 can utilize azelaic acid as the sole carbon source since it could grow well in M9 minimal medium supplemented with 0.2% w/v of azelaic acid as the unique source of carbon and energy. In order to identify the regulatory mechanism(s) in response to azelaic acid a *P. nitroreducens* transposon mutant bank was constructed and screened for inability to grow on azelaic acid. In total, 5000 transposon mutants of *P. nitroreducens* DSM 9128 were screened on solid media for their ability to grow on azelaic acid. Six mutants, designated 9128D, 9128E, 9128F, 9128I, 9128M, 9128S, which could not grow on minimal media with azelaic acid but grew on glucose as the sole carbon source were isolated. Mutants 9128S, 9128E, 9128I, and 9128F displayed a complete lack of growth phenotype whereas 9128D and 9128M were characterized by very slow growth compared to the wild-type strain. Growth curves were determined for mutants 9128M, 9128D and 9128S, which represent the three different classes along with the wild-type strain and the results show significant differences in growth (Fig. 2a). It was therefore concluded that the identified

mutants most likely had transposon insertions in loci, which were involved in the utilization of azelaic acid as the unique source for carbon in *P. nitroreducens* 9128.

Characterization of the six transposon genomic mutants of *P. nitroreducens* DSM 9128 affected in azelaic acid utilization

In order to identify the genes in the transposon insertion mutants that were defective in azelaic acid utilization, the location of the transposon in the mutants was mapped. Mutant 9128D had the transposon inserted in a gene encoding for an acyl-CoA ligase for long-chain fatty acids whereas mutant 9128S had the insertion in the isocitrate lyase gene (Fig. 3). Mutants 9128E, 9128F, 9128I and 9128S carried the transposon in an isocitrate lyase gene but in different positions within its nucleotide sequence thus representing independent insertion mutants and strengthening the association of this gene with azelaic acid utilization. The transposon in the mutant 9128M was located in a locus encoding an acyl-CoA dehydrogenase, which was genetically adjacent to the acyl-CoA ligase, which had the transposon insertion of mutant 9128D (Fig. 3b). The acyl-CoA dehydrogenase is part of an operon of three genes and the acyl-CoA ligase is part of an operon with the enoyl-CoA hydratase. The two operons are separated by a transcriptional regulator that belongs to the IclR family (Fig. 3, designated as AzeR).

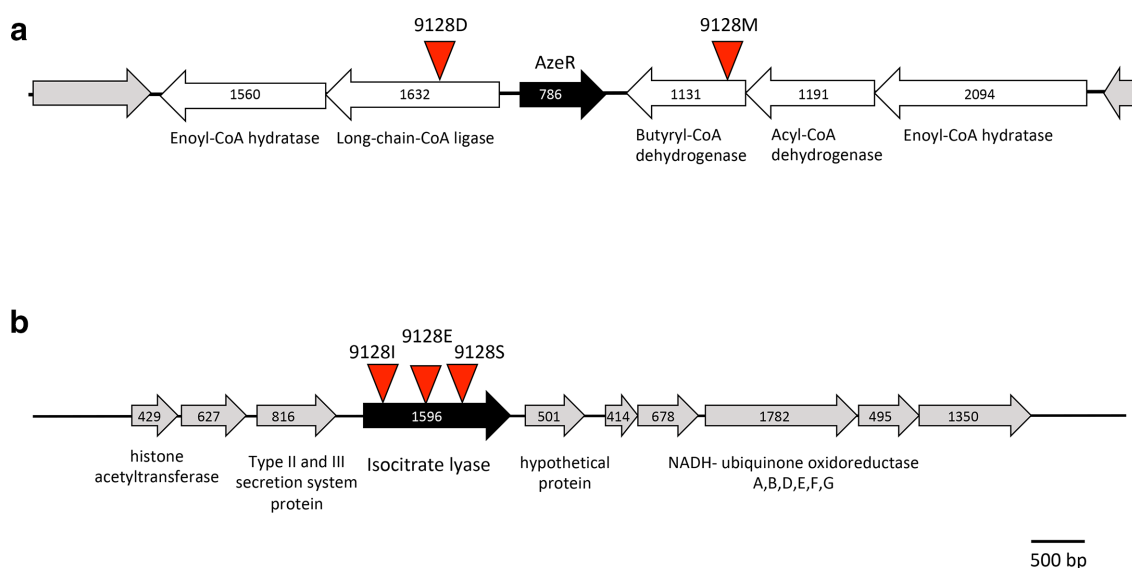

Fig. 3. Map of genetic loci harbouring the Tn5 mutations of the identified mutants. (a) Genetic locus harbouring the Tn5 mutants 9128D and 9128M, which were affected in growth in azelaic acid as the unique source of carbon. The position of the Tn5 is shown by a red triangle, the positions of the ORFs are shown and the encoding gene product is described below the open arrows. The AzeR IclR-family transcriptional regulator is indicated by a black-filled arrow. (b) Genetic locus harbouring the Tn5 mutants 9128E, 9128I and 9128S, which were affected in growth in azelaic acid as the unique source of carbon. The position of the Tn5 is shown by a red triangle, the positions of the ORFs are shown and the encoding gene product is described below the open arrows.

Next, we tried to complement the mutations. A pLAFR3 cosmid genomic library of *P. nitroreducens* DSM9128 was constructed as described in Methods. The cosmid colonies harboured in *E. coli* were then hybridized with a labelled DNA probe of the *iclR* regulatory gene located in between the two operons and four cosmids were identified and designated pCos1, pCos5, pCosM and pCosG, which contained the genomic loci harbouring the genes of interest.

It was then determined that pCos5 complemented the defect of growth phenotype on azelaic acid displayed by the acyl-CoA ligase 9128D mutant (Fig. 2b); pCos1 and pCos5 could significantly complement ($P < 0.001$) the acyl-CoA dehydrogenase 9128M (Fig. 2c) mutant and pCosM complemented the isocitrate lyase mutant 9128S (Fig. 2d). It was therefore concluded that the phenotypes observed by the transposon mutants were due to the loci in which the insertion occurred.

AzeR is an IclR family repressor that responds to azelaic acid

The main aim of this work was to study the regulation of genes in response to azelaic acid. The gene promoters regulating the transcription of the operons harbouring the acyl-CoA ligase and acyl-CoA dehydrogenase and the gene promoter of the isocitrate lyase were cloned in a promoter probe vector, which harboured a promoterless β -galactosidase (*lacZ*) gene. *P. nitroreducens* DSM9128 harbouring the plasmids constructs were assayed for promoter activity and it was established that the presence of 0.1% w/v of azelaic acid dramatically induced the transcription from the promoters controlling the expression of the operons containing the acyl-CoA dehydrogenase and of

the acyl-CoA ligase (Fig. 4a and b). If other very closely related dicarboxylic acids were used instead, like suberic, sebacic and adipic acid (Fig. 1a), no activation of the two promoters was observed indicating that the response was specific for azelaic acid (Fig. 5a). Intergenically located between the operons, which harbour two loci identified in this study, is a locus encoding a putative *iclR* family transcriptional regulator (Fig. 3a); it was therefore postulated that this regulator, which we designated as AzeR, might play a role in their regulation. A genomic knock-out mutant of this regulator was constructed, which we designated as strain 9128AZER. The gene promoter assays were then performed in the wild-type strain and the *P. nitroreducens* 9128AZER establishing that the two promoters displayed significantly high constitutive expression even in the absence of azelaic acid (Fig. 4a and b). It was therefore concluded that AzeR behaved as a negative transcriptional regulator, which dramatically de-repressed transcription of the two operons in the presence of azelaic acid. We also determined whether AzeR was autoregulating its own expression; gene promoter studies showed that it was negatively autoregulating its own transcription in response to azelaic acid (Fig. 4c). The isocitrate lyase promoter on the other hand did not respond to azelaic acid and it was active and constitutive in all the conditions tested (Fig. 4d). With the aim to understand at which concentration of azelaic acid the AzeR de-repressed the operon promoters, a calibration curve in response to different concentrations of azelaic acid was determined. The results obtained revealed that the genes involved in the azelaic acid degradation pathway were strongly regulated by the azelaic acid, starting from a concentration higher than 10 μ M (Fig. 5b).

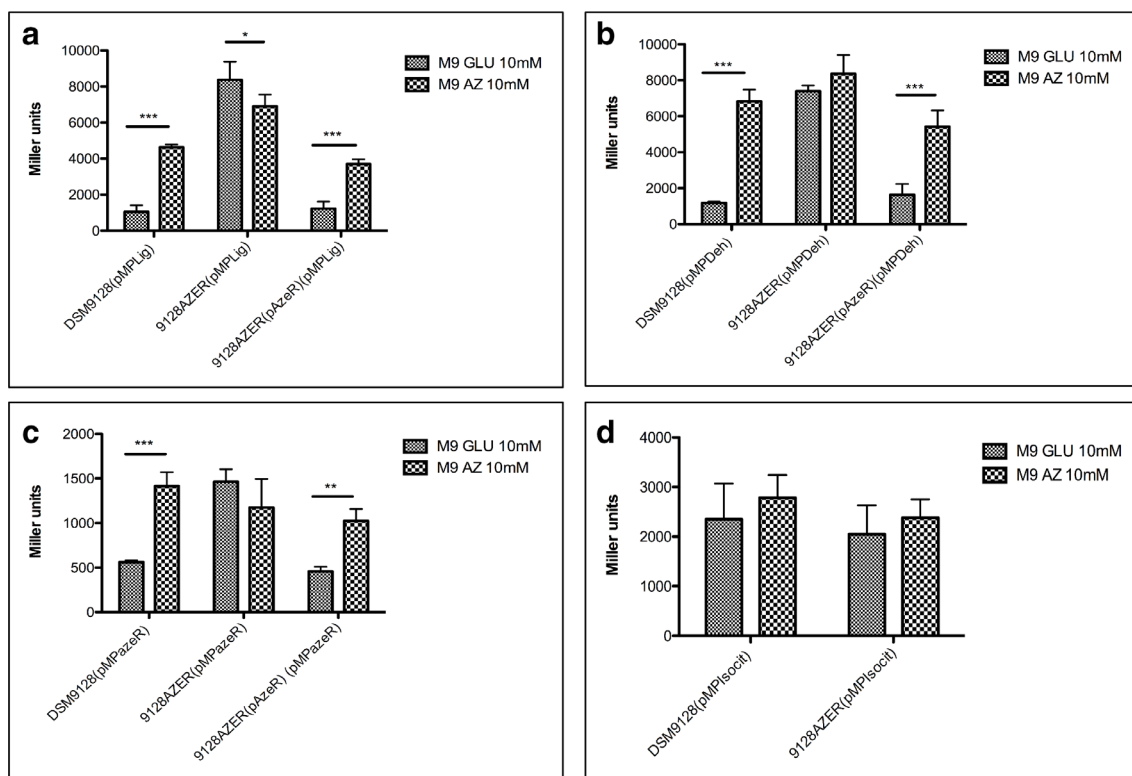

Fig. 4. Gene-promoter studies in *P. nitroreducens*. (a) β -galactosidase assays in *P. nitroreducens* DSM9128, 9128AZER and 9128AZER(pAzeR) harbouring the gene promoter regulating the transcription of the acyl-CoA ligase (inactivated by transposon 9128D) fused to a promoterless *lacZ* in plasmid construct pMPLig. All strains were grown in minimal M9 media contain either 0.2% glucose (M9 GLU) or azelaic acid (M9 AZ) as the unique source of carbon and energy. (b) β -galactosidase assays in *P. nitroreducens* DSM9128, 9128AZER and 9128AZER(pAzeR) harbouring the gene promoter regulating the transcription of the acyl-CoA dehydrogenase (inactivated by transposon 9128M) fused to a reportless *lacZ* in plasmid construct pMPDeh. All strains were grown in minimal M9 media containing either 0.2% glucose (M9 GLU) or azelaic acid (M9 AZ) as the unique source of carbon and energy. (c) β -galactosidase assays in *P. nitroreducens* DSM9128, 9128AZER and 9128AZER(pAzeR) harbouring the gene promoter regulating the transcription of the *azeR* regulator gene fused to a reportless *lacZ* in plasmid construct pMPazeR. All strains were grown in minimal M9 media containing either 0.2% glucose (M9 GLU) or azelaic acid (M9 AZ) as the unique source of carbon and energy. (d) β -galactosidase assays in *P. nitroreducens* DSM9128, 9128AZER and 9128AZER(pAzeR) harbouring the gene promoter regulating the transcription of the isocitrate lyase fused to a reportless *lacZ* in plasmid construct pMPIsocit. All strains were grown in minimal M9 media containing either 0.2% glucose (M9 GLU) or azelaic acid (M9 AZ) as the unique source of carbon and energy. The data are means of three repeats, error bars indicate standard deviation and *t*-test was performed (* P <0.05, ** P <0.01, *** P <0.001), using Prism 7 (GraphPad Software).

AzeR is a novel bacterial regulator

AzeR belongs to the IclR family of bacterial transcriptional regulators, which consists of both activators and repressors [30]. These regulators are approximately 250 amino acids long and possess two domains: a DNA-binding helix-turn-helix domain at their *N*-terminus and an effector/inducer domain at their *C*-terminus. IclR-family regulators have been implicated in the regulation of many different loci, which are involved in degradation of aromatic compounds, in the glyoxylate cycle, in multidrug resistance and in virulence [30]. In order to establish the presence of orthologues and homologues of AzeR in bacteria, the amino acid sequence was compared to available sequences in the databases. Fig. 6 depicts the highly similar proteins (>60%) in bacteria showing that although AzeR-like proteins occur almost exclusively in *Pseudomonas* species, they are also found in *Marinobacter* species. To our

knowledge, none of these proteins has yet been studied or their biological role reported making AzeR a new IclR-family regulator in bacteria. The *Pseudomonas* species that harbour an AzeR-like regulator are known to be able to degrade many compounds for their energy and carbon source and many are plant-associated. *Marinobacter* are gamma-Proteobacteria that live in seawater and have been isolated and studied for their ability to degrade hydrocarbons [31]. Moreover, azelaic acid is enriched in marine aerosols of high biological activity in the ocean vs. regions of low biological activity (Bikina *et al.* [32]). *Marinobacter* in these aquatic regions may be responding to azelaic acid through its AzeR regulon. AzeR therefore is confined to a few proteobacterial genera that are likely to be able to degrade and utilize azelaic acid as the sole source of carbon and energy.

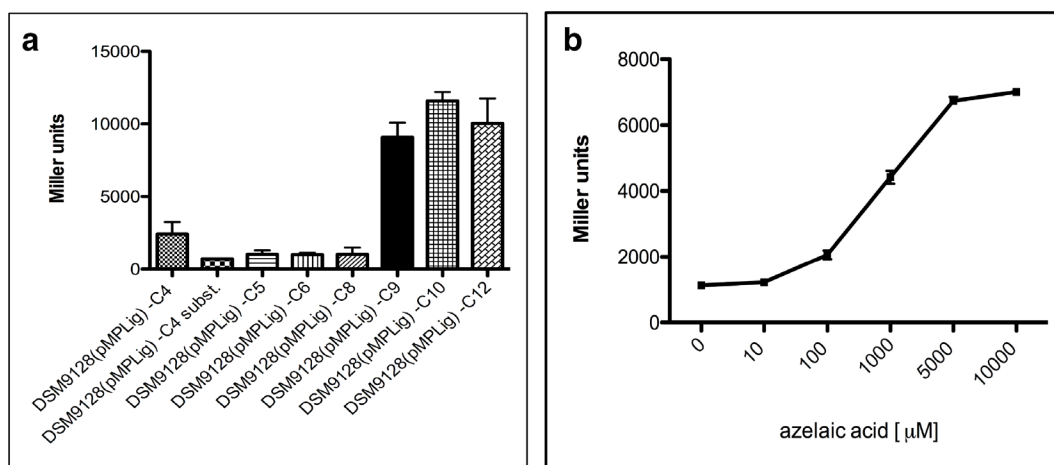

Fig. 5. Gene promoter studies in *P. nitroreducens* grown in the presence of different dicarboxylic acids. (a) β -galactosidase assays in *P. nitroreducens* DSM 9128 harbouring the gene promoter regulating the transcription of the acyl-CoA ligase (fused to a reportless *lacZ* in plasmid construct pMPLig) grown in minimal M9 medium in the presence of different dicarboxylic acids at a concentration of 0.2%; C4 is succinic acid, C4 subst. is oxaloacetic acid, C5 is glutaric acid, C6 is adipic acid, C8 is suberic acid, C9 is azelaic acid, C10 is sebacic acid and C12 is dodecanedioic acid. (b) β -galactosidase assays in *P. nitroreducens* DSM 9128 harboring the gene promoter regulating the transcription of the acyl-CoA ligase (inactivated by transposon 9128D) fused to a reportless *lacZ* in a plasmid construct pMPLig in M9 minimal medium with azelaic acid as the unique source of carbon and energy in different concentrations.

DISCUSSION

The bacterial strain *P. nitroreducens* DSM 9128 was used as a model for the study of genes necessary for the catabolism of azelaic acid. In bacteria, which utilize fatty acids as a carbon source, azelaic acid is relatively less preferred over other carbon sources [7]. A genetic screen using a genomic transposon library resulted in the identification of a set of mutants, which were unable, or significantly altered, in the ability to utilize azelaic acid as a unique source of carbon and energy. Mutants 9128D and 9128M (in an acyl-CoA ligase, an acyl-CoA dehydrogenase genes, respectively) that showed slow growth phenotype can possibly have mutated a functionally redundant gene for the degradation of azelaic acid. The total absence of growth on azelaic acid observed in mutants 9128S, 9128E, 9128I and 9128F, which are null mutants in an isocitrate lyase gene, indicated that the locus of the transposon insertion is absolutely necessary for this catabolic pathway.

The acyl-CoA ligase catalyses the pre-step reaction of β -oxidation by joining the acyl-CoA to the fatty acids that activates the breakdown of the molecule [33]. The acyl-CoA dehydrogenase enzyme on the other hand, catalyses the second step of β -oxidation of fatty acids and in particular transfers electrons from the substrate to the cofactor FAD in order to form a molecule of enoyl-CoA acting as a substrate for subsequent reactions [34]. Inactivation of these two genes in *P. nitroreducens* DSM 9128 results in the bacterium being significantly less efficient in the catabolism of azelaic acid (C9 dicarboxylic acid), as well as suberic acid (C8) and sebacic acid (C10). From *in silico* analysis it was observed that genes encoding for the acyl-CoA ligase and for the acyl-CoA dehydrogenase are part of a cluster of genes encoding for other enzymes in the pathway of β -oxidation (Fig. 3a).

Specifically, these genes are organized into two operons: one is composed of three genes, an enoyl-CoA hydratase, an acyl-CoA dehydrogenase and a long-chain fatty acid acyl-CoA dehydrogenase (this last locus identified and studied in this work) and the second one is composed of two genes, the long-chain fatty acid acyl-CoA ligase identified in this study and an enoyl-CoA hydratase. These two operons are separated by a nucleotide sequence encoding for a transcriptional regulator belonging to the IclR family.

Previous studies made in *E. coli* and in *Rhodopseudomonas palustris* suggest the presence in the genomes of these bacteria of a number of enzymes involved in β -fatty acid oxidation; some are organized in an operon called *fad* operon in *E. coli* and the *pim* operon in *R. palustris* [8, 35] both encoding for five enzymes involved in long and medium fatty acid degradation, reminiscent of the ones found in *P. nitroreducens* DSM 9128 reported here. The organization of the loci and the sequence of individual genes do not show however a particularly high homology.

An *iclR* family regulator is located adjacent to the two operons involved in azelaic acid degradation (see above). We established that this regulator in *P. nitroreducens*, which we designated as AzeR, is involved in the stringent negative regulation of the two adjacent operons in response to azelaic acid. As far as we know, this is the first transcriptional regulator responding to azelaic acid, an important molecule involved in plant-microbe interactions. The fact that it responds very poorly to other closely related dicarboxylic acids (Fig. 5) indicates that *P. nitroreducens* has evolved the ability to specifically respond to the presence of azelaic acid and via AzeR de-repress the transcription of the two operons

Tree scale: 0.1

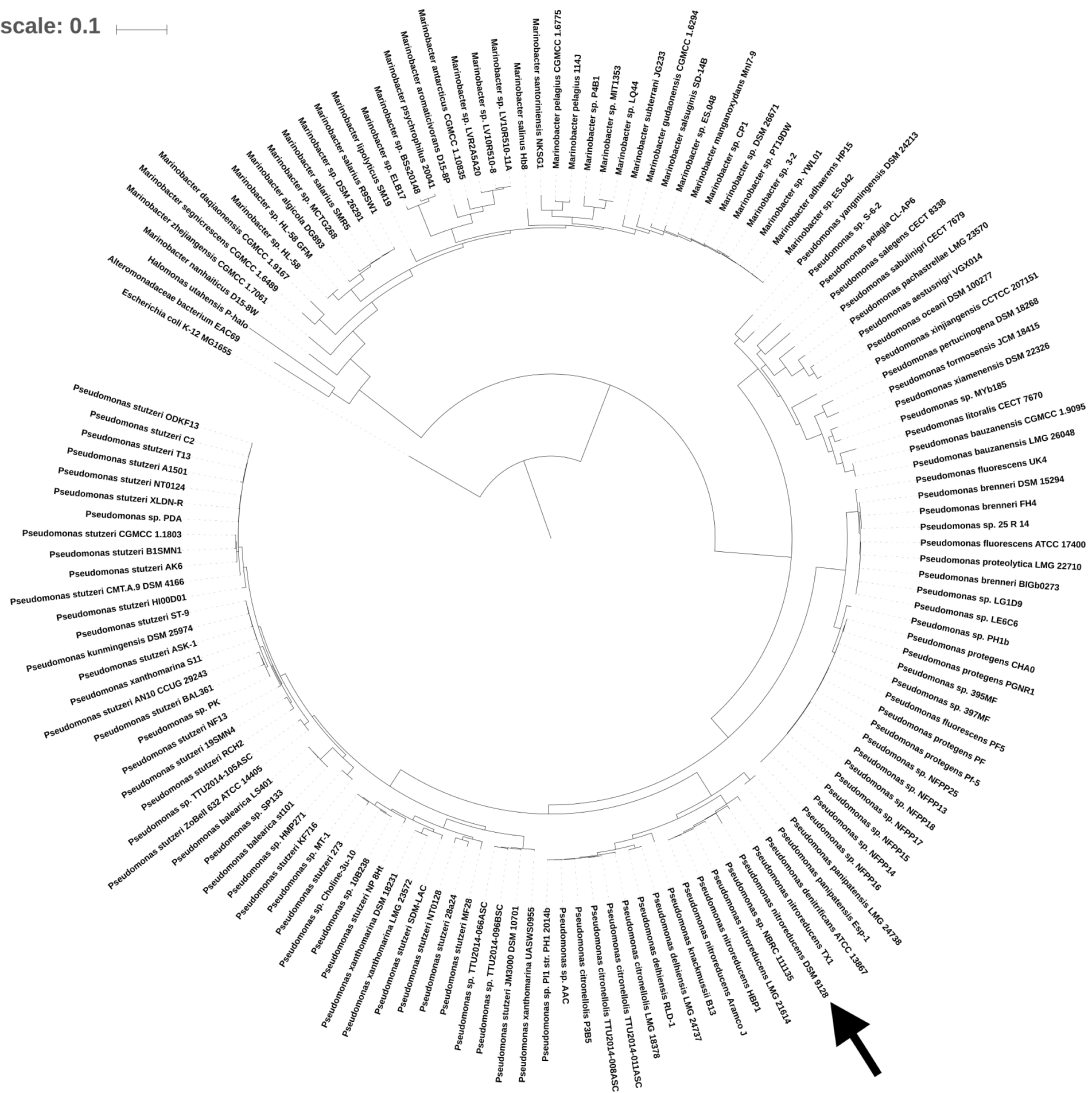

Fig. 6. AzeR homologies in other bacteria. Phylogenetic tree showing organisms with a strong (>60% amino acid sequence identity) AzeR homologue. The evolutionary distance between the organisms was determined using concatenated COGs listed in Table 3.

(Fig. 5). AzeR also negatively auto-regulates its own transcription in response to azelaic acid (Fig. 5); auto-regulation of transcription factors is a common trait in bacteria since it allows a more efficient response to the stimulus affecting the activity of the regulator. Interestingly AzeR homologues are only found in *Pseudomonas* (homology from 70–99%) and *Marinobacter* sp. (homology from 60–70%); it remains to be established if these species are able to utilize azelaic acid as the carbon source and if AzeR is the regulator which is responsible for the regulation of the genetic loci. The ability to respond to azelaic acid by these two genera indicates that they encounter it in the environment that they colonize. As AzeR is an IclR-family regulator, which specifically responds to azelaic acid and de-represses the transcriptional regulation, it is likely that it binds azelaic at its C-terminus and this results in AzeR being unable to bind to DNA through its helix-turn-helix N-terminus DNA-binding domain, thereby

allowing transcription of the target genes [30]. Biochemical and structural studies are needed to confirm this likely model of regulation by AzeR.

The isocitrate lyase mutant is characterized by the total lack of growth of *P. nitroreducens* with azelaic acid as the unique source of carbon and energy. This is an enzyme of the glyoxylate cycle, which acts within the TCA cycle allowing it to skip the last steps of the TCA cycle [36]. The growth on fatty acids requires the induction of this glyoxalate bypass since it prevents the loss of carbon as CO₂. The absolute requirement of isocitrate lyase indicates that azelaic degradation also occurs via the glyoxalate shunt. The isocitrate lyase is not regulated by AzeR or induced by the presence of azelaic acid and displayed constitutive expression during all the conditions tested in this study.

In summary, this study has revealed the presence of an IclR family repressor in bacteria, designated as AzeR, which responds to azelaic acid and de-represses transcription of two operons involved in the degradation of azelaic acid. AzeR is widespread only in *Pseudomonas* spp. and in *Marinebacter* indicating that these two genera have evolved the ability to sense the presence and respond to azelaic acid and regulate gene expression and this might be an important train in plant–microbe interaction.

Funding information

This work received no specific grant from any funding agency.

Acknowledgements

C.B. and S.G.J. are beneficiary of an ICGEB fellowship. We thank ICGEB for supporting this work. The bacterial *P. nitroreducens* strain DSM9128 sequenced in this work was obtained from the DSMZ collection and was isolated by Janot-Bassalik and Wright as cited in this work.

Conflicts of interest

The authors declare that there are no conflicts of interest.

References

- Shine MB, Xiao X, Kachroo P, Kachroo A. Signaling mechanisms underlying systemic acquired resistance to microbial pathogens. *Plant Sci* 2019;279:81–86.
- Siebers M, Brands M, Wewer V, Duan Y, Hölzl G et al. Lipids in plant-microbe interactions. *Biochim Biophys Acta* 2016;1861:1379–1395.
- Khakimov B, Jespersen BM, Engelsen SB. Comprehensive and comparative metabolomic profiling of wheat, barley, oat and rye using gas chromatography-mass spectrometry and advanced chemometrics. *Foods* 2014;3:569–585.
- Cecchini NM, Roychoudhry S, Speed DJ, Steffes K, Tambe A et al. Underground Azelaic Acid-Conferred Resistance to *Pseudomonas syringae* in *Arabidopsis*. *Mol Plant Microbe Interact* 2019;32:86–94.
- Jung HW, Tschaplinski TJ, Wang L, Glazebrook J, Greenberg JT. Priming in systemic plant immunity. *Science* 2009;324:89–91.
- Javvadi SG, Cescutti P, Rizzo R, Lonzarich V, Navarin L et al. The spent culture supernatant of *Pseudomonas syringae* contains azelaic acid. *BMC Microbiol* 2018;18:199.
- Chapman PJ, Duggleby RG. Dicarboxylic acid catabolism by bacteria. *Biochem J* 1967;103:7contd-9c:7C–9.
- Harrison FH, Harwood CS. The *pimFABCDE* operon from *Rhodospirillum rubrum* mediates dicarboxylic acid degradation and participates in anaerobic benzoate degradation. *Microbiology* 2005;151:727–736.
- Parke D, Garcia MA, Ornston LN. Cloning and genetic characterization of *dca* genes required for beta-oxidation of straight-chain dicarboxylic acids in *Acinetobacter* sp. strain ADP1. *Appl Environ Microbiol* 2001;67:4817–4827.
- Janota-Bassalik L, Wright LD. Pimelic Acid as a by-Product of Azelaic Acid Degradation by *Pseudomonas* sp. *Nature* 1964;204:501–502.
- Janota-Bassalik L, Wright LD. Azelaic acid utilization by a *Pseudomonas*. *J Gen Microbiol* 1964;36:405–414.
- Lang E, Griese B, Spröer C, Schumann P, Steffen M et al. Characterization of '*Pseudomonas azelaica*' DSM 9128, leading to emended descriptions of *Pseudomonas citronellolis* Seubert 1960 (Approved Lists 1980) and *Pseudomonas nitroreducens* Iizuka and Komagata 1964 (Approved Lists 1980), including *Pseudomonas multiresinivorans* as its later heterotypic synonym. *Int J Syst Evol Microbiol* 2007;57:878–882.
- Hanahan D. Studies on transformation of *Escherichia coli* with plasmids. *J Mol Biol* 1983;166:557–580.
- Alexeyev MF. The pKNOCK series of broad-host-range mobilizable suicide vectors for gene knockout and targeted DNA insertion into the chromosome of gram-negative bacteria. *Biotechniques* 1999;26:828–.
- Sambrook J, Fritsch EF, Maniatis T. *Molecular Cloning: a Laboratory Manual*, 2nd ed. N.Y: Cold Spring Harbor; 1989.
- Miller JH. *Experiments in Molecular Genetics*. N.Y: Cold Spring Harbor; 1972.
- Better M, Lewis B, Corbin D, Ditta G, Helinski DR. Structural relationships among *Rhizobium meliloti* symbiotic promoters. *Cell* 1983;35:479–485.
- Figurski DH, Helinski DR. Replication of an origin-containing derivative of plasmid RK2 dependent on a plasmid function provided in *trans*. *Proc Natl Acad Sci U S A* 1979;76:1648–1652.
- Reeve WG, Tiwari RP, Worsley PS, Dilworth MJ, Glenn AR et al. Constructs for insertional mutagenesis, transcriptional signal localization and gene regulation studies in root nodule and other bacteria. *Microbiology* 1999;145:1307–1316.
- Simon R, Priefer U, Pühler A. A broad host range mobilization system for *in vivo* genetic engineering: transposon mutagenesis in Gram negative bacteria. *Biotechnology* 1983;1:784–791.
- O'Toole GA, Kolter R. Initiation of biofilm formation in *Pseudomonas fluorescens* WCS365 proceeds via multiple, convergent signalling pathways: a genetic analysis. *Mol Microbiol* 1998;28:449–461.
- Stachel SE, An G, Flores C, Nester EW. A *Tn3 lacZ* transposon for the random generation of beta-galactosidase gene fusions: application to the analysis of gene expression in *Agrobacterium*. *EMBO J* 1985;4:891–898.
- Bankevich A, Nurk S, Antipov D, Gurevich AA, Dvorkin M et al. SPAdes: a new genome assembly algorithm and its applications to single-cell sequencing. *J Comput Biol* 2012;19:455–477.
- Chen I-MA, Chu K, Palaniappan K, Pillay M, Ratner A et al. IMG/M v.5.0: an integrated data management and comparative analysis system for microbial genomes and microbiomes. *Nucleic Acids Res* 2019;47:D666–D677.
- Creevey CJ, Doerks T, Fitzpatrick DA, Raes J, Bork P. Universally distributed single-copy genes indicate a constant rate of horizontal transfer. *PLoS One* 2011;6:e22099.
- Capella-Gutiérrez S, Silla-Martínez JM, Gabaldón T. trimAl: a tool for automated alignment trimming in large-scale phylogenetic analyses. *Bioinformatics* 2009;25:1972–1973.
- Price MN, Dehal PS, Arkin AP. FastTree 2-approximately maximum-likelihood trees for large alignments. *PLoS One* 2010;5:e9490.
- Letunic I, Bork P. Interactive tree of life (iTOL) V3: an online tool for the display and annotation of phylogenetic and other trees. *Nucleic Acids Res* 2016;44:W242–W245.
- Chen H-J, Guo G-L, Tseng D-H, Cheng C-L, Huang S-L. Growth factors, kinetics and biodegradation mechanism associated with *Pseudomonas nitroreducens* TX1 grown on octylphenol polyethoxylates. *J Environ Manage* 2006;80:279–286.
- Molina-Henares AJ, Krell T, Eugenia Guazzaroni M, Segura A, Ramos JL. Members of the IclR family of bacterial transcriptional regulators function as activators and/or repressors. *FEMS Microbiol Rev* 2006;30:157–186.
- Fathepure BZ. Recent studies in microbial degradation of petroleum hydrocarbons in hypersaline environments. *Front Microbiol* 2014;5:173.
- Bikkina S, Kawamura K, Miyazaki Y, Fu P. High abundances of oxalic, azelaic, and glyoxylic acids and methylglyoxal in the open Ocean with high biological activity: implication for secondary oil formation from isoprene. *Geophys Res Lett* 2014;41:3649–3657.
- Weimar JD, DiRusso CC, Delio R, Black PN. Functional role of fatty acyl-coenzyme A synthetase in the transmembrane movement and activation of exogenous long-chain fatty acids. Amino acid residues within the ATP/AMP signature motif of *Escherichia coli* FadD are required for enzyme activity and fatty acid transport. *J Biol Chem* 2002;277:29369–29376.
- Klein K, Steinberg R, Fiethen B, Overath P. Fatty acid degradation in *Escherichia coli*. An inducible system for the uptake of fatty

- acids and further characterization of old mutants. *Eur J Biochem* 1971;19:442–450.
35. My L, Rekoske B, Lemke JJ, Viala JP, Gourse RL et al. Transcription of the *Escherichia coli* fatty acid synthesis operon *fabHDG* is directly activated by FadR and inhibited by ppGpp. *J Bacteriol* 2013;195:3784–3795.
 36. Dolan SK, Welch M. The glyoxylate shunt, 60 years on. *Annu Rev Microbiol* 2018;72:309–330.
 37. Staskawicz B, Dahlbeck D, Keen N, Napoli C. Molecular characterization of cloned avirulence genes from race 0 and race 1 of *Pseudomonas syringae* pv. *glycinea*. *J Bacteriol* 1987;169:5789–5794.
 38. Spaik HP, Okker RJ, Wijffelman CA, Pees E, Lugtenberg BJ. Promoters in the nodulation region of the *Rhizobium leguminosarum* Sym plasmid pRL1JI. *Plant Mol Biol* 1987;9:27–39.

Edited by: D. Grainger and D. Lee

Five reasons to publish your next article with a Microbiology Society journal

1. The Microbiology Society is a not-for-profit organization.
2. We offer fast and rigorous peer review – average time to first decision is 4–6 weeks.
3. Our journals have a global readership with subscriptions held in research institutions around the world.
4. 80% of our authors rate our submission process as 'excellent' or 'very good'.
5. Your article will be published on an interactive journal platform with advanced metrics.

Find out more and submit your article at microbiologyresearch.org.