

Life satisfaction prevents decline in working memory, spatial cognition, and processing speed: Latent change score analyses across 23 years

Research Article

Cite this article: Zainal NH, Newman MG (2022). Life satisfaction prevents decline in working memory, spatial cognition, and processing speed: Latent change score analyses across 23 years. *European Psychiatry*, 65(1), e27, 1–13
<https://doi.org/10.1192/j.eurpsy.2022.19>

Received: 12 December 2021
 Revised: 09 February 2022
 Accepted: 04 April 2022

Keywords:

Latent change; life satisfaction; processing speed; spatial cognition; working memory

Author for correspondence:

*Nur Hani Zainal,
 E-mail: hani.bzainal@gmail.com

Nur Hani Zainal^{1,2,3*}  and Michelle G. Newman² 

¹Massachusetts General Hospital, Harvard Medical School, Boston, Massachusetts, USA; ²Department of Psychology, The Pennsylvania State University, University Park, Pennsylvania, USA and ³National University of Singapore, Singapore

Abstract

Background. Within-person growth in life satisfaction (LS) can protect against declines in cognitive functioning, and, conversely, over time. However, most studies have been cross-sectional, thereby precluding causal inferences. Thus, we used *bivariate dual latent change score modeling* to test *within-person* change-to-future change relations between LS and cognition.

Method. Community adults completed in-person tests of verbal working memory (WM), processing speed, spatial cognition, and an LS self-report. Five waves of assessment occurred across 23 years.

Results. Reduction in LS predicted future decreases in spatial cognition, processing speed, and verbal WM ($|d| = 0.150\text{--}0.354$). Additionally, depletion in processing speed and verbal WM predicted a future decrease in LS ($d = 0.142\text{--}0.269$). However, change in spatial cognition did not predict change in LS ($|d| = 0.085$).

Discussion. LS and verbal WM and processing speed predicted one another across long durations. Evidence-based therapies can be augmented to target LS and cognition.

The challenges and opportunities of our daily lives require most of us to harness specific cognitive function abilities for successful navigation. These cognitive capacities include verbal working memory (WM; fluency to process mentally and change auditory data in real-time) [1], spatial cognition (ability to cognitively generate, sustain, retrieve, and alter visual objects) [2], and processing speed (capacity to fulfill rudimentary or intricate tasks that require persistent attention efficiently) [3]. These cognitive indices have been reliably correlated with various markers of biopsychosocial health. Diverse health indicators include mood regulation [4,5], physical health [6,7], school performance [8], work productivity [9], and quality of personal and professional relationships [10]. This is likely because spatial cognition, verbal WM, and processing speed are related to myriad basic attentional and complex higher-order executive functioning skills [11] and emotion modulation tactics [12]. Thus, enhancing our understanding of the predictors and outcomes of these aspects of cognitive function is essential.

It has been theorized that factors which facilitate the growth of psychological well-being, such as life satisfaction (LS), may prevent future long-term decline in cognitive abilities [13,14]. LS is the subjective global appraisal of the degree to which cumulative experiences thus far have been, on balance, fulfilling, and rewarding in the realms of health, relationships, career, and lived environments [15]. Relatedly, empirical evidence has shown that LS is a construct distinct from dispositional negative affect or worry (tendency to assume the worst) and depression (prolonged low mood) at a single time point and across long developmental periods [16,17].

Reduction in LS may lead to subsequent cognitive function deterioration across long durations via suboptimal lifestyle choices such as infrequent exercise and unhealthy diet and nutrition [18,19]. Failure to engage in health-promoting activities could lead to increased inflammation in executive functioning and related brain regions and weakened cardiovascular strength, thus causing long-term adverse effects of aging on cognitive function [20–23]. Such ideas are consistent with *scar theories* which argue that behavioral inactivity and repetitive negative thinking that may accompany a reduction in LS could over time negatively impact cognitive function abilities [24,25]. This process may occur through increased allostatic load (i.e., stress-linked wear and tear of the hypothalamic-pituitary-axis and cognitive function-related brain regions) [26] across long periods. Thus, a decrease in LS may dovetail with worsening of spatial cognition, verbal WM, and processing speed in the long term.

As yet, six longitudinal studies have tested the aforesaid idea that reduced LS and related concepts would be associated with subsequent cognitive function decline. For example, among older Swedish community adults, diminished LS coincided with a decrease in self-rated cognitive capacity from working life to post-retirement [27]; however, whether LS would forecast

performance-based cognitive function scores could not be deduced from that study. Other studies suggest such a possibility. Using latent growth curve modeling, Wilson et al. [28] and Salthouse [29] observed that *between persons*, lower scores on LS and related indices (e.g., satisfaction with relationships) predicted a more rapid decline in processing speed, global cognition, and memory over 6–13 years in early, middle, and late adulthood. Likewise, using hierarchical linear modeling, *within persons*, an 8-year decrease in psychological well-being was correlated with reductions in processing speed, memory, and global cognition among English midlife and older community adults during that period [30]; despite that, lead-lag relations were not examined in the study. A Switzerland-based study [31] that tested lead-lag associations showed that reduced LS predicted a 6-year decline in set-shifting (i.e., the adeptness to change from one mental mode to another [32]); however, due to its two-wave design, *change-to-future change* relations could not be inferred. Relatedly, within persons, a lower prior level of LS resulted in a greater 1.5–2-year decline in perceptual speed among older German adults across six waves of assessment [33].

Simultaneously, theorists have proposed that factors impeding goal attainment, such as a decline in cognitive function, may predict a reduction in LS across long durations [34,35]. This is because such executive functioning-related capacities are essential to engender and sustain progress and a sense of fulfillment in school, career, relationships, and other realms reflective of biopsychosocial health across time [36,37]. It is also plausible that increased cognitive function, such as processing speed, spatial cognition, and verbal WM, are protective against depletion of LS across development as these resources aid optimal problem definition, planning, and skillful decision-making [38,39]. Such cognitive resources-related strategic approaches include sacrificing short-term relief or pleasure to fulfill long-term aspirations [40]. Overall, it is tenable that a decline in verbal WM, processing speed and spatial cognition would predict a subsequent decrease in LS.

Thus far, seven studies have tested the proposition that a decline in LS would be related to future cognitive function deficits or vice versa. One earlier study evidenced no relation between LS and global cognition 6 years later in middle- to older-aged adults [41]. Conversely, middle-aged and older men who displayed stronger verbal WM and processing speed reported higher LS or positive affect following 7–12 years [42,43]. Similarly, another study that used ordinary least squares (OLS) regression demonstrated that higher baseline spatial cognition or processing speed scores predicted greater LS after 3 years in younger, middle-aged, and older adults [44]. Moreover, stronger WM ability predicted higher trait and daily levels of LS among college students [45]. In addition to performance-based cognitive function measures, two recent studies [27,46] showed that a decline in subjective cognitive capacity was associated with a later reduction in LS among adults transitioning to retirement.

Despite the progress made thus far to understand the relations between LS and cognitive function, literature still presents with several limitations the current study aimed to remedy. First, most studies testing LS–cognitive function relations were cross-sectional (e.g., [47–49]), thus precluding causal inferences due to the absence of temporal precedence. Second, most prior studies on this topic used OLS regression, latent growth modeling, and cross-lagged panel models, which permit conclusions on *between-person*, but not *within-person*, associations [50,51]. This is problematic as theories above on LS–cognitive function connections imply how *within-person* changes in each unique variable predict one another across the lifespan. Furthermore, relations between- and within-

persons can differ in magnitude and direction [5,52], underlining the need to tether *within-person* analytic methods to test preceding theories. Therefore, the present study used *bivariate dual latent change score* (BLCS) modeling. BLCS modeling is an advanced longitudinal structural equation modeling (SEM) technique that could examine *within-person* change-to-future change relations among unique variables [53,54]. BLCS reduces biases arising from between-person effects, measurement error, autoregressive self-feedback loops, baseline and prior scores, and regression to the mean [55]. BLCS thus allows a better understanding of how a change in cognitive function at a time lag is linked to a change in LS at a future time lag (and conversely) [16].

A better comprehension of the *within-person* factors that predict the decline in LS and cognitive function is imperative. Globally, societies are currently grappling with increasing economic, psychosocial, and public health burdens linked to diverse mental illnesses (e.g., depression and anxiety) and neurocognitive disorders (e.g., dementia) that compromise LS [56–58]. Studies that identify the risk factors for decline in cognitive function and LS may be helpful for developing effective prevention, early identification, and treatment strategies. Moreover, *within-person change* lies at the heart of clinical science [52,59]. Thus, based on the preceding theories and data, we used BLCS modeling to test lead-lag associations between LS and cognitive function across five time points spanning 23 years in a community adult sample. First, we hypothesized that within persons, a decline in LS at a prior time lag would be significantly related to decreased verbal WM, processing speed, and spatial cognition at the next adjacent time lag (Hypothesis 1). Likewise, we predicted that within-person decline in processing speed, verbal WM, and spatial cognition at a previous time lag would be substantially associated with a reduction in LS at the adjacent time lag (Hypothesis 2).

Method

Participants

The current study examined participants ($n = 560$) who gave permission to undergo face-to-face neuropsychology testing and to complete in-person self-report measures such as the LS questionnaire. Forty participants were removed from our analyses as they were diagnosed with dementia, leaving a final sample of 520 participants.¹ Of the 520 participants, 54.8% identified as probable or definite fraternal twins, 30.8% as identical twins, and the remaining 14.4% mentioned they did not know the nature of their twinship. In addition, 52% were reared together, and the remaining 48% were reared apart. The current sample were middle- to older-aged adults at baseline (M age = 59.61 years, $SD = 8.98$, range = 40.57–84.11; refer to Table S1 in the Supplementary Material [SM] for demographics at each time point). Females comprised 58% ($n = 302$) of the sample. Concerning formal education, 8.46% received elementary to lower secondary school, 21.20% had a high school education, and 70.40% attended college or higher academia, which included courses to acquire specialized skill sets (e.g., forestry and business).

¹Participants diagnosed with dementia using the Diagnostic and Statistical Manual of Mental Disorders-Third Edition [60, 61] were removed to understand the change-to-future change relations between life satisfaction and unique cognitive functioning domains in initially cognitively intact community adults. Nonetheless, a similar pattern of findings emerged when these participants were included.

Procedures

Using the Swedish Adoption/Twin Study of Aging publicly available dataset, the present study conducted a theoretically informed secondary analysis. The Karolinska Institutet provided ethical approval, and all participants gave voluntary informed consent. We were interested in the relations between LS and cognitive function (processing speed, verbal WM, and spatial cognition scores) instead of genetic heritability [62]. The study comprised five waves of assessment during these years: 1987 (Time 1; T1), 1990 (Time 2; T2), 1993 (Time 3; T3), 2004 (Time 4; T4), and 2007 (Time 5; T5). Due to funding deficits, a sizeable 11-year gap occurred between 1993 and 2004, and in-person cognitive testing was unavailable during this period. This led to five available time points with four sequential time lags ranging from 3 to 11 years. Thus, the present study examined if within-person change at a time lag (ΔT) in a variable was associated with change at the next sequential time lag ($\Delta T + 1$) in another variable. The following measures were administered at all five time points.

Measures

Life satisfaction

An 8-item self-report measure of LS adapted from [63]) was used. Respondents endorsed items on a 5-point Likert scale, ranging from 1 = *strongly disagree* to 5 = *strongly agree*. It showed satisfactory-to-good between-person reliability (Cronbach's $\alpha = .70-.79$) and within-person reliability ($\alpha = .70$) in the current study. Furthermore, the measure demonstrated good retest reliability ($r = .79$) [63], as well as strong convergent and discriminant validity [64,65]. Table S2 in the SM lists the items in this measure and details how the eight items in the current scale were derived from the original 13-item scale [64].

Spatial cognition

The Koh's block design (BD) and card rotations (CR) tests assessed spatial cognition. Koh's BD test parallels the Wechsler's Adult Intelligence Scale [66] BD subtest; participants were instructed to replicate seven increasingly difficult square- and triangle-filled figures with two-colored blocks. In addition, the CR test required participants to correctly select, upon mental rotation, one out of four items that matched a target figure on display. Scores for both tests indicated the total completion time (in seconds) for each presented figure. These assessments have shown strong between-person reliability ($\alpha = .81-.85$) and within-person reliability ($\alpha = .90$) herein, high 33-day test-retest reliability ($r = .90$) [67], and good discriminant and convergent validity [68].

Processing speed

The widely used oral version of the symbol digit modalities (SDM) test [69,70] measured processing speed capacity.² Participants orally indicated each integer (ranging from 1 to 9) linked to a specific unique symbol. The SDM test was administered in two blocks of 50 integers, each for 45 s. Possible scores ranged from 0 to 100. In the current study, the SDM test showed strong between-person ($\alpha = .90-.92$) and within-person reliability ($\alpha = .90$). Furthermore, it has shown strong 2-week retest reliability ($r = .74$), convergent and discriminant validity, with scores of measures of different constructs [71-73].

Verbal WM

The digit span (DS) test-backward was administered to assess verbal WM by instructing participants to register and recite three-to-nine number sequences of growing length in the reverse direction. The DS test-backward score was computed by summing the total number of digit sequences accurately recalled. Although DS test-forward measures verbal WM repetition, DS test-backward captures WM and attentional control processes reliably. It has excellent between-person ($\alpha = .93$) and within-person reliability ($\alpha = .89$), as well as retest reliability ($\alpha = .83$) [74]. Moreover, it has strong discriminant and convergent validity [75,76].

Data analyses

All preprocessing and data analyses were conducted with *R* version 4.1.0 [77] and *RStudio* Version 1.4.1717. First, using the *psych* *R* package [78], we inspected the data, determined that all variables were normally distributed, and observed no outliers (see Table S3 in the SM for descriptive statistics and correlation matrix of study variables). The *psych* *R* package [78] was also used to conduct psychometric analyses (e.g., compute reliabilities or internal consistency of scores on measures). Next, a series of SEM analyses were performed. To evaluate SEM model fit, these indices were used: Chi-square with degrees of freedom ($\chi^2(df)$) and related *p*-value; confirmatory fit index (CFI) [79]; and root-mean-square error of approximation (RMSEA) [80]. Moreover, nesting within twins was accounted for by utilizing the *lavaan.survey* *R* package [81]. Furthermore, maximum likelihood with robust sandwich estimators were used.

Figure S1 in the SM details the number of participants who completed the in-person cognitive function tests and the LS self-report at each time point. Missingness (a total of 24% of all observations) was managed by using multiple imputation with the raw item scores following recommended guidelines [82]. Data were aggregated across 100 multiply imputed datasets with the predictive mean matching algorithm, each with a maximum of 100 iterations; a gold standard approach in aging research [83]. Auxiliary variables that could have been related to dropout status (age, gender, education, baseline scores of cognitive functioning, and LS) were included in the multiple imputation models at all time points; a method that adjusts for any systematic trends in dropouts and yields parameter estimates aligned with the missing at random assumption. Moreover, multiple imputation (vs. complete case analysis) tends to produce unbiased, efficient, and precise parameter and standard error estimates that mirror those derived from complete datasets, even if total missingness exceeds 50% [84,85].³

As a precursor to longitudinal SEM, we tested for longitudinal measurement invariance of all the measures to determine if their psychometric properties were reproducible across all time points [86]. All levels of invariance were gradually tested in this order with increasingly restrictive models: *configural* (equal factor structure, varying factor loadings [λ s], item intercepts [τ s], and item residual variances [θ s]); *metric* (equal factor structure, λ s, varying τ s, and θ s); *scalar* (equal factor structure, λ s, and τ s, varying θ s); and *strict* (equal factor structure, λ s, τ s, and θ s). Measurement invariance was indicated by trivial changes in the practical fit indices; $\Delta CFI < -.010$ or $\Delta RMSEA < +.030$ when comparing the more (vs. less) constrained models [87,88].

²See [71] for updated norms of this test.

³Results of the analyses were similar with the unimputed dataset.

Next, we conducted a series of LCS models to test Hypotheses 1 and 2. Latent change scores were computed by fixing the regression path between scores at a prior time point and the next adjacent time point equal to 1 [50]. This indicated that a certain amount of the subsequent score was equivalent to the prior score, and the residual score was construed as the latent change score. Equations (1) and (2) below denote univariate dual LCS models for LS and cognitive function variables. ΔC and ΔL signify the latent change in each cognitive function variable and LS at a time lag (ΔT), respectively. The term α indicates the between-person constant change parameter of the slope of a variable, and β relays *within-person* proportional effects (autoregressive self-feedback loops of change in a variable forecasting future change in itself).

$$\Delta C_{[\Delta T]} = \alpha_C * C_S + \beta_c * C_{[\Delta T-1]}. \quad (1)$$

$$\Delta L_{[\Delta T]} = \alpha_L * L_S + \beta_c * L_{[\Delta T-1]}. \quad (2)$$

BLCS models were then conducted to test dynamic relations between LS and cognitive function within and between persons. By combining attributes of the cross-lagged panel and latent growth curve models, BLCS models examine change in each variable from one time point to an adjacent time point in a time-sequential manner across all time points [89]. It computes *within-person coupling effects*

(δ ; cross-lagged effects of change in a variable at a time lag predicting change in another variable at a successive time lag). Simultaneously, BLCS models minimize biases stemming from measurement unreliability, regression to the mean, baseline scores and between-persons (or trait-level) intercepts, variances, constant change, and other model parameters [90]. Equations (3) and (4) denote bivariate LCS models examined herein:

$$\Delta C_{[\Delta T]} = \alpha_C * C_S + \beta_c * C_{[\Delta T-1]} + \delta_L * L_{[\Delta T-1]}, \quad (3)$$

$$\Delta L_{[\Delta T]} = \alpha_L * L_S + \beta_c * L_{[\Delta T-1]} + \delta_C * C_{[\Delta T-1]}. \quad (4)$$

Furthermore, permitting within-person change-to-future change cross-construct coupling effects to be freely estimated across time-lags increases standard errors. Thus, following recommendations [91], we fixed the cross-construct coupling effects to be equal. Figure 1 displays the graphical representation of a BLCS model and embedded parameters. Furthermore, to account for differences in time-lag length herein (i.e., 3 vs. 11 year), we conducted a chi-square ($\Delta\chi^2(df)$) difference test [92] to examine if time-lag length significantly moderated critical parameter estimates (i.e., cross-construct coupling effects). Moreover, to determine if a change in LS predicting future change in cognitive functioning was stronger than vice versa, we conducted a $\Delta\chi^2(df)$ test of BLCS models with and without equality constraints on the within-

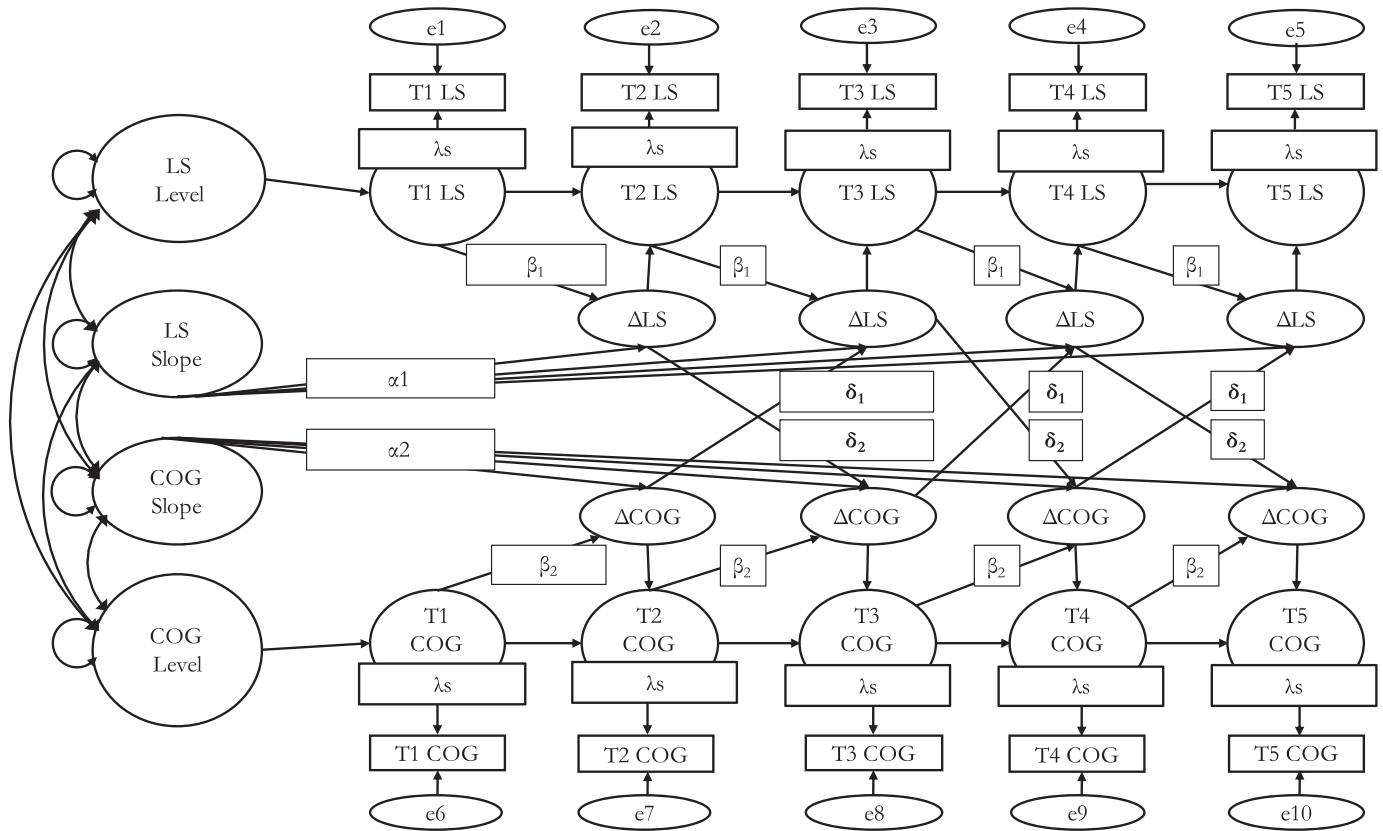

Figure 1. Bivariate dual latent change score model of LS and cognitive function.

Abbreviations: COG, global cognition; e, item-level residual error; LS, life satisfaction; T1, Time 1 (1987); T2, Time 2 (1990); T3, Time 3 (1993); T4, Time 4 (2004); T5, Time 5 (2007); α , between-person constant change; β , within-person proportional change (change in a variable predicting future change in itself); Δ , change in a variable; δ , within-person cross-domain coupling effect (change in a variable predicting future change in another variable); λ , factor loading.

person coupling effects. In addition, given multiple comparisons of parameter estimates within and across BLCS models, we used the mixture distribution approach of alpha correction recommended by Ke and Wang [93] and Wang and Yang [94], which reduces the odds of Type I error in BLCS models. Based on simulations using this approach, these authors recommend that for our current sample size ($N = 520$) and our five measurement points, a value of $p \leq 0.029$ would be the optimal cutoff to reduce the likelihood of Type I error [93,94]. Furthermore, Cohen's d effect sizes were computed with the formula $d = \beta / (SE(\beta)) \times \sqrt{(2/n)}$ [95], such that d values of 0.2, 0.5, and 0.8 indicated small, moderate, and large effects, respectively.

Power analysis

A Monte Carlo power analysis mirroring study conditions (a gold standard recommended approach) was conducted using the *RAM-path R* package [96]. To detect within-person change-to-future change cross-construct (coupling effects) and related parameter estimates (e.g., mean and variance) with conservative and small effect sizes ranging from $|d| = 0.10$ to 0.20, the current study had 97.4–100.0% power. Thus, the current study had an adequate sample size to conduct BLCS analyses.

Results

Longitudinal measurement invariance

As shown in Table 1, across all time points, the two-factor CFA model that included LS and each cognitive function variable displayed measurement invariance at the *strict* level (equal λ s, τ s, and ε s). This meant that measures herein had comparable psychometric properties and could be construed along with the same metric at all time points. Thus, longitudinal SEM was appropriate for this dataset.

Univariate latent change score models

Table 2 demonstrates that the model fit indices for the ULCS models were good for LS ($\chi^2(df = 13) = 50.479, p < 0.001, CFI = .963, RMSEA = .058$), spatial cognition ($\chi^2(df = 13) = 63.031, p < 0.001, CFI = .969, RMSEA = .086$), verbal WM ($\chi^2(df = 13) = 31.780, p < 0.001, CFI = .954, RMSEA = .053$), and processing speed ($\chi^2(df = 13) = 75.714, p < 0.001, CFI = .941, RMSEA = .097$). Within persons, higher level of cognitive functioning at a prior time point was significantly associated with greater rise in cognitive functioning at the next time lag for all specific cognitive functioning indices (spatial cognition: $\beta = 0.341, 95\% \text{ CI } [0.192, 0.491], p < 0.001, d = 0.278$; verbal WM: $\beta = 0.733, 95\% \text{ CI } [0.213, 1.253], p = 0.006, d = 0.172$; processing speed: $\beta = 0.234, 95\% \text{ CI } [0.114, 0.354], p < 0.001, d = 0.238$). However, level of LS at a previous time point was not significantly related to future change in itself within persons ($\beta = -0.043, 95\% \text{ CI } [-0.247, 0.161], p = 0.680, d = -0.036$).

Bivariate dual latent change score models

Life satisfaction and spatial cognition

Table 3 shows that the BLCS model examining within-person change-to-future change associations between LS and spatial cognition had good model fit ($\chi^2(df = 40) = 118.780, p < 0.001, CFI = .968, RMSEA = .063$). Within persons, prior greater decrease in LS at a 3–10-year time lag was significantly linked to higher future reduction in spatial cognition ability at the following time lag ($\beta = -12.661, 95\% \text{ CI } [-22.892, -2.430], p = 0.015, d = -0.150$). However, change in spatial cognition at a time lag was not significantly related to change in LS at the next adjacent time lag ($\beta = -0.030, 95\% \text{ CI } [-0.072, 0.013], p = 0.177, d = -0.085$). In addition, the cross-lagged change-to-future change association was significantly stronger for LS predicting spatial cognition ability than the reverse direction ($\Delta\chi^2(df = 1) = 4.167, p = 0.041$). Furthermore, time-lag length did not significantly moderate cross-construct

Table 1. Longitudinal measurement invariance of the four-factor model of LS and cognition.

	WLSMV χ^2	df	p	CFI	RMSEA
Four-factor model of LS and cognition (spatial WM, verbal WM, and processing speed)					
Time 1 (1986–1988)	97.564	50	<0.001	.971	.050
Time 2 (1989–1991)	104.132	50	<0.001	.967	.051
Time 3 (1992–1994)	109.914	50	<0.001	.961	.053
Time 5 (2005–2007)	84.893	50	<0.001	.963	.052
Time 6 (2007–2008)	84.443	50	<0.001	.955	.061
Level of measurement invariance					
Configural (varying λ , τ , ε across time)	489.792	254	<0.001	.964	.053
Metric (equal λ , varying τ , ε across time)	610.792	282	<0.001	.950	.059
Scalar (equal λ , τ , varying ε across time)	706.402	314	<0.001	.940	.061
Strict (equal λ , τ , ε across time)	793.346	354	<0.001	.933	.061
Tests of measurement invariance					
Configural invariance vs. metric invariance	$\Delta\chi^2(df = 28) = 121.000, p < 0.001, \Delta CFI = -.014, \Delta RMSEA = .007$				
Metric invariance vs. scalar invariance	$\Delta\chi^2(df = 32) = 95.610, p < 0.001, \Delta CFI = -.001, \Delta RMSEA = .002$				
Scalar invariance vs. strict invariance	$\Delta\chi^2(df = 40) = 86.944, p < 0.001, \Delta CFI = -.007, \Delta RMSEA = -.000$				

Abbreviations: CFI, confirmatory fit index; LS, life satisfaction; RMSEA, root-mean-square error of approximation; WM, working memory; ε s, residual variances; λ s, factor loadings; τ s, intercepts.

Table 2. Univariate latent change score models of each variable.

Within-person proportional change (β)	LS			Spatial cognition		
	β	[95% CI]	ES <i>d</i>	β	[95% CI]	ES <i>d</i>
	-0.043	[-0.247, 0.161]	-0.036	0.341***	[0.192, 0.491]	0.278
Initial status						
Mean	2.556***	[2.494, 2.618]	8.364	36.683***	[35.619, 37.748]	4.190
Variance	0.420***	[0.348, 0.493]	0.624	127.403***	[111.697, 143.108]	0.986
Constant change (α)						
Mean	0.156	[-0.371, 0.683]	0.038	-13.924***	[-19.089, -8.759]	-0.328
Variance	0.019***	[0.010, 0.139]	0.155	14.539***	[1.931, 27.147]	0.140
Correlation between initial status and α	-0.044	[-0.112, 0.024]	-0.007	-41.966***	[-62.096, -21.835]	-0.253
Residual error						
σ_e^2	0.147***	[0.130, 0.165]	0.992	29.435***	[26.605, 32.265]	1.264
Model fit						
χ^2	50.479			63.031		
<i>df</i>	13			13		
<i>p</i>	<.001			<.001		
CFI	.963			.969		
RMSEA	.058			.086		
Within-person proportional change (β)	Verbal WM			Processing Speed		
	β	[95% CI]	ES <i>d</i>	β	[95% CI]	ES <i>d</i>
	0.733**	[0.213, 1.253]	0.172	0.234***	[0.114, 0.354]	0.238
Initial status						
Mean	4.259***	[4.148, 4.371]	4.634	58.238***	[57.281, 59.194]	5.307
Variance	0.951***	[0.753, 1.148]	0.584	108.215***	[92.549, 123.881]	0.840
Constant change (α)						
Mean	-3.189***	[-5.334, -1.044]	-0.181	-11.397***	[-18.726, -4.068]	-0.313
Variance	0.532	[-0.197, 1.261]	0.959	6.082*	[0.205, 11.959]	0.126
Correlation between initial status and α	-0.709**	[-1.211, -0.207]	-0.172	-23.198***	[-37.594, -8.802]	-0.196
Residual error						
σ_e^2	0.943***	[0.822, 1.063]	0.089	27.200***	[23.114, 31.286]	0.809
Model fit						
χ^2	31.780			75.714		
<i>df</i>	13			13		
<i>p</i>	<.001			<.001		
CFI	.954			.941		
RMSEA	.053			.097		

Abbreviations: CFI, confirmatory fit index; *df*, degrees of freedom; LS, life satisfaction; RMSEA, root-mean-square error of approximation; VSP, visual-spatial processing.

* $p < 0.05$.

** $p < 0.01$.

*** $p < 0.001$.

coupling effects ($\Delta\chi^2(df = 1) = 2.323, p = 0.127$). Moreover, time-lag length differences (3 vs. 11 year) did not significantly moderate the change-to-future change cross-construct coupling effects between spatial cognition and LS ($\Delta\chi^2(df = 2) = 2.009, p = 0.366$).

Life satisfaction and verbal WM

Table 4 demonstrates that the BLCS model testing within-person change-to-future relations between LS and verbal WM had good model fit ($\chi^2(df = 40) = 87.780, p < 0.001, CFI = .962$,

Table 3. Bivariate latent difference score models of spatial cognition and LS.

Parameter estimate	Spatial cognition and LS					
	$\Delta\text{Spatial Cognition}_{T-1} \rightarrow \Delta\text{LS}_T$			$\Delta\text{LS}_{T-1} \rightarrow \Delta\text{Spatial Cognition}_T$		
	β	[95% CI]	d	β	[95% CI]	d
Within-person bivariate change-to-change coupling effects (δ)	-0.030	[-0.072, 0.013]	-0.085	-12.661*	[-22.892, -2.430]	-0.150
Within-person proportional change (β)	$\Delta\text{Spatial Cognition}_{T-1} \rightarrow \Delta\text{Spatial Cognition}_T$			$\text{LS}_{T-1} \rightarrow \Delta\text{LS}_T$		
	0.171	[-0.129, 0.470]	0.069	-0.241	[-0.486, 0.005]	-0.120
	Spatial Cognition			LS		
Initial status						
Mean	36.655***	[35.571, 37.739]	4.111	2.556***	[2.491, 2.621]	4.804
Variance	131.221***	[113.427, 149.015]	0.896	0.433***	[0.359, 0.507]	0.707
Constant change (α)						
Mean	-7.583	[-18.211, 3.045]	-0.087	0.645*	[0.045, 1.245]	0.131
Variance	6.754	[-2.924, 16.431]	0.085	0.023	[-0.000, 0.047]	0.119
Residual error						
σ_e^2	28.987***	[25.965, 32.008]	1.166	0.148***	[0.130, 0.165]	1.020
Model fit						
χ^2	118.780					
df	40					
p	<.001					
CFI	.968					
RMSEA	.063					

Abbreviations: CFI, confirmatory fit index; CI, confidence interval; df , degrees of freedom; LS, life satisfaction; RMSEA, root-mean-square error of approximation; Δ , change in a parameter estimate at one time lag.

* $p < 0.05$.

*** $p < 0.001$.

RMSEA = .052). Within-person decrease in LS at a 3–10-year time lag was significantly related to decrement in verbal WM during the adjacent subsequent time lag ($\beta = 1.637$, 95% CI [0.680, 2.594], $p = 0.001$, $d = 0.208$). Likewise, within-person decline in verbal WM at a 3–10-year time lag was significantly associated with reduction in LS at the next successive time lag ($\beta = 0.357$, 95% CI [0.051, 0.664], $p = 0.022$, $d = 0.142$). In addition, the change-to-future change relation for LS predicting verbal WM was significantly stronger than the reverse ($\Delta\chi^2(df = 1) = 4.153$, $p = 0.042$). Furthermore, time-lag length differences (3 vs. 11 year) did not significantly moderate the change-to-future change cross-construct coupling effects between verbal WM and LS ($\Delta\chi^2(df = 2) = 2.195$, $p = 0.334$).

Life satisfaction and processing speed

Table 5 conveys that the BLCS model determining within-person change-to-future change associations between LS and processing speed had good model fit ($\chi^2(df = 40) = 147.622$, $p < 0.001$, CFI = .948, RMSEA = .072). Within persons, decline in LS at a prior 3–10-year time lag was significantly related to reduction in processing speed at the next time lag ($\beta = 11.437$, 95% CI [6.261, 16.613], $p < 0.001$, $d = 0.354$), and vice versa ($\beta = 0.040$, 95% CI [0.026, 0.054], $p < 0.001$, $d = 0.269$). Furthermore, the magnitude of change-to-future change relations was significantly stronger for LS predicting processing speed than conversely ($\Delta\chi^2(df = 1) = 4.359$, $p = 0.037$). In addition, time-lag length differences (3 vs. 11 year)

did not significantly moderate the change-to-future change cross-construct coupling effects between processing speed and LS ($\Delta\chi^2(df = 2) = 1.409$, $p = 0.494$).

Discussion

Consistent with the foregoing theories, findings showed that across five time points over 23 years, larger reduction in LS at a time lag was notably related to greater decline in spatial cognition, verbal WM, and processing speed at a future successive time lag. Simultaneously, partially supporting Hypotheses 1 and 2, a larger decrease in LS at a time lag was preceded and associated with greater diminished verbal WM and processing speed, but not spatial cognition. Small yet significant within-person, cross-lagged, change-to-future change relations emerged across time ($|d| = 0.142\text{--}0.354$). These *within-person* change-to-future change relations held over and above self-feedback loops, regression to the mean, between-person effects, and prior scores. We offer some theoretical accounts for this pattern of findings to contribute to the literature on aging, cognitive functioning, and subjective well-being.

Why did a reduction in LS at a time lag consistently forecast a worsening of verbal WM, spatial cognition, and processing speed at the next time lag? This finding may be accounted for by scar theories, which propose and show that reduced LS and related mental health issues (e.g., excessive worry) can, over time, lead to decreases in cognitive functioning via heightened allostatic load

Table 4. Bivariate latent difference score models of verbal WM and LS.

Parameter estimate	Verbal WM and LS					
	$\Delta\text{VWM}_{t-1} \rightarrow \Delta\text{LS}_t$			$\Delta\text{LS}_{t-1} \rightarrow \Delta\text{VWM}_t$		
	β	[95% CI]	d	β	[95% CI]	d
Within-person bivariate change-to-change coupling effects (δ)	0.357***	[0.051, 0.664]	0.142	1.637**	[0.680, 2.594]	0.208
Within-person proportional change (β)	$\text{VWM}_{t-1} \rightarrow \Delta\text{VWM}_t$			$\text{LS}_{t-1} \rightarrow \Delta\text{LS}_t$		
	0.478	[-0.026, 0.982]	0.115	-0.226	[-0.424, -0.027]	-0.139
	Verbal WM			LS		
Initial status						
Mean	4.749***	[4.631, 4.866]	4.909	2.561***	[2.496, 2.625]	4.813
Variance	1.007***	[0.784, 1.229]	0.553	0.433***	[0.360, 0.507]	0.707
Constant change (α)						
Mean	0.340	[-0.203, 0.884]	-0.110	0.612*	[0.104, 1.120]	0.147
Variance	0.077	[-0.006, 0.159]	0.076	0.027**	[0.008, 0.047]	0.167
Residual error						
σ_e^2	0.942***	[0.822, 1.063]	0.958	0.146***	[0.128, 0.164]	1.006
Model fit						
χ^2	87.780					
df	40					
p	<.001					
CFI	.962					
RMSEA	.052					

Abbreviations: CFI, confirmatory fit index; CI, confidence interval; df , degrees of freedom; LS, life satisfaction; RMSEA, root-mean-square error of approximation; VWM, verbal working memory; Δ , change in a parameter estimate at one time lag.

* $p < 0.05$.

** $p < 0.01$.

*** $p < 0.001$.

[21,97]. This cascade of events may occur in the long term (e.g., 9–23 years) [24,25], plausibly via higher levels of markers of inflammatory activity (e.g., peripheral cytokines) and chronic stress (e.g., cortisol) in the bloodstream [23,98]. The continuing effect of decreased LS on allostatic load may alter cardiorespiratory and neurophysiological pathways in the amygdala and left precuneus, ventromedial prefrontal cortex, and striatum brain regions over long durations [99,100]. Importantly, these areas have been identified as essential for executive functioning, optimal reward processing, and emotion modulation [101]. Future longitudinal basic science studies can evaluate the strength of evidence for these propositions.

Simultaneously, what factors may account for decreases in processing speed and verbal WM preceding and predicting a decline in LS? Findings are concordant with theorists who propose the importance of processing speed [102,103] and WM [104] resources to fulfill goals and tasks to create a sense of gratification across development (*satisfaction-of-goals theory*) [49]. It is tenable that throughout life, these cognitive functioning domains promote higher levels of perceived control goal planning, execution, attainment, and related factors. Supporting these assertions, prior BLCS research showed that a decline in processing speed or WM coincided with the ability to perform activities of daily living [105], as well as a rise in trait negative affect and depression severity [7]. Subsequent cross-panel LCS mediation investigations with four or more assessment waves can test our proposed ideas.

Unexpectedly, change in spatial cognition was not related to future change in LS. This null finding might be due to the fact that the ability to mentally process and alter visual objects in real time as indexed by the DB and CR spatial cognition measures might not be as essential as WM and processing speed in everyday life. This conjecture awaits further empirical testing. In addition, the nonsignificant within-person change-to-future change in spatial cognition–LS connections herein were inconsistent with a prior OLS regression-based study of older adults [44], showing that between persons, higher spatial cognition predicted greater future LS. Differences in analytic data techniques (e.g., findings at the within-person level may not translate to the between-person level) [106], measures used, and sample attributes may contribute to any observed discrepancies in the literature. In addition, the effect of reduction in LS on future decline in spatial cognition, verbal WM, and processing speed was more substantial than in the opposite direction. Such findings might be attributed to how measures of cognitive functioning used herein might not necessarily reflect tasks of everyday living (e.g., house chores, grocery shopping, and balancing a checkbook) in community adults and, therefore, might not be as noticeable or bothersome [107]. These results could also be explained by how LS markedly affects daily motivation, mood, work and social functioning, and health behaviors [108,109], factors that likely impacted various cognitive domains. Future empirical research work can test these possibilities.

Table 5. Bivariate latent difference score models of processing speed and LS.

Parameter estimate	Processing speed and LS					
	$\Delta\text{Processing Speed}_{t-1} \rightarrow \Delta\text{LS}_t$			$\Delta\text{LS}_{t-1} \rightarrow \Delta\text{Processing Speed}_t$		
Within-person bivariate change-to-change coupling effects (δ)	β	[95% CI]	d	β	[95% CI]	d
	0.040***	[0.026, 0.054]	0.354	11.437***	[6.261, 16.613]	0.269
Within-person proportional change (β)	Processing Speed $_{t-1} \rightarrow \Delta\text{Processing Speed}_t$			LS $_{t-1} \rightarrow \Delta\text{LS}_t$		
	0.105	[-0.046, 0.256]	0.085	-0.259**	[-0.431, -0.088]	-0.183
	Processing Speed			LS		
Initial status						
Mean	-41.698***	[-42.677, -40.720]	-5.182	2.597***	[2.531, 2.662]	4.881
Variance	112.772***	[96.305, 129.238]	0.833	0.417***	[0.344, 0.489]	0.699
Constant change (α)						
Mean	6.782*	[0.918, 12.646]	0.141	0.649**	[0.204, 1.094]	0.177
Variance	5.657**	[1.837, 9.476]	0.180	0.029**	[0.011, 0.047]	0.200
Residual error						
σ_e^2	26.622***	[22.648, 30.597]	0.814	0.149***	[0.131, 0.168]	1.027
Model fit						
χ^2	147.622					
df	40					
p	<.001					
CFI	.948					
RMSEA	.072					

Abbreviations: CFI, confirmatory fit index; CI, confidence interval; df , degrees of freedom; LS, life satisfaction; RMSEA, root-mean-square error of approximation; Δ , change in a parameter estimate at one time lag.

* $p < 0.05$.

** $p < 0.001$.

The current study has some limitations. One limitation was the use of two spatial cognition tests, one processing speed test, and one WM test. Future research could clarify if other important cognitive function domains (e.g., verbal fluency) [7,110]) would be related to LS with comprehensive multiple-item cognitive tests. Subsequent studies should also include subjective cognitive function measures since they may differ from performance-based ones and function as early warning signs of incident dementia [111]. Furthermore, our study included one time lag that was significantly longer than the others, which may have influenced our findings. However, we determined that the pattern of results did not differ substantially based on the time-lag length, and we used the least biased method of analyzing data with different lag lengths [91]. Another possibility is that systematic attrition impacted our findings. Nonetheless, we used a gold standard data replacement strategy that accounts for systematic associations between study variables and missingness. In addition, the oral SDM test used herein tends to yield higher scores than written graphomotor forms [71]. However, given that the current study focused entirely on change in the same test over time, higher scores would likely be present at all time points and would not have affected our current findings. Future studies should use processing speed tests that comprise both oral and written components to obtain more reliable estimates of individuals' processing speed abilities. In addition, the tests used herein had poor ecological validity because these tasks (e.g., BD) are rarely if at all, required in day-to-day living in the real world, thus highlighting the importance of using ecologically valid cognitive functioning measures

(e.g., [112]) in future studies. Relatedly, unmeasured third variables (e.g., motivation, self-efficacy, perceived social connectedness, and positive affect) [113,114] should be considered. Finally, cognitive functioning tests, in particular, can be associated with practice effects, particularly across relatively shorter retest intervals of less than 2 years [115–117]. However, we do not believe that practice effects explain our significant results for several reasons. First, our time lag length was 3–11 years, and at least one study found no cognitive improvement across three years [116]. Second, our analyses examined the bidirectional relationship between waning LS and *worsening cognitive functioning*. If there were any impact of practice effects on cognitive functioning, this would mask (rather than enhance) cognitive functioning decline and likely diminish the bidirectional within-person association between reduced LS and worsening cognitive function. These shortcomings aside, study strengths include the well-powered sample size, study novelty, and use of multiple assessments to capture cognitive function that minimized measurement error. Furthermore, the current study utilized a suitable advanced SEM method that permits inferences of within-person change-to-future change relations to evaluate the preceding theories and advance literature empirically.

If the pattern of results herein is reproduced, the current study has some clinical implications. First, meditation- and mindfulness-based interventions have increasingly shown promise to enhance sustained attention, WM, spatial attention, and related cognitive function markers [118–120], or protect against their worsening decline across long durations in highly stressful situations

[121,122]. In addition, lifestyle-based (e.g., cognitive-behavioral therapies, dancing, and yoga) [123,124] and cognitive function interventions (e.g., executive functioning or memory training, and reminiscence therapy) [125–128] have been shown to boost cognitive function or LS in adults. However, the state of research on this topic is nascent. Thus, conducting more gold standard randomized controlled trials can aid in drawing more definitive conclusions on their efficacy to enhance LS and cognitive function at the prevention and treatment stages across adulthood. In addition, based on emerging evidence [129], clinical science can profit from future studies by testing if cognitive function serves as a treatment predictor, moderator, or mediator, to better understand mechanisms of change and optimize treatments.

Supplementary Materials. To view supplementary material for this article, please visit <http://doi.org/10.1192/j.eurpsy.2022.19>.

Data Availability Statement. The Swedish Adoption/Twin Study on Aging (SATSA) publicly available dataset used herein was obtained via the Inter-University Consortium of Political and Social Research (ICPSR) data repository website (<https://www.icpsr.umich.edu/icpsrweb/NACDA/studies/3843>).

Author Contributions. Conceptualization: N.H.Z.; Data curation: N.H.Z. and M.G.N.; Formal analysis: N.H.Z.; Methodology: N.H.Z.; Writing—original draft: N.H.Z.; Writing—review & editing: N.H.Z. and M.G.N.

Funding Statement. The Swedish Adoption/Twin Study on Aging study was supported by the following funding agencies and grants: John D. and Catherine T. MacArthur Foundation, Research Network on Successful Aging, United States Department of Health and Human Services, National Institutes of Health, National Institute on Aging (AG04563, AG10175, and AG08724), Swedish Research Council (825-2007-7460, 825-2009-6141, and 825-3011-6182), and Swedish Council for Working Life and Social Research (97:0147:1B and 2009-0795).

Ethical Standards. This study was performed in accordance with the Declaration of Helsinki.

Conflicts of Interest. Both authors do not have conflicts of interest to disclose.

Acknowledgements. The original investigators and funding agency are not responsible for the analyses or interpretations presented here. We would like to thank Professor Peter C. M. Molenaar for offering statistical consultation during the process of conducting data analyses.

References

- [1] Cowan N, Roudner JN, Blume CL, Sauls JS. Models of verbal working memory capacity: what does it take to make them work? *Psychol Rev.* 2012;119:480–99. doi:10.1037/a0027791.
- [2] Klencklen G, Despres O, Dufour A. What do we know about aging and spatial cognition? Reviews and perspectives. *Ageing Res Rev.* 2012;11:123–35. doi:10.1016/j.arr.2011.10.001.
- [3] Eckert MA. Slowing down: age-related neurobiological predictors of processing speed. *Front Neurosci.* 2011;5:25. doi:10.3389/fnins.2011.00025.
- [4] Nigg JT. On the relations among self-regulation, self-control, executive functioning, effortful control, cognitive control, impulsivity, risk-taking, and inhibition for developmental psychopathology. *J Child Psychol Psychiatry.* 2017;58:361–83. doi:10.1111/jcpp.12675.
- [5] Zainal NH, Newman MG. Executive function and other cognitive deficits are distal risk factors of generalized anxiety disorder 9 years later. *Psychol Med.* 2018;48:2045–53. doi:10.1017/S0033291717003579.
- [6] Quinones MM, Gallegos AM, Lin FV, Heffner K. Dysregulation of inflammation, neurobiology, and cognitive function in PTSD: an integrative review. *Cogn Affect Behav Neurosci.* 2020;20:455–80. doi:10.3758/s13415-020-00782-9.
- [7] Zainal NH, Newman MG. Depression and executive functioning bidirectionally impair one another across 9 years: evidence from within-person latent change and cross-lagged models. *Eur Psychiatry.* 2021;64:e43. doi:10.1192/j.eurpsy.2021.2217.
- [8] Cook NE, Braaten EB, Surman CBH. Clinical and functional correlates of processing speed in pediatric attention-deficit/hyperactivity disorder: a systematic review and meta-analysis. *Child Neuropsychol.* 2018;24:598–616. doi:10.1080/09297049.2017.1307952.
- [9] van Dijk DM, van Rhenen W, Murre JMJ, Verwijk E. Cognitive functioning, sleep quality, and work performance in non-clinical burnout: the role of working memory. *PLoS One.* 2020;15:e0231906. doi:10.1371/journal.pone.0231906.
- [10] Knight MJ, Baune BT. Executive function and spatial cognition mediate psychosocial dysfunction in major depressive disorder. *Front Psych.* 2018;9:539. doi:10.3389/fpsy.2018.00539.
- [11] Salthouse TA. Shared and unique influences on age-related cognitive change. *Neuropsychology.* 2017;31:11–9. doi:10.1037/neu0000330.
- [12] Groves NB, Kofler MJ, Wells EL, Day TN, Chan ESM. An examination of relations among working memory, ADHD symptoms, and emotion regulation. *J Abnorm Child Psychol.* 2020;48:525–37. doi:10.1007/s10802-019-00612-8.
- [13] Fiocco AJ, Yaffe K. Defining successful aging: the importance of including cognitive function over time. *Arch Neurol.* 2010;67:876–80. doi:10.1001/archneurol.2010.130.
- [14] Ratigan A, Kritiz-Silverstein D, Barrett-Connor E. Sex differences in the association of physical function and cognitive function with life satisfaction in older age: the rancho Bernardo study. *Maturitas.* 2016;89:29–35. doi:10.1016/j.maturitas.2016.04.007.
- [15] Veenhoven R. The overall satisfaction with life: subjective approaches (1). In: Glatzer W, Camfield L, Møller V, Rojas M, editors. *Global handbook of quality of life: exploration of well-being of nations and continents.* Dordrecht: Springer; 2015, p. 207–38. doi:10.1007/978-94-017-9178-6_9.
- [16] Hounkpatin HO, Boyce CJ, Dunn G, Wood AM. Modeling bivariate change in individual differences: prospective associations between personality and life satisfaction. *J Pers Soc Psychol.* 2018;115:e12–29. doi:10.1037/pspp0000161.
- [17] Johnson MD, Neyer FJ, Finn C. Subjective well-being across partnerships. *J Fam Psychol.* 2021;35:546–51. doi:10.1037/fam0000793.
- [18] Grant N, Wardle J, Steptoe A. The relationship between life satisfaction and health behavior: a cross-cultural analysis of young adults. *Int J Behav Med.* 2009;16:259–68. doi:10.1007/s12529-009-9032-x.
- [19] Kim ES, Park N, Sun JK, Smith J, Peterson C. Life satisfaction and frequency of doctor visits. *Psychosom Med.* 2014;76:86–93. doi:10.1097/PSY.000000000000024.
- [20] Baumann M, Tchicaya A, Lorentz N, Le Bihan E. Life satisfaction and longitudinal changes in physical activity, diabetes and obesity among patients with cardiovascular diseases. *BMC Public Health.* 2017;17:925. doi:10.1186/s12889-017-4925-0.
- [21] Fancourt D, Steptoe A. The longitudinal relationship between changes in wellbeing and inflammatory markers: are associations independent of depression? *Brain Behav Immun.* 2020;83:146–52. doi:10.1016/j.bbi.2019.10.004.
- [22] Woo J, Lehrer HM, Whyne E, Steinhardt M. The longitudinal association of psychological resources with chronic conditions and the mediating roles of health behaviours and allostatic load. *Psychol Health.* 2020;35:629–43. doi:10.1080/08870446.2019.1656205.
- [23] Zainal NH, Newman MG. Inflammation mediates depression and generalized anxiety symptoms predicting executive function impairment after 18 years. *J Affect Disord.* 2022;465–75. doi:10.1016/j.jad.2021.08.077.
- [24] Zainal NH, Newman MG. Within-person increase in pathological worry predicts future depletion of unique executive functioning domains. *Psychol Med.* 2021;1676–1686. doi:10.1017/S0033291720000422.
- [25] Zainal NH, Newman MG. Larger increase in trait negative affect is associated with greater future cognitive decline and vice versa across 23 years. *Depress Anxiety.* 2021;38:146–60. doi:10.1002/da.23093.
- [26] D’Amico D, Amestoy ME, Fiocco AJ. The association between allostatic load and cognitive function: a systematic and meta-analytic review.

- Psychoneuroendocrinology. 2020;121:104849. doi:10.1016/j.psyneuen.2020.104849.
- [27] Hansson I, Buratti S, Thorvaldsson V, Johansson B, Berg AI. Disentangling the mechanisms of retirement adjustment: determinants and consequences of subjective well-being. *Work Aging Retire.* 2020;6:71–87. doi:10.1093/workar/waz021.
- [28] Wilson RS, Boyle PA, Segawa E, Yu L, Begeny CT, Anagnos SE, et al. The influence of cognitive decline on well-being in old age. *Psychol Aging.* 2013;28:304–13. doi:10.1037/a0031196.
- [29] Salthouse TA. Correlates of cognitive change. *J Exp Psychol Gen.* 2014;143:1026–48. doi:10.1037/a0034847.
- [30] Allerhand M, Gale CR, Deary IJ. The dynamic relationship between cognitive function and positive well-being in older people: a prospective study using the English longitudinal study of aging. *Psychol Aging.* 2014;29:306–18. doi:10.1037/a0036551.
- [31] Ihle A, Ghisletta P, Gouveia ER, Gouveia BR, Oris M, Maurer J, et al. Lower executive functioning predicts steeper subsequent decline in well-being only in young-old but not old-old age. *Int J Behav Dev.* 2020;45:97–108. doi:10.1177/0165025420937076.
- [32] Miyake A, Friedman NP. The nature and organization of individual differences in executive functions. *Curr Dir Psychol Sci.* 2012;21:8–14. doi:10.1177/0963721411429458.
- [33] Gerstorf D, Lövdén M, Röcke C, Smith J, Lindenberger U. Well-being affects changes in perceptual speed in advanced old age: longitudinal evidence for a dynamic link. *Dev Psychol.* 2007;43:705–18. doi:10.1037/0012-1649.43.3.705.
- [34] Baumeister RF, Schmeichel BJ, Vohs KD. Self-regulation and the executive function: the self as controlling agent. In: *Social psychology: handbook of basic principles.* 2nd ed. New York: The Guilford Press; 2007, p. 516–39.
- [35] Diener E, Suh EM, Lucas RE, Smith HL. Subjective well-being: three decades of progress. *Psychol Bull.* 1999;125:276–302. doi:10.1037/0033-2909.125.2.276.
- [36] Diamond A. Executive functions. *Annu Rev Psychol.* 2013;64:135–68. doi:10.1146/annurev-psych-113011-143750.
- [37] Diener E, Oishi S, Tay L. Advances in subjective well-being research. *Nat Hum Behav.* 2018;2:253–60. doi:10.1038/s41562-018-0307-6.
- [38] Biederman J, Petty CR, Fried R, Doyle AE, Spencer T, Seidman LJ, et al. Stability of executive function deficits into young adult years: a prospective longitudinal follow-up study of grown up males with ADHD. *Acta Psychiatr Scand.* 2007;116:129–36. doi:10.1111/j.1600-0447.2007.01008.x.
- [39] Swanson HL, Fung W. Working memory components and problem-solving accuracy: are there multiple pathways? *J Educ Psychol.* 2016;108:1153–77. doi:10.1037/edu0000116.
- [40] Hofmann W, Schmeichel BJ, Baddeley AD. Executive functions and self-regulation. *Trends Cogn Sci.* 2012;16:174–80. doi:10.1016/j.tics.2012.01.006.
- [41] Comijs HC, Dik MG, Aartsen MJ, Deeg DJ, Jonker C. The impact of change in cognitive functioning and cognitive decline on disability, well-being, and the use of healthcare services in older persons. Results of Longitudinal Aging Study Amsterdam. *Dement Geriatr Cogn Disord.* 2005;19:316–23. doi:10.1159/000084557.
- [42] Rouch I, Achour-Crawford E, Roche F, Castro-Lionard C, Laurent B, Ntougou Assoumou G, et al. Seven-year predictors of self-rated health and life satisfaction in the elderly: the proof study. *J Nutr Health Aging.* 2014;18:840–7. doi:10.1007/s12603-014-0557-6.
- [43] Siedlecki KL, Yazdani N, Minahan J, Falzarano F. Examining processing speed as a predictor of subjective well-being across age and time in the German aging survey. *Aging Neuropsychol Cognit.* 2020;27:66–82. doi:10.1080/13825585.2019.1585514.
- [44] Enkvist A, Ekström H, Elmståhl S. Associations between cognitive abilities and life satisfaction in the oldest-old. Results from the longitudinal population study good aging in Skåne. *Clin Interv Aging.* 2013;8:845–53. doi:10.2147/CIA.S45382.
- [45] Pe ML, Koval P, Kuppens P. Executive well-being: updating of positive stimuli in working memory is associated with subjective well-being. *Cognition.* 2013;126:335–40. doi:10.1016/j.cognition.2012.10.002.
- [46] Hansson I, Buratti S, Thorvaldsson V, Johansson B, Berg AI, Henkens K. Changes in life satisfaction in the retirement transition: interaction effects of transition type and individual resources. *Work Aging Retire.* 2018;4:352–66. doi:10.1093/workar/wax025.
- [47] Siedlecki KL, Tucker-Drob EM, Oishi S, Salthouse TA. Life satisfaction across adulthood: different determinants at different ages? *J Posit Psychol.* 2008;3:153–64. doi:10.1080/17439760701834602.
- [48] St John PD, Montgomery PR. Cognitive impairment and life satisfaction in older adults. *Int J Geriatr Psychiatry.* 2010;25:814–21. doi:10.1002/gps.2422.
- [49] Toh WX, Yang H. Executive function moderates the effect of reappraisal on life satisfaction: a latent variable analysis. *Emotion.* 2020; doi:10.1037/emo0000907.
- [50] Ghisletta P, McArdle JJ. Teacher's corner: latent curve models and latent change score models estimated in R. *Struct Equ Model.* 2012;19:651–82. doi:10.1080/10705511.2012.713275.
- [51] Hamaker EL, Kuiper RM, Grasman RPPP. A critique of the cross-lagged panel model. *Psychol Methods.* 2015;20:102–16. doi:10.1037/a0038889.
- [52] Zainal NH, Newman MG. Relation between cognitive and behavioral strategies and future change in common mental health problems across 18 years. *J Abnorm Psychol.* 2019;128:295–304. doi:10.1037/abn0000428.
- [53] McArdle JJ, Grimm KJ. Five steps in latent curve and latent change score modeling with longitudinal data. In: van Montfort K, Oud JHL, Satorra A, editors. *Longitudinal research with latent variables.* Berlin–Heidelberg: Springer; 2010, p. 245–73. doi:10.1007/978-3-642-11760-2_8.
- [54] Usami S, Hayes T, McArdle JJ. Inferring longitudinal relationships between variables: model selection between the latent change score and autoregressive cross-lagged factor models. *Struct Equ Model.* 2015;23:331–42. doi:10.1080/10705511.2015.1066680.
- [55] Klopick ET, Wickrama K. Modeling latent change score analysis and extensions in Mplus: a practical guide for researchers. *Struct Equ Model.* 2020;27:97–110. doi:10.1080/10705511.2018.1562929.
- [56] Cui L, Hou NN, Wu HM, Zuo X, Lian YZ, Zhang CN, et al. Prevalence of Alzheimer's disease and Parkinson's disease in China: an updated systematic analysis. *Front Aging Neurosci.* 2020;12:603854. doi:10.3389/fnagi.2020.603854.
- [57] Harvey SB, Deady M, Wang M-J, Mykletun A, Butterworth P, Christensen H, et al. Is the prevalence of mental illness increasing in Australia? Evidence from national health surveys and administrative data, 2001–2014. *Med J Aust.* 2017;206:490–3. doi:10.5694/mja16.00295.
- [58] Martyr A, Nelis SM, Quinn C, Wu YT, Lamont RA, Henderson C, et al. Living well with dementia: a systematic review and correlational meta-analysis of factors associated with quality of life, well-being and life satisfaction in people with dementia. *Psychol Med.* 2018;48:2130–9. doi:10.1017/S0033291718000405.
- [59] Wright AGC, Woods WC. Personalized models of psychopathology. *Annu Rev Clin Psychol.* 2020;16:49–74. doi:10.1146/annurev-clinpsy-102419-125032.
- [60] American Psychiatric Association. *Diagnostic and statistical manual of mental disorders.* 3rd rev. ed. Washington, DC: American Psychiatric Association; 1987.
- [61] Rizzuto D, Feldman AL, Karlsson IK, Dahl Aslan AK, Gatz M, Pedersen NL. Detection of dementia cases in two Swedish health registers: a validation study. *J Alzheimers Dis.* 2018;61:1301–10. doi:10.3233/JAD-170572.
- [62] Petkus AJ, Reynolds CA, Wetherell JL, Kremen WS, Gatz M. Temporal dynamics of cognitive performance and anxiety across older adulthood. *Psychol Aging.* 2017;32:278–92. doi:10.1037/pag0000164.
- [63] Wood V, Wylie ML, Sheafor B. An analysis of a short self-report measure of life satisfaction: correlation with rater judgments. *J Gerontol.* 1969;24:465–9. doi:10.1093/geronj/24.4.465.
- [64] Harris JR, Pedersen NL, Stacey C, McClearn GE, Nesselrode JR. Age differences in the etiology of the relationship between life satisfaction and self-rated health. *J Aging Health.* 1992;4:349–68. doi:10.1177/089826439200400302.

- [65] Lehto K, Karlsson I, Lundholm C, Pedersen NL. Genetic risk for neuroticism predicts emotional health depending on childhood adversity. *Psychol Med*. 2019;49:260–7. doi:10.1017/S0033291718000715.
- [66] Wechsler, D. Wechsler's measurement and appraisal of adult intelligence. 5th ed. Baltimore: Williams & Wilkins; 1972.
- [67] Brand HJ, Pieterse MJ, Frost M. Reliability and validity of the Ohwaki-Kohs tactile block design test for the blind. *Psychol Rep*. 1986;58:375–80. doi:10.2466/pr0.1986.58.2.375.
- [68] Finkel D, Reynolds CA, McArdle JJ, Pedersen NL. Age changes in processing speed as a leading indicator of cognitive aging. *Psychol Aging*. 2007;22:558–68. doi:10.1037/0882-7974.22.3.558.
- [69] Pahlen S, Hamdi NR, Dahl Aslan AK, Horwitz BN, Panizzon MS, Petersen I, et al. Age-moderation of genetic and environmental contributions to cognitive functioning in mid- and late-life for specific cognitive abilities. *Intelligence*. 2018;68:70–81. doi:10.1016/j.intell.2017.12.004.
- [70] Smith A. Symbol digit modalities test. Los Angeles: Western Psychological Services; 1982.
- [71] Strober LB, Bruce JM, Arnett PA, Alschuler KN, Lebkuecher A, Di Benedetto M, et al. A new look at an old test: normative data of the symbol digit modalities test—Oral version. *Mult Scler Relat Disord*. 2020;43:102154. doi:10.1016/j.msard.2020.102154.
- [72] Chen KW, Lee YC, Yu TY, Cheng LJ, Chao CY, Hsieh CL. Test-retest reliability and convergent validity of the test of nonverbal intelligence-fourth edition in patients with schizophrenia. *BMC Psychiatry*. 2021;21:39. doi:10.1186/s12888-021-03041-4.
- [73] Strober L, DeLuca J, Benedict RHB, Jacobs A, Cohen JA, Chiaravalloti N, et al. Symbol digit modalities test: a valid clinical trial endpoint for measuring cognition in multiple sclerosis. *Mult Scler J*. 2018;25:1781–90. doi:10.1177/1352458518808204.
- [74] Wechsler D. Wechsler adult intelligence scale-fourth edition: technical and interpretative manual. San Antonio, TX: Pearson Assessment; 2008.
- [75] Hilbert S, Nakagawa TT, Puci P, Zech A, Bühner M. The digit span backwards task. *Eur J Psychol Assess*. 2015;31:174–80. doi:10.1027/1015-5759/a000223.
- [76] Ryan JJ, Townsend JM, Kreiner DS. Comparison of oral, written, and pointing responses to WAIS-IV digit span. *Appl Neuropsychol Adult*. 2014;21:94–7. doi:10.1080/09084282.2012.753076.
- [77] R Core Team. R: a language and environment for statistical computing. R Foundation for Statistical Computing, Vienna, Austria, <https://www.R-project.org/>; 2020.
- [78] Revelle W. psych: Procedures for personality and psychological research, Northwestern University, Evanston, Illinois, USA, <https://CRAN.R-project.org/package=psych>, Version = 2.1.6; 2021.
- [79] Bentler PM. Comparative fit indexes in structural models. *Psychol Bull*. 1990;107:238–46. doi:10.1037/0033-2909.107.2.238.
- [80] Steiger JH. Structural model evaluation and modification: an interval estimation approach. *Multivar Behav Res*. 1990;25:173–80. doi:10.1207/s15327906mbr2502_4.
- [81] Oberski D. lavaan.survey: An R package for complex survey analysis of structural equation models. *J Stat Softw*. 2014;57:27. doi:10.18637/jss.v057.i01.
- [82] Graham JW. Missing data analysis: making it work in the real world. *Annu Rev Psychol*. 2009;60:549–76. doi:10.1146/annurev.psych.58.110405.085530.
- [83] MacDonald SW, Stawski RS. Chapter 2: methodological considerations for the study of adult development and aging. In Schaie KW, Willis SL, editors. *Handbook of the psychology of aging*. 8th ed. San Diego: Academic Press; 2016, p. 3–13. doi:10.1016/B978-0-12-411469-2.00001-7.
- [84] Lee T, Shi D. A comparison of full information maximum likelihood and multiple imputation in structural equation modeling with missing data. *Psychol Methods*. 2021;26:466–85. doi:10.1037/met0000381.
- [85] Madley-Dowd P, Hughes R, Tilling K, Heron J. The proportion of missing data should not be used to guide decisions on multiple imputation. *J Clin Epidemiol*. 2019;110:63–73. doi:10.1016/j.jclinepi.2019.02.016.
- [86] Widaman KF, Ferrer E, Conger RD. Factorial invariance within longitudinal structural equation models: measuring the same construct across time. *Child Dev Perspect*. 2010;4:10–8. doi:10.1111/j.1750-8606.2009.00110.x.
- [87] Cheung GW, Rensvold RB. Evaluating goodness-of-fit indexes for testing measurement invariance. *Struct Equ Model*. 2002;9:233–55. doi:10.1207/s15328007sem0902_5.
- [88] Zainal NH, Newman MG, Hong RY. Cross-cultural and gender invariance of transdiagnostic processes in the United States and Singapore. *Assessment*. 2021;28:485–502. doi:10.1177/1073191119869832.
- [89] Grimm KJ, Ram N. Latent growth and dynamic structural equation models. *Annu Rev Clin Psychol*. 2018;14:55–89. doi:10.1146/annurev-clinpsy-050817-084840.
- [90] Matusik JG, Hollenbeck JR, Mitchell RL. Latent change score models for the study of development and dynamics in organizational research. *Organ Res Methods*. 2020;24:772–801. doi:10.1177/1094428120963788.
- [91] McArdle JJ. Latent variable modeling of differences and changes with longitudinal data. *Annu Rev Psychol*. 2009;60:577–605. doi:10.1146/annurev.psych.60.110707.163612.
- [92] Sardeshmukh SR, Vandenberg RJ. Integrating moderation and mediation. *Organ Res Methods*. 2016;20:721–45. doi:10.1177/1094428115621609.
- [93] Ke Z, Wang L. Detecting individual differences in change: methods and comparisons. *Struct Equ Model*. 2014;22:382–400. doi:10.1080/10705511.2014.936096.
- [94] Wang L, Yang M. On interindividual differences in intraindividual changes. In: Emilio F, Steven MB, Kevin JG, editors. *Longitudinal multivariate psychology*. Milton: Routledge; 2018, p. 166–88. doi:10.4324/9781315160542-9.
- [95] Dunlap WP, Cortina JM, Vaslow JB, Burke MJ. Meta-analysis of experiments with matched groups or repeated measures designs. *Psychol Methods*. 1996;1:170–7. doi:10.1037/1082-989x.1.2.170.
- [96] Zhang Z, Hamagami F, Grimm KJ, McArdle JJ. Using R package RAM-path for tracing SEM path diagrams and conducting complex longitudinal data analysis. *Struct Equ Model*. 2015;22:132–47. doi:10.1080/10705511.2014.935257.
- [97] Ottaviani C, Thayer JF, Verkuil B, Lonigro A, Medea B, Couyoumdjian A, et al. Physiological concomitants of perseverative cognition: a systematic review and meta-analysis. *Psychol Bull*. 2016;142:231–59. doi:10.1037/bul0000036.
- [98] Zainal NH, Newman MG. Depression and worry symptoms predict future executive functioning impairment via inflammation. *Psychol Med*. 2021;1–11. doi:10.1017/S0033291721000398.
- [99] Eckstrand KL, Forbes EE, Bertocci MA, Chase HW, Greenberg T, Lockovich J, et al. Anhedonia reduction and the association between left ventral striatal reward response and 6-month improvement in life satisfaction among young adults. *JAMA Psychiat*. 2019;76:958–65. doi:10.1001/jamapsychiatry.2019.0864.
- [100] Kong F, Ding K, Yang Z, Dang X, Hu S, Song Y, et al. Examining gray matter structures associated with individual differences in global life satisfaction in a large sample of young adults. *Soc Cogn Affect Neurosci*. 2015;10:952–60. doi:10.1093/scan/nsu144.
- [101] Waldinger RJ, Kensinger EA, Schulz MS. Neural activity, neural connectivity, and the processing of emotionally valenced information in older adults: links with life satisfaction. *Cogn Affect Behav Neurosci*. 2011;11:426–36. doi:10.3758/s13415-011-0039-9.
- [102] Birren JE, Schaie KW. *Handbook of the psychology of aging*. 6th ed. United States of America, Academic Press; 2006.
- [103] Salthouse TA. The processing-speed theory of adult age differences in cognition. *Psychol Rev*. 1996;103:403–28. doi:10.1037/0033-295X.103.3.403.
- [104] Baddeley A. Working memory and emotion: ruminations on a theory of depression. *Rev Gen Psychol*. 2013;17:20–7. doi:10.1037/a0030029.
- [105] Wang J, Zhu WH, Li YF, Zhu WW. Temporal precedence of cognitive function and functional abilities: a latent difference score model of the Chinese community-dwelling elders. *Int J Geriatr Psychiatry*. 2019;34:1892–9. doi:10.1002/gps.5206.
- [106] Fisher AJ, Medaglia JD, Jeronimus BF. Lack of group-to-individual generalizability is a threat to human subjects research. *Proc Natl Acad Sci*. 2018;115:E6106–15. doi:10.1073/pnas.1711978115.

- [107] Jaywant A, Barredo J, Ahern DC, Resnik L. Neuropsychological assessment without upper limb involvement: a systematic review of oral versions of the trail making test and symbol-digit modalities test. *Neuropsychol Rehabil.* 2018;28:1055–77. doi:10.1080/09602011.2016.1240699.
- [108] Dohle S, Hofmann W. Consistency and balancing in everyday health behaviour: an ecological momentary assessment approach. *Appl Psychol Health Well Being.* 2019;11:148–69. doi:10.1111/aphw.12148.
- [109] Smyth JM, Zawadzki MJ, Juth V, Sciamanna CN. Global life satisfaction predicts ambulatory affect, stress, and cortisol in daily life in working adults. *J Behav Med.* 2017;40:320–31. doi:10.1007/s10865-016-9790-2.
- [110] Foong HF, Haron SA, Koris R, Hamid TA, Ibrahim R. Relationship between financial well-being, life satisfaction, and cognitive function among low-income community-dwelling older adults: the moderating role of sex. *Psychogeriatrics.* 2021;21:586–95. doi:10.1111/psyg.12709.
- [111] Johansson B, Björk MP, Thorvaldsson V. I rate my memory quite similar at age 40 and at age 70. *GeroPsych.* 2020;33:235–44. doi:10.1024/1662-9647/a000239.
- [112] Schuster RM, Mermelstein RJ, Hedeker D. Acceptability and feasibility of a visual working memory task in an ecological momentary assessment paradigm. *Psychol Assess.* 2015;27:1463–70. doi:10.1037/pas0000138.
- [113] Abramovitch A, Short T, Schweiger A. The C factor: Cognitive dysfunction as a transdiagnostic dimension in psychopathology. *Clin Psychol Rev.* 2021;86:102007. doi:10.1016/j.cpr.2021.102007.
- [114] Liao KY, Weng CY. Gratefulness and subjective well-being: social connectedness and presence of meaning as mediators. *J Couns Psychol.* 2018;65:383–93. doi:10.1037/cou0000271.
- [115] Bäckman LDHR, Herlitz A, Robins-Wahlin T-B, Wahlin Å, Winblad B. Verbal and nonverbal episodic memory performance in a 2-year longitudinal study of optimally healthy very old adults. *J Men Health Aging.* 1998;4:139–54.
- [116] Hultsch DF, Hertzog C, Small BJ, McDonald-Miszczak L, Dixon RA. Short-term longitudinal change in cognitive performance in later life. *Psychol Aging.* 1992;7:571–84. doi:10.1037/0882-7974.7.4.571.
- [117] Rönnlund M, Nyberg L, Bäckman L, Nilsson LG. Stability, growth, and decline in adult life span development of declarative memory: cross-sectional and longitudinal data from a population-based study. *Psychol Aging.* 2005;20:3–18. doi:10.1037/0882-7974.20.1.3.
- [118] MacLean KA, Ferrer E, Aichele SR, Bridwell DA, Zanesco AP, Jacobs TL, et al. Intensive meditation training improves perceptual discrimination and sustained attention. *Psychol Sci.* 2010;21:829–39. doi:10.1177/0956797610371339.
- [119] Shields GS, Skwara AC, King BG, Zanesco AP, Dhabhar FS, Saron CD. Deconstructing the effects of concentration meditation practice on interference control: the roles of controlled attention and inflammatory activity. *Brain Behav Immun.* 2020;89:256–67. doi:10.1016/j.bbi.2020.06.034.
- [120] Zainal NH, Newman MG. Mindfulness enhances cognitive functioning: A meta-analysis of 111 randomized controlled trials. in preparation; doi:10.31234/osf.io/vzxxw7.
- [121] Jha AP, Zanesco AP, Denkova E, Morrison AB, Ramos N, Chichester K, et al. Bolstering cognitive resilience via train-the-trainer delivery of mindfulness training in applied high-demand settings. *Mindfulness.* 2019;11:683–97. doi:10.1007/s12671-019-01284-7.
- [122] Jha AP, Zanesco AP, Denkova E, Rooks J, Morrison AB, Stanley EA. Comparing mindfulness and positivity trainings in high-demand cohorts. *Cogn Ther Res.* 2020;44:311–26. doi:10.1007/s10608-020-10076-6.
- [123] Jazaieri H, Goldin PR, Gross JJ. Treating social anxiety disorder with CBT: impact on emotion regulation and satisfaction with life. *Cogn Ther Res.* 2016;41:406–16. doi:10.1007/s10608-016-9762-4.
- [124] Samaan M, Diefenbacher A, Schade C, Dambacher C, Pontow IM, Pakenham K, et al. A clinical effectiveness trial comparing ACT and CBT for inpatients with depressive and mixed mental disorders. *Psychother Res.* 2021;31:355–68. doi:10.1080/10503307.2020.1802080.
- [125] Shahidi M, Mojtahed A, Modabbernia A, Mojtahed M, Shafiabady A, Delavar A, et al. Laughter yoga versus group exercise program in elderly depressed women: a randomized controlled trial. *Int J Geriatr Psychiatry.* 2011;26:322–7. doi:10.1002/gps.2545.
- [126] Shatil E, Mikulecka J, Bellotti F, Bures V. Novel television-based cognitive training improves working memory and executive function. *PLoS One.* 2014;9:e101472. doi:10.1371/journal.pone.0101472.
- [127] Sok S, Shin E, Kim S, Kim M. Effects of cognitive/exercise dual-task program on the cognitive function, health status, depression, and life satisfaction of the elderly living in the community. *Int J Environ Res Public Health.* 2021;18:7848. doi:10.3390/ijerph18157848.
- [128] Wu LF, Koo M. Randomized controlled trial of a six-week spiritual reminiscence intervention on hope, life satisfaction, and spiritual well-being in elderly with mild and moderate dementia. *Int J Geriatr Psychiatry.* 2016;31:120–7. doi:10.1002/gps.4300.
- [129] Buijnicks SJE, Meeter M, Lemmens LHJM, Peeters F, Cuijpers P, Huibers MJH. Temporal and specific pathways of change in cognitive behavioral therapy (CBT) and interpersonal psychotherapy (IPT) for depression. *Behav Res Ther.* 2022;151:104010. doi:10.1016/j.brat.2021.104010.