

Synchronous endometrial and ovarian cancer in Lynch syndrome with a *MSH2* germline mutation: A case report

TAKASHI TAKEDA, KOUJI BANNO, MEGUMI YANOKURA, MAYUKA ANKO, ARATA KOBAYASHI, ASAKO SERA, TAKAYUKI TAKAHASHI, MASATAKA ADACHI, YUSUKE KOBAYASHI, SHIGENORI HAYASHI, HIROYUKI NOMURA, AKIRA HIRASAWA, EIICHIRO TOMINAGA and DAISUKE AOKI

Department of Obstetrics and Gynecology, Keio University School of Medicine, Tokyo 160-8582, Japan

Received July 19, 2018; Accepted September 17, 2018

DOI: 10.3892/mco.2018.1723

Abstract. Synchronous endometrial and ovarian cancer (SEOC) is a rare entity among gynecological cancers, which exhibits endometrioid histology in its early stages and generally has a good prognosis. However, diagnosis is difficult and recent reports have demonstrated that most clinically diagnosed cases of SEOC have clonally related cancers, indicating metastatic cancer. The association of SEOC with Lynch syndrome is also not clearly understood. We herein present the case of a 41-year-old SEOC patient with *MSH2* mutation. The endometrial cancer was an endometrioid adenocarcinoma and the ovarian cancer was mainly endometrioid, but also included a clear cell carcinoma with a borderline clear cell adenofibromatous component, indicating primary ovarian cancer. Both tumors exhibited microsatellite instability (MSI) and loss of expression of *MSH2* and *MSH6*. The patient had a family history of colorectal and gastric cancers. Genetic analysis revealed a germline mutation in exon 6 of *MSH2* (c.1042C>T, p.Gln348*) and the patient was diagnosed with Lynch syndrome. This *MSH2* mutation has only been registered in one case in the InSiGHT variant databases and has not been reported in a gynecological tumor or SEOC to date. This case is a rare example of a patient with genetically diagnosed Lynch syndrome who also developed SEOC. This synchronous cancer is not common, but it may be caused by Lynch syndrome. Testing for MSI and immunohistochemistry for mismatch repair deficiency is necessary in cases with suspected SEOC.

Introduction

Co-occurrence of carcinoma in the uterus and ovary is found in ~5% of cases of endometrial cancer and 10% of ovarian cancer (1,2). Synchronous endometrial and ovarian cancer (SEOC) accounts for 50-70% of all synchronous female genital cancers, and ~1-2% of all women with gynecological cancers have simultaneous primary tumors involving the genital tract (3,4). SEOC is usually diagnosed at its early stages, which results in a good prognosis (5,6). Another characteristic of SEOC is that both the endometrial and ovarian cancers have mainly endometrioid histology (2). In such cases, differential diagnoses include primary SEOC with stage I endometrioid endometrial cancer and endometrioid ovarian cancer, stage III metastatic endometrioid endometrial cancer to the ovary, and stage II metastatic endometrioid ovarian cancer to the endometrium. The Ulbright and Roth criteria are commonly used to distinguish SEOC from metastatic endometrial or ovarian cancer (7).

The correlation of Lynch syndrome with SEOC is not well understood. Several studies have reported that Lynch syndrome is not common in patients with SEOC, and it is estimated that ~3-14% of SEOC cases are caused by Lynch syndrome (8-10). By contrast, 17-30% of cases of synchronous or metachronous endometrial and colorectal cancers are caused by Lynch syndrome (11,12). However, the prevalence of Lynch syndrome in SEOC is more frequent compared with that in endometrial or ovarian cancer. Furthermore, a double primary Lynch-associated cancer with a family history shows a high prevalence of Lynch syndrome, and it is important to test for microsatellite instability (MSI) or expression of mismatch repair (MMR) proteins by immunohistochemistry (IHC) in such cases (13). We herein report a case of SEOC (endometrial endometrioid adenocarcinoma and ovarian mixed endometrioid and clear cell carcinoma) with a *MSH2* mutation.

Case report

A 41-year-old woman with abnormal genital bleeding and hypermenorrhea was referred to the Department of Obstetrics and Gynecology of Keio University School of Medicine (Tokyo, Japan) from a gynecological outpatient clinic in May, 2016. The patient had anemia (hemoglobin 6.5 g/dl), and transvaginal

Correspondence to: Dr Kouji Banno, Department of Obstetrics and Gynecology, Keio University School of Medicine, Shinanomachi 35, Shinjyuku-ku, Tokyo 160-8582, Japan
E-mail: kbanno@z7.keio.jp

Abbreviations: SEOC, synchronous endometrial and ovarian cancer; MMR, mismatch repair; MSI, microsatellite instability; IHC, immunohistochemistry; MLPA, multiplex ligation-dependent probe amplification

Key words: synchronous cancer, endometrial cancer, ovarian cancer, Lynch syndrome, *MSH2* germline mutation

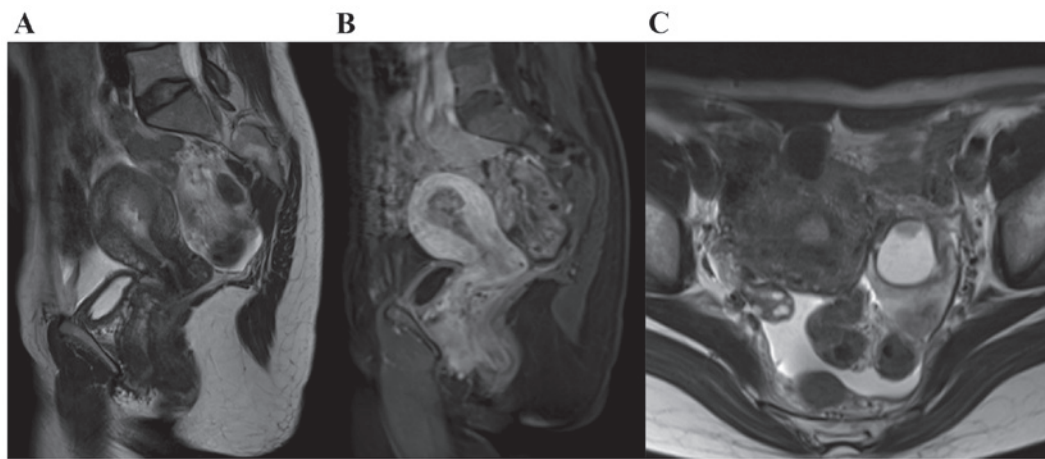

Figure 1. Pelvic magnetic resonance imaging: (A) T2-weighted sagittal, (B) T1-enhanced sagittal and (C) T2-weighted horizontal. (A and B) Endometrial tumor exhibiting invasive growth into the myometrium. (C) Left ovarian tumor with a solid component.

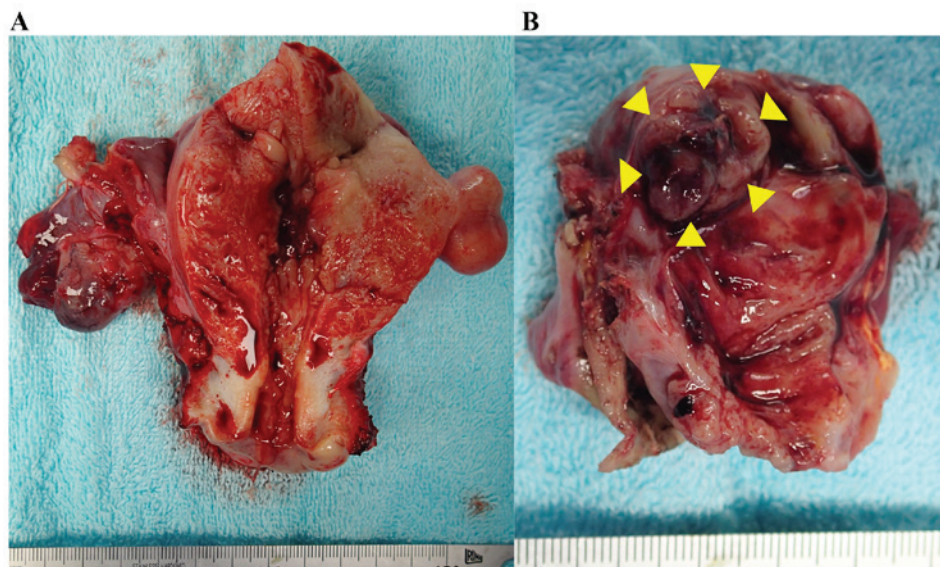

Figure 2. Macroscopic appearance of the resected uterus and ovaries. (A) Uterus: The endometrial tumor grossly invaded the myometrium. (B) Left ovary: The left ovarian tumor included a 30-mm solid component (arrowheads).

ultrasonography revealed thickened (20 mm) endometrium and swelling (34 mm) of the left ovary with a solid component. The findings on cervical cytology were atypical glandular cells, favor neoplastic (AGC-FN), indicating contamination by endometrial cells, and endometrial cytology was positive, suggesting endometrioid adenocarcinoma. Endometrial curettage revealed endometrial endometrioid adenocarcinoma grade 2. The tumor markers carbohydrate antigen (CA) 19-9 and CA125 were elevated (118 and 52 U/ml, respectively; normal range: <37 and <35 U/ml, respectively), whereas the carcinoembryonic antigen level was normal (0.9 ng/ml). Positron emission tomography/computed tomography revealed no distant metastasis, but contrast-enhanced pelvic magnetic resonance imaging examination revealed invasion of over half of the thickness of the myometrium by endometrial cancer and enlargement of the left ovary to 30 mm with an enhanced solid component (Fig. 1). These findings indicated that the pelvic tumor was SEOC, or endometrial cancer with ovarian metastasis.

During surgery, the uterus and left ovary were grossly enlarged and there was no abdominal metastasis. A frozen section diagnosis of the left ovarian tumor revealed adenocarcinoma with a clear cell component, indicating primary ovarian cancer. Extended total hysterectomy, bilateral salpingo-oophorectomy, pelvic and para-aortic lymphadenectomy, omentectomy, and peritoneal biopsies were performed (Fig. 2). Surgery was completed without any complications or the need for blood transfusion, and the patient was discharged from the hospital 1 week after the operation.

The pathological findings included endometrial endometrioid adenocarcinoma G2 and ovarian mixed endometrioid and clear cell carcinoma. There was no metastasis to the omentum or peritoneum, but there were metastases to the right obturator and left para-aortic lymph nodes. Endometrial adenocarcinoma had invaded almost half of the myometrium and also exhibited lymphovascular invasion. Finally, the diagnosis was synchronous International Federation of Gynecology and Obstetrics (FIGO) stage IIIC2 endometrial endometrioid

Table I. Pathological findings and the diagnosis of this case.

Location	Tumor characteristics
Uterus	Endometrioid adenocarcinoma G2 with squamous differentiation, 45x42 mm in size, myometrial invasion 12/26 mm ly (+), v (-), invasion to cervix (-), surface exposure (-), margin (-)
Ovary (left)	Mixed epithelial carcinoma (endometrioid G1+ clear cell carcinoma), 30x25x19 mm in size, ly (-), v (-), surface exposure (-)
Ovary (right)	Borderline clear cell adenofibroma (4x3 mm in size)
Omentum	No metastasis
Lymph nodes (pelvic)	Metastasis to a right obturator lymph node (1/37)
Lymph nodes (para-aortic)	Metastasis of carcinoma to left 326b1 (above inferior mesenteric artery) Lymph node status, 1/27
Peritoneal biopsy	No metastasis
Ascites	Negative

The final diagnosis was endometrial cancer stage IIIC and ovarian cancer stage IA (the lymph node metastases were from the endometrial cancer as indicated by the myometrial and lymphatic invasion).

adenocarcinoma, and FIGO stage IA ovarian endometrioid and clear cell carcinoma (Table I). Due to the high risk of recurrence, adjuvant chemotherapy with paclitaxel (175 mg/m²) and carboplatin (area under the curve=6) was administered once every three weeks for six cycles. The patient is currently being followed up and remained recurrence-free at the most recent follow-up appointment in April, 2018.

The patient had a family history of colorectal and gastric cancers, as well as young onset of SEOC, and Lynch syndrome was suspected (Fig. 3). Therefore, MSI was analyzed for 5 markers (NR21, NR24, BAT25, BAT26, MONO27) and all were positive (MSI-high). IHC was performed for MLH1, MSH2, MSH6 and PMS2. All the cancer components (endometrial endometrioid adenocarcinoma, ovarian endometrioid carcinoma and ovarian clear cell carcinoma) exhibited loss of MSH2 and MSH6 expression (Fig. 4). These results indicated a *MSH2* germline mutation or *MSH2* epimutation due to an EPCAM mutation. Following detailed genetic counseling, we performed a genetic test for MMR genes, namely *MLH1*, *MSH2*, *MSH6* and *PMS2*. reverse transcription-polymerase chain reaction (PCR) was performed, and the results were confirmed by direct sequencing using genomic DNA. Furthermore, we checked for a large rearrangement by multiplex ligation-dependent probe amplification (MLPA) for *MLH1*, *MSH2*, *MSH6* and *PMS2*. Additionally, the methylation status of CpG islands in the *MLH1*, *MSH2* and *MSH6* promoters was analyzed by methylation-specific PCR. There was no large rearrangement, and methylation for tested genes and direct sequencing revealed a germline mutation in exon 6 of *MSH2* (c.1042C>T, p.Gln348*), confirming the diagnosis of Lynch syndrome (Fig. 5).

Discussion

Lynch syndrome accounts for 2-6% of endometrial cancers and 0.4-1.0% of ovarian cancers (14,15). The cumulative lifetime risks of endometrial and ovarian cancer are ~28-60

and 6-14%, respectively, in female patients with Lynch syndrome (16-18). However, the risk of SEOC in the context of this syndrome is uncertain, although it has been suggested that ~3-14% of SEOC cases exhibit a causative association with Lynch syndrome (8-10). Synchronous or metachronous Lynch-associated cancer with a family history shows a high prevalence of Lynch syndrome (13), and our patient had SEOC with a family history of Lynch-associated cancers. The calculated risk of Lynch syndrome by the PREMM5 prediction model was 26.3%. The patient in the present case had an endometrioid carcinoma component in the endometrial and ovarian cancers, consistent with a previous report that SEOC tends to include endometrioid components in both cancers (2). The majority of clinically diagnosed SEOC cases also have clonally related cancers, which probably reflects dissemination from one site to the other (19,20). However, our patient had a clear cell component in the left ovarian cancer and a right ovarian borderline clear cell adenofibroma, which made it easy to diagnose the case as SEOC, rather than metastatic ovarian cancer.

Endometrial cancer with Lynch syndrome is mainly caused by a *MSH2* or *MSH6* mutation, whereas ovarian cancer with Lynch syndrome is mainly caused by a *MSH2* mutation (21,22). It is also likely that *MSH2* and *MSH6* mutations may be the main cause of SEOC based on the frequency of these mutations in endometrial or ovarian cancer. Some reports have linked *MLH1*, *MSH2* and *MSH6* to SEOC, but the available data are limited (9,10,23). In addition, the only entries in the InSiGHT database registered for synchronous or metachronous endometrial and ovarian cancer are two *MLH1* variants, two *MLH3* variants, and one *MSH6* variant (*MLH1*: c.1162dup, c.1852_1854del; *MLH3*: c.1939C>T, c.2449A>G; and *MSH6*: c.3632T>C) (<https://www.insight-group.org/variants/databases/>). The mutation detected in the present case (*MSH2* exon6, c.1042C>T, p.Gln348*) is registered only for one case in InSiGHT, and this report did not mention the cancer origin (24). This mutation is not classified as either

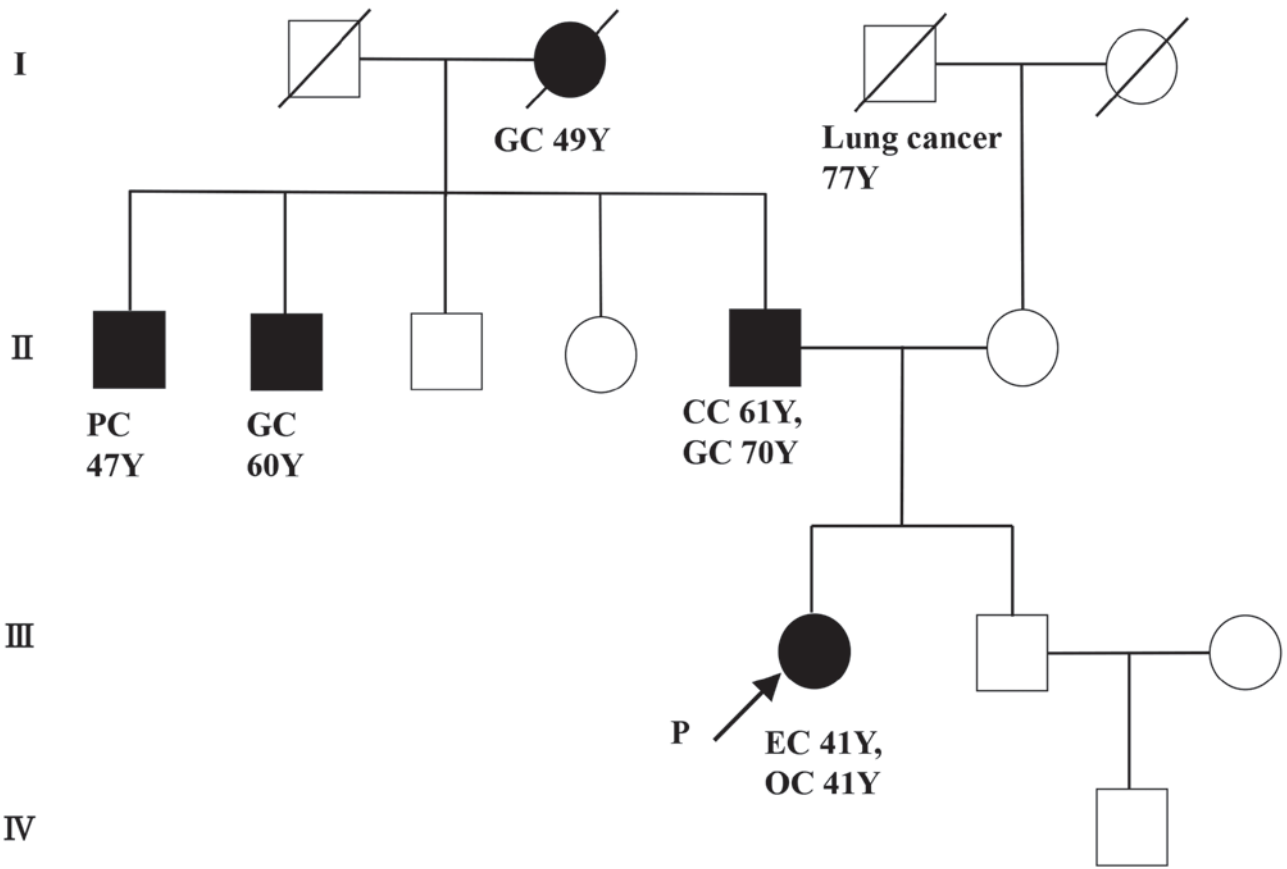

Figure 3. Family tree of this case. The patient had synchronous endometrial and ovarian cancer at 41 years of age. Her father had colorectal cancer and gastric cancer and her second-degree relatives also had gastric cancer and pancreatic cancer. The numbers below the symbols indicate age at diagnosis. EC, endometrial cancer; OC, ovarian cancer; CC, colorectal cancer; GC, gastric cancer; PC, pancreatic cancer.

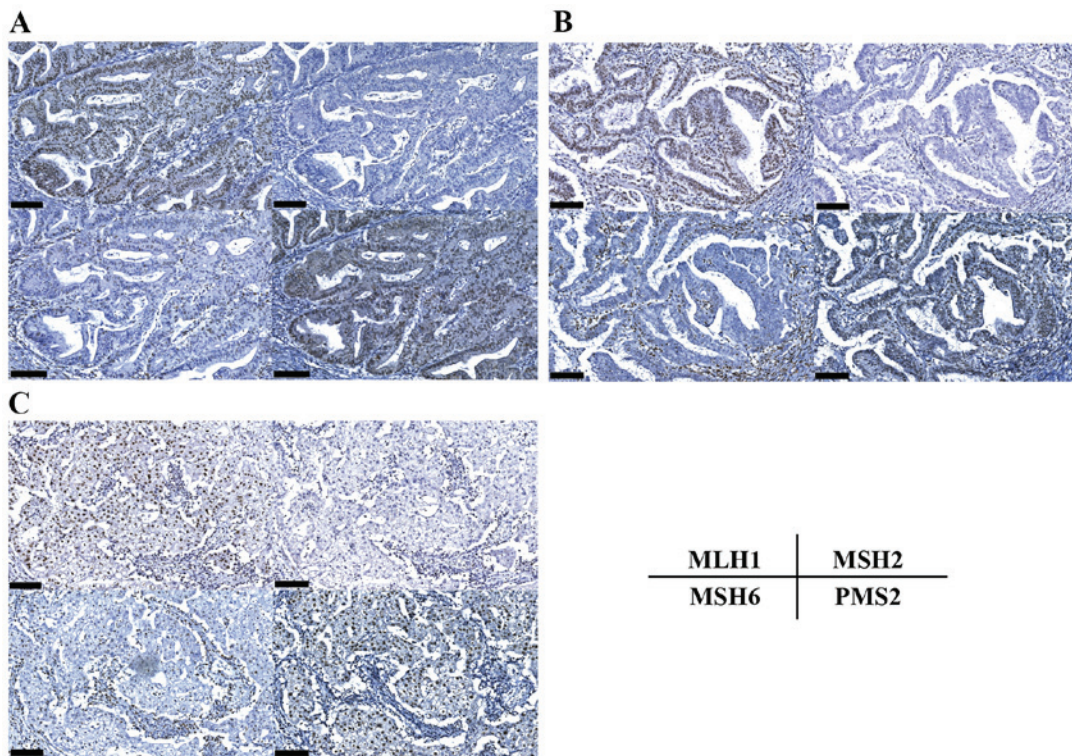

Figure 4. Immunohistochemistry of endometrial and ovarian cancer. (A) Endometrial endometrioid adenocarcinoma exhibiting loss of expression of MSH2 and MSH6, (B) ovarian endometrioid carcinoma and (C) ovarian clear cell carcinoma; both components of the ovarian cancer exhibited loss of expression of MSH2 and MSH6. Original magnification x20; scale bar, 100 μ m. All primary antibodies were from Dako, Santa Clara, CA, USA [MLH1 (M3640), MSH2 (M3639), MSH6 (M3646) and PMS2 (M3647)].

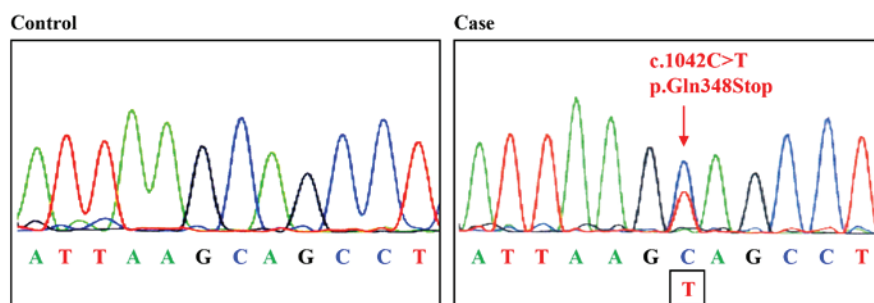

Figure 5. Direct sequence analysis of *MSH2*. A non-sense mutation was identified at codon 348 in exon 2 (c.1042C>T, p.Gln348*).

pathogenic or non-pathogenic in InSiGHT, but is classified as class 5 (pathogenic) in the original report (24). The mutation stops translation at position 348 of the 934 amino acids of *MSH2*, and this region serves as the *MSH3/MSH6* interaction domain. Therefore, it appears to be appropriate to classify this mutation as pathogenic.

To the best of our knowledge, this is the first reported case of the c.1042C>T *MSH2* mutation in a gynecological tumor or SEOC. Lynch syndrome in SEOC is not common, but is more often detected in SEOC compared with general endometrial cancer cases. Given that universal screening for endometrial cancer is becoming a standard practice and SEOC would be a high risk of Lynch syndrome, as stated in our previous report on screening for Lynch syndrome in ovarian cancer, it is necessary to perform MSI or IHC analysis for all SEOC cases (25,26). Detecting MSI-H in SEOC may be helpful for the diagnosis of Lynch syndrome, as well as for the use of precision medicine for ovarian or endometrial cancer, including targeted therapy of anti-PD1/PDL1 for MSI-H cancer. Furthermore, since the frequency and tendency for MMR gene mutation are not clear in SEOC, use of IHC for examination of loss of MMR protein expression may be informative in identifying the gene carrying the mutation.

Acknowledgements

The authors gratefully acknowledge the financial support and the support from the patient for publication of this report.

Funding

The present study was supported by the Keio Gijuku Academic Development Fund, the Keio University Grant-in-Aid for Encouragement of Young Medical Scientists and JSPS KAKENHI Grant-in-Aid for Young Scientists (JP18K16812).

Availability of data and materials

The datasets used during the present study are included in this published article and are also available from the corresponding author on reasonable request.

Authors' contributions

TakasT wrote the manuscript, K.B. checked the manuscript, MY performed tumor tests, MA, AK, AS and TakayT collected clinical data, MA, YK and AH contributed to genetic coun-

seling, and HN, ET and DA supervised the study. All authors have read and approved the final version of this manuscript.

Ethics approval and consent to participate

The study was performed in accordance with the Declaration of Helsinki and principles of Good Clinical Practice. Samples and clinical data were obtained after approval of the Institutional Ethics Committee of Keio University (ID: 2007-0081). The patient provided written informed consent.

Patient consent for publication

This patient provided informed consent for the publication of the study details, including use of data and images.

Competing interests

The authors declare that they have no competing interests.

References

1. Kurman RJ, Carcangiu ML, Herrington CS and Young RH: WHO Classification of Tumours of Female Reproductive Organs. IARC WHO Classification of Tumours. International Agency for Research on Cancer, Lyon, 2014.
2. Zaino R, Whitney C, Brady MF, DeGeest K, Burger RA and Buller RE: Simultaneously detected endometrial and ovarian carcinomas—a prospective clinicopathologic study of 74 cases: A gynecologic oncology group study. *Gynecol Oncol* 83: 355-362, 2001.
3. Tong SY, Lee YS, Park JS, Bae SN, Lee JM and Namkoong SE: Clinical analysis of synchronous primary neoplasms of the female reproductive tract. *Eur J Obstet Gynecol Reprod Biol* 136: 78-82, 2008.
4. Singh N: Synchronous tumours of the female genital tract. *Histopathology* 56: 277-285, 2010.
5. Sozen H, Vatansever D, Iyibozkurt AC, Topuz S, Ozsurmeli M, Salihoglu Y, Guzelbey B and Berkman S: Clinicopathologic and survival analyses of synchronous primary endometrial and epithelial ovarian cancers. *J Obstet Gynaecol Res* 41: 1813-1819, 2015.
6. Matsuo K, Machida H, Frimer M, Marcus JZ, Pejovic T, Roman LD and Wright JD: Prognosis of women with stage I endometrioid endometrial cancer and synchronous stage I endometrioid ovarian cancer. *Gynecol Oncol* 147: 558-564, 2017.
7. Ulbright TM and Roth LM: Metastatic and independent cancers of the endometrium and ovary: A clinicopathologic study of 34 cases. *Hum Pathol* 16: 28-34, 1985.
8. Kobayashi Y, Nakamura K, Nomura H, Banno K, Irie H, Adachi M, Iida M, Umene K, Nogami Y, Masuda K, *et al*: Clinicopathologic analysis with immunohistochemistry for DNA mismatch repair protein expression in synchronous primary endometrial and ovarian cancers. *Int J Gynecol Cancer* 25: 440-446, 2015.

9. Kim MK, Song SY, Do IG, Kim SH, Choi CH, Kim TJ, Lee JW, Bae DS and Kim BG: Synchronous gynecologic malignancy and preliminary results of Lynch syndrome. *J Gynecol Oncol* 22: 233-238, 2011.
10. Soliman PT, Broaddus RR, Schmeler KM, Daniels MS, Gonzalez D, Slomovitz BM, Gershenson DM and Lu KH: Women with synchronous primary cancers of the endometrium and ovary: Do they have Lynch syndrome? *J Clin Oncol* 23: 9344-9350, 2005.
11. Millar AL, Pal T, Madlensky L, Sherman C, Temple L, Mitri A, Cheng H, Marcus V, Gallinger S, Redston M, *et al*: Mismatch repair gene defects contribute to the genetic basis of double primary cancers of the colorectum and endometrium. *Hum Mol Genet* 8: 823-829, 1999.
12. Planck M, Rambech E, Möslein G, Müller W, Olsson H and Nilbert M: High frequency of microsatellite instability and loss of mismatch-repair protein expression in patients with double primary tumors of the endometrium and colorectum. *Cancer* 94: 2502-2510, 2002.
13. Hirai Y, Banno K, Suzuki M, Ichikawa Y, Udagawa Y, Sugano K and Miki Y: Molecular epidemiological and mutational analysis of DNA mismatch repair (MMR) genes in endometrial cancer patients with HNPCC-associated familial predisposition to cancer. *Cancer Sci* 99: 1715-1719, 2008.
14. Norquist BM, Harrell MI, Brady MF, Walsh T, Lee MK, Gulsuner S, Bernards SS, Casadei S, Yi Q, Burger RA, *et al*: Inherited mutations in women with ovarian carcinoma. *JAMA Oncol* 2: 482-490, 2016.
15. Pal T, Permuth-Wey J, Kumar A and Sellers TA: Systematic review and meta-analysis of ovarian cancers: Estimation of microsatellite-high frequency and characterization of mismatch repair deficient tumor histology. *Clin Cancer Res* 14: 6847-6854, 2008.
16. Aarnio M, Sankila R, Pukkala E, Salovaara R, Aaltonen LA, de la Chapelle A, Peltomäki P, Mecklin JP and Järvinen HJ: Cancer risk in mutation carriers of DNA-mismatch-repair genes. *Int J Cancer* 81: 214-218, 1999.
17. Bonadona V, Bonaïti B, Olschwang S, Grandjouan S, Huiart L, Longy M, Guimbaud R, Buecher B, Bignon YJ, Caron O, *et al*: Cancer risks associated with germline mutations in *MLH1*, *MSH2* and *MSH6* genes in Lynch syndrome. *JAMA* 305: 2304-2310, 2011.
18. Watson P, Vasen HFA, Mecklin JP, Bernstein I, Aarnio M, Järvinen HJ, Myrholm T, Sunde L, Wijnen JT and Lynch HT: The risk of extra-colonic, extra-endometrial cancer in the Lynch syndrome. *Int J Cancer* 123: 444-449, 2008.
19. Chao A, Wu RC, Jung SM, Lee YS, Chen SJ, Lu YL, Tsai CL, Lin CY, Tang YH, Chen MY, *et al*: Implication of genomic characterization in synchronous endometrial and ovarian cancers of endometrioid histology. *Gynecol Oncol* 143: 60-67, 2016.
20. Schultheis AM, Ng CK, De Filippo MR, Piscuoglio S, Macedo GS, Gatiús S, Perez Mies B, Soslow RA, Lim RS, Viale A, *et al*: Massively parallel sequencing-based clonality analysis of synchronous endometrioid endometrial and ovarian carcinomas. *J Natl Cancer Inst* 108: djv427, 2016.
21. Schweizer P, Moïsio AL, Kuismanen SA, Truninger K, Vierumäki R, Salovaara R, Arola J, Butzow R, Jiricny J, Peltomäki P and Nyström-Lahti M: Lack of *MSH2* and *MSH6* characterizes endometrial but not colon carcinomas in hereditary nonpolyposis colorectal cancer. *Cancer Res* 61: 2813-2815, 2001.
22. Helder-Woolderink JM, Blok EA, Vasen HF, Hollema H, Mourits MJ and De Bock GH: Ovarian cancer in Lynch syndrome; a systematic review. *Eur J Cancer* 55: 65-73, 2016.
23. Dogan A, Schultheis B, Rezniczek GA, Hilal Z, Cetin C, Häusler G and Tempfer CB: Synchronous endometrial and ovarian cancer in young women: Case report and review of the literature. *Anticancer Res* 37: 969-978, 2017.
24. Sjursen W, McPhillips M, Scott RJ and Talseth-Palmer BA: Lynch syndrome mutation spectrum in New South Wales, Australia, including 55 novel mutations. *Mol Genet Genomic Med* 4: 223-231, 2016.
25. Gupta S, Provenzale D, Regenbogen SE, Hampel H, Slavin P Jr, Hall MJ, Llor X, Chung DC, Ahnen DJ, Bray T, *et al*: NCCN Guidelines Insights: Genetic/Familial High-Risk assessment: Colorectal, Version 3.2017. *J Natl Compr Canc Netw* 15: 1465-1475, 2017.
26. Takeda T, Tsuji K, Banno K, Yanokura M, Kobayashi Y, Tominaga E and Aoki D: Screening for Lynch syndrome using risk assessment criteria in patients with ovarian cancer. *J Gynecol Oncol* 29: e29, 2018.



This work is licensed under a Creative Commons Attribution-NonCommercial-NoDerivatives 4.0 International (CC BY-NC-ND 4.0) License.