

Iranian Health Information Technology Acceptance Model (IHITAM) from Users' Views

Mehrdad Farzandipour¹,
Somayyeh Nadi-Ravandi¹,
Hamidreza Gilasi¹, Nabiallah
Soleimani¹

¹Health Information Management Research
Center, Kashan University of Medical
Sciences, Kashan, Iran

Corresponding author: Somayyeh Nadi Ravandi,
Health Information Management Research
Center, Kashan University of Medical Sciences,
Kashan, I.R. Iran, 5th of Ootb –e Ravandi Blvd.
Phone: P.O.Box: 8715988141, Kashan, Iran,
Phone: 00989132613929, 009855542999,
E-mail: snadi2006@gmail.com, ORCID ID:
<https://www.orcid.org/0000-0002-6257-2325>

doi: 10.5455/aim.2019.27.245-252

ACTA INFORM MED. 2019 DEC 27(4): 245-252

Received: Oct 18, 2019 • Accepted: Dec 16, 2019

ABSTRACT

Introduction: Information technology (IT) is an important component of medical informatics. Information needs to be accepted by users to function effectively. At different ages and from different views, several models have been proposed and used to show factors affecting users' IT acceptance. However, such models are in need of frequent revision and development due to variable conditions.

Aim: The present research aims to design a new health IT acceptance model from Iranian users' views. The research aims both to design a model for status quo by reviewing previous models and consider features of Iranian users. **Methods:** This is a correlative, cross-sectional study. Firstly, the primary model was presented by studying important IT acceptance models. Then, a structured questionnaire was designed and, after confirmation of validity and reliability of the questionnaire, it was given to users of information and health IT systems in different wards of hospitals in Iran. Data were analyzed by SPSS and Lisrel and the final model was designed by structural equations. **Results:** The model showed that there are six key factors which are effective on attitude and use intention including performance expectancy, observability, effort expectancy, facilitating conditions, empowerment and subjective norms via three interface factors of perceived usefulness, perceived ease of use, self-efficacy. The size of technology use is an important factor in technology acceptance and application as well. **Conclusion:** The present model has more details compared to the other models and can show a new image of important factors in technology acceptance and their relationships.

Keywords: Health Information Technology, Medical Informatics, Iran, Users.

1. INTRODUCTION

In recent decades, advancement and development of IT and communications have increased the competition between organizations making access to IT the main factor of survival in this competition. Experts believe that there are more fundamental changes that can convert contemporary age to the most basic transient period in human history. Estimates indicate that, since early 1980s, nearly half of investments have been done on IT in organizations. Therefore, IT is known as a powerful factor in socio-economic changes (1). Studies show that IT is among the important factors affecting organizational performance and it plays an important role in performance evaluation (2), redesign of processes (3), sale dimensions, cost reductions and return on asset (4).

However, technology acceptance by users is more important than application of new technologies. Many internal and external factors are effective on technology acceptance. Among external factors are lack of sufficient standards for application of IT (5) and certain supportive rules and regulations (6). High cost of IT application and difficulty in measuring investment return, lack of technical skills and staff and employees' knowledge of IT are among internal factors. In addition, the role of human and cultural factors is very important. Reports indicate that 80-90% of IT projects do not reach their performance targets because organizations do not pay attention to non-technical factors such as human, organizational and cultural factors when using technology whereas these factors have determinant roles in effectiveness

© 2019 Mehrdad Farzandipour, Somayyeh Nadi Ravandi, Hamidreza Gilasi, Nabiallah Soleimani

This is an Open Access article distributed under the terms of the Creative Commons Attribution Non-Commercial License (<http://creativecommons.org/licenses/by-nc/4.0/>) which permits unrestricted non-commercial use, distribution, and reproduction in any medium, provided the original work is properly cited.

Features	Theories												
	AM	TAM ₂	IDT	TPB	TRA	UTAUT	TIB	TAM+TPB	TRUST	TAM+TPB+	IDT	TAM+TPB+	TAM+IDT+TIB
Perceived usefulness	✓	✓	--	--	--	--	--	✓	✓	✓	✓	✓	✓
Perceived Ease of Use	✓	✓	--	--	--	--	--	✓	✓	✓	✓	✓	✓
Attitude	✓	✓	--	✓	✓	--	--	✓	✓	--	--	✓	✓
Use behavior	✓	✓	--	✓	✓	--	--	--	--	--	--	--	--
Perceived usefulness	--	✓	--	✓	✓	✓	✓	--	✓	--	--	✓	✓
Perceived behavioral control	--	--	--	✓	--	--	--	✓	✓	✓	✓	✓	--
Behavioral intention	✓	✓	--	✓	✓	--	✓	✓	✓	✓	✓	✓	✓
Relative advantage of innovation	--	--	✓	--	--	--	--	--	--	--	--	--	--
Compatibility	--	--	✓	--	--	--	--	--	--	--	--	--	✓
Complexity	--	--	✓	--	--	--	--	--	--	--	--	--	--
Observability	--	--	✓	--	--	--	--	--	--	--	--	--	--
Performance expectancy	--	--	--	--	--	✓	--	--	--	--	--	--	--
Effort expectance	--	--	--	--	--	✓	--	--	--	--	--	--	--
Facilitating conditions	--	--	--	--	--	✓	✓	--	--	--	--	--	✓
Perceived behavioral outcomes	--	--	--	--	--	--	✓	--	--	--	--	--	--
Habit	--	--	--	--	--	--	✓	--	--	--	--	--	--
Trust	--	--	--	--	--	--	--	--	✓	--	--	--	--
Innovation in IT	--	--	--	--	--	--	--	--	--	--	✓	--	--
Image	--	--	--	--	--	--	--	--	--	--	✓	--	--
Results demonstrability	--	--	--	--	--	--	--	--	--	--	✓	--	--
Experience	--	✓	--	--	--	✓	--	--	--	--	--	--	--

Table 1. Features of IT acceptance theories for preparing a hypothetic model

of new systems (7). It is especially evident in developing and undeveloped countries and it seems that there is a relationship between the concept of electronic preparation and IT acceptance due to low rate of IT acceptance in undeveloped and developing countries (8). Health information technologies are very prevalent in management of chronic diseases, disease prevention and health promotion. In order to use health information effectively, health users have to measure, save and manage their data (9) and health providers should not resist against them. In order to solve these problems, several models have been presented for studying technology acceptance and each has studied this issue from a different viewpoint some of which include innovation diffusion theory (IDT), rational action theory,

planned behavior theory and technology acceptance model. Since users' health IT acceptance is of utmost important, the present study aims to design and test health IT acceptance model from Iranian users' views. In addition to identifying main components of health IT acceptance, this model can increase service quality, efficiency and successful application of the model in organizations.

2. METHODS

2.1. Data collection and population

Statistical population included experts of health IT evaluating the questionnaire. Then, all users of health IT systems in educational hospitals of Iran were used to collect information and to evaluate the primary model.

Items	Performance expectancy	observability	Relative advantage	Facilitating conditions	Effort expectance	empowerment	Subjective norm	Perceived usefulness	perceived ease of use	Self-efficacy	Use size	attitude
Performance expectancy	1											
Observability	.276**	1										
Relative advantage	.227**	.418**	1									
Facilitating conditions	.283**	.303**	.277**	1								
Effort expectance	.225**	.317**	.315**	.346**	1							
Empowerment	.290**	.235**	.312**	.327**	.344**	1						
Subjective norm	.213**	.259**	.240**	.275**	.363**	.291**	1					
Perceived usefulness	.191**	.233**	.331**	.170**	.276**	.241**	.286**	1				
perceived ease of use	.223**	.260**	.287**	.130**	.287**	.209**	.245**	.456**	1			
Self-efficacy	.161**	.209**	.281**	.179**	.249**	.267**	.249**	.368**	.468**	1		
Extent of use	.101*	.133**	.169**	.112*	.201**	.149**	.208**	.380**	.375**	.472**	1	
Attitude	.124*	.122*	.178**	.232**	.188**	.243**	.229**	.220**	.185**	.253**	.218**	1

*P < .05, **P < .01.

Table 2. Correlation coefficients between measured variables

Stratified random sampling was used to generalize results to the statistical population. Seven classes of users of health IT systems were chosen including personnel of medical documents, radiology, pharmacy, laboratory, nurses, IT personnel, and financial affairs and discharge. Sample size was determined using Cochran formula (1) (400 persons). 60 individuals were placed in each seven class. In general, 420 respondents answered the questionnaires.

$$n = \frac{z^2 pq}{d^2} \quad Z=1.96, p=.57, q=.43, d= .05$$

Where, n is the sample size, z is the selected critical value of desired confidence level, p is the estimated proportion of an attribute that is present in the population, p= 1-q and d is the desired level of precision.

In order to collect the data, questionnaires were given to participants. Written informed consent forms were signed by all participants of the study and they freely expressed their willingness to participate in the study. Prior to conducting the research, the study was approved by the Ethical committee of Kashan university of medical sciences with approval No: IR.KAUMS.REC.1394.85.

2.2. Research instrument

A hypothetical model was prepared based on previous studies conducted in the same area, field studies, and theories such as TAM, TBP, IDT, TAM2, UTAUT, TRA, and TIB. Table 1 shows features of different theories of IT acceptance that were used in the model.

The hypothetical model (Figure 1) was based on re-

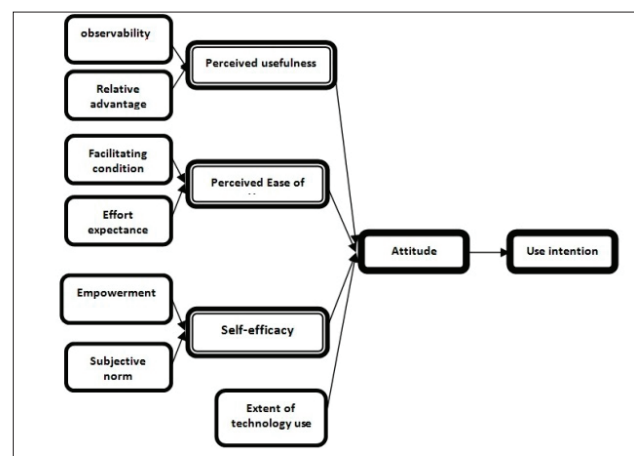

Figure 1. Hypothetical model

search aims and included some variables of other models. Nevertheless, some variables of the model have been displaced compared to other models. For example, in TAM model, perceived usefulness associates with Perceived Ease of Use while in the present hypothetical model, these two do not show direct relationship. Thus, perceived usefulness was affected by performance expectancy, observability and relative advantages. Perceived usefulness was also affected by facilitating conditions and effort expectancy

A structured questionnaire was designed based on the hypothetical model. The initial questionnaire consisted of 15 areas including performance expectancy, (5 items), observability (4 items), relative advantage (4 items), facilitating conditions (5 items), effort ex-

Features	N	Min.	Max.	Mean	Std. Deviation	Skewness	Kurtosis	Cronbach alpha	No. of items			
	Statistic	Statistic	Statistic	Statistic	Std. Error	Statistic	Statistic					
Performance expectancy	399	2	10	3.3358	0.07022	1.40262	1.144	0.122	1.584	0.244	0.558	2
Observability	400	2	7	3.475	0.06361	1.27217	0.588	0.122	-0.253	0.243	0.296	2
Relative advantage	400	3	14	5.435	0.0913	1.82595	0.596	0.122	0.551	0.243	0.435	3
Facilitating conditions	400	4	13	6.5725	0.10916	2.18327	0.684	0.122	-0.257	0.243	0.545	4
Effort expectance	400	3	14	5.24	0.09535	1.90696	0.804	0.122	0.749	0.243	0.549	3
empowerment	399	3	13	5.1704	0.0933	1.8637	0.752	0.122	0.424	0.244	0.58	3
Subjective norm	400	3	12	5.3925	0.0933	1.86605	0.69	0.122	0.153	0.243	0.508	3
Perceived usefulness	398	7	27	13.211	0.22224	4.43375	0.681	0.122	-0.137	0.244	0.712	7
Perceived ease of use	399	7	27	13.085	0.20813	4.15742	0.487	0.122	-0.237	0.244	0.636	7
Self-efficacy	400	4	17	7.58	0.13904	2.78082	0.734	0.122	0.135	0.243	0.555	4
Extent of Use	400	3	13	5.805	0.11817	2.36346	0.743	0.122	-0.186	0.243	0.554	3
Attitude	399	4	17	7.7343	0.13886	2.77364	0.702	0.122	0.325	0.244	0.58	4

Table 3. Descriptive statistics of the latent variables and the reliability coefficients

pectancy (9 items), empowerment (3 items), subjective norms (4 items), perceived usefulness (22 items), perceived ease of use (14 items), self-efficacy (7 items), extent of technology use (4 items), attitude (4 items) and use intention (4 items).

2.3. Validity and Reliability

Face validity of the questionnaire was measured based on the opinions of three expert faculty members in department of health information management and health IT. In the present study, content validity index and content validity ratio were used to confirm content validity. Firstly, the initial questionnaire was corrected twice by Delphi method and submitted to ten experts of health information management and health IT. Experts were asked to assess validity based on three scales: 'it is necessary', 'it is proper, not necessary' and 'it is not necessary'. CVR was calculated in the first stage after receiving the opinions. Questions with validity percentage below 62% were deleted from the questionnaire. Regarding other variables, three questions of performance expectancy, two questions of observability, one question of facilitating conditions, 6 questions of effort expectancy, one question of subjective norm, 15 questions of perceived usefulness, 7 questions of perceived ease of use, 3 questions of self-efficacy and one question of the extent of IT use were deleted. All questions of variables of attitude, use intention, empowerment and relative advantage were confirmed. In the second stage, the questionnaire was

given to the same experts in order to confirm validity index and validity index. Evaluation showed that all questions were confirmed. In order to calculate content validity index (CVI), simplicity, relation and transparency were evaluated in questionnaire through Likert's four-point scale. As a result, validity of the questionnaire was confirmed. Then, the questionnaire was given to 50 users in statistical population. After data collection and analysis, reliability of questionnaire was obtained as 0.842 via Cronbach's alpha. Correlation coefficients of variables can be seen in Table 2.

2.4 Statistical analysis

SPSS was used to analyze quantitative variables and data. Moreover, LISREL was used to present the model of structural equations and the final model.

3. RESULTS

Participants included 400 individuals from different fields of IT in educational hospitals of Iran. Most participants were females with B.S degrees and they were over 30 years old. They had work experience of between 5 and 10 years. Descriptive statistics of variables' scores and reliability coefficients of the questionnaire are shown in Table 3.

Exploratory factor analysis and LISREL were used to determine the effect of factors (such as perceived usefulness, perceived ease of use, self-efficacy and the size of technology) on attitude. Exploratory factor analysis was used to reach the highest correlation amount be-

Kaiser-Meyer-Olkin Measure of Sampling Adequacy.	.827
Bartlett's Test of Sphericity	Approx. Chi-Square
	Df
	Sig.
	3.312E3
	903
	.000

Table 4. Bartlett's and KMO tests

Component	Initial Eigenvalues			Extraction Sums of Squared Loadings		
	Total	% of Variance	Cumulative %	Total	% of Variance	Cumulative %
Performance expectancy	6.69	15.558	15.558	6.69	15.558	15.558
Observability	2.486	5.782	21.339	2.486	5.782	21.339
Relative advantage	1.798	4.182	25.521	1.798	4.182	25.521
Facilitating condition	1.632	3.796	29.317	1.632	3.796	29.317
Effort expectancy	1.495	3.477	32.794	1.495	3.477	32.794
Empowerment	1.407	3.272	36.066	1.407	3.272	36.066
Subjective norm	1.323	3.076	39.142	1.323	3.076	39.142
Perceived usefulness	1.31	3.046	42.187	1.31	3.046	42.187
Perceived ease of use	1.244	2.893	45.081	1.244	2.893	45.081
Self-efficacy	1.205	2.803	47.884	1.205	2.803	47.884
Size of technology use	1.102	2.564	50.448	1.102	2.564	50.448
Attitude	1.061	2.468	52.916	1.061	2.468	52.916
Use intention	1.029	2.393	55.309	1.029	2.393	55.309

Table 5. Eigenvalues of variances for each factor and cumulative variance

tween variables and the results were shown in Table 4.

The value of Kaiser-Meyer-Olkin measure of sampling adequacy was equal to 0.827. Also, Bartlett's test was significant. Since p-value was less than 0.05, it is concluded that correlation matrix between variables is not an identity matrix, meaning that there is correlation between variables.

In table 5, the first three columns on the left side are eigenvalues of factors whose eigenvalues are equal to 1 and they remain in the analysis. Factors with eigenvalue below one or those explored by one observable variable were excluded from the analysis. The first three columns on the right side show eigenvalues of extracted factors with varimax rotation and corresponding variance with factors. These 13 factors can explore 0.55 of main construct variance in health IT acceptance model from Iranian users' views. It is noteworthy that in social science research, cumulative frequency of variance percentage related to eigenvalues is not acceptable to be below 0.50. Therefore, items classified were into 13 factors and 42 items using exploratory factor analysis in order to study and present health IT acceptance model from the viewpoint of Iranian users. Items with factor load below 0.4 were deleted.

Exploratory factor analysis and SPSS were used to study independent variables for each factor and to delete independent variables whose correlation was below 0.4. Independent variables under one factor can

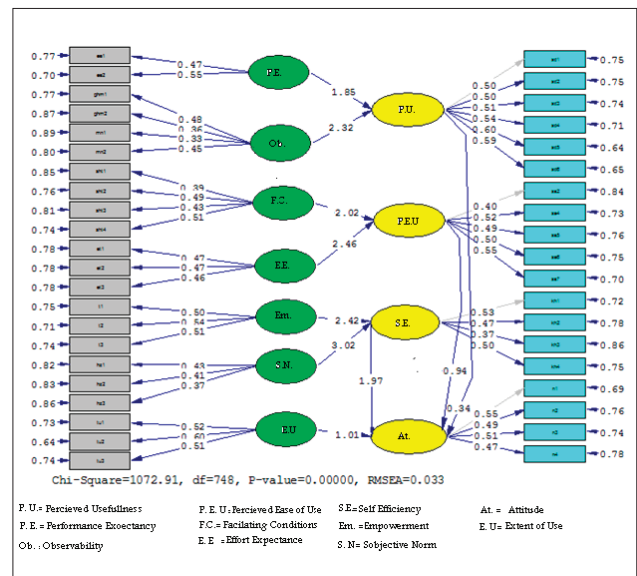

Graph 1. Estimation of final model parameters of structural equations in standard estimation

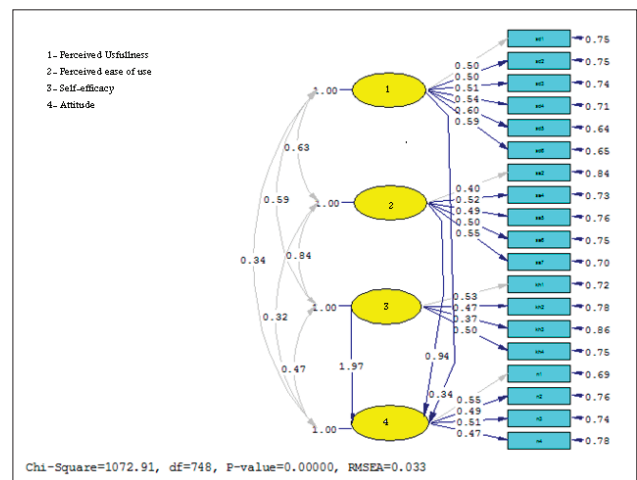

Graph 2. Structural section of the final model of structural equations in standard estimation based on latent variable

be combined. Results obtained by exploratory factor analysis suggest that the initial model which was a reasonable model based on the opinions and studies of experts was changed into a proper model by deletion of three variables of observability and conversion of three factors into two factors under the variable "perceived usefulness". In other words, the initial model was converted into a mathematical one. Then, the mathematical model was fitted with data in order to see whether it was fitted on data. Thus, they structural equations were used. In order to fit path analysis model, features of the model were identified such as types of variables in path analysis, arrangement of paths, and parameters that require evaluation. Then, model parameters were fitted and estimated using maximum likelihood. Amount of χ^2 statistic value in the final model was 1072.91 and degree of freedom was 748. The ratio of χ^2 statistics to degree of freedom was 2.61 and they were good reasons for proper fitness and evaluation of efficiency of the final model. Also, the value obtained from root mean square of error approximation was 0.033. The obtained result of this value was even lower than 0.1, which was

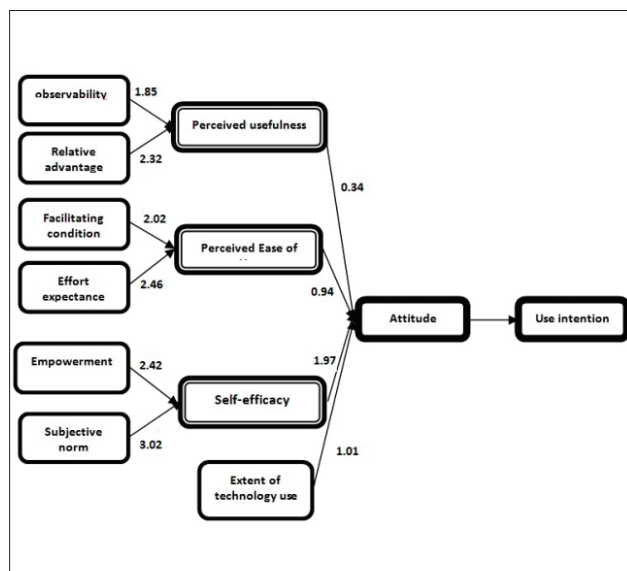

Figure 2: research model

another reason for good fitness of the model. The fitted model in Graphs 1 and 2 was based on observable and latent variables as the main results of the research. Thus, all claims and questions can be studied and measured on this basis. According to the results extracted from path analysis of structural equations with a 95% reliability coefficient (regarding main results), it can be said that there is a significant relationship between perceived usefulness, performance expectancy, observability, perceived ease of use, facilitating conditions, effort expectancy, self-efficacy, empowerment, subjective norm of technology use and attitude.

Results of structural section of the model showed that self-efficacy, use size, perceived usefulness and perceived ease of use were of significant value in attitudes towards users' IT acceptance. Therefore, users' IT acceptance was affected by self-efficacy, use size, perceived ease of use and perceived usefulness.

4. DISCUSSION

At first, factors which were effective on IT acceptance were classified and the primary model was created by making relationships between factors based on previous studies. The initial questionnaire was designed based on the model and, after confirmation of validity and reliability, it was given to users of different wards of governmental hospitals. The final model was designed after data analysis. The final model included 6 key factors: a) performance expectancy, b) observability/relative advantage, c) effort expectancy, d) facilitating conditions, e) empowerment and f) subjective norm. Each two factors follow one intermediate factor in order to reach attitude and use intention. Intermediate factors were used for the first two factors of perceived usefulness, the third and fourth factors of perceived ease of use and the fifth and sixth factors of self-efficacy. There was another factor equivalent with intermediate factors resulting in attitude with three intermediate factors. This factor was size of technology use. Then, IHITAM model was presented.

Generally, based on obtained results, perceived usefulness had a significant effect on users' decisions on technology acceptance. Wu et al (10) showed that perceived usefulness had considerable effect on use intention of healthcare specialists on technology acceptance. Lagris et al (11) believed that subjective interpretation from perceived usefulness in clinical information systems was an important factor for explanation and prediction of users' use intention of information systems. SheikhShoaei and Oloomi (12) showed in their study that mental interpretation from perceived usefulness had the most indirect effect on technology acceptance. Another result of this study was that there is significant effect of self-efficacy on users' decisions regarding IT acceptance. Mooghali et al (13) showed that self-efficacy was one of the factors related to attitude of students towards IT and communications. Moreover, results of another study conducted by Monzavi and Zareie (14) indicated that personality factors had the highest effect among four factors under study and self-efficacy had the highest effect on users' belief in use of new systems. Hsiao et al. (15) found similar results among nurses (significant effect of self-efficacy on hospital information system acceptance). This is consistent with the results of a study conducted by Aggelidis and Chatzoglou (16), which showed that self-efficacy was one of the factors affecting personnel decisions on use of hospital information systems.

The effect of mental interpretation from perceived ease of use on IT acceptance was confirmed in the present research, as was the case in many other studies. In a study conducted by Khorasani et al (17), the relationship between mental interpretation from ease of use and technology acceptance was proved. Results of a study conducted by Aggelidis and Chatzoglou (16) indicated that perceived ease of use had considerable effects on behavior of hospital users concerning IT acceptance. In addition, results of a study conducted by Wilkins (18) revealed that perceived ease of use was one of the three factors affecting health electronic file acceptance by health information managers. As a result, when comparing this model with other models and initial key factors, this model is similar to UTAUT model, which was a unified theory of acceptance and use of technology. UTAUT model is based on the integration of 8 models of IT acceptance and is similar to the present model regarding four key factors of performance expectancy, effort expectancy, facilitating condition and subjective norms. Another similarity between these two models is that they obtained their data from organizational users or service providers (19). But unlike the present model, such key factors led to use intention without intermediate factors (20) and attitude was deleted as was the case in TAM2 model. As seen in TAM2 model, the reason may be that perception of usefulness and perception of ease of technology use, as behavioral beliefs in the primary technology acceptance model, lead to positive or negative attitudes in individual.

Therefore, in secondary technology acceptance model in which both factors are available and neces-

sary for attitude, there was no separate variable such as attitude (19). When comparing IHITAM with TAM, it can be said that the model of the present research has more details than TAM model. In TAM model, it was only stated that external variables were effective on perceived usefulness and perceived ease of use such as education, gender, training and support (20) while in the present model, four key factors had direct effects on two intermediate factors. Performance expectancy and observability/relative advantage were effective on perceived usefulness. Furthermore, facilitating conditions and effort expectancy were effective on perceived ease of use. However, the effect of external factors on user's technology acceptance are not to be ignored whereas the present model indicated that subjective norm and empowerment of users were very effective on users' attitude and technology use. Factor of empowerment in technology use in IHITAM model can be associated with education, training and support in TAM model, which were external variables. When comparing newer IHITAMs such as TAM+TPB, similarities to TAM model are seen except that, unlike IHITAM model, external variables were not directly considered and perceived usefulness and perceived ease of use were directly effective on attitude and use intention.

Also, subjective norms were effective on behavioral intention without intermediate factors (unlike the present model) (21). Kim and Park (22) presented HITAM model that consisted of three main areas of health, information and technology. Health area included behavioral beliefs and interfaces which were effective on attitude and behavior. Information area included subjective beliefs and technology area included productivity, both of which were effective on attitude and behavior. The reason why differences between this model and IHITAM model were observed seems to be type of users based on whose opinions the model was designed. Health service providers believe that the model of the present research is a model designed in health-treatment centers such as hospitals while, from the views of healthcare users, HITAM model was designed online. However, different types of users, culture and even type of population under study can be effective on the final model. The considerable difference between IHITAM model and other models is the factor of 'size of technology use'. This is completely adapted to users' features in Iran and developing countries. Learning technology use is very important concerning software and hardware limitations.

Meta-analysis of factors affecting IT acceptance in Iran indicates that 'size of technology use' is the second factor (after staff empowerment) which is the most effective on IT acceptance in Iranian organizations. Its effect is even higher than 'perceived ease of use' and 'perceived usefulness' factors (19). It seems that the difference between these two models can be due to model origin, visual angle in design of model, type of users, cultural, psychological, and technological differences in communities, etc.

Since technology advancements rapidly influence

health section, a clear image from factors that accelerate technology acceptance and use in work settings might be advantageous. The model of the present research can show such a clear image. The present research presents a new health IT acceptance model. However, all models could be incomplete. It is necessary to revise available models and to design models based on new conditions to achieve more advantages.

- **Acknowledgments:** The authors would like to acknowledge deputy of research, Kashan University of Medical Sciences for supporting this research as a research plan (9485).
- **Author's contribution:** M.F., S.N.R., H.G. and N.S. gave a substantial contribution to the conception and design of the work. N.S. gave a substantial contribution of data. All authors gave a substantial contribution to the acquisition, analysis, or interpretation of data for the work. M.F., S.N.R. had a part in article preparing for drafting or revising it critically for important intellectual content. All authors gave final approval of the version to be published and agreed to be accountable for all aspects of the work in ensuring that questions related to the accuracy or integrity of any part of the work are appropriately investigated and resolved.
- **Conflict of interest:** There are no conflict of interest.
- **Financial support:** Nil

REFERENCES

1. Westland JC, Clark TH. Global electronic commerce theory and case studies: Universities Press; 2001.
2. Brown DH, Lockett N. Potential of critical e-applications for engaging SMEs in e-business: a provider perspective. *Eur J Inf Syst.* 2004 Dec; 13(1): 21-34. doi: 10.1057/palgrave.ejis.3000480
3. Anderson RC, Reeb DM. Board composition: Balancing family influence in S&P 500 firms. *Adm Sci Q.* 2004 Jun; 49(2): 209-237. doi: 10.2307/4131472
4. Zhu K. The complementarity of information technology infrastructure and e-commerce capability: A resource-based assessment of their business value. *JMIS.* 2004 Dec; 21(1): 167-202. doi: 10.1080/07421222.2004.11045794
5. Tuunainen VK. Opportunities of effective integration of EDI for small businesses in the automotive industry. *Inform Manage-Amster.* 1998 Dec; 34(6): 361-375. doi: 10.1016/S0378-7206(98)00070-6
6. Walczuch R, Van Braven G, Lundgren H. Internet adoption barriers for small firms in the Netherlands. *EMJ.* 2000 Oct; 18(5): 561-572. doi: 10.1016/S0263-2373(00)00045-1
7. Cabrera Á, Cabrera EF, Barajas S. The key role of organizational culture in a multi-system view of technology-driven change. *IJIM.* 2001 Jun; 21(3): 245-261. doi: 10.1016/S0268-4012(01)00013-5
8. Straub D, Loch K, Evaristo R, Karahanna E, Srite M. Toward a theory-based measurement of culture. *(JGIM).* 2002 Jan; 10(1): 61-65. doi: 10.4018/jgim.2002010102.
9. Kim J, Park HA. Development of a health information technology acceptance model using consumers' health behavior intention. *J Med Internet Res.* 2012 Oct 1; 14(5): e133. doi: 10.2196/jmir.2143.
10. Wu JH, Shen WS, Lin LM, Greenes RA, Bates DW. Testing the technology acceptance model for evaluating healthcare professionals' intention to use an adverse event reporting system. *Int J Qual Health Care.* 2008 Apr; 20(2): 123-129. doi: 10.1093/intqhc/mzm074.

11. Legris P, Ingham J, Colletette P. Why do people use information technology? A critical review of the technology acceptance model. *Inform Manag.* 2003 Jan; 40(3): 191-204. doi:10.1016/S0378-7206(01)00143-4
12. Sheikh Shoaie F, Olumi T. Effective factors on acceptance of information technology librarians of libraries of engineering colleges in public universities of Tehran. *JLIS.* 2006 Autumn; 9(9-34).
13. Mooghali A, Talebi S, Seif MH. Contributing factors to the attitudes toward using information and communication technology (ICT) among students of Shiraz University of Medical Sciences, School of Management. *Strides Dev Med Educ.* 2011; 8(1): 33-40.
14. Monzavi T, Zarei B. Designing a Model to Explicate Factors Influence the Process of IT User Adoption: (A Research about Iranian Offshore Engineering and Construction Company). *JITM* 2010; 2(5).
15. Hsiao JL, Chang HC, Chen RF. A study of factors affecting acceptance of hospital information systems: a nursing perspective. *Int J Nurs Res.* 2011 Jun; 19(2): 150-160. doi: 10.1097/JNR.0b013e31821cbb25.
16. Aggelidis VP, Chatzoglou PD. Using a modified technology acceptance model in hospitals. *International journal of medical informatics.* 2009; 78(2): 115-126. *Int J Med Inform.* 2009 Feb; 78(2): 115-126. doi: 10.1016/j.ijmedinf.2008.06.006.
17. Khorasani A, Abdolmaleki J, Zahedi H. Factors affecting E-Learning acceptance among students of tehran university of medical sciences based on technology acceptance model (TAM). *IJME.* 2012; 11(6): 664-673. Available on http://ijme.mui.ac.ir/browse.php?a_code=A-10-938-2&slc_lang=en&sid=1&sw=-student
18. Wilkins MA. Factors influencing acceptance of electronic health records in hospitals. *Perspectives in Health Information Management/AHIMA, American Health Information Management Association. Perspect Health Inf Manag.* 2009; 6(Fall): 1f. PMID: 20169018
19. Ghorbanizadeh V, Nangeer SH, Roodsaz SH. Meta-analysis of Effecting Factors on the Information Technology Acceptance in Iran. *Journal of Management Studies in Iran,* 2013 Dec; 17(2): 177-196 doi: 10.17718/tojde.471649
20. Venkatesh V, Morris MG, Davis GB, Davis FD. User acceptance of information technology: Toward a unified view. *MIS QUART.* 2003 Sep; 425-478. doi: 10.2307/30036540
21. Wu L, Chen JL. An extension of trust and TAM model with TPB in the initial adoption of on-line tax: an empirical study. *Int J Hum-Comput St.* 2005 Jun; 62(6): 784-808. doi: 10.1016/j.ijhcs.2005.03.003.