

Cannula Size Effect on Stromal Vascular Fraction Content of Fat Grafts

Hilton Becker, MD*†
Oscar Adrian Vazquez, MS*
Tans Rosen†

Background: Fat is an active and dynamic tissue composed of adipocytes supported by a structural framework known as the stromal vascular fraction (SVF). SVF is traditionally isolated by enzymatic processing, but new methods are being investigated to isolate it mechanically. Recent studies propose that fat harvested with larger cannulas has a higher survival rate, most likely due to a higher concentration of SVF.

Methods: Lipoaspirates were obtained from 10 patients who underwent elective liposuction using a 5-mm and a 1-mm cannula attached to a syringe using standard pressure. The fat was aspirated from the same area at adjacent sites. An estimated 5-mm fat particles were also cut down to 1-mm using a micronizer (Marina Medical). A 5-cm³ volume of each sample was compressed through a 0.5-mm opening strainer and rinsed with normal saline to extrude the oil. The resultant SVF left on the strainer was then measured in a 1-cm³ syringe.

Results: The volume extracted from a 5-mm cannula (mean, 0.23 cm³; SD, 0.10) versus a 1-mm cannula (mean, 0.11 cm³; SD, 0.06) was statistically significant ($P = 0.009$). An H&E-stained slide from the SVF was obtained for confirmation. Finally, 5-mm fat particles cut down to 1-mm particles using the micronizer resulted in an average volume of 0.20 cm³, which was higher than the average volume harvested with a 1-mm cannula.

Conclusions: Harvesting with a 5-mm cannula resulted in significantly more SVF than harvesting with a 1-mm cannula. Resizing fat particles harvested with a larger cannula down to 1-mm resulted in higher SVF than SVF obtained with a 1-mm cannula directly. (*Plast Reconstr Surg Glob Open* 2021;9:e3471; doi: 10.1097/GOX.0000000000003471; Published online 23 March 2021.)

INTRODUCTION

Liposuction aspirates obtained from lipectomy procedures are a rich source of adipose-derived stem cells (ADSCs), a cell population of recent interest for its regenerative potential. Since the time they were first characterized by Zuk et al in 2001, ADSCs have been extensively studied for their multipotency, paracrine effects, and implications for regenerative medicine.¹ However, several studies have suggested that the regenerative properties of lipoaspirate are found not only in the ADSCs, but also in the mixed cell population of the lipoaspirate they are derived from, the stromal vascular fraction (SVF).²⁻⁹ This regenerative mix, which is traditionally isolated by

enzymatic processing, contains multiple cell populations, including mesenchymal stem cells, endothelial progenitor cells (EPCs), immune cells, smooth muscle cells, pericytes, and other stromal components like fibroblasts.² Although its cellular proportions may vary significantly based on processing and protocol, SVF has the regenerative potential to be used in therapies for numerous diseases such as multiple sclerosis and diabetes.^{10,11}

Some studies have shown that fat harvested with larger cannulas has a higher survival rate.¹² Although this is contrary to prior reports of better graft survival with smaller particle size, the survival of larger particles may be due to the fact that they are subjected to less trauma, and that they have a higher SVF content.¹³ This study was therefore undertaken to measure the SVF content in fat harvested with a 5-mm cannula compared with a 1-mm cannula. It has been documented that particles of fat smaller than 1-mm have a better survival; therefore, the fat harvested with a 5-mm cannula was also cut into 1-mm particle size to see if the SVF concentration was affected. Finally, a sample of the SVF was stained with hematoxylin and eosin (H&E) for identification.

From the *Charles E. Schmidt College of Medicine, Florida Atlantic University, Boca Raton, Fla.; and †Clinic of Plastic Surgery, Boca Raton, Fla.

Received for publication November 13, 2020; accepted January 7, 2021.

Copyright © 2021 The Authors. Published by Wolters Kluwer Health, Inc. on behalf of The American Society of Plastic Surgeons. This is an open-access article distributed under the terms of the [Creative Commons Attribution-Non Commercial-No Derivatives License 4.0 \(CCBY-NC-ND\)](https://creativecommons.org/licenses/by-nc-nd/4.0/), where it is permissible to download and share the work provided it is properly cited. The work cannot be changed in any way or used commercially without permission from the journal.

DOI: 10.1097/GOX.0000000000003471

Disclosure: Dr. Becker is a consultant for Marina Medical. The other authors have no financial interest to declare in relation to the content of this article. No funding was received for this article.

METHOD

General Information (Patient Demographics and Consent)

Informed consent was obtained from 10 healthy female patients who underwent elective liposuction of areas such as the thighs, flanks, or abdomen for the unused fat meant to be discarded to be subjected to mechanical manipulation after the procedure. Ages ranged from 18 to 77 years (average age: 53.7 years). The ethical principles stated in the 2013 Declaration of Helsinki were strictly followed.

Adipose Tissue Harvesting

Lipoaspirate was obtained from 10 healthy patients at the same area, but adjacent sites (eg, upper versus lower thigh, left versus right periumbilical region) and all liposuctions were performed by the same surgeon. In preparation for harvesting lipoaspirate, a 0.9% (weight/volume) solution of sodium chloride containing epinephrine at a concentration of 1:100,000 and lidocaine at a concentration of 1:1000 (Klein's solution) was infiltrated by means of a 2.5-mm injection cannula and left to stand for approximately 20 minutes. The volume was equal to the volume of fat tissue harvested. The lipoaspirate was harvested using custom-made cannulas with internal diameters and single opening diameters of 1-mm and 5-mm (Marina Medical, Davie, Fla.) under standard pressure with a 20 cm³ syringe [approximately -600 mm Hg (-0.789 atm)¹⁴]. Lipoaspirates were left to stand for 10 minutes to decant, the supernatant fluid was extracted, and the fat was then placed in 5-cm³ syringes for volume control.

SVF Harvesting

The fat was then compressed through a strainer with 0.5-mm openings and rinsed with normal saline to extrude the oil while retaining the SVF until a white-colored residual tissue was obtained (Figs. 1, 2). The resultant SVF was then placed in 1-cm³ syringes and the volume measured (Fig. 3). An estimated 5-mm fat particles were also cut down to 1-mm particles using a custom micronizer (Marina Medical, Davie, Fla.) and the SVF measured (Figs. 4, 5).

SVF Characterization

SVF harvested from 5- and 1-mm cannulas was placed on glass slides and fixed to be stained with H&E stain for identification, which was photographed under 20× magnification.

Statistical Analysis

Quantitative variables were summarized with means, medians, and SDs. A ratio of the volume of SVF extracted by the 5 cm³ total volume of fat was calculated and reported as an average. Data were analyzed with a paired sample *t*-test and a *P* < 0.05 denoted a significant difference.

RESULTS

The SVF volume extracted from harvesting with a 1-mm cannula ranged from 0.05 cm³ to 0.25 cm³ with the median being 0.09 cm³ and the average ratio of SVF/5 cm³



Fig. 1. Cannula extract (1-mm) on mesh.



Fig. 2. Cannula extract (5-mm) on mesh.

volume at 0.02. The SVF volume extracted from harvesting with a 5-mm cannula ranged from 0.13 cm³ to 0.40 cm³ with the median being 0.17 cm³ and the average ratio of SVF/5 cm³ volume at 0.05. The SVF volume extracted from a 5-mm cannula (mean, 0.23 cm³; SD, 0.10) versus a 1-mm cannula (mean, 0.11 cm³; SD, 0.06) was statistically significant (*P* = 0.009) (Fig. 6). Additionally, 5-mm fat particles cut down to 1-mm fat particles using the micronizer resulted in an average SVF volume of 0.20 cm³ with an average ratio of SVF/5 cm³ volume of 0.04. H&E-stained slide of SVF showed a dense collagen network with cell nuclei (Fig. 7).

DISCUSSION

The increasing use of autologous lipo-transfer, or fat grafting, in plastic and reconstructive surgery has warranted an exploration of novel ways to improve clinical outcomes.^{15,16} Currently, plastic surgeons are challenged

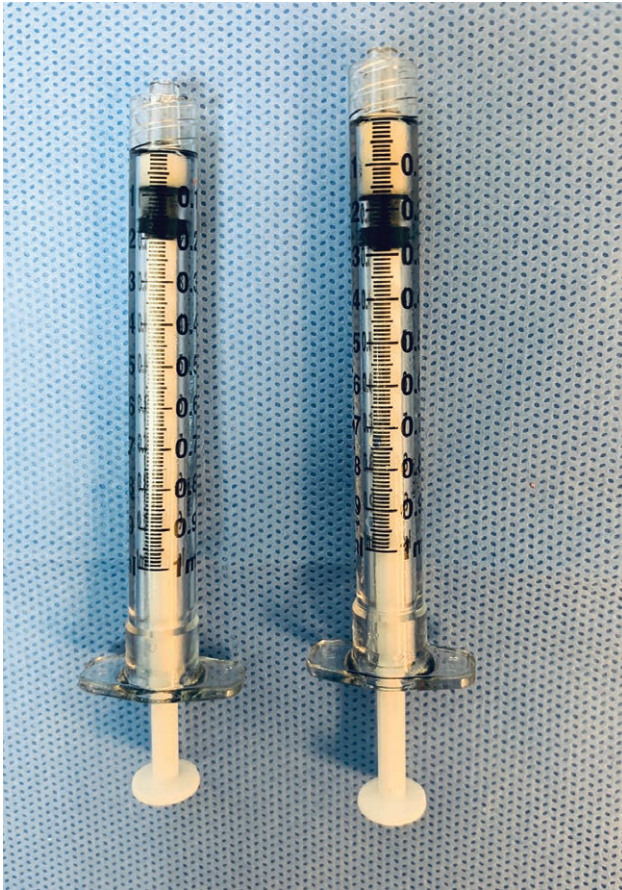

Fig. 3. Comparison between 1-mm and 5-mm extract.

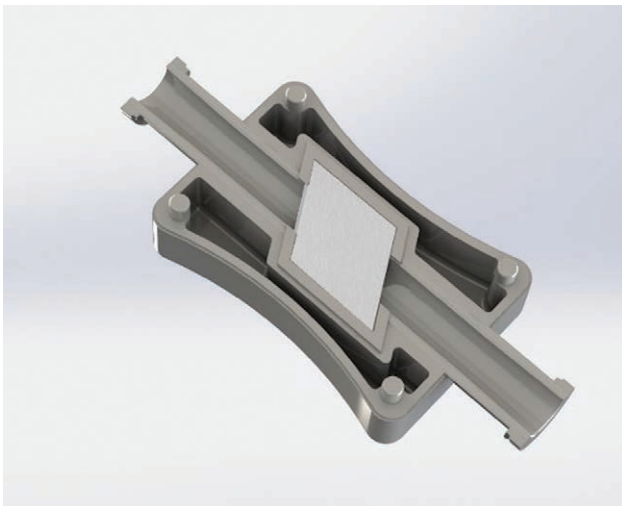

Fig. 4. Micronizer.

by a significant variability in fat graft retention since reported resorption rates range from 25% to 80%.¹⁷ Much of the volume loss is believed to be due to the tendency of mature adipocytes to undergo cell death after injection into the recipient site.¹⁸ Fat cell survival appears to be dependent upon its location within the graft: peripherally,

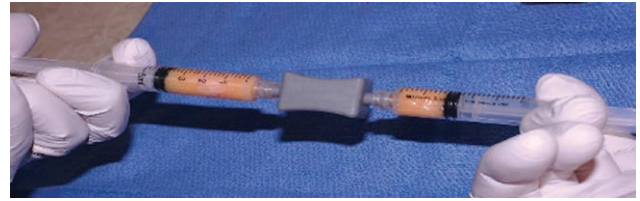

Fig. 5. Micronizer cutting 5-mm particles into 1-mm particles.

adipocytes often survive, but centrally, they necrose. The peripheral zone of the graft is the area of regeneration, where ADSCs stimulate the replacement and survival of adipocytes.¹⁸ Centrally, cell death occurs most prominently as a result of ischemia and poor tissue oxygenation.¹⁷⁻¹⁹

SVF cells and adipose stem cells have recently gained significant attention because of their increased angiogenic and wound-healing capacity from the regenerative paracrine effects of vascular endothelial growth factor (VEGF), hepatocyte growth factor, and transforming growth factor. Whether supplementing lipoaspirates with SVF cells or adipose stem cells or enriching these cells through centrifugation, both of these methods have yielded larger fat grafts and longer retention of these grafts.^{17,20-24} Gentile et al demonstrated that patients treated with SVF-enhanced autologous fat grafts maintained 63% of the fat graft volume after 1 year compared with the 39% maintained in the control group.^{22,23} Comparable results have been achieved with adipose stem cell supplementation. Kølbe et al found that adipose stem cell supplementation of lipoaspirates enhanced the formation of new connective tissue and reduced the amount of necrotic tissue of the fat graft.¹⁷

It has been shown that fat that is directly excised has a higher adipose cell viability, which is postulated to be related to the SVF content. It is also believed that harvesting fat with a larger cannula will resect more SVF.²⁵ Furthermore, a recent study by Sesè et al analyzed H&E histology of SVF (termed “stromal cell aggregates”), which showed a network of connective tissue where stromal cells are located and further quantified the collagen density.²⁶ This study demonstrated that fat harvested with a 5-mm cannula contains more SVF than fat harvested with a 1-mm cannula, and that the SVF remained constant even when the fat was cut into 1-mm particles. Finally, it was also noted that there was a wide variation in SVF content from patient to patient. Future studies will assess the effect of age, site of harvest, and BMI in SVF content obtained.

CONCLUSIONS

Harvesting fat with a 5-mm cannula yields significantly more SVF than harvesting 1-mm cannulas due to the harvesting of larger fat particles. Cutting down the harvested 5-mm fat particles to 1-mm resulted in an increased amount of SVF extracted as opposed to harvesting directly with a 1-mm cannula. We therefore postulate that harvesting with larger-sized cannulas and then resizing the particles down to 1-mm may result in enhanced fat graft survival.

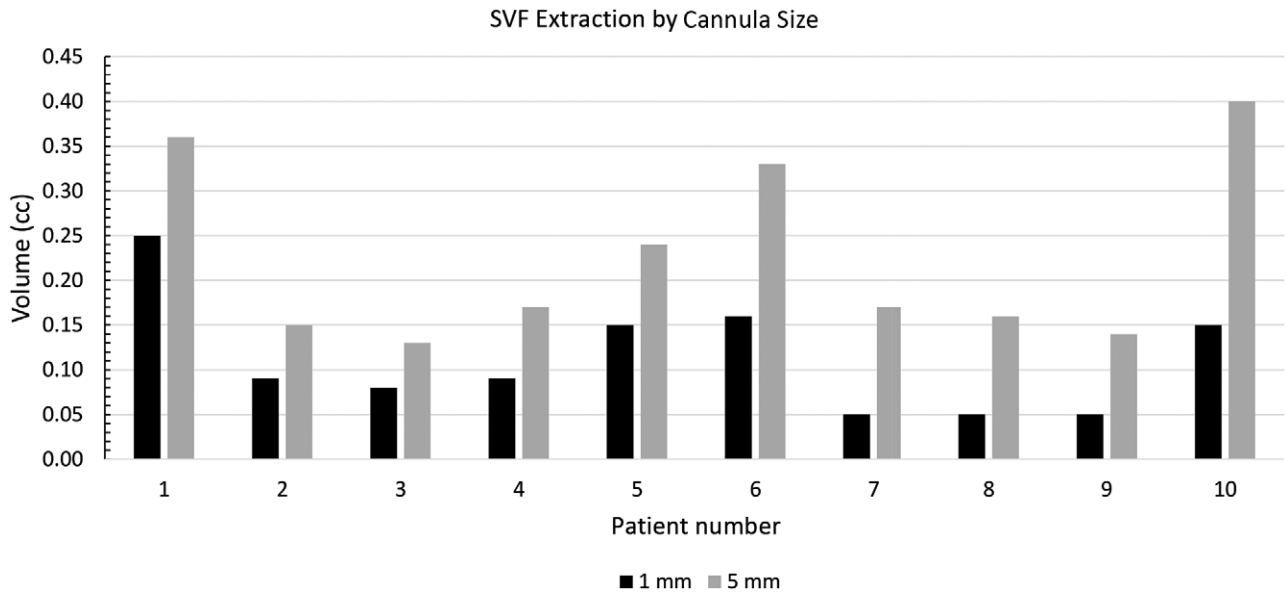

Fig. 6. SVF extracted from different cannula sizes.

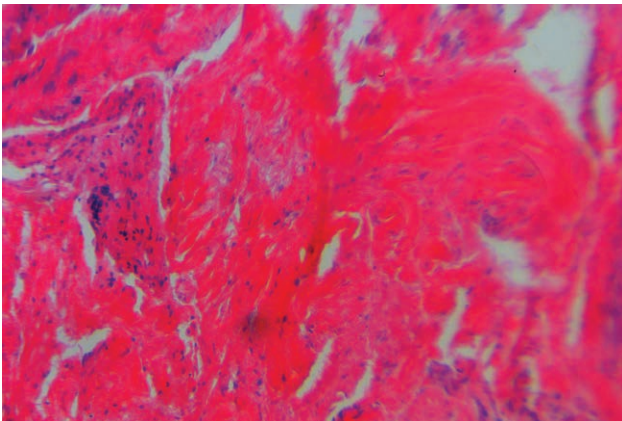

Fig. 7. H&E-stained slide of SVF showing a dense collagen network with cell nuclei.

Hilton Becker, MD

670 Glades Rd, STE 220

Boca Raton, FL 33431

E-mail: hilton@beckerMD.com

REFERENCES

- Zuk PA, Zhu M, Mizuno H, et al. Multilineage cells from human adipose tissue: implications for cell-based therapies. *Tissue Eng.* 2001;7:211–228.
- Riordan NH, Ichim TE, Min WP, et al. Non-expanded adipose stromal vascular fraction cell therapy for multiple sclerosis. *J Transl Med.* 2009;7:29.
- Yoshimura K, Sato K, Aoi N, et al. Cell-assisted lipotransfer for cosmetic breast augmentation: supportive use of adipose-derived stem/stromal cells. *Aesthetic Plast Surg.* 2008;32:48–55.
- Li J, Gao J, Cha P, et al. Supplementing fat grafts with adipose stromal cells for cosmetic facial contouring. *Dermatol Surg.* 2013;39(3 pt 1):449–456.
- van Dijk A, Naaijken BA, Jurgens WJ, et al. Reduction of infarct size by intravenous injection of uncultured adipose derived stromal cells in a rat model is dependent on the time point of application. *Stem Cell Res.* 2011;7:219–229.
- Atalay S, Coruh A, Deniz K. Stromal vascular fraction improves deep partial thickness burn wound healing. *Burns.* 2014;40:1375–1383.
- Rajashekhar G, Ramadan A, Abburi C, et al. Regenerative therapeutic potential of adipose stromal cells in early stage diabetic retinopathy. *PLoS One.* 2014;9:e84671.
- Chung MT, Zimmermann AS, Paik KJ, et al. Isolation of human adipose-derived stromal cells using laser-assisted liposuction and their therapeutic potential in regenerative medicine. *Stem Cells Transl Med.* 2013;2:808–817.
- Premaratne GU, Ma LP, Fujita M, et al. Stromal vascular fraction transplantation as an alternative therapy for ischemic heart failure: anti-inflammatory role. *J Cardiothorac Surg.* 2011;6:43.
- You HJ, Han SK. Cell therapy for wound healing. *J Korean Med Sci.* 2014;29:311–319.
- Jarajapu YP, Grant MB. The promise of cell-based therapies for diabetic complications: challenges and solutions. *Circ Res.* 2010;106:854–869.
- Ozsoy Z, Kul Z, Bilir A. The role of cannula diameter in improved adipocyte viability: a quantitative analysis. *Aesthet Surg J.* 2006;26:287–289.
- Zeltzer AA, Tonnard PL, Verpaale AM. Sharp-needle intradermal fat grafting (SNIF). *Aesthet Surg J.* 2012;32:554–561.
- Rodriguez RL, Condé-Green A. Quantification of negative pressures generated by syringes of different calibers used for liposuction. *Plast Reconstr Surg.* 2012;130:383e–384e.
- Tocco I, Widgerow AD, Lalezari S, et al. Lipotransfer: the potential from bench to bedside. *Ann Plast Surg.* 2014;72:599–609.
- Kakagia D, Pallua N. Autologous fat grafting: in search of the optimal technique. *Surg Innov.* 2014;21:327–336.
- Kølle SF, Fischer-Nielsen A, Mathiasen AB, et al. Enrichment of autologous fat grafts with ex-vivo expanded adipose tissue-derived stem cells for graft survival: a randomised placebo-controlled trial. *Lancet.* 2013;382:1113–1120.
- Eto H, Ishimine H, Kinoshita K, et al. Characterization of human adipose tissue-resident hematopoietic cell populations reveals a novel macrophage subpopulation with CD34 expression and mesenchymal multipotency. *Stem Cells Dev.* 2013;22:985–997.

19. Karacaoglu E, Kizilkaya E, Cermik H, et al. The role of recipient sites in fat-graft survival: experimental study. *Ann Plast Surg.* 2005;55:63–68.
20. Zhu M, Zhou Z, Chen Y, et al. Supplementation of fat grafts with adipose-derived regenerative cells improves long-term graft retention. *Ann Plast Surg.* 2010;64:222–228.
21. Li J, Gao J, Cha P, et al. Supplementing fat grafts with adipose stromal cells for cosmetic facial contouring. *Dermatol Surg.* 2013;39(3 pt 1):449–456.
22. Gentile P, De Angelis B, Pasin M, et al. Adipose-derived stromal vascular fraction cells and platelet-rich plasma: basic and clinical evaluation for cell-based therapies in patients with scars on the face. *J Craniofac Surg.* 2014;25:267–272.
23. Tanikawa DYS, Aguena M, Bueno DF, et al. Fat grafts supplemented with adipose-derived stromal cells in the rehabilitation of patients with craniofacial microsomia. *Plast Reconstr Surg.* 2013;132:141–152.
24. Piccinno MS, Veronesi E, Loschi P, et al. Adipose stromal/stem cells assist fat transplantation reducing necrosis and increasing graft performance. *Apoptosis.* 2013;18:1274–1289.
25. Gause TM II, Kling RE, Sivak WN, et al. Particle size in fat graft retention: A review on the impact of harvesting technique in lipofilling surgical outcomes. *Adipocyte.* 2014;3:273–279.
26. Sesé B, Sanmartín JM, Ortega B, et al. Human stromal cell aggregates concentrate adipose tissue constitutive cell population by in vitro DNA quantification analysis. *Plast Reconstr Surg.* 2020;146:1285–1293.