

Wiener-Neural-Network-Based Modeling and Validation of Generalized Predictive Control on a Laboratory-Scale Batch Reactor

Prajwal Shettigar J, Jatin Kumbhare, Eadala Sarath Yadav, and Thirunavukkarasu Indiran*

Cite This: *ACS Omega* 2022, 7, 16341–16351

Read Online

ACCESS |

Metrics & More

Article Recommendations

ABSTRACT: Batch reactors are large vessels in which chemical reactions take place. They are mostly found to be used in process control industries for processes such as reactant mixing, waste treatment of leather byproducts, and liquid extraction. Modeling and controlling of these systems are complex due to their highly nonlinear nature. The Wiener neural network (WNN) is employed in this work to predict and track the temperature profile of a batch reactor successfully. WNN is different from artificial neural networks in various aspects, mainly its structure. The brief methodology that was deployed to complete this work consisted of two parts. The first part is modeling the WNN-based batch reactor using the provided input–output data set. The input is feed given to the reactor, and the reactor temperature needs to be maintained in line with the optimal profile. The objective in this part is to train the neural network to efficiently track the nonlinear temperature profile that is provided from the data set. The second part is designing a generalized predictive controller (GPC) using the data obtained from modeling the reactor to successfully track any arbitrary temperature profile. Therefore, this work presents the experimental modeling of a batch reactor and validation of a WNN-based GPC for temperature profile tracking.

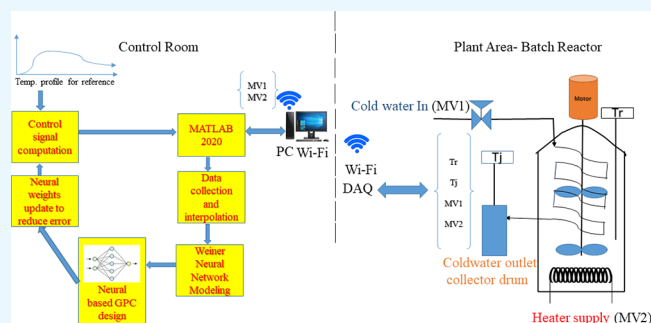

1. INTRODUCTION

Batch reactors are found to be used extensively in process control industries. They are used for various processes such as chemical reactions, product mixing, and liquid extraction. It consists of a storage tank to store the chemical reactants, an agitator to enhance the stirring and mixing of the chemical reactants, and a heating/cooling system to achieve the optimum temperature required to carry out the control mechanism to achieve the desired results with the respective chemical reactants. A common industry where batch reactors are used is the leather and tanning industry. The waste produced during the processing of leather is discharged into water bodies, causing great damage to marine life due to its highly hazardous nature. This waste can be first treated in the batch reactors to render it harmless to the marine environment and then later disposed off accordingly. This is one of the many applications and uses of the batch reactor.

Jeong et al.¹ had proposed a model predictive controller (MPC) for a nonlinear MIMO process using a Wiener model. The process considered was the polymerization reaction of MMA using benzoyl peroxide (BPO) as the initiator and ethyl acetate as the solvent. Wiener and Hammerstein models for the identification of the nonlinear chaotic systems have been designed by Rayouf et al.² The linear dynamic plant is considered to have the same order as that of the chaotic system. The static nonlinear system consists of a three-layer feedforward

neural network. The inputs to this neural network are delayed outputs from the plant model, and the outputs of the neural network are trained accordingly to track the chaotic systems. Peng et al.³ presented a Wiener-neural-network-based model predictive control (WNN-MPC) for a highly nonlinear plug flow tubular reactor. Li and Li⁴ designed a model predictive control (MPC) of an intensified continuously stirred tank reactor using a Wiener neural network model. The methodology of the process is that the Wiener neural network is trained to track the outlet conversion, and this model is incorporated in the model predictive controller (MPC) to carry out controller action. The neural network is trained using the Levenberg–Marquardt algorithm. Abu-Ayyad and Dubay⁵ had presented the various controllers that are currently used for industrial applications. The most commonly used controller is the PID controller that involves finding the gains of the respective proportional, integral, and derivative parts of the controller. Due to the issues faced by time delays and process lag time, the Smith

Received: December 19, 2021

Accepted: April 19, 2022

Published: May 3, 2022



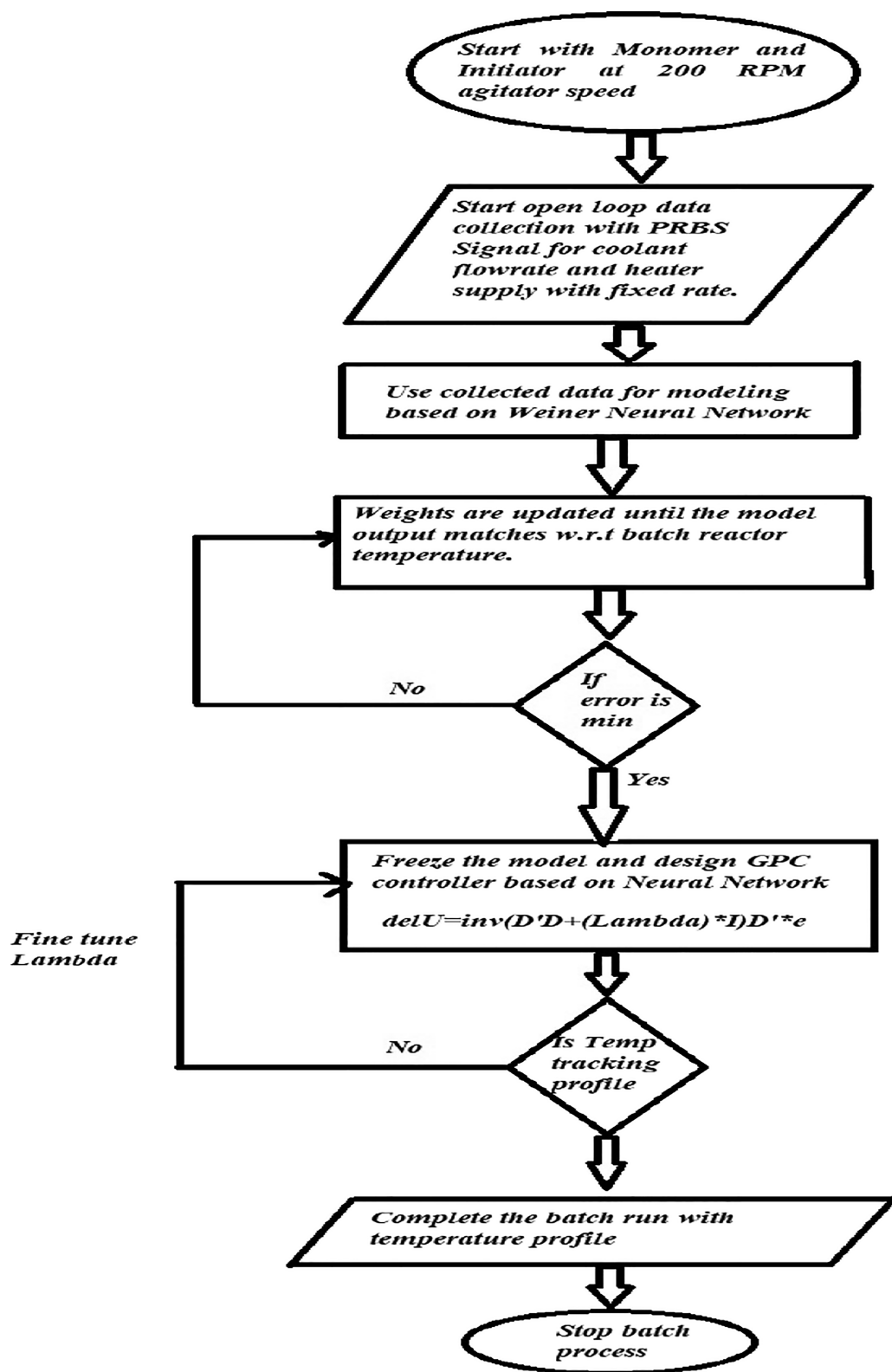

Figure 1. Flowchart of the methodology.

predictor found its application in the industries. The most commonly used controllers in the current scenario are the model predictive controller (MPC), generalized predictive controller (GPC), and dynamic matrix controller (DMC) that are based on the working of the generalized minimum variance (GMV) controller.^{6–9} The idea of the GMV controller is to minimize the

weighted squared errors. DMC is widely used in industries, but it faces issues due to its complexity as it has a high number of tuning parameters. Wei Jiang et al.¹⁰ had proposed an artificial-neural-network-based approach for a temperature control system. The error between the real-time system output and the designed reference model is used for the training of the

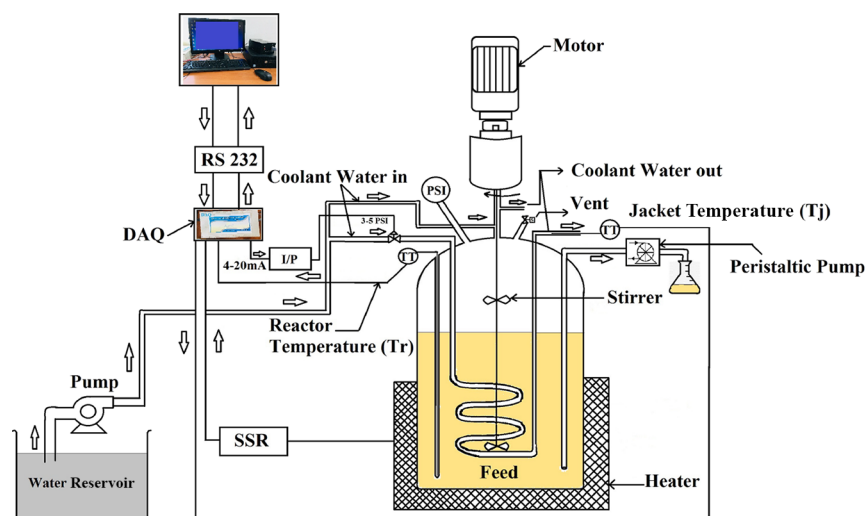
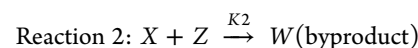
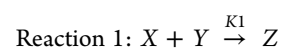

Figure 2. A schematic representation of the batch reactor.

artificial neural network (ANN) controller. Peng et al.¹¹ presented the identification and adaptive neural network control of a DC motor system with dead zone characteristics (DZCs). The paper proposes a design of two different neural networks: one for the identification of the system and the other to perform the adaptive control. The training of neural networks is done using the backpropagation algorithm. Since the system under consideration is discrete in nature, stability analysis is carried out using the Lyapunov theorem. Liu et al.¹² designed a multilayer feedforward neural-network-based predictive controller to efficiently perform pilot unit temperature control action. Modeling of the jacketed chemical reactor is carried out using the neural networks, and the controller action is carried out based on the minimization of quadratic performance criteria. Adamu et al.¹³ had predicted the estimation of turbidity in water treatment plants using Hammerstein–Wiener and neural network techniques. The measurement of the scattering of light when light is incident on a liquid sample is known as turbidity. The lesser the scattering of light is, the lesser is the turbidity of water. Janczak et al.¹⁴ proposed a Wiener model predictive control (WMPC) in a pH neutralization experiment. pH experiments are one of the most nonlinear processes to control; hence, Wiener modeling of the pH experiment is carried out followed by the incorporation of the model in the nonlinear Wiener model predictive controller (WMPC). A similar study has been carried out by Yu et al. where a neural-network-model-based predictive control scheme has been implemented to a laboratory-scaled multivariable chemical reactor.¹⁵ Dynamic optimization and neural network (NN) have been applied to improve the quality of the product of citric acid.¹⁶ The applications of hybrid models and corresponding simulation have been studied in the chemical domain.¹⁷ Methyl methacrylate production using a hybrid NN approach has been presented by Kittisupakorn et al.¹⁸ A GA-RBP neural network and improved gradient descent method has been presented as MPC for nonlinear application.¹⁹ Correspondingly,²⁰ the control of polystyrene batch reactors using NN-based model predictive control in an experimental approach has been shown. Another similar application of unloading gradient pressure in continuous gas-lift systems during petroleum production operations has been presented by Kamari et al.²¹ The NN-based MPC approach in pharmaceutical manufacturing has been presented by Wong et al.²²

The batch reactor has a highly nonlinear temperature profile (as evident from eq 1), and hence, tracking that profile is difficult. It is evident from the equation of the rate of reaction that is given below. Moreover, due to the dynamic nature of the set point (set point changes with time), an artificial-intelligence-based Wiener neural network algorithm is implemented for the dynamic nonlinear modeling of a pilot plant batch reactor.

$$k = A * e^{-E_a/RT} \quad (1)$$



where X and Y are reactants, Z is the product, $K1$ and $K2$ are reaction constants, E_a is the activation energy, A is the Arrhenius constant for a particular reaction, R is the gas constant, T is the temperature, and W is the unwanted byproduct whose production should be avoided, which is the main objective that can be achieved by optimal temperature control.

The methodology of the work is presented as a flowchart in Figure 1.

The working objective is that input–output data (input feed rate and reactor temperature respectively) are provided for the batch reactor for a particular reaction. Using a neural network model, weights need to be tuned for the respective neural network that would estimate an output equivalent to the output provided in the data set, which would result in minimal error and hence would ensure better modeling of the system and predict the output as closely and accurately as possible to the actual output.

A semi-batch reactor operates in a similar manner to a batch reactor. The only exception is that in a batch reactor, all the chemical reactants enter the storage tank at a single instant of time and the reactants cannot be altered in between the process mechanism, whereas in the case of a semi-batch reactor, partial filling of the reactants can be carried out along with the flexibility of adding or altering more chemical reactants at any time instant of the process mechanism. The apparatus is present in the Process Control Laboratory of MIT Manipal.

A schematic representation of a batch reactor shown in Figure 2 where the input reactants are "A" and "B" and the output reactant is "C". The desired control algorithm is carried out in

the reactor according to the results desired and also according to the compatibility and constraints of the reactants used. As a contribution, the temperature profile has been identified for the acrylamide polymerization using the WNN approach and the optimal control is achieved via GPC using WNN.

The batch reactor exhibits a dynamic and nonlinear response; hence, it is difficult to implement a control algorithm to control and predict the behavior of a batch reactor system. The artificial-intelligence-based Wiener neural network control algorithm ensures the prediction and efficient tracking of the output even for a nonlinear and dynamic system of the batch reactor. Another issue that is associated is that the batch reactor has a variable and dynamic set point (i.e., the set point is not constant throughout the process as in normal cases, and the set point keeps varying with time); hence, the tracking profile is more complicated. The ability of neural networks to solve such complex problems and find relationships between hidden layers is the reason why they are in high demand and are being studied currently, hence resulting in a large focus in research as well that aims at solving the most complex problems using them (Figure 3).



Figure 3. Lab-scale batch reactor in the Process Control Lab, MIT-Manipal.

2. METHODOLOGY

The algorithm is commonly known as the “backpropagation algorithm”. It can be used for linear as well as nonlinear classification. In the backpropagation algorithm, the error difference between the desired output and the calculated/estimated output is backpropagated. The procedure is repeated during the learning of the neural network to minimize the error by adjusting the weights throughout the backpropagation of the error. The only difference in the algorithm implemented is that it also remembers the change in the direction of weight at the next time instant, which is not done in the conventional backpropagation algorithm. Hence, the algorithm can be considered to be an extension of the backpropagation algorithm wherein even the change in the direction of weights is taken into account using the momentum factor (γ). The algorithm used allows the dynamic modeling of the system; i.e., with the change in set point, the weights are tuned dynamically to track the temperature profile successfully. Upon the incorporation of the weights in the controller design to find the dynamic matrix, the GPC can be tuned to track the dynamic set point successfully.

The algorithm employed to train the neural network consists of the steps mentioned below:

1. Identify the number of inputs, outputs, nonlinear static block parameters, and linear dynamic block parameters.
2. Based on step 1, draw the relevant Wiener neural network with all the inputs and their nodes at one side followed by the outputs and their respective nodes at the opposite side and the hidden layers and their respective nodes lying in between the input and output layers. The intermediate unmeasurable signal is the sum of previous weighted inputs along with the negative sum of the previous weighted intermediate unmeasurable signal. This unmeasurable signal acts as the input to the nonlinear static block, which finally gives the desired output.
3. Normalize the input–output data available from the batch reactor data set provided. Assign initial random weights to each and every interconnection of the nodes between the respective layers.
4. Find the output of the neural network with initially assigned weights (w 's). Find the error by comparing it with the desired normalized output.
5. Find the error produced due to each weight by finding ($\frac{\partial e(t)}{\partial w}$) using the chain rule of differentiation. Choose the learning rate (η) in the range (0,1]. The learning rate ensures how fast the neural network learns and trains itself with respect to the data. The higher the value of (η) is, the faster the neural network will be trained. Also, choose the momentum factor (γ) in the range (0,1]. Use these three factors to adjust the weights accordingly until the error reaches a permissible level.
6. When the weights are tuned in such a manner that the error is as small as possible, the output with this set of weights is calculated. This output acts as the estimated output ($\hat{y}(t)$), whereas the desired output ($y(t)$) is available from the PRBS data set that is provided. Hence, the error is calculated accordingly as well. w is the respective weight, whereas e is the error which is calculated as
7. Repeat steps 1–6 for the remaining samples of learning samples as well.
8. Incorporate the weights in the generalized predictive controller (GPC) to design the controller. The weights are used to formulate the dynamic matrix $D(t)$.
9. Based on the dynamic matrix calculated in step 8, the control law of GPC is implemented along with the appropriate tuning to ensure the satisfactory tracking of the set point profile.

2.1. Neural Network. 2.1.1. Artificial Neural Network (ANN).

- Inputs to the neural networks are arbitrarily chosen by the user according to the problem statement.
- The input layer is independent of the hidden layer values.
- Activation functions are mostly used to normalize values between a certain desirable range.
- Each input node is connected to every hidden layer node, and every hidden layer node is connected to the output layer node.

2.1.2. Wiener Neural Network (WNN).

- Delayed inputs and delayed intermediate values of the neural network are used as input to the WNN.
- Activation functions are not used in this case.

- Interconnection of every node is not required.
- Summation of the weighted delayed inputs and negative weighted delayed intermediate values acts as the intermediate unmeasurable signal. This acts as the input to the static nonlinear block. Based on the number of

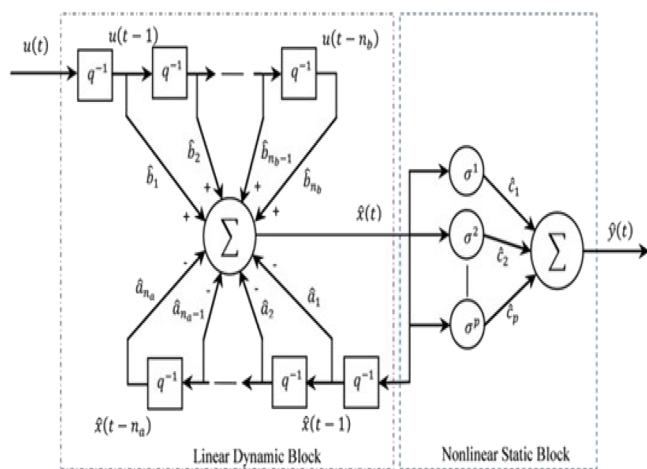

Figure 4. Structure of WNN. Reproduced from ref 3. Copyright 2011. American Chemical Society.

nodes in the nonlinear layer, the appropriate output is produced by the neural network (Figure 4).

$$x(t) = G(q^{-1})u(t) = \frac{B(q^{-1})}{A(q^{-1})}u(t) \quad (2)$$

where

$$A(q^{-1}) = 1 + a_1q^{-1} \dots + a_{n_a}q^{-n_a}$$

$$B(q^{-1}) = b_1q^{-1} + b_2q^{-2} \dots + b_{n_b}q^{-n_b}$$

$$y(t) = f(x(t))$$

where $f(\cdot)$ is a nonlinear function.

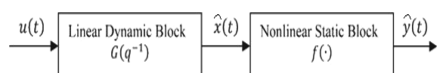

Figure 5. Simplified structure of WNN. Reproduced from 3. Copyright 2011. American Chemical Society.

From Figure 5, $u(t)$ is the input feed rate and $\hat{y}(t)$ is the reactor temperature. $\hat{x}(t)$ is the intermediate unmeasurable signal.

$$\hat{x}(t) = -\sum_{i=1}^{n_a} \hat{a}_i \hat{x}(t-i) + \sum_{j=1}^{n_b} \hat{b}_j \hat{u}(t-j) \quad (3)$$

$$\hat{y}(t) = f(\hat{x}(t)) = \sum_{k=1}^p \hat{c}_k \hat{x}^k(t) \quad (4)$$

Following are the parameters assumed for modeling:

$$n_a = 3 \text{ (linear dynamic block parameter)}$$

$$n_b = 3 \text{ (linear dynamic block parameter)}$$

$p = 2$ (nonlinear static block parameter)

Based on the assumptions made above, eqs 3 and 4 can be respectively modified as follows:

$$\hat{x}(t) = -\hat{a}_1 \hat{x}(t-1) - \hat{a}_2 \hat{x}(t-2) + \hat{b}_1 \hat{u}(t-1) + \hat{b}_2 \hat{u}(t-2) + \hat{b}_3 \hat{u}(t-3) \quad (5)$$

$$\hat{y}(t) = \hat{c}_1 \hat{x}(t) + \hat{c}_2 \hat{x}^2(t) \quad (6)$$

The main objective is to find the weights ($a_1, a_2, a_3, b_1, b_2, b_3, c_1, c_2$) such that the output of the WNN ($\hat{y}(t)$) is as close as possible to the desired output (y).

In some cases, the abbreviation w is used to denote weights as a whole rather than mentioning all the weights separately every time.

Note: The input–output data provided for batch reactor modeling are first normalized, and then the training of the neural network is carried out accordingly; at the end of the training of WNN, the values are denormalized again to their original values. This is done to ensure that the values obtained while training do not tend to $\pm\infty$, causing problems during simulation.

The WNN error (e) is as follows:

$$\hat{e}(t) = y(t) - \hat{y}(t) \quad (7)$$

where $y(t)$ is the desired output and $\hat{y}(t)$ is the WNN output.

The general weight updation formula to train the WNN is as follows:

$$\Delta w(t) = \eta \hat{e}(t) \frac{\delta \hat{y}(t)}{\delta w(t)} + \gamma \Delta w(t-1) \quad (8)$$

where

- η is the learning rate ranging from (0,1]
- $\hat{e}(t)$ is the WNN error as stated earlier
- $\hat{y}(t)$ is the WNN output as stated earlier
- $\gamma \Delta w(t-1)$ is the momentum factor that tracks the change in the direction of the weight in the earlier step.

$$w(t) = w(t-1) + \Delta w(t) \quad (9)$$

On substituting eq 8 into eq 9,

$$w(t) = w(t-1) + \gamma \Delta w(t-1) + \eta \hat{e}(t) \frac{\delta \hat{y}(t)}{\delta w(t)} \quad (10)$$

The partial derivative of the WNN output with the respective weights is calculated using eqs 3, 5, 4 and 6. If the partial derivative cannot be found directly using these equations, then the chain rule of differentiation is applied, and the partial derivative is then found by using the intermediate signal ($\hat{x}(t)$) accordingly. Using eq 4, the following two partial derivatives are obtained:

$$\frac{\partial \hat{y}(t)}{\partial \hat{c}_k} = \hat{x}^k(t) \quad (11)$$

where

$$k = 1, 2, 3, \dots, p$$

$$\frac{\partial \hat{y}(t)}{\partial \hat{x}(t)} = \sum_{k=1}^p k \hat{c}_k \hat{x}^{k-1}(t) \quad (12)$$

The partial derivative of the WNN output with the weights of linear dynamics cannot be found directly. Hence, the chain rule of partial differentiation is applied wherein the partial differentiation of the WNN output with the intermediate signal is

found (eq 12) followed by the partial differentiation of the intermediate signal with the linear dynamics. The mathematical form of the partial differentiation of the intermediate signal with the linear dynamic weights is given below:

$$\frac{\partial \hat{x}(t)}{\partial \hat{a}_i} = -\hat{x}(t-i) - \sum_{s=1}^{n_a} \hat{a}_s \frac{\partial \hat{x}(t-s)}{\partial \hat{a}_i} \quad (13)$$

where

$$i = 1, 2, 3 \dots n_a$$

$$\frac{\partial \hat{x}(t)}{\partial \hat{b}_j} = \hat{u}(t-j) - \sum_{s=1}^{n_b} \hat{b}_s \frac{\partial \hat{x}(t-s)}{\partial \hat{b}_j} \quad (14)$$

where

$$j = 1, 2, 3, \dots n_b$$

From eqs 12, 13, and 14, the partial derivatives are derived as follows:

$$\begin{aligned} \frac{\partial \hat{y}(t)}{\partial \hat{a}_i} &= \frac{\partial \hat{y}(t)}{\partial \hat{x}(t)} \frac{\partial \hat{x}(t)}{\partial \hat{a}_i} \\ &= \left[\sum_{k=1}^p k \hat{c}_k \hat{x}^k - 1(t) \right] \\ &\quad \left[-\hat{x}(t-i) - \sum_{s=1}^{n_a} \hat{a}_s \frac{\partial \hat{x}(t-s)}{\partial \hat{a}_i} \right] \end{aligned} \quad (15)$$

where

$$\begin{aligned} \frac{\partial \hat{y}(t)}{\partial \hat{b}_j} &= \frac{\partial \hat{y}(t)}{\partial \hat{x}(t)} \frac{\partial \hat{x}(t)}{\partial \hat{b}_j} \\ &= \left[\sum_{k=1}^p k \hat{c}_k \hat{x}^k - 1(t) \right] \cdot \left[\hat{u}(t-j) - \sum_{s=1}^{n_b} \hat{b}_s \frac{\partial \hat{x}(t-s)}{\partial \hat{b}_j} \right] \end{aligned} \quad (16)$$

Based on the partial derivatives derived in eqs 11, 15, and 16, the weight updation law (eq 10) can be modified as follows:

$$\hat{c}_k(t) = \hat{c}_k(t-1) + \eta_c \hat{e}(t) \frac{\delta \hat{y}(t)}{\delta \hat{c}_k} + \gamma \Delta \hat{c}_k(t-1) \quad (17)$$

where

$$k = 1, 2, 3, \dots p$$

$$\hat{b}_j(t) = \hat{b}_j(t-1) + \eta_b \hat{e}(t) \frac{\delta \hat{y}(t)}{\delta \hat{b}_j} + \gamma \Delta \hat{b}_j(t-1) \quad (18)$$

where

$$j = 1, 2, 3, \dots n_b$$

$$\hat{a}_i(t) = \hat{a}_i(t-1) + \eta_a \hat{e}(t) \frac{\delta \hat{y}(t)}{\delta \hat{a}_i} + \gamma \Delta \hat{a}_i(t-1) \quad (19)$$

where

$i = 1, 2, 3, \dots n_a$ Equations 17, 18, and 19 are used to find the Wiener neural network (WNN) weights. The objective is to keep tuning the weights until the error from the WNN is as low as possible. This constitutes the modeling of the batch reactor using the Wiener neural network (Figure 6).

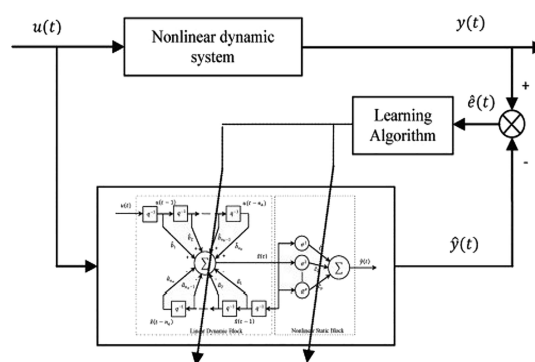

Figure 6. System identification using WNN. Reproduced from 3. Copyright 2011. American Chemical Society.

3. WNN-BASED GENERALIZED PREDICTIVE CONTROL (WGPC)

The GPC is one of the most successful and commonly used controllers in the industry. The main objective of the GPC in this case is to effectively track any arbitrary set point profile. It is based on the controlled auto regressive integrated moving average (CARIMA) model. Given below is a schematic diagram of the closed loop system for WNN-based GPC (WGPC) (Figure 7).

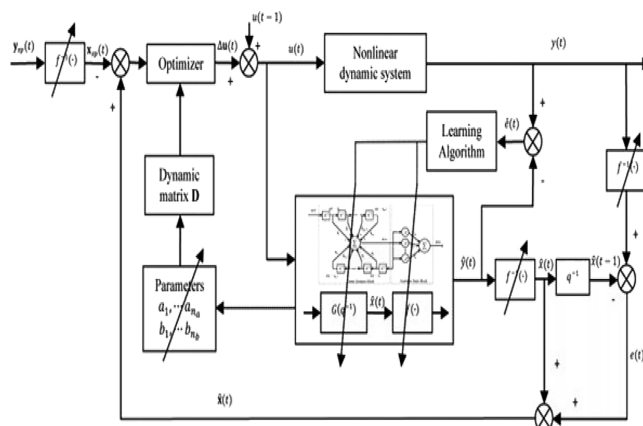

Figure 7. Structure of WNN-based GPC for the nonlinear system. Reproduced from 3. Copyright 2011. American Chemical Society.

The CARIMA model has a structure similar to the linear dynamic block of the WNN. Hence, the GPC is designed to predict values of the linear dynamic block. This can be done using the inverse of the nonlinear function ($f^{-1}(\cdot)$) from eq 2.

The order and contents of the dynamic matrix $D(t)$ that is used to design the GPC are given below:

$$D(t) = \begin{bmatrix} d_1(t) & 0 & \dots & 0 \\ d_2(t) & d_1(t) & \dots & 0 \\ \vdots & \vdots & \ddots & \vdots \\ \vdots & \vdots & \dots & \vdots \\ d_N(t) & d_{N-1}(t) & \dots & d_{N-N_u+1}(t) \end{bmatrix} \quad (20)$$

where

N = prediction horizon

N_u = control horizon

and

$$d_j(t) = - \sum_{i=1}^{\min(f-1, n_a)} \hat{a}_i(t) d_{j-1}(t) + \sum_{i=1}^{\min(j, n_b)} \hat{b}_i(t) \quad (21)$$

where

$$j = 1, 2, \dots, N$$

The cost function is expressed as:

$$\begin{aligned} J(t) = & (D(t)\Delta u(t) + x_0(t) - x_{sp}(t))^T (D(t)\Delta u(t) + x_0(t) \\ & - x_{sp}(t)) + \lambda \Delta u^T(t) \Delta u(t) \Delta u^T(t) (D^T(t)D(t) \\ & + \lambda I) \Delta u(t) + 2(x_0(t) - x_{sp}(t))^T \Delta u(t) \\ & + (x_0(t) - x_{sp}(t))^T (x_0(t) - x_{sp}(t)) \end{aligned} \quad (22)$$

By minimizing the cost function $J(t)$, the control law of GPC is obtained as given below:

$$\Delta u(t) = (D^T(t)D(t) + \lambda I)^{-1} D^T(t) (x_{sp}(t) - x_0(t)) \quad (23)$$

where

$D(t)$ is obtained using eq 21

λ is a tuning parameter that can be adjusted accordingly

I is the identity matrix

$x_0(t)$ is the free response dependent only on past moves with an initial input = zero

$$x_{sp}(t) = [x_{sp}(t+1), \dots, x_{sp}(t+N)]^T$$

and

$$x_{sp}(t) = f^{-1}(y_{sp})$$

Finally,

$$\hat{X}(t) = D(t)\Delta u(t) - x_0(t) \quad (24)$$

The main objective of the controller is that $\hat{X}(t)$ should be equal to $x_{sp}(t)$. Then $\hat{X}(t)$ is given as the input to the nonlinear static block of the WNN with the same nonlinear block parameters to get the WNN output. Now, the output is denormalized back to the original range. This will make the controller track the arbitrary temperature set point profile.

4. RESULTS AND DISCUSSION

The aim is to initially find the weights for the Wiener neural network that successfully track the temperature profile provided from the existing data set. This process is known as the modeling/system identification of the batch reactor process. Secondly, the weights obtained from the modeling are incorporated in the generalized predictive controller (GPC) to track the arbitrary set point profile. The results section is divided into two parts: Part A consists of the results obtained during the modeling of the batch reactor to satisfactorily track the data set temperature profile. Part B consists of the results obtained during the design of the generalized predictive controller. The tracking performance of the controller with respect to various set point profiles can be examined.

4.1. Model Parametrization of the Batch Reactor Using WNN. An input–output data set was provided for an earlier conducted experiment on the lab-scale batch reactor. The Wiener neural network (WNN) is trained with the advanced backpropagation algorithm to track the output from the provided data set. The input is the input feed rate, and the

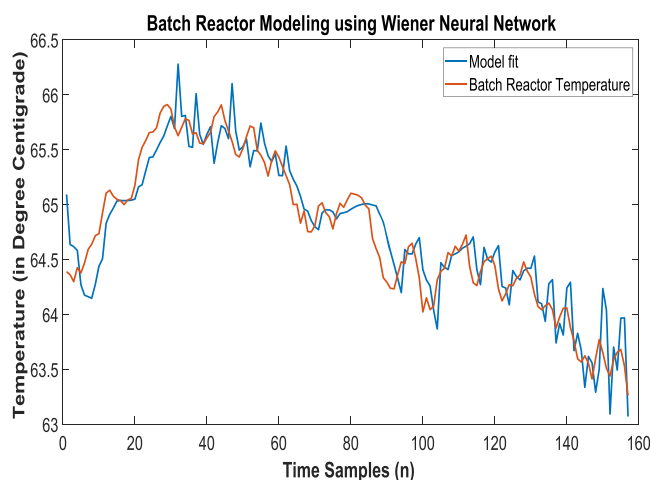

Figure 8. Comparison of the actual and model data set for modeling a batch reactor using WNN.

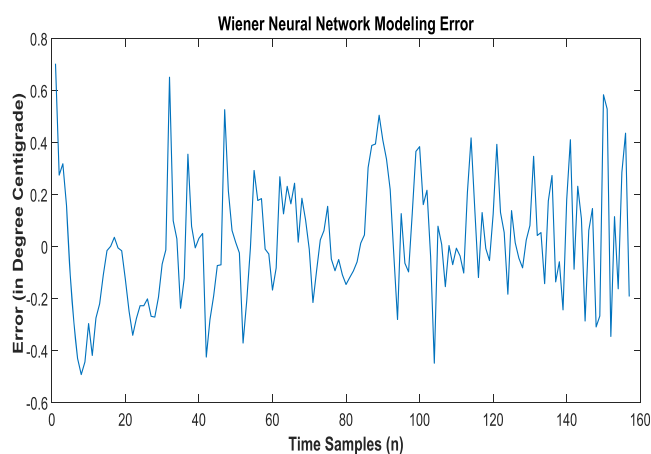

Figure 9. Error obtained between the actual and model data set of the WNN model.

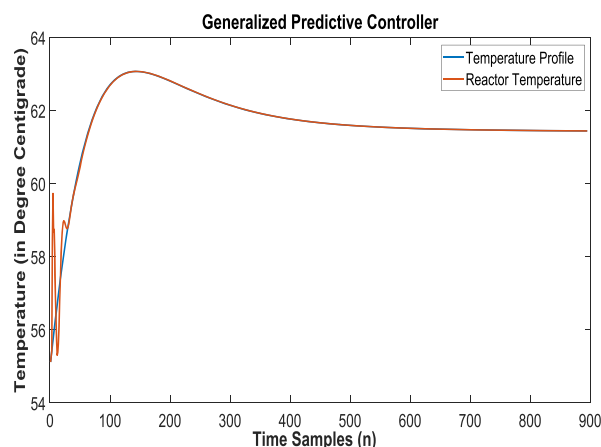

Figure 10. Tracking performance of GPC for an arbitrary temperature profile.

output is the batch reactor temperature. The temperature profile to be tracked is highly nonlinear, which adds to the complexity of the problem statement as well. The data set provided has 161 fields. The maximum permissible error is considered to be around 0.5 °C for most of the fields in the data set except for

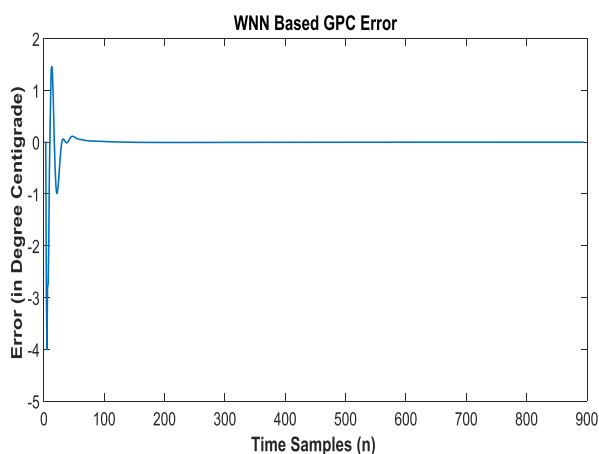

Figure 11. Error plot of WGPC for the temperature profile set point.

some fields (especially in the start and the end of the training of WNN).

Based on the data set provided and the assumptions made (as stated in the methodology) and after meticulously following the methodology, the tracking profile is obtained for the input–output data set (Figure 8).

The weights of the Wiener neural network for the provided input–output data set are obtained using eqs 17, 18, and 19. On solving these equations in the MATLAB interface to get the optimal tracking performance, the following weights are obtained for the given data set: $\hat{a}_1 = -0.3076$; $\hat{a}_2 = -0.1306$;

$\hat{a}_3 = -0.3585$; $\hat{b}_1 = -0.3138$; $\hat{b}_2 = -1.1216$; $\hat{b}_3 = -0.2703$; $\hat{c}_1 = 0.1051$; and $\hat{c}_2 = -0.0525$.

The graph below shows the variation of error of the Wiener neural network along different time samples (Figure 9).

4.2. WNN-Based GPC Control. For the designing of GPC, the following assumptions are considered: prediction horizon (N) = 5 and control horizon (N_u) = 3. The graph given below shows the tracking performance of the WNN-based GPC for an arbitrary set point profile.

The variation of error with respect to the tracking of the temperature profile in Figure 10 is given in Figure 11.

The graph below shows the response of the manipulated variable (MV) signal for controller tracking shown in Figure 10 (Figure 12).

The proposed neural network model tracks the desired output satisfactorily with the following observed error specifications: maximum observed error (for training WNN) = 0.703413 °C, minimum observed error (for training WNN) = 0.001282 °C, average observed error (for training WNN) = 0.203271 °C, maximum observed error (for WGPC set point profile tracking) = 4.006069 °C, minimum observed error (For WGPC set point profile tracking) = 6.39209×10^{-5} °C, average observed error (for WGPC set point profile tracking) = 0.037184 °C, maximum observed error (for WGPC constant set point) = 0.896911 °C, minimum observed error (for WGPC constant set point) = 0 °C, and average observed error (for WGPC constant set point) = 0.007803 °C.

The real-time process variable response of generalized predictive control on the lab-scale batch reactor is shown in

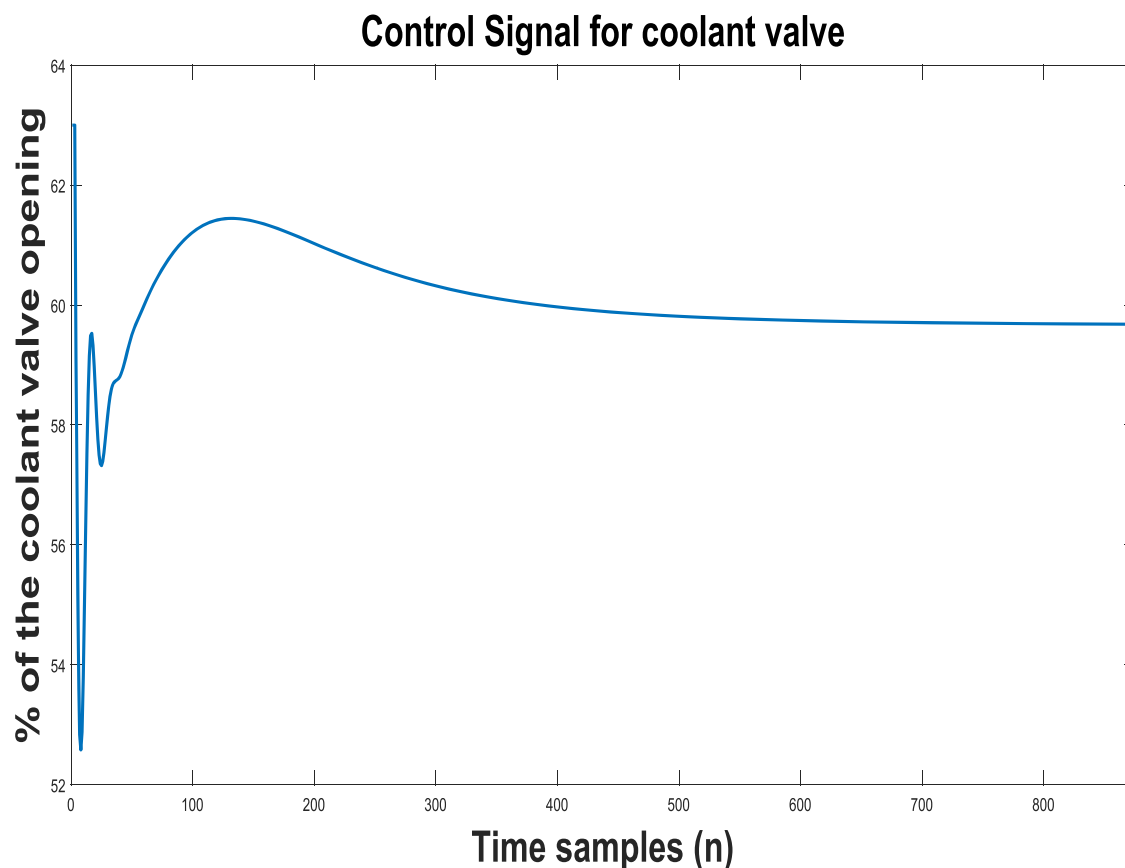

Figure 12. Manipulated variable response of the batch reactor.

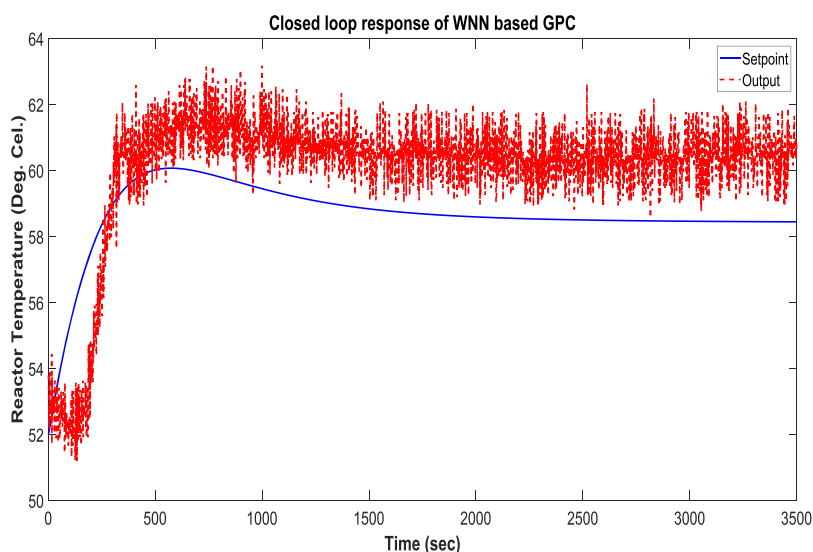

Figure 13. Real-time response of the WNN-GPC controller process variable.

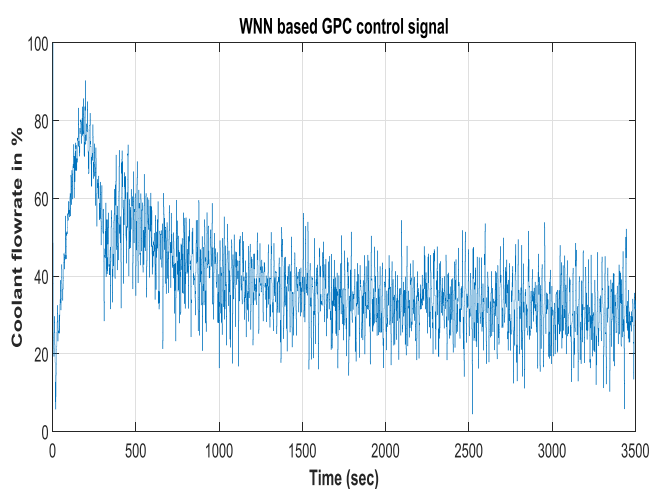

Figure 14. Real-time response of the WNN-GPC controller manipulated variable.

Figure 13, and the corresponding manipulated variable response is given in Figure 14.

The response shows the coolant valve opening based on the control signal generated from the WNN-based GPC. It was observed that the control signal is smooth over a time, which leads to the convergence of the process variable without much oscillations.

The advantage of the methodology is that the continuous weight will be updated with respect to the dynamic characteristics of the plant. The limitations of the approach are that it requires more data for a more efficient model and that more time and effort are required for computation.

In the previous research of our work on the batch reactor, few oscillations in the process variable have been observed due the change in model which is not captured regularly for updates. In this WNN-based approach, the dynamic model is captured and the dynamic controller is designed so as to which will make the control variable to settle in line with the profile without much oscillations. In most pharmaceutical companies, refineries, and chemical industries, they use a batch reactor the most, and the common issue faced is the thermal runaway. Using the regularly updated and more precisely controlled algorithms such as WNN

prediction based controllers, one can be able to maintain the temperature of the reactor in a controlled manner to avoid any thermal runaway. The energy consumption with respect to the thermal input still remains challenging in most industries, which can be reduced by effective machine learning, deep learning, and neural network concepts for modeling and control.

5. CONCLUSIONS

The work methodology deployed was the advanced back-propagation algorithm. This algorithm involves assuming weights for the neural network and then finding the output and the respective error along with the change in the direction of weights in the former step. The error due to each of the assumed weights is calculated, and then the weights are adjusted based on this factor. The algorithm is repeated until the error reaches a permissible level/value to carry out further operation.

1. The output from the neural network satisfactorily tracks the desired output from the data set.
2. The average error associated with the training of the neural network is found to be 0.203271 °C.
3. The WNN-based GPC (WGPC) is able to track any kind of temperature set point satisfactorily. Hence, the nonlinear tracking of the temperature profile is successfully carried out using the modeling of the batch reactor and designing of the generalized predictive controller.
4. The simulation and experimental validation of the WNN-based GPC controller on the pilot plant give satisfactory tracking with the optimal control signal.

6. FUTURE WORK

At present, only a servo operation is presented in this work. As a future work, load operation would be carried out to analyze the product conversion rate. Hence, the online reoptimization of the temperature profile is needed to maximize the product conversion rate, which is one of the realistic problems in most of the process industries. Also, only the experimental temperature tracking is projected; the analytical characterization with respect to the product formed at the end of the batch process can be carried out with a viscometer, high-performance liquid chromatography, gas chromatography, etc. This work is under progress and planned to be presented in a future publication.

Support vector regression, a support vector machine, and principal component analysis could be used to increase the productive outcome.

Along with this, the experimental setup of the batch reactor can be further used for the novel catalyst synthesis and biodiesel production toward the product development. Soft sensing nonlinear estimators can also be implemented for measuring the concentration of the product produced.

AUTHOR INFORMATION

Corresponding Author

Thirunavukkarasu Indiran – *Advanced Process Control Lab, Department of Instrumentation and Control Engineering, Manipal Institute of Technology, Manipal Academy of Higher Education, Manipal 576104, India*; orcid.org/0000-0002-1829-7362; Email: it.arasu@manipal.edu

Authors

Prajwal Shettigar J – *Department of Mechatronics Engineering, Manipal Institute of Technology, Manipal Academy of Higher Education, Manipal 576104, India*; orcid.org/0000-0003-1494-5569

Jatin Kumbhare – *Advanced Process Control Lab, Department of Instrumentation and Control Engineering, Manipal Institute of Technology, Manipal Academy of Higher Education, Manipal 576104, India*

Eadala Sarath Yadav – *EEV2 Department, Bosch Global Software Technologies, Bangalore 560103, India*; orcid.org/0000-0001-7157-5395

Complete contact information is available at:

<https://pubs.acs.org/10.1021/acsomega.1c07149>

Notes

The authors declare no competing financial interest.

ACKNOWLEDGMENTS

The authors would like to express gratitude to the Manipal Academy of Higher Education (MAHE) for the seed money grant toward the batch reactor experimental setup under Grant ID: 00000220 dated 1/1/2020. We express our sincere gratitude to Prof. Dr. J. Prakash, Anna University, Chennai, for giving us the right steering with technical inputs on the batch reactor and Prof. R. Vinodha, Annamalai University for inputs on Neural Networks part.

NOMENCLATURE

ANN	artificial neural network
BP	backpropagation
BPO	benzoyl peroxide
CARIMA	controlled auto regressive integrated moving average
CSTR	continuous stirred tank reactor
DMC	dynamic matrix controller
DSP	digital signal processor
DZC	dead zone characteristic
FOPDT	first order plus dead time
GMV	generalized minimum variance
GPC	generalized predictive controller
MMA	methyl methacrylate
MPC	model predictive controller
MV	manipulated variable
PID	proportional integral derivative controller
SVM	support vector machine

SVR	support vector regression
w	weight
WGPC	Wiener-neural-network-based generalized predictive controller
WMPC	Wiener-neural-network-based model predictive controller
WNN	Wiener neural network

REFERENCES

- (1) Jeong, B.-G.; Yoo, K.-Y.; Rhee, H.-K. Nonlinear model predictive control using a Wiener model of a continuous methyl methacrylate polymerization reactor. *Ind. Eng. Chem. Res.* **2001**, *40*, 5968–5977.
- (2) Rayouf, Z.; Ghorbel, C.; Benhadj Braiek, N. Nonfragile Stabilizing Nonlinear Systems Described by Multivariable Hammerstein Models. *Complexity* **2021**, *2021*, 1.
- (3) Peng, J.; Dubay, R.; Hernandez, J. M.; Abu-Ayyad, M. A Wiener neural network-based identification and adaptive generalized predictive control for nonlinear SISO systems. *Ind. Eng. Chem. Res.* **2011**, *50*, 7388–7397.
- (4) Li, S.; Li, Y.-Y. Neural network based nonlinear model predictive control for an intensified continuous reactor. *Chem. Eng. Process.: Process Intensif.* **2015**, *96*, 14–27.
- (5) Abu-Ayyad, M.; Dubay, R. Real-time comparison of a number of predictive controllers. *ISA Trans.* **2007**, *46*, 411–418.
- (6) Yadav, E. S.; Indiran, T.; Priya, S. S. Optimal Energy Consumption of the Distillation Process and Its Product Purity Analysis Using Ultraviolet Spectroscopy. *ACS Omega* **2021**, *6*, 1697–1708.
- (7) Yadav, E. S.; Indiran, T.; Priya, S. S.; Fedele, G. Parameter Estimation and an Extended Predictive-Based Tuning Method for a Lab-Scale Distillation Column. *ACS Omega* **2019**, *4*, 21230–21241.
- (8) Yadav, E. S.; Shettigar, J. P.; Poojary, S.; Chokkadi, S.; Jeppu, G.; Indiran, T. Data-Driven Modeling of a Pilot Plant Batch Reactor and Validation of a Nonlinear Model Predictive Controller for Dynamic Temperature Profile Tracking. *ACS Omega* **2021**, *6*, 16714–16721.
- (9) Shettigar, J. P.; Lochan, K.; Jeppu, G.; Palanki, S.; Indiran, T. Development and Validation of Advanced Nonlinear Predictive Control Algorithms for Trajectory Tracking in Batch Polymerization. *ACS Omega* **2021**, *6*, 22857–22865.
- (10) Xu, S.; Hashimoto, S.; Jiang, Y.; Izaki, K.; Kihara, T.; Ikeda, R.; Jiang, W. A reference-model-based artificial neural network approach for a temperature control system. *Processes* **2020**, *8*, 50.
- (11) Peng, J.; Ding, S.; Dubay, R. Adaptive composite neural network disturbance observer-based dynamic surface control for electrically driven robotic manipulators. *Neural Computing and Applications* **2021**, *33*, 6197–6211.
- (12) Liu, W.; Ma, L.; Li, J.; Wang, T.; Ding, L. Artificial neural network-based adaptive fluid temperature regulation of extravehicular activity suit. *Medicine in Novel Technology and Devices* **2021**, *12*, No. 100096.
- (13) Adamu, M.; Haruna, S.; Malami, S. I.; Ibrahim, M.; Abba, S.; Ibrahim, Y. E. Prediction of compressive strength of concrete incorporated with jujube seed as partial replacement of coarse aggregate: a feasibility of Hammerstein–Wiener model versus support vector machine. *Modeling Earth Systems and Environment* **2021**, *1*–11.
- (14) Janczak, A. *Identification of nonlinear systems using neural networks and polynomial models: a block-oriented approach*; Springer Science & Business Media, 2004; Vol. 310.
- (15) Yu, D.; Gomm, J. Implementation of neural network predictive control to a multivariable chemical reactor. *Control Engineering Practice* **2003**, *11*, 1315–1323.
- (16) Daosud, W.; Thammasato, J.; Kittisapakorn, P. Neural network based modeling and control for a batch heating/cooling evaporative crystallization process. *Eng. J.* **2017**, *21*, 127–144.
- (17) Zendeheboudi, S.; Rezaei, N.; Lohi, A. Applications of hybrid models in chemical, petroleum, and energy systems: A systematic review. *Appl. Energy* **2018**, *228*, 2539–2566.

(18) Kittisupakorn, P.; Charoenniyom, T.; Daosud, W. Hybrid neural network controller design for a batch reactor to produce methyl methacrylate. *Eng. J.* **2014**, *18*, 145–162.

(19) Wang, Y.; Qing, D. Model predictive control of nonlinear system based on GA-RBP neural network and improved gradient descent method. *Complexity* **2021**, *2021*, 1.

(20) Hosen, M. A.; Hussain, M. A.; Mjalli, F. S. Control of polystyrene batch reactors using neural network based model predictive control (NNMPC): An experimental investigation. *Control Engineering Practice* **2011**, *19*, 454–467.

(21) Kamari, A.; Bahadori, A.; Mohammadi, A. H.; Zendehboudi, S. Evaluating the unloading gradient pressure in continuous gas-lift systems during petroleum production operations. *Pet. Sci. Technol.* **2014**, *32*, 2961–2968.

(22) Wong, W. C.; Chee, E.; Li, J.; Wang, X. Recurrent neural network-based model predictive control for continuous pharmaceutical manufacturing. *Mathematics* **2018**, *6*, 242.