

SCIENTIFIC REPORTS



OPEN

Divergent Synthesis of Chondroitin Sulfate Disaccharides and Identification of Sulfate Motifs that Inhibit Triple Negative Breast Cancer

Received: 17 June 2015

Accepted: 24 August 2015

Published: 24 September 2015

Zhong Wei Poh^{1,2}, Chin Heng Gan¹, Eric J. Lee¹, Suxian Guo³, George W. Yip³ & Yulin Lam^{1,2}

Glycosaminoglycans (GAGs) regulate many important physiological processes. A pertinent issue to address is whether GAGs encode important functional information via introduction of position specific sulfate groups in the GAG structure. However, procurement of pure, homogenous GAG motifs to probe the “sulfation code” is a challenging task due to isolation difficulty and structural complexity. To this end, we devised a versatile synthetic strategy to obtain all the 16 theoretically possible sulfation patterns in the chondroitin sulfate (CS) repeating unit; these include rare but potentially important sulfated motifs which have not been isolated earlier. Biological evaluation indicated that CS sulfation patterns had differing effects for different breast cancer cell types, and the greatest inhibitory effect was observed for the most aggressive, triple negative breast cancer cell line MDA-MB-231.

Glycosaminoglycans (GAGs) are heterogeneous polysaccharides comprising of repeating uronic acid and amino sugar disaccharide units. These macromolecules can be covalently attached to core proteins to form proteoglycan side chains, or located in the extracellular matrix and intracellular secretory granules^{1–3}. GAGs have gained interest as potential therapeutic agents in cancer treatment, with studies showing their involvement in various pathobiological cancer stages^{4,5}, and interactions with various effective molecules such as growth factors and cytokines^{6,7}. Overexpression of chondroitin sulfate (CS) has been identified in various cancer phenotypes such as prostate, testicular, gastric, pancreatic and breast cancer^{8–12}. For instance, compositional analysis of GAG side chains isolated from malignant breast tissues indicate an elevation in CS expression^{13–15}, with an increase in CS-A and CS-E sulfation sequences and a decrease in CS-C and CS-D^{16–18}. These indicate that the sulfate groups present on CS might play an important role in the cellular processes involved in the progression of breast cancer^{7,8,19,20}.

To investigate the molecular interactions of CS, chemical synthesis provides a viable alternative to prepare pure, homogenous CS sequences via careful control on the site(s) of sulfation to probe structural activity relationship. Notable work has been achieved by various groups in the synthesis of different CS analogues, such as CS-A, CS-C, CS-D, CS-E, CS-R, CS-K, CS-L, CS-M^{21–34} and some of these analogues have been studied for their biological effects^{24,35,36}. However, based on the current synthetic strategies reported, not all the sulfation patterns possible in the CS repeating unit can be obtained. We opined that CS sulfation motifs which are not commonly expressed could encode important regulatory information.

¹Department of Chemistry, National University of Singapore (NUS), Singapore. ²NUS Graduate School for Integrative Sciences and Engineering (NGS), Singapore. ³Department of Anatomy, National University of Singapore (NUS), Singapore. Correspondence and requests for materials should be addressed to G.W.Y. (email: georgeyip@nus.edu.sg) or Y.L. (email: chmlamyl@nus.edu.sg)

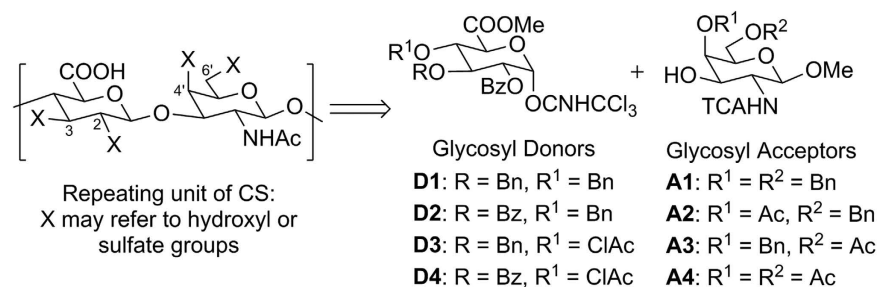

Figure 1. Glycosyl donors and acceptors for CS disaccharide library synthesis.

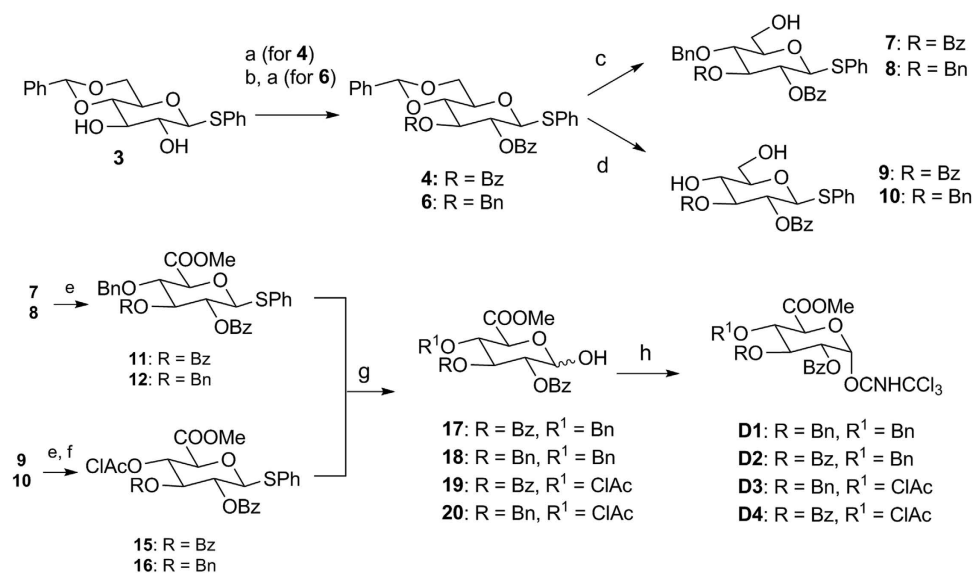

Figure 2. Synthesis of glycosyl donors **D1–D4**. Reagents and conditions: (a) Bz₂O, DMAP, CH₂Cl₂, **4**: 88%; (b) Bu₂SnO, toluene, 90 °C, then BnBr, CsF, DMF, **6**: 57% (3 steps); (c) BH₃.THF, CoCl₂, **7**: 72%, **8**: 75%; (d) TFA, CH₂Cl₂/H₂O, **9**: 84%, **10**: 88% (e) TEMPO, BAIB, CH₂Cl₂/H₂O, then MeI, NaHCO₃, TBAI, DMF, 50 °C, **11**: 48%, **12**: 55%, (f) Cl₂Ac₂O, pyridine, CH₂Cl₂, **15**: 45%, **16**: 48% (3 steps); (g) NIS, TFA, CH₂Cl₂/H₂O, **17**: 74%, **18**: 70%, **19**: 77%, **20**: 75%; (h) Cl₃CCN, DBU, CH₂Cl₂, **D1**: 68%, **D2**: 75%, **D3**: 70%, **D4**: 78%.

Thus, we envisioned a synthetic strategy which would allow for the synthesis of all the sulfation patterns possible in CS.

In CS, sulfation may occur on the C-2, C-3 positions of D-glucuronic acid and the C-4', C-6' positions of D-N-acetyl galactosamine (Fig. 1) thus accounting for a total of 16 disaccharide possibilities. As with other saccharide synthesis, many key protection steps are required to control the site of sulfation in the desired analogue^{37–39}. Our synthetic strategy utilizes the benzyl ether and ester protecting groups as orthogonal handles to direct regioselective sulfation in the final product. Prior research work has demonstrated that the C-2 ester directing group is pivotal to direct β -stereoselective glycosylation^{25,34}. Since C-2 may contain a sulfate group, ester protected hydroxyl groups are thus required as both sulfation and non-sulfation sites depending on the target compound. With this in mind, we modified some of the currently available CS precursors^{24,31,35,38,40,41} to obtain glycosyl donors **D1–D4** and acceptors **A1–A4**; these building blocks enable the synthesis of all 16 sulfation patterns theoretically possible in the CS repeating unit.

Results and Discussion

Synthesis of monomeric building blocks. To obtain the glycosyl donors, intermediate **3** (Fig. 2) was subjected to different protection steps in a divergent mode. C-2 ester protection was required for all 4 donors to direct β -stereoselective glycosylation, and the C-3 hydroxyl group was protected either as an ester or a benzyl ether via the dibutyl tin oxide mediated approach⁴². For **D1** and **D2**, ester protected hydroxyl groups were denoted as sulfation sites; hence an orthogonal benzyl ether protecting group was required on C-4, achieved by the use of CoCl₂ and BH₃.THF to direct complete regio-reductive ring opening of the benzylidene acetal protecting group^{43,44} (intermediates **7** and **8**). Conversely, **D3** and **D4**

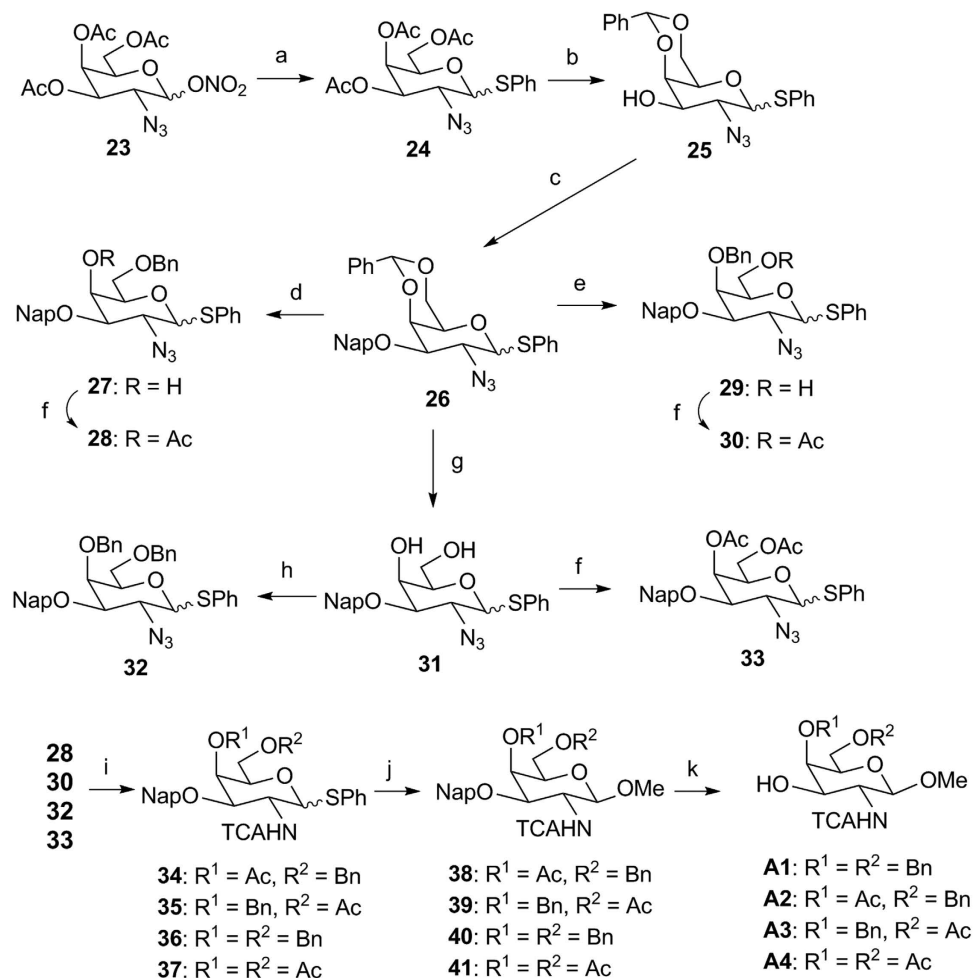

Figure 3. Synthesis of glycosyl acceptors A1–A4. Reagents and conditions: (a) NaOAc, AcOH, 80 °C, then PhSH, BF₃·OEt₂, CH₂Cl₂, 40 °C, 78%; (b) NaOMe, MeOH, then PhCH(OMe)₂, CSA, MeCN, 60 °C, 74%; (c) NapBr, NaH, DMF, 81%; (d) TES, TfOH, CH₂Cl₂, –78 °C, 78%; (e) TES, PhBCl₂, CH₂Cl₂, –78 °C, 68%; (f) Ac₂O, DMAP, CH₂Cl₂, **28**: 88%, **30**: 89%, **33**: 85%; (g) 80% AcOH, 80 °C, 90%; (h) BnBr, NaH, DMF, 75%; (i) Zn, NH₄Cl, EtOH/H₂O, 80 °C, then Cl₃COCl, TEA, THF, **34**: 54%, **35**: 58%, **36**: 55%, **37**: 60%; (j) NIS/TMSOTf, MeOH, CH₂Cl₂, –10 °C, **38**: 75%, **39**: 70%, **40**: 74%, **41**: 68%; (k) DDQ, H₂O, CH₂Cl₂, **A1**: 70%, **A2**: 69%, **A3**: 72%, **A4**: 68%.

mark benzyl ether protected hydroxyl groups as sulfation sites and hence require the orthogonal ester protection at C-4; chloroacetyl ester was chosen as this group could be selectively cleaved to allow for the synthesis of longer CS fragments when required^{45,46}. Intermediates **7**, **8**, **9**, **10** were subjected to C-6 oxidation and carboxylate methylation, followed by C-4 chloroacetylation (for intermediates **15** and **16**). This was followed by anomeric thiophenol deprotection and attachment of the trichloroacetimidate glycosyl auxiliary to furnish donors **D1–D4**.

To obtain the glycosyl acceptors, known intermediate **23**^{47–49} was modified to introduce key protecting groups in common intermediate **26** (Fig. 3). Regio-reductive ring opening of the benzylidene acetal in **26** enabled the formation of the benzyl ether on either the C-4' position or C-6' position depending on the choice of Lewis acid used. Ring opening using triethylsilane/TfOH system enabled the formation of the benzyl ether on the C-6' position in complete regioselectivity⁵⁰ (intermediate **27**), ascertained by 2D NMR. Alternatively, the benzyl ether could be obtained on the C-4' position with complete regioselectivity via triethylsilane/PhBCl₂ reductive system⁵⁰ (intermediate **29**). Protection of the corresponding hydroxyl groups as esters formed intermediates **28** and **30**. The benzylidene acetal could also be cleaved via acidic hydrolysis, with both hydroxyl groups protected as benzyl ethers or esters (**32** and **33**). The C-2' azide in intermediates **28**, **30**, **32** and **33** were next converted to the *N*-trichloroacetyl group (TCAHN), this C-2 participating group directed β -stereoselective glycosylation of the methyl ether at the anomeric position in the subsequent step. Finally, cleavage of the C-3' naphthyl ether via DDQ oxidation furnished glycosyl acceptors **A1–A4**.

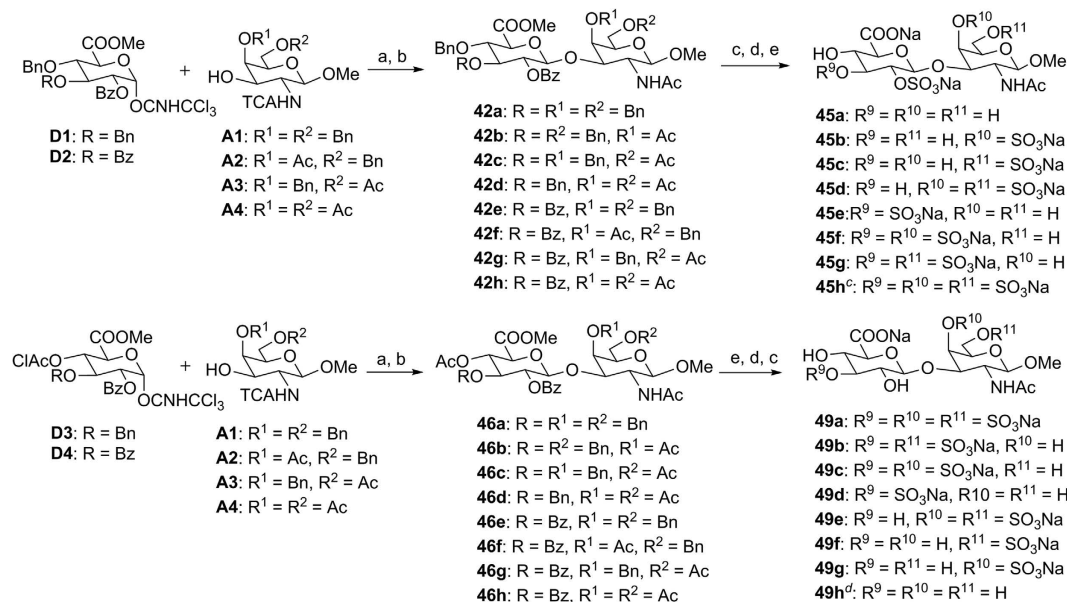

Figure 4. Synthesis of CS disaccharide analogues **45a–45h** and **49a–49h**. Reagents and conditions: (a) TMSOTf, 4 Å MS, CH₂Cl₂, –10 °C, 64–75%^b; (b) Bu₃SnH, ABCN, toluene, 100 °C, 69–80%^b; (c) LiOH, H₂O₂, THF/H₂O, –5 °C to r.t., then NaOH, MeOH, 0 °C to r.t., 72–79%^b; (d) SO₃.TEA, DMF, 50 °C, 68–77%^b; (e) H₂ gas, Pd/C, CH₂Cl₂/MeOH/H₂O, 85–95%^b; ^bFor detailed product yields refer to Supplementary Information; ^c**45h**: additional step (f): BnBr, NaHCO₃, DMF, 50 °C, after step (c); ^d**49h**: only step (c) was required to convert **46h** to **49h**.

Glycosylation of monomeric building blocks. With glycosyl donors **D1–D4** and glycosyl acceptors **A1–A4** on hand, any sulfation pattern required in the final CS disaccharide can be obtained by the judicious choice of donor and acceptor building blocks. **D1–D4** were first glycosylated with **A1–A4** using TMSOTf catalyst to form the protected disaccharides (Fig. 4). The C-2 participating ester group present in **D1–D4** enabled exclusive formation of the β -product²⁵. Upon glycosylation, the trichloroacetyl group was reduced to the acetyl group by radical mediated tributylstannane reduction. Any C-4 chloroacetyl groups present were also reduced to the form acetyl esters (intermediates **46a–46h**).

For intermediates **42a–42h**, the ester protecting groups were next liberated via basic hydrolysis and the free hydroxyl groups reacted with the sulfating agent. SO₃.TEA was utilised to enable complete sulfation of the C-2 hydroxyl group in the glucuronic acid moiety; 5 equiv. sulfating agent was required per –OH to ensure complete sulfation of the desired sites. Fortunately, the C-6 carboxylate group generated from the ester deprotection step did not affect the sulfation step. With the sulfate groups attached at the required positions, global deprotection by hydrogenation of the remaining benzyl ether groups proceeded in the final step to furnish 8 distinct CS disaccharides **45a–45h**. Due to the high negative charge in tetrasulfated disaccharide **45h**, an additional step was introduced to protect the C-6 carboxylate group as a benzyl ester, which facilitated product isolation during sulfation.

For intermediates **46a–46h**, the benzyl ethers were first cleaved via hydrogenation and the free hydroxyl groups were reacted with SO₃.TEA. Subsequently, global deprotection of the remaining ester protecting groups via basic hydrolysis⁵¹ furnished another 8 CS disaccharides **49a–49h**. Through this strategy, all 16 CS disaccharides were synthesized, which include those already reported^{21,30,52–55}, in addition to novel sulfation motifs. By the incorporation of orthogonal protecting groups in the monomeric building blocks, we were able to direct site specific sulfation of the CS disaccharide to obtain all the possible isomers, which were characterised by NMR and high resolution mass spectrometry (ESI) techniques. The complete CS disaccharide library thus enables us to probe the “sulfation code” of CS in biological systems via structural activity relationship studies.

Evaluating the CS disaccharide library on breast cancer cell viability. To achieve this, we proceeded to test the effect of CS sulfation patterns on breast cancer cell viability. The synthesized CS disaccharides were tested on 4 different human breast cell lines. This included the non-tumorigenic breast epithelial cell line MCF-12A, to evaluate compound cytotoxicity, and 3 breast cancer cell lines: MCF-7, T47D and MDA-MB-231. MCF-7 and T47D are low grade breast cancer cells which express the estrogen receptor and hence can be targeted using hormonal therapy^{56–59}. MDA-MB-231 cells are high grade triple negative breast cancer cells (TNBC) which do not express the estrogen receptor, progesterone receptor nor the human epidermal growth factor receptor^{260,61}. TNBC tumor subtypes show low response to

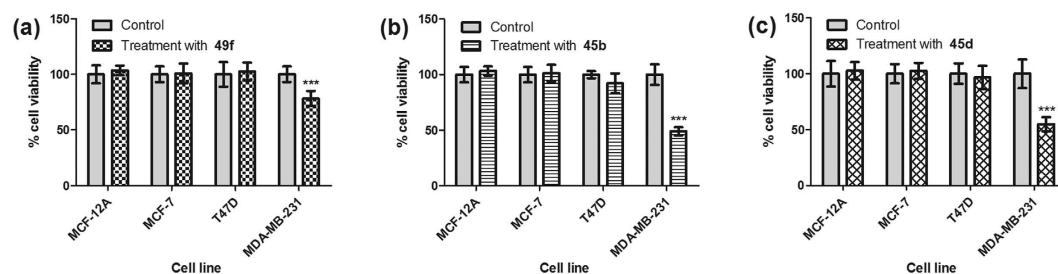

Figure 5. Cell viability assay results for MCF-12A, MCF-7, T47D and MDA-MB-231 cells. % cell viability after 72 hours treatment with 100 $\mu\text{g}/\text{mL}$ CS disaccharide (a) **49f**, (b) **45b**, (c) **45d**; Data represents the mean \pm SD ($n = 6$) with reference to non-treatment group (control), analyzed using one-way ANOVA with post-hoc Dunnett's test, *** $p < 0.01$.

chemotherapy and are more challenging to treat due to the lack of known therapeutic targets, thus resulting in higher patient mortality^{62–64}.

The biological effect of each CS disaccharide was investigated by incubating the cells with the CS disaccharide for 72 hours, prior to addition of the MTS reagent to determine number of viable cells after treatment period. 4 different CS disaccharide concentrations were tested (0.1 $\mu\text{g}/\text{mL}$, 1 $\mu\text{g}/\text{mL}$, 10 $\mu\text{g}/\text{mL}$ and 100 $\mu\text{g}/\text{mL}$). We first screened the 16 CS disaccharides on MCF-12A cells, and the results indicated that there was no significant change in cell viability (Supplementary Fig. 1). Hence these 16 CS disaccharides were not cytotoxic to normal breast cells.

Interestingly, when the 16 CS disaccharides were tested on the more aggressive MDA-MB-231 cell line, a statistically significant decrease in cell viability was observed (via one way ANOVA analysis) for CS disaccharides **49f**, **45b** and **45d** at 100 $\mu\text{g}/\text{mL}$ concentration (Fig. 5; Supplementary Fig. 2 and 3). These inhibitory effects suggest that the sulfate groups present on CS could encode important regulatory information for cellular processes involved in breast cancer survival. The results from the preliminary CS disaccharide screening also indicate that both the number and position of the sulfate groups present in the CS disaccharide have an effect on MDA-MB-231 cell viability. The non-sulfated and fully sulfated CS disaccharides, **49h** and **45h**, have no effect on cell viability suggesting that the presence of some sulfate groups are required for CS to elicit an inhibitory effect on MDA-MB-231 cells but saturating all the possible sulfation sites would lead to a loss of activity.

We next proceeded to screen the CS disaccharides on low grade breast cancer cells MCF-7 and T47D. The MTS results showed no change in the number of viable cells after treatment with the CS disaccharides, indicating that all 16 CS disaccharides had no significant effect on MCF-7 cells (Supplementary Fig. 4). The same observation was noted in T47D cells (Supplementary Fig. 5).

To further evaluate the active CS disaccharides (**49f**, **45b** and **45d**), apoptosis assays were subsequently conducted with the Caspase-Glo 3/7 kit which monitored the amount of caspase-3 and -7 activities present in the MDA-MB-231 cells after treatment with the respective CS disaccharides. Results from the caspase assay showed an increase in luminescence when MDA-MB-231 cells were treated with CS disaccharides **49f**, **45b** and **45d** (Fig. 6), indicating an increase in caspase-3 and -7 activities. This suggests that the CS disaccharides could induce death of breast cancer cells via apoptosis. Interestingly, the largest decrease in cancer cell viability and highest amount of caspase activity were seen in the CS disaccharide **45b**-treated group.

Conclusion

In summary, a versatile synthetic strategy has been devised for the chemical synthesis of all the sulfation patterns possible in the CS repeating unit. A total of 16 different CS disaccharides have been synthesized; these include analogues currently available as well as novel sulfation motifs. Biological evaluation indicated that CS sulfation patterns had differential effects on different types of breast cancer cells. High grade breast tumor cells (MDA-MB-231) showed significant reduction in cell viability upon treatment with CS disaccharides **49f**, **45b** and **45d** while low grade breast tumor cells (MCF-7, T47D) and normal breast cells (MCF-12A) were unaffected. Apoptosis assay suggests that these CS disaccharides could induce apoptosis. Since longer CS sequences could provide stronger activities than the disaccharides^{24,65}, further studies are presently ongoing to synthesize and evaluate CS oligosaccharides with the active sulfation profiles for their effect on MDA-MD-231 cells.

Methods

Chemical synthesis of CS disaccharides. Detailed experimental procedures and compound characterization data can be found in the supplementary information, available in the online version of the paper.

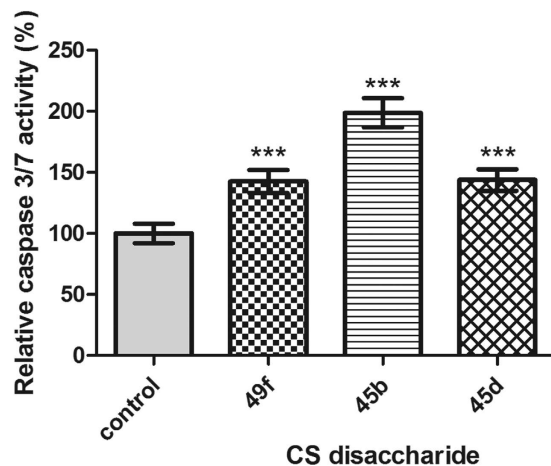

Figure 6. Caspase-Glo 3/7 assay results for MDA-MB-231 cells. Relative caspase 3/7 activity after 72 h treatment with 100 $\mu\text{g}/\text{mL}$ CS disaccharide **49f**, **45b** and **45d**. Data represents the mean \pm SD ($n = 6$) with reference to non-treatment group (control), analyzed using one-way ANOVA with post-hoc Dunnett's test, *** $p < 0.001$.

MTS Assay. The breast cells were plated onto a 96-well plate and cultured for 24 h. After 24 h, the cells were treated with the desired CS disaccharide at 4 different concentrations: 0.1 $\mu\text{g}/\text{mL}$, 1 $\mu\text{g}/\text{mL}$, 10 $\mu\text{g}/\text{mL}$ and 100 $\mu\text{g}/\text{mL}$. A control group was included where only the drug vehicle was used; 6 replicates were made for each data set ($n = 6$). Cells were treated with each compound for 72 hours, and then washed with phosphate-buffered saline (PBS). CellTiter 96[®] AQueous One Solution (MTS reagent) was added to each well. Absorbance readings ($\lambda = 490 \text{ nm}$) were taken after 3 h, and the data analyzed using one-way Analysis of Variance (ANOVA) with post-hoc Dunnett's test. Statistical significance was defined as $p < 0.05$.

Apoptosis Assay. MDA-MB-231 cells were plated on a 6-well plate and treated with the selected CS disaccharide at 100 $\mu\text{g}/\text{mL}$ concentration for 48 h. A control set was included where only the drug vehicle was used. After 48 h, the cells were collected by trypsinization, and reseeded into a white opaque 96-well plate to facilitate luminescence measurement ($n = 6$). After 24 h, 100 μL of Caspase-Glo[®] 3/7 reagent was added to each well, and then allowed to incubate for 1 h at room temperature in the dark. Luminescence readings were then measured.

References

- Kjellen, L. & Lindahl, U. Proteoglycans: structures and interactions. *Annu. Rev. Biochem.* **60**, 443–475 (1991).
- Iozzo, R. V. Matrix proteoglycans: From molecular design to cellular function. *Annu. Rev. Biochem.* **67**, 609–652 (1998).
- Kolset, S. O., Prydz, K. & Pejler, G. Intracellular proteoglycans. *Biochem. J.* **379**, 217–227 (2004).
- Iozzo, R. V. Basement membrane proteoglycans: from cellar to ceiling. *Nat. Rev. Mol. Cell Biol.* **6**, 646–656 (2005).
- Yang, J. *et al.* Melanoma chondroitin sulfate proteoglycan enhances FAK and ERK activation by distinct mechanisms. *J. Cell Biol.* **165**, 881–891 (2004).
- Asimakopoulou, A. P., Theocharis, A. D., Tzanakakis, G. N. & Karamanos, N. K. The biological role of chondroitin sulfate in cancer and chondroitin-based anticancer agents. *In Vivo* **22**, 385–389 (2008).
- Afratis, N. *et al.* Glycosaminoglycans: key players in cancer cell biology and treatment. *FEBS J.* **279**, 1177–1197 (2012).
- Svensson, K. J. *et al.* Chondroitin sulfate expression predicts poor outcome in breast cancer. *Int. J. Oncol.* **39**, 1421–1428 (2011).
- Ricciardelli, C. *et al.* Elevated stromal chondroitin sulfate glycosaminoglycan predicts progression in early-stage prostate cancer. *Clin. Cancer Res.* **3**, 983–992 (1997).
- Labropoulou, V. T. *et al.* Versican but not decorin accumulation is related to metastatic potential and neovascularization in testicular germ cell tumours. *Histopathology* **49**, 582–593 (2006).
- Theocharis, A. D., Tsara, M. E., Papageorgakopoulou, N., Karavias, D. D. & Theocharis, D. A. Pancreatic carcinoma is characterized by elevated content of hyaluronan and chondroitin sulfate with altered disaccharide composition. *Biochim. Biophys. Acta* **1502**, 201–206 (2000).
- Theocharis, A. D., Vynios, D. H., Papageorgakopoulou, N., Skandalis, S. S. & Theocharis, D. A. Altered content composition and structure of glycosaminoglycans and proteoglycans in gastric carcinoma. *Int. J. Biochem. Cell Biol.* **35**, 376–390 (2003).
- Alini, M. & Losa, G. A. Partial characterization of proteoglycans isolated from neoplastic and nonneoplastic human breast tissues. *Cancer Res.* **51**, 1443–1447 (1991).
- Olsen, E. B., Trier, K., Eldov, K. & Ammitzboll, T. Glycosaminoglycans in human breast cancer. *Acta Obstet. Gynecol. Scand.* **67**, 539–542 (1988).
- Cooney, C. A. *et al.* Chondroitin sulfates play a major role in breast cancer metastasis: a role for CSPG4 and CHST11 gene expression in forming surface P-selectin ligands in aggressive breast cancer cells. *Breast Cancer Res.* **13**, R58 (2011).
- Potapenko, I. O. *et al.* Glycan gene expression signatures in normal and malignant breast tissue; possible role in diagnosis and progression. *Mol. Oncol.* **4**, 98–118 (2010).
- Iida, J. *et al.* Role for chondroitin sulfate glycosaminoglycan in NEDD9-mediated breast cancer cell growth. *Exp. Cell Res.* **330**, 358–370 (2015).

18. Willis, C. M. & Klüppel, M. Chondroitin sulfate-E is a negative regulator of a pro-tumorigenic Wnt/Beta-catenin-collagen 1 axis in breast cancer cells. *PLoS ONE* **9**, e103966 (2014).
19. Prinz, R. D., Willis, C. M., Vilorio-Petit, A. & Klüppel, M. Elimination of breast tumor-associated chondroitin sulfate promotes metastasis. *Genet. Mol. Res.* **10**, 3901–3913 (2011).
20. Yip, G. W., Smollich, M. & Gotte, M. Therapeutic value of glycosaminoglycans in cancer. *Mol. Cancer Ther.* **5**, 2139–2148 (2006).
21. Jacquinet, J.-C., Lopin-Bon, C. & Vibert, A. From polymer to size-defined oligomers: a highly divergent and stereocontrolled construction of chondroitin sulfate A, C, D, E, K, L, and M oligomers from a single precursor: part 2. *Chem. - Eur. J.* **15**, 9579–9595 (2009).
22. Vibert, A., Lopin-Bon, C. & Jacquinet, J.-C. From polymer to size-defined oligomers: a step economy process for the efficient and stereocontrolled construction of chondroitin oligosaccharides and biotinylated conjugates thereof: part 1. *Chem. - Eur. J.* **15**, 9561–9578 (2009).
23. Jacquinet, J.-C., Rochepeau-Jobron, L. & Combal, J.-P. Multigram syntheses of the disaccharide repeating units of chondroitin 4- and 6-sulfates. *Carbohydr. Res.* **314**, 283–288 (1998).
24. Tully, S. E. *et al.* A chondroitin sulfate small molecule that stimulates neuronal growth. *J. Am. Chem. Soc.* **126**, 7736–7737 (2004).
25. Gama, C. I. *et al.* Sulfation patterns of glycosaminoglycans encode molecular recognition and activity. *Nat. Chem. Biol.* **2**, 467–473 (2006).
26. Tamura, J.-I., Neumann, K. W. & Ogawa, T. A regio- and stereoselective synthesis of 4-O-sulfated chondroitin di- and tetrasaccharides based on the strategy designed for the elongation of the repeating unit. *Bioorg. Med. Chem. Lett.* **5**, 1351–1354 (1995).
27. Tamura, J.-I., Neumann, K. W., Kurono, S. & Ogawa, T. Synthetic approach towards sulfated chondroitin di-, tri- and tetrasaccharides corresponding to the repeating unit. *Carbohydr. Res.* **305**, 43–63 (1997).
28. Tamura, J., Nakada, Y., Taniguchi, K. & Yamane, M. Synthesis of chondroitin sulfate E octasaccharide in a repeating region involving an acetamide auxiliary. *Carbohydr. Res.* **343**, 39–47 (2008).
29. Lubineau, A. & Bonnaffé, D. Access to molecular diversity in glycosaminoglycans: combinatorial synthesis of eight chondroitin sulfate disaccharides. *Eur. J. Org. Chem.* **1999**, 2523–2532 (1999).
30. Karst, N. & Jacquinet, J.-C. Chemical synthesis of the disaccharide repeating unit of shark cartilage chondroitin sulfate D, and of its methyl D-glycoside derivative. *J. Chem. Soc., Perkin Trans. 1*, 2709–2717 (2000).
31. Vibert, A., Jacquinet, J.-C. & Lopin-Bon, C. Recent advances in the chemical and enzymatic chondroitin sulfate synthesis. *J. Carbohydr. Chem.* **30**, 393–414 (2011).
32. Bedini, E. *et al.* Semi-synthesis of unusual chondroitin sulfate polysaccharides containing GlcA(3-O-sulfate) or GlcA(2,3-di-O-sulfate) units. *Chemistry* **18**, 2123–2130 (2012).
33. Bedini, E. & Parrilli, M. Synthetic and semi-synthetic chondroitin sulfate oligosaccharides, polysaccharides, and glycomimetics. *Carbohydr. Res.* **356**, 75–85 (2012).
34. Karst, N. & Jacquinet, J.-C. Stereocontrolled total syntheses of shark cartilage chondroitin sulfate D-related tetra- and hexasaccharide methyl glycosides. *Eur. J. Org. Chem.* **2002**, 815–825 (2002).
35. Tamura, J. *et al.* Synthesis and interaction with midkine of biotinylated chondroitin sulfate tetrasaccharides. *Bioorg. Med. Chem. Lett.* **22**, 1371–1374 (2012).
36. Despras, G. *et al.* Toward libraries of biotinylated chondroitin sulfate analogues: from synthesis to *in vivo* studies. *Chem. - Eur. J.* **19**, 531–540 (2013).
37. Orgueira, H. A. *et al.* Modular synthesis of heparin oligosaccharides. *Chemistry* **9**, 140–169 (2003).
38. Karst, N. A. & Linhardt, R. J. Recent chemical and enzymatic approaches to the synthesis of glycosaminoglycan oligosaccharides. *Curr. Med. Chem.* **10**, 1993–2031 (2003).
39. Litjens, R. E., den Heeten, R., Timmer, M. S., Overkleeft, H. S. & van der Marel, G. A. An expedient synthesis of the repeating unit of the acidic polysaccharide of the bacteriolytic complex of lysoamidase. *Chemistry* **11**, 1010–1016 (2005).
40. Yeung, B. K. S., Chong, P. Y. C. & Petillo, P. A. Synthesis of glycosaminoglycans. *J. Carbohydr. Chem.* **21**, 799–865 (2002).
41. Coutant, C. & Jacquinet, J.-C. 2-Deoxy-2-trichloroacetamido-D-glucopyranose derivatives in oligosaccharide synthesis: from hyaluronic acid to chondroitin 4-sulfate trisaccharides. *J. Chem. Soc., Perkin Trans. 1*, 1573–1581 (1995).
42. Hada, N., Sonoda, Y. & Takeda, T. Synthesis of a novel glycosphingolipid from the millipede, *Parafontaria laminata armigera*, and the assembly of its carbohydrate moiety into multivalent structures. *Carbohydr. Res.* **341**, 1341–1352 (2006).
43. Ohlin, M., Johnsson, R. & Ellervik, U. Regioselective reductive openings of 4,6-benzylidene acetals: synthetic and mechanistic aspects. *Carbohydr. Res.* **346**, 1358–1370 (2011).
44. Tani, S., Sawadi, S., Kojima, M., Akai, S. & Sato, K.-I. A novel method for regioselective ring-opening reduction of 4,6-O-benzylidene hexopyranoside derivatives using CoCl₂ and BH₃-THF. *Tetrahedron Lett.* **48**, 3103–3104 (2007).
45. Blatter, G. & Jacquinet, J. C. The use of 2-deoxy-2-trichloroacetamido-D-glucopyranose derivatives in syntheses of hyaluronic acid-related tetra-, hexa-, and octa-saccharides having a methyl beta-D-glucopyranosiduronic acid at the reducing end. *Carbohydr. Res.* **288**, 109–125 (1996).
46. Lopin, C. & Jacquinet, J. C. From polymer to size-defined oligomers: an expeditious route for the preparation of chondroitin oligosaccharides. *Angew. Chem. Int. Ed. Engl.* **45**, 2574–2578 (2006).
47. Pilgrim, W. & Murphy, P. V. α -glycosphingolipids via chelation-induced anomerization of O- and S-glucuronic and galacturonic acid derivatives. *Org. Lett.* **11**, 939–942 (2009).
48. Banaag, A. R. & Tius, M. A. Design of chiral auxiliaries for the allene ether Nazarov cyclization. *J. Am. Chem. Soc.* **129**, 5328–5329 (2007).
49. Lemieux, R. U. & Ratcliffe, R. M. The azidonitration of tri-O-acetyl-D-galactal. *Can. J. Chem.* **57**, 1244–1251 (1979).
50. Sakagami, M. & Hamana, H. A selective ring opening reaction of 4,6-O-benzylidene acetals in carbohydrates using trialkylsilane derivatives. *Tetrahedron Lett.* **41**, 5547–5551 (2000).
51. Lucas, H. *et al.* Syntheses of heparin-like pentamers containing “opened” uronic acid moieties. *Tetrahedron* **46**, 8207–8228 (1990).
52. Sugahara, K. *et al.* Structural studies on the chondroitinase ABC-resistant sulfated tetrasaccharides isolated from various chondroitin sulfate isomers. *Carbohydr. Res.* **255**, 145–163 (1994).
53. Sugahara, K. *et al.* Chondroitinase ABC-resistant sulfated trisaccharides isolated from digests of chondroitin/dermatan sulfate chains. *Carbohydr. Res.* **255**, 165–182 (1994).
54. Gargiulo, V., Lanzetta, R., Parrilli, M. & De Castro, C. Structural analysis of chondroitin sulfate from *Scyliorhinus canicula*: a useful source of this polysaccharide. *Glycobiology* **19**, 1485–1491 (2009).
55. Akatsu, C. *et al.* Dermatan sulfate epimerase 2 is the predominant isozyme in the formation of the chondroitin sulfate/dermatan sulfate hybrid structure in postnatal developing mouse brain. *Glycobiology* **21**, 565–574 (2011).
56. Levenson, A. S. & Jordan, V. C. MCF-7: the first hormone-responsive breast cancer cell line. *Cancer Res.* **57**, 3071–3078 (1997).
57. Weisz, A. *et al.* Molecular identification of ER α -positive breast cancer cells by the expression profile of an intrinsic set of estrogen regulated genes. *J. Cell. Physiol.* **200**, 440–450 (2004).
58. Koboldt, D. *et al.* Comprehensive molecular portraits of human breast tumours. *Nature* **490**, 61–70 (2012).

59. Osborne, C. K., Hobbs, K. & Clark, G. M. Effect of estrogens and antiestrogens on growth of human breast cancer cells in athymic nude mice. *Cancer Res.* **45**, 584–590 (1985).
60. Neve, R. M. *et al.* A collection of breast cancer cell lines for the study of functionally distinct cancer subtypes. *Cancer Cell* **10**, 515–527 (2006).
61. Holliday, D. L. & Speirs, V. Choosing the right cell line for breast cancer research. *Breast Cancer Res.* **13**, 215 (2011).
62. Fulford, L. G. *et al.* Basal-like grade III invasive ductal carcinoma of the breast: patterns of metastasis and long-term survival. *Breast Cancer Res.* **9**, R4 (2007).
63. Carey, L. A. *et al.* The triple negative paradox: primary tumor chemosensitivity of breast cancer subtypes. *Clin. Cancer Res.* **13**, 2329–2334 (2007).
64. O’Toole, S. A. *et al.* Therapeutic targets in triple negative breast cancer. *J. Clin. Pathol.* **66**, 530–542 (2013).
65. Hsu, C.-H., Hung, S.-C., Wu, C.-Y. & Wong, C.-H. Toward automated oligosaccharide synthesis. *Angew. Chem. Int. Ed.* **50**, 11872–11923 (2011).

Acknowledgements

The authors thank the National University of Singapore (NUS) (ARF: R-143-000-554-112) for the financial support and NUS Graduate School for Integrative Sciences & Engineering for a Ph.D. scholarship (to Z.W.P.).

Author Contributions

Z.W.P. synthesized and characterized the CS disaccharides with the assistance of C.H.G., E.J.L. and Z.W.P. conducted the MTS and apoptosis assays with the assistance of S.G., Z.W.P., G.W.Y. and Y.L. analyzed the results and wrote the manuscript.

Additional Information

Supplementary information accompanies this paper at <http://www.nature.com/srep>

Competing financial interests: The authors declare no competing financial interests.

How to cite this article: Poh, Z.W. *et al.* Divergent Synthesis of Chondroitin Sulfate Disaccharides and Identification of Sulfate Motifs that Inhibit Triple Negative Breast Cancer. *Sci. Rep.* **5**, 14355; doi: 10.1038/srep14355 (2015).



This work is licensed under a Creative Commons Attribution 4.0 International License. The images or other third party material in this article are included in the article’s Creative Commons license, unless indicated otherwise in the credit line; if the material is not included under the Creative Commons license, users will need to obtain permission from the license holder to reproduce the material. To view a copy of this license, visit <http://creativecommons.org/licenses/by/4.0/>