

# Comparative study of photoplethysmographic waveforms with application of antihypertensive medication in hypertensive patients

Yanchun Hu MD<sup>1</sup>  | Anming Hu<sup>2</sup> | Shenju Song BD<sup>3</sup>

<sup>1</sup>Department of Orthopaedics, The Fifth People's Hospital of Jinan, Jinan, China

<sup>2</sup>Taishan College, Shandong University, Jinan, China

<sup>3</sup>Department of Nursing, The Fifth People's Hospital of Jinan, Jinan, China

## Correspondence

Yanchun Hu, Department of Orthopaedics, The Fifth People's Hospital of Jinan, No.24297 of Jingshi road, Jinan 250022, China.

Email: [huyanchun@21cn.com](mailto:huyanchun@21cn.com)

## Funding information

The authors received no financial support for the research, authorship, and publication of this article.

## Abstract

**Background:** Multiple studies have been published using a pulse oximeter's photoplethysmographic (PPG) capability to detect tissue perfusion. However, the origin of the PPG signal is still debatable.

**Aim:** A comparative study was performed of PPG waveforms in hypertensive patients before and after treatment with antihypertensive medication. The aim of this study was to observe the changes of PPG waveforms before and after lowering blood pressure in hypertensive patients and then to detect the relationship between blood pressure and PPG waveforms.

**Methods:** The PPG waveforms of 60 patients with hypertension were collected. After administration of the antihypertensive medication nitroglycerin, PPG waveforms were collected again. The changes of the T3 (time3): This phase occurred between Marker 3 and Marker 4 (this phase occurs mid-diastolic) angle, before and after the antihypertensive medication treatment, were compared. The statistical analyses of two related groups were performed using the Paired t-test.

**Results:** The blood perfusion waveforms of hypertensive patients before and after antihypertensive medication administration were differently indicated with the tilt angle T3. The slope angle of the T3 phase waveform increased significantly when the blood pressure dropped to normal ( $-41.9 \pm 16.2^\circ$  vs.  $-25.6 \pm 21.9^\circ$ ,  $p < .0001$ ), and the tilt angle of some patients was similar to that of adults with normal blood pressure.

**Conclusion:** In patients with hypertension, the tilt angle of the PPG waveform in the T3 phase increased significantly after administration of the antihypertensive medication nitroglycerin. It is worth to conduct deeper research about the relationship between hypertension and the blood perfusion of microcirculation in the diastolic period.

## KEYWORDS

cardiovascular, hypertension, microvascular, photoplethysmography(PPG)

This is an open access article under the terms of the Creative Commons Attribution-NonCommercial License, which permits use, distribution and reproduction in any medium, provided the original work is properly cited and is not used for commercial purposes.

© 2022 The Authors. *Annals of Noninvasive Electrocardiology* published by Wiley Periodicals LLC.

## 1 | INTRODUCTION

It is generally accepted that photoplethysmography (PPG) components can provide valuable information about the cardiovascular system, but the origin of the PPG signal is still debatable. The classic theory assumes that the PPG waveform stems from variations of blood volume in pulsating arteries (Volkov et al., 2017).

The working principle of PPG is that the absorption of light by arterial blood changes with the pulse of the artery. The pulse oximeter irradiates the fingertip vertically with a specific intensity of monochromatic light. When the arteries and blood vessels in the transparent area pulsate, the absorption of light by skin, muscle, bone, and other tissues is constant. However, as the arteries pulsate, the microcirculation perfusion changes, and the blood absorption of light changes accordingly (Photoplethysmography). The rise and fall in the PPG waveforms originate from the change in microcirculation perfusion, which is the theoretical basis of our study and the basis for further analysis (Shelley, 2007).

This study aimed to investigate differences in the characteristics of PPG waveforms. In younger patients, based on a previous study, there were two peaks (first and second peaks) and a dicrotic notch in each PPG waveform (Allen & Murray, 2003). As patient age increased, the depth of the PPG dicrotic notch became shallower (Allen & Murray, 2003). In hypertensive patients, no pronounced dicrotic notch was observed and they did not show a true +c elevation; instead, a-c descent was observed (Hu, 2015). In order to further study, the occurrence and development of hypertension, the changes of PPG waveforms in patients with hypertension before and after antihypertensive medication treatment were observed. In clinical therapy, there were always some occasions, which needs to reduce blood pressure in a short period, including preparations for surgery, a sudden increase of blood pressure during the process of treatment and discomfort of hypertension patients. Therefore, we aimed to find if the PPG waveform could be clinical information, which indicates the successful reduction of blood pressure after antihypertensive medication treatment.

Our previous studies have shown that the T3 angle of PPG in hypertensive patients is significantly different from that in normal subjects (Hu, 2015), which suggests that diastolic microcirculation perfusion is reduced. Some researchers think this is related to vascular sclerosis; however, the fact is not clearly understood now. This study compares the changes of T3 angle of PPG in hypertension patients after applying nitroglycerin to rapidly reduce blood pressure in a short period of time. Our study indicated that diastolic microcirculation perfusion changes were related to the blood pressure of hypertensive patients; T3 angle of PPG reduction in hypertensive patients was not related to vascular sclerosis and nitroglycerin targets the microcirculation, which were closely related to the occurrence and development of hypertension.

## 2 | MATERIALS AND METHODS

### 2.1 | Study design

When the blood pressure measurement reaches the standard value, we can take a screenshot to capture and analyze PPG waveform.

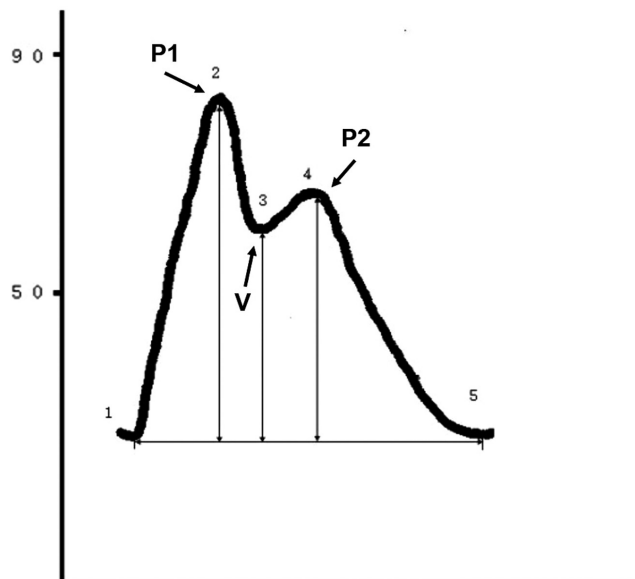

**FIGURE 1** Schematic diagram of PPG waveform. Five markers were used to locate the necessary points of the signal. Marker 1 is the first foot of the PPG waveform, marker 2 is the first peak of the waveform, marker 3 is the valley, marker 4 is the second peak, and marker 5 is the second foot of the waveform; P1 and P2 indicate two positive waves respectively, V indicates the negative wave. The angle of PPG waveform T3 is defined as the angle between marker 3 and marker 4 points

Two well-trained technicians who were blinded to patients' characteristics used the measuring ruler to accomplish signal handled/ plotted and analyzed the PPG graph. Any disagreement in the measurements was resolved by their consensus or a third investigator. To detect the blood pressure by Mindray monitor, and cuff blood pressure detection is performed every 10 minutes. PPG waveforms were collected by a Mindray monitor (Multi-parameter Medical Monitor for hospital ICU mindray). The hypertension patient was at a room temperature of 24–27°C and was lying in bed quietly while nitroglycerin, the antihypertensive medication, was administered intravenously. The intravenous nitroglycerin rate was 20–100 µg/min, which administered dose ranged from 0.5–5 mg. And the blood pressure was measured by an electronic blood pressure monitor with cuff. The duration of nitroglycerin infusion was around 10 to 60 minutes until blood pressure dropped to normal (systolic blood pressure less than 140 mmHg and diastolic blood pressure less than 90 mmHg). Then the patient's PPG images began to be captured. Images were collected after five continuous and stable PPG images were parallel to the baseline, and the intermediate waveform of five waveforms was taken as the acquisition target.

(For younger subjects, there were two positive waves (P1 and P2) and one negative wave (V), as shown in Figure 1. (Figure 1. Example of PPG waveform recognition.) The minimum and maximum threshold (P1 and P2) and valley (V) values were used as markers for signal analysis and comparison. Five markers were used to locate the necessary points of the signal. Marker 1 was the first foot of the PPG waveform, Marker 2 was the first peak of the waveform, Marker 3 was the valley, Marker 4 was the second peak, and Marker 5 was the

second foot of the waveform (Hu, 2015). According to the proportion of normal adult T1, 2, 3, 4 in a cardiac cycle, Marker 3 characterizes the location of the midpoint from Marker 1 to Marker 5, and Marker 4 characterizes the location of the midpoint from Marker 2 to Marker 5. In this way, T3 is roughly the same as the T3 of a normal adult in a cardiac cycle.

For young, healthy subjects, each PPG waveform involved four major phases.

+a elevation: This phase occurred between Marker 1 and Marker 2. This phase (T1) lasted  $0.166 \pm 0.023$  seconds.

-b descent: This phase occurred between Marker 2 and Marker 3. This phase (T2) lasted  $0.197 \pm 0.039$  seconds.

+c elevation: This phase occurred between Marker 3 and Marker 4. This phase (T3) lasted  $0.183 \pm 0.050$  seconds.

-d descent: This phase occurred between Marker 4 and Marker 5. This phase (T4) lasted  $0.290 \pm 0.039$  seconds.(4).

The second peak of hypertensive patients is low or even disappear, so the onset and termination point of T3 is not easy to visualize. Therefore, Marker 3 characterizes the location of the midpoint from Marker 1 to Marker 5, and Marker 4 characterizes the location of the midpoint from Marker 2 to Marker 5. The angle between the line between Marker 3 and Marker 4 points and the baseline is taken as the angle of PPG waveform T3. [Figure 1](#).

The comparison of the changes in PPG waveform T3 and the tilt angle in patients with hypertension before and after the application of nitroglycerin can be used as the index of microcirculation perfusion in the diastolic phase before and after application of antihypertensive medications.

Study population and sample size.

From December 2018 to May 2020, 27 male and 33 female patients with hypertension were studied, aged 28–86 years, with an average age of  $60.8 \pm 8.6$  years (mean  $\pm$  standard deviation). These patients had a systolic blood pressure greater than 140 mmHg or a diastolic blood pressure greater than 90 mmHg as the collection standard. The average heart rate was 55–95 beats/min. The heart rate fluctuation was less than 10% before and after the application of antihypertensive medication. If the patient had an infectious disease or cancer, the patient was excluded. After the physician's consultation, the application of nitroglycerin to lower blood pressure was determined. Patients with primary hypertension can be enrolled in the study if other conditions are suitable. We chose nitroglycerin as the application of antihypertensive medication because nitroglycerin is not used for a long time, but a one-time application, and the effect of nitroglycerin is short and rapid. Nitroglycerin acts on arterioles and venules. After intravenous injection of nitroglycerin, it has a small change in the elastic modulus of aorta in a short time. It can be used to judge and discuss the relationship between changes in PPG waveforms and vascular sclerosis. Since this study goal was not to summarize treatment of hypertension, previous treatment and subsequent treatment of hypertension were not investigated. As long as the patient was diagnosed with primary hypertension, and the blood pressure could drop to normal range after the application of nitroglycerin, the patient was involved in the study population. After

reducing blood pressure by nitroglycerin in a short period, the PPG waveform was collected.

This study did not involve prospective evaluation and laboratory animals. To make every participated patient get adequate and reasonable treatment, the researcher did not participate in the formulation of the treatment plan and only collect the data and images needed for the research after the treatment plan was fully implemented. All participated patients in the study have been informed about this study and signed informed consent. This study has been approved by the ethics committee of our hospital.

## 2.2 | Statistical analysis

All data were shown as mean  $\pm$  standard deviation (SD). The comparison of two related groups was performed using Paired t-test, and the statistical significance was defined as  $p < 0.05$  according to  $\alpha = 0.05$  level. All statistical analyses were performed with GraphPad Prism Software version 8.2.1.

## 3 | RESULTS

There are significant differences in blood flow before and after the drug performance at the event. When the blood pressure drops to normal, the perspective of the T3 phase is clear, and the perspective of the tourists is similar to the normal situation, and the tilt angle of some patients was similar to that of adults with normal blood pressure. Among the bright audiences, after the medicinal particle screen, the angle of the PPG screen in the T3 phase has increased significantly. It is worth to conduct deeper research about the relationship between hypertension and the blood perfusion of microcirculation in the diastolic period.

The standard deviation (SD) measures the amount of variability, or dispersion, from the individual data values to the mean, while the standard error of the mean (SEM) measures how far the sample mean (average) of the data is likely to be from the true population mean. The SEM is always smaller than the SD. Patients in this study were  $60.71 \pm 8.59$  years old, PPG images were collected after five continuous and stable PPG images were parallel to the baseline and the T3 tilt angles were measured and analyzed. [Figure 2](#) showed the waveform examples of patients with hypertension, and [Figure 3](#) showed the waveform examples after the application of nitroglycerin. [Figure 4](#) describes the Statistical graph of T3 phase tilt angle before and after the application of nitroglycerin. [Figure 5](#) briefly describes the tension switch model for arteriovenous anastomoses. The application of nitroglycerin did show a significantly antihypertensive function in both systolic blood pressure ( $163.8 \pm 17.1$  mmHg vs.  $122.0 \pm 12.1$  mmHg,  $p < .0001$ ) and diastolic blood pressure ( $92.7 \pm 11.8$  mmHg vs.  $74.0 \pm 9.6$  mmHg,  $p < .0001$ ) as shown in [Figure 4A](#) and [4B5](#). The heart rates of patients increased significantly after the application of nitroglycerin ( $77.3 \pm 11.0$  vs.  $75.9 \pm 10.3$ ,  $p = .023$ ) ([Figure 4C](#)). The change of the T3 phase tilt angle before and after the application of

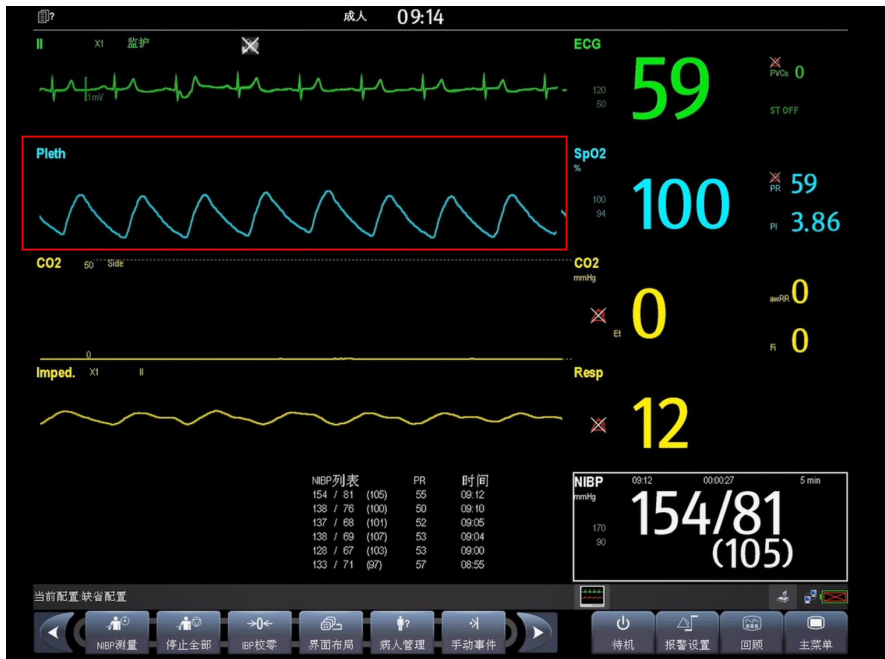

FIGURE 2 PPG waveform examples of patients with hypertension

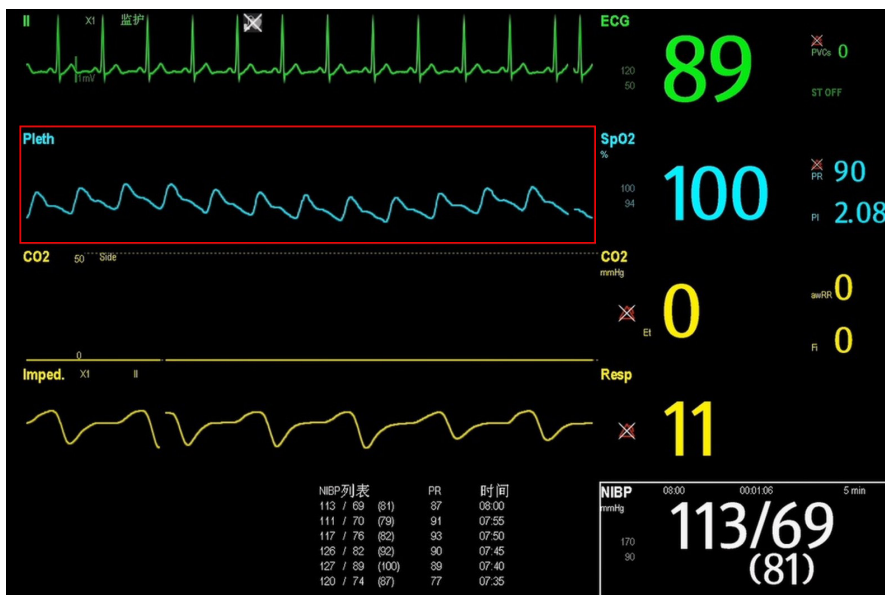

FIGURE 3 PPG waveform examples of patients with hypertension after the application of nitroglycerin

the antihypertensive medication was obvious. After the application of nitroglycerin, the inclination angle of T3 increased significantly ( $-41.9 \pm 16.2^\circ$  vs.  $-25.6 \pm 21.9^\circ$ ,  $p < .0001$ ) (Figure 4D). In some patients, the inclination angle of T3 recovered to a positive value, close to healthy adults without hypertension. There was a significant increase in the T3 tilt angle after the application of the antihypertensive medication compared with before, which mean value was increased 39% by administration of nitroglycerin. These results suggested that the diastolic microcirculation perfusion was increased significantly by nitroglycerin.

In patients with hypertension, the microcirculation blood perfusion is significantly different in the diastolic period before and after the application of the vasoactive drug nitroglycerin. Compared with healthy adults, the perfusion of diastolic microcirculation in patients with hypertension should be significantly reduced. Through

medication intervention, the peripheral microcirculation perfusion of finger in the diastolic phase of patients with hypertension was significantly improved.

## 4 | DISCUSSION

The difference in PPG waveforms between non-hypertensive young and old patients is the T3 tilt angle. The inclination angle of the PPG waveform T3 in the elderly was smaller than that in the young. In patients with hypertension, the inclination angle at T3 was smaller, even negative, and the second peak disappeared (Hu, 2015). However, this study showed that after a short period of antihypertensive medication treatment (when blood pressure returned to normal value), T3 tilt angle increased, and some PPG waveforms were

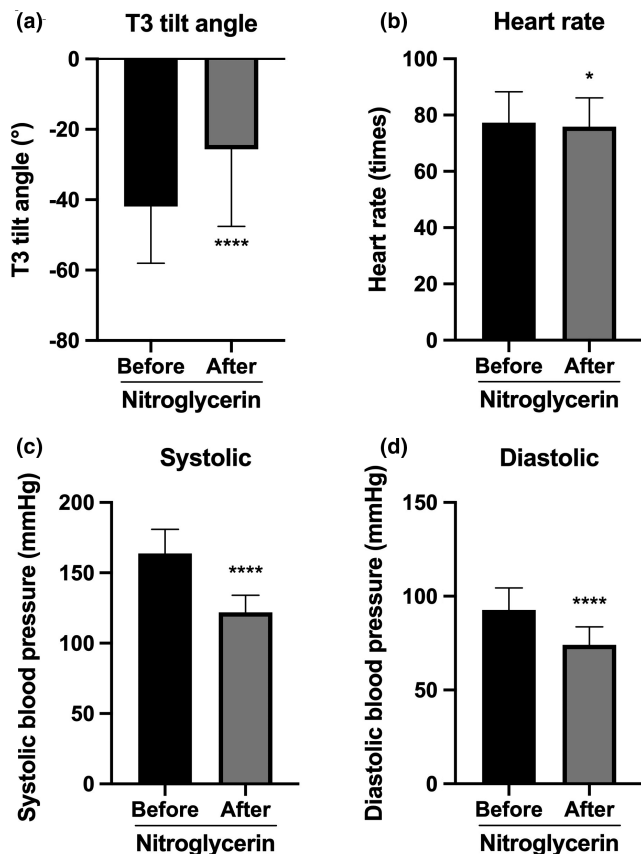

FIGURE 4 Statistical graph of systolic blood pressure (a), diastolic blood pressure (b), heart rate (c), and T3 phase tilt angle (d) before and after the application of nitroglycerin. All data are presented as mean ± SD. \* $p < .05$ , \*\*\*\* $p < .0001$

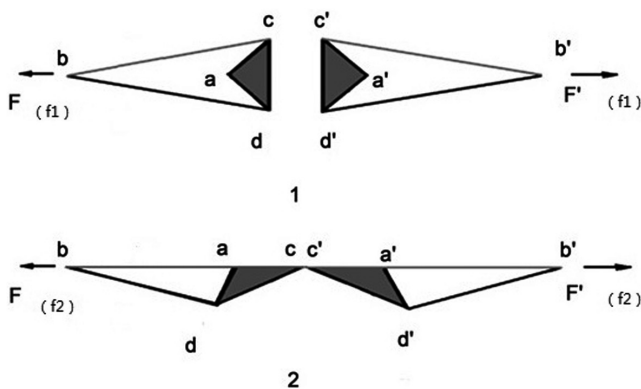

FIGURE 5 The tension switch model for arteriovenous anastomoses

similar to those of normal adults. Therefore, it can be considered that the occurrence of hypertension and drug-induced normalized blood pressure are closely related to the T3 tilt angle of PPG waveform.

There is a second peak in the PPG waveform of young people not diagnosed with hypertension. The reason why this second peak appears has always been controversial (Allen, 2007; Chan et al., 2011). Some people think that the second peak of PPG in healthy patients is due to the backward wave. Others believe that the disappearance of

the second wave peak in patients with hypertension is caused by arteriosclerosis of the great arteries. They believe that the pulse wave velocity of arteriosclerosis increases, so that the first and second wave peaks overlap, ensuring the second peak does not appear. This explanation raises multiple questions. When heart rate increases (for example after exercise), if the disappearance of the second wave peak in patients with hypertension is caused by the overlapping of the first and second wave peaks, the waveform overlap of the first and second wave peaks after the change of heart rate will also be incorrect, causing the waveform to be irregular. However, the PPG waveforms in patients with hypertension after a heart rate change was still very regular. Because of the fluctuation of microcirculation perfusion volume displayed by the PPG waveform, it is determined to not be the direct manifestation of mechanical waves at the end of limbs. This study demonstrated that after antihypertensive medication treatment, the inclination angle of T3 increased, and in some patients, the second peak (+c elevation) even appeared. A clear conclusion of this experiment is that the disappearance of the second wave peak in patients with hypertension is not caused by arteriosclerosis of the great arteries because arteriosclerosis cannot be improved in a short time.

The causes of the second peak in healthy young people, the disappearance of the second peak in patients with hypertension, and the reasons for the recovery of the second peak in hypertensive patients after antihypertensive medication administration should be further discussed.

The human cardiovascular system includes the heart and peripheral blood vessels. The heart contracts regularly, providing kinetic energy for blood flow. The capillaries are a strongly bifurcated network of small vessels. Cardiovascular bifurcations have a significant influence on the distribution of the blood cells and blood flow behavior (Wang et al., 2016). The number of vessels in the capillary system is significantly larger than in the arterial and venous systems. As a consequence, the total cross-section in the capillary system is about 1000 times larger than in the arterial and venous systems. When the blood flows out of the capillaries into the venules, the total cross-sectional area gradually becomes smaller (Kozlov & Banin, 1975). In this way, the capillary network forms the pipeline structure, which has an enlarged total cross-sectional area in the midsection and a lesser total cross-sectional area at each end (Hu, 2013). Due to small elastic modulus and larger cross-sectional areas, the capillaries behave as a “windkessel,” which can cushion the pulsations generated by the heart (Mei et al., 2018). The structural characteristics of the capillary network allow the microcirculation perfusion to increase or decrease with the diastole and contraction of the heart. And the first peak in the PPG waveform of healthy young people is a result of the increase of microcirculation perfusion. The increase in peripheral microcirculation perfusion in the capillaries causes a first peak in the PPG waveform of healthy young people.

In the systolic phase, when blood flows out of the heart, the velocity of flow is about 0.2 M/s while the velocity of flow in the capillary network decreases to less than 0.01 M/s. The flow rate of

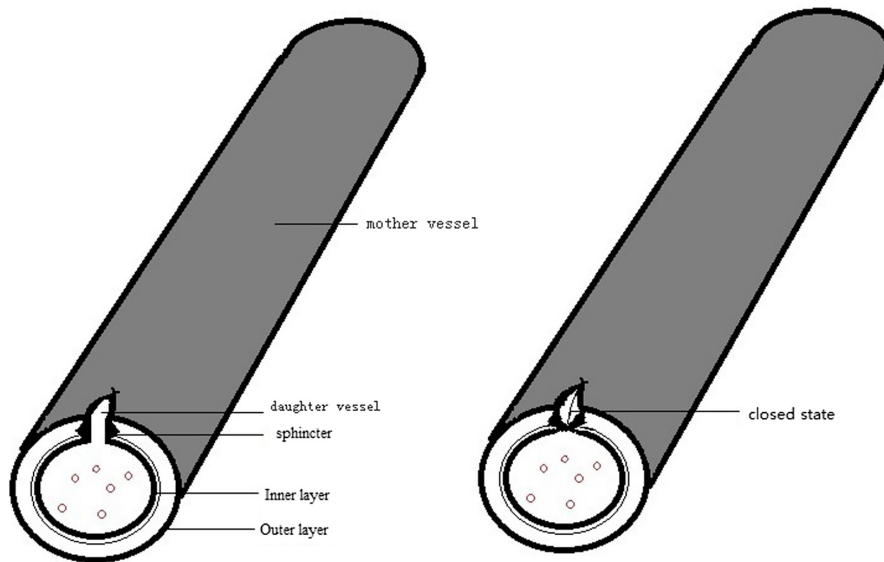

**FIGURE 6** When the inner pressure of mother vessel is less than 90 mmHg, the tensile force of the outer layer decreases, the elastic modulus of the inner layer is small, and it still maintains a certain tensile force. The lip-like structure turns and is open

blood cells decreases significantly (Hudetz, 1997). Head loss is the loss of mechanical energy of unit mass fluid in the process of movement. The kinetic energy of the blood flow generated by the contraction of the heart is ultimately converted into heat due to friction (OsmanAkan, 2007). The decrease of blood flow rate in the capillary network indicates that the friction in the capillary network is very large and this decrease in velocity of flow is favorable for material exchange (Huang et al., 2010). The blood flow in capillaries is continuous, but not uniform, as is demonstrated by the second peak of the PPG blood volume appearing at the mid-diastolic phase. If more blood flowed into the capillary network in the mid-diastolic phase, the red blood cell velocity would increase. However, a flow rate that is too high is not beneficial for material exchange.

There is a shortcut that can bypass the capillaries by shunting blood from the arteries to the veins. This shortcut is an Arteriovenous Anastomosis (AVA), which is defined as a normal vascular channel connecting the arterial and venous sides of circulation (Sherman, 1963). AVAs have a thick wall that is composed of variable numbers of epithelioid and modified smooth muscle cells. In the arterial segment, smooth muscle cells are spindle-shaped (either elongated or short), with a few branches, and are arranged circularly or diagonally with respect to the vessel's long axis. The smooth muscle forming the sphincter may permit local regulation of blood flow (Law, 1959; Takahashi, 1994). It is suspected that the formation of the second peak in the PPG waveform in healthy patients is due to the sudden opening of an AVA during diastole. If this is true, the AVA will open during diastole (blood pressure less than 90 mmHg). The AVA should close during systole (blood pressure greater than or equal to 90 mmHg). Otherwise, it is not conducive to capillary perfusion. Before this possibility is discussed, a kind of lip-type structure will be examined (Hu & September, 2018).

Figure 5 demonstrates a tension switch model with different elastic modulus materials. The two valves are symmetrical, as is the valve channel between cd and c'd'. The fixed axis is a, a'. Triangular

acd and a'c'd' are valves and can rotate around the a, a' fixed axis. The lines bc and b'c' are rubber rope, and bd and b'd' are cotton rope. The cotton ropes are longer than the rubber rope if they are not stressed. The elastic modulus of cotton rope is larger than that of rubber rope. There is a certain elastic  $F(f_1)$  on b and b' that makes the length ac equal ad and bc equal bd. The cd and c'd' parallel channels are in the open state. The b and b' points in the opposite direction were respectively applied with forces  $F(f_1)$  and  $F(f_2)$ , where  $f_1$  is less than  $f_2$ . Due to the elastic modulus of cotton rope being larger than that of rubber rope, under the action of the tension, the acd valve showed a clockwise rotation, while the a'c'd' valve showed a counterclockwise rotation resulting in a closed channel. When F and F' decreased, the channel was opened up with the counterclockwise rotation of acd and the clockwise rotation of a'c'd'.

In an AVA, the vertical arrangement of spindle-shaped smooth muscle cells in the mother arterial segment can mimic the acd valve, which controls the opening of the AVA. The endodermis can mimic bc (the rubber rope) and the lateral arrangement of smooth muscle cells can mimic bd (the cotton rope). In diastole, a pressure less than 90 mmHg can mimic  $f_1$ , causing the AVA to open. In systole, a pressure greater than or equal to 90 mmHg can mimic  $f_2$ , causing the AVA to close. The structural characteristics of AVA and arterioles provide possibility for sudden opening of an AVA during diastole. Histologically, the AVA are low-resistance vessels that are parallel to the capillary network. They form low-resistance channels through which the high-capacity venous bed can be rapidly perfused. If the AVA opens in diastole, the blood flow rate into the capillaries is reduced. A lower blood flow rate in the capillaries increases material exchange.

In fact, the systolic blood pressure is lower than 90 mmHg in shock, and when successful treatment of the underlying cause is not obtained, there will be a decompensated stage performance, vasoactive substances are released, and small arteries are dilated, then AVAs will open. This phenomenon is characteristic of changes in

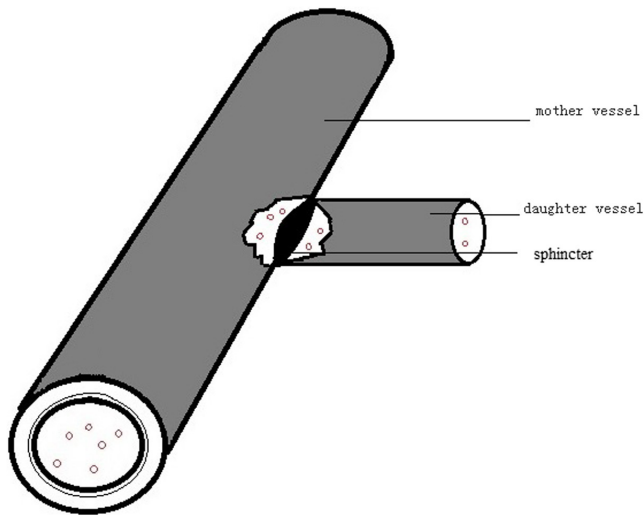

**FIGURE 7** When the inner pressure of mother vessel is greater than 95 mmHg, the elastic modulus of the outer layer is greater than that of the inner layer, and the lip-like structure turns to the closed state

microcirculation during shock (Balestrazzi, 1950; Pries et al., 1994). A lower systolic blood pressure means less smooth muscle tension in the arterioles. However, patients with hypotension shock will not display the regular PPG waveforms of double-peak waveforms. In hypertensive patients, high blood pressure means increased smooth muscle tension; therefore, PPG waveforms do not produce two peaks.

In blood circulation, the inner diameter of capillaries is only about 6 microns, so that red blood cells need to transform to pass, which indicates that the frictional resistance in the capillary network is very high. According to the basic flow equation, the medical researchers believe that arterioles are the main contributor to peripheral resistance rather than the capillary network and diastolic arteriole smooth muscle can indeed lower blood pressure. But the basic flow equation is not same accurate as Ohm's law, especially in complex series and parallel pipelines, such as human microcirculation (Hu, 2013). In this study, nitroglycerin was used as the antihypertensive medication. It has been used medically as a potent vasodilator, is often used in conditions of cardiovascular ischemia, and acts through the liberation of nitric oxide (Agvald et al., 2002). Nitroglycerin can reduce the elastic modulus of smooth muscle. This study demonstrates that the administration of nitroglycerin can recover the inclination angle of the PPG waveform T3, and improves perfusion during the mid-diastolic phase, while blood pressure returns to normal. This shows that the change of the inclination angle in the PPG waveform T3 plays an important role in the occurrence and treatment of hypertension.

Given that the inclination angle of the PPG waveform T3 provided such useful information, serious further analysis should be given to it. The histologic changes and dysfunction of AVAs should also be intensively studied.

In the study of microcirculation, with the rapid development of medical technology, intuitive image data of microcirculation could

be obtained more frequently. Additional analysis of hemodynamics will continue to be helpful in understanding microcirculation and hypertension.

The structure diagram added at AVA in Figure 6 and Figure 7. The focus includes mother ship and daughter ship. The connection between the mother ship and the daughter ship is the structure of the simulated AVA entrance. At the lip, there is a thickened area of M fibers arranged in the direction of other ships, forming a lip-like longitudinal structure. Because the thickened area is a fibrous tissue and the direction of the elastic modulus, the lip-like structure will not be pulled too far from the tangential direction when subjected to the tangential pull of the wall tube. The inner layer and outer layer have different elastic modulus. Lip-like structure can appear when the pressure in the mother blood vessel changes, opening the characteristic. When the intravascular pressure of the other blood vessels reaches 90 mmHg, the elastic modulus of the outer fibers is greater than 90 mmHg, and the lips turn to the closed state. As shown in the right picture of Figure 6. When the internal pressure of the mother's blood vessel is less than 90 mmHg, the outer fiber tension will decrease, the inner elastic modulus will be small, and a certain tension will be maintained, and the lip-like structure will be in an open state. As shown in Figure 6.

Conclusion: Our study demonstrated the changes in the tilt angle of the PPG waveform in T3 phase in patients with hypertension treated with nitroglycerin. The tilt angle increased significantly after the administration of the antihypertensive treatment. These results suggest that further research about the relationship between hypertension and the blood perfusion of microcirculation in the diastolic period need to be conducted and it may provide a new direction for hypertension detection.

#### ACKNOWLEDGMENTS

Not applicable.

#### CONFLICT OF INTERESTS

All of the authors had no any personal, financial, commercial, or academic conflicts of interest separately.

#### AUTHOR CONTRIBUTIONS

Conception and design of the research: Hu YC, Hu AM. Acquisition of data: Hu YC, Hu AM, Song SJ. Analysis and interpretation of the data: Hu YC, Hu AM, Song SJ. Statistical analysis: Hu YC, Hu AM, Song SJ. Obtaining financing: None. Writing of the manuscript: Hu YC, Hu AM. Critical revision of the manuscript for intellectual content: Hu YC.

#### CONSENT FOR PUBLICATION

All authors final approval of the version to be published.

#### ETHICAL STATEMENT

This study was approved by the ethics committee of The Fifth People's Hospital of Jinan, and informed consent was obtained from all participants.

## DATA AVAILABILITY STATEMENT

The datasets used or analyzed during the current study are available from the corresponding author on reasonable request.

## ORCID

Yanchun Hu  <https://orcid.org/0000-0002-3937-681X>

## REFERENCES

- Agvald, P., Adding, L. C., Artlich, A., Persson, M. G., & Gustafsson, L. E. (2002). Mechanisms of nitric oxide generation from nitroglycerin and endogenous sources during hypoxia in vivo. *British Journal of Pharmacology*, 135(2), 373–382. <https://doi.org/10.1038/sj.bjp.0704489>
- Allen, J. (2007). Photoplethysmography and its application in clinical physiological measurement. *Physiological Measurement*, 28, R1–39. <https://doi.org/10.1088/0967-3334/28/3/R01>
- Allen, J., & Murray, A. (2003). Age-related changes in the characteristics of the photoplethysmographic pulse shape at various body sites. *Physiological Measurement*, 24(2), pp. 297–307. <https://doi.org/10.1088/0967-3334/24/2/306>
- Balestrazzi, N. (1950). Importance of dysfunction of the arteriovenous anastomoses in determinism of shock. *Bollettino. - Societa Italiana Biologia Sperimentale*, 26(3), 277–279.
- Chan, G. S., Middleton, P. M., & Lovell, N. H. (2011). Photoplethysmographic variability analysis in critical care—current progress and future challenges. *Annual International Conference of the IEEE Engineering in Medicine and Biology Society*, 2011, 5507–5510.
- Hu, Y. (2013). Flow resistance of vessels with an enlarged total cross-sectional area in the midsection. *Open Circulation & Vascular Journal*, 6, 9–12. <https://doi.org/10.2174/1877382601306010009>
- Hu, Y. (2015). Photoplethysmographic waveforms recorded from patients with untreated hypertension. *Clinical Medicine Research*, 4, 163–167. <https://doi.org/10.11648/j.cmr.20150405.18>
- Hu, Y. (2018). New insight into microvascular perfusion by analyzing pipe flow in a cylindrical elastic shell. *Journal of Biomedical Science and Engine*, 11(9), 247–253. <https://doi.org/10.4236/jbise.2018.119020>
- Huang, T. C., Lin, W. C., Wu, C. C., Zhang, G., & Lin, K. P. (2010). Experimental estimation of blood flow velocity through simulation of intravital microscopic imaging in micro-vessels by different image processing methods. *Microvascular Research*, 80, 477–483. <https://doi.org/10.1016/j.mvr.2010.07.007>
- Hudetz, A. G. (1997). Blood flow in the cerebral capillary network: a review emphasizing observations with intravital microscopy. *Microcirculation*, 4(2), 233–252. <https://doi.org/10.3109/10739689709146787>
- Kozlov, V. I., & Banin, V. V. (1975). Analysis of the structural parameters of the blood flow pathways in the microcirculatory system. *Arkh Anat Gistol Embriol*, 69(9), 54–62.
- Law, M. E. (1959). A study of peripheral arterio-venous anastomoses. *The Irish Journal of Medical Science*, 34(8), 333–342.
- Mei, C. C., Zhang, J., & Jing, H. X. (2018). Fluid mechanics of Windkessel effect. *Medical & Biological Engineering & Computing*, 56(8), 1357–1366. <https://doi.org/10.1007/s11517-017-1775-y>
- OsmanAkan, A. (2007) Open Channel Hydraulics. Available online 2 September 2007. <https://doi.org/10.1016/B978-075066857-6/50007-2>
- Shelley, K. H. (2007). Photoplethysmography: Beyond the calculation of arterial oxygen saturation and heart rate. *Anesthesia & Analgesia*, 105(6), S31–S36.
- Pries, A. R., Secomb, T. W., Gessner, T., Sperandio, M. B., Gross, J. F., & Gaehtgens, P. (1994). Resistance to blood flow in microvessels in vivo. *Circulation Research*, 75, 904–915. <https://doi.org/10.1161/01.RES.75.5.904>
- Sherman, J. L. Jr (1963). Normal arteriovenous anastomoses. *Medicine (Baltimore)*, 42, 247–267. <https://doi.org/10.1097/00005792-196307000-00001>
- Takahashi, A. (1994). A scanning electron microscopic study on the smooth muscle cells of the human intracranial arteries—normal and pathological. *Hokkaido Igaku Zasshi*, 69(6), 1455–1467.
- Volkov, M. V., Margaryants, N. B., Potemkin, A. V., Volynsky, M. A., Gurov, I. P., Mamontov, O. V., & Kamshilin, A. A. (2017). Video capillaroscopy clarifies mechanism of the photoplethysmographic waveform appearance. *Scientific Reports*, 7(1), <https://doi.org/10.1038/s41598-017-13552-4>
- Wang, T., Rongin, U., & Xing, Z. W. (2016) A micro-scale simulation of red blood cell passage through symmetric and asymmetric bifurcated vessels. *Scientific Reports*, 6, 20262.

**How to cite this article:** Hu, Y., Hu, A., & Song, S. (2022). Comparative study of photoplethysmographic waveforms with application of antihypertensive medication in hypertensive patients. *Annals of Noninvasive Electrocardiology*, 27, e12941. <https://doi.org/10.1111/anec.12941>