

Received: 2016.08.23
Accepted: 2016.12.09
Published: 2017.06.19

Correlations of Complete Blood Count with Alanine and Aspartate Transaminase in Chinese Subjects and Prediction Based on Back-Propagation Artificial Neural Network (BP-ANN)

Authors' Contribution:

Study Design A
Data Collection B
Statistical Analysis C
Data Interpretation D
Manuscript Preparation E
Literature Search F
Funds Collection G

CEF 1 **Jiong Yu**
CE 1 **Qiaoling Pan**
CF 1 **Jinfeng Yang**
F 1 **Chengxing Zhu**
CD 1 **Linfeng Jin**
D 1 **Guangshu Hao**
D 2 **Xiaowei Shi**
AEG 1 **Hongcui Cao**
BC 3 **Feiyan Lin**

1 The State Key Laboratory for Diagnosis and Treatment of Infectious Diseases, First Affiliated Hospital, College of Medicine, Zhejiang University; Collaborative Innovation Center for Diagnosis and Treatment of Infectious Diseases, Hangzhou, Zhejiang, P.R. China
2 Chu Kochen Honors College, Zhejiang University, Hangzhou, Zhejiang, P.R. China
3 Central Laboratory, The First Affiliated Hospital of Wenzhou Medical University, Wenzhou, Zhejiang, P.R. China

Corresponding Authors:

Hongcui Cao, e-mail: hccao@zju.edu.cn, Feiyan Lin, e-mail: singlelin@yeah.net

Source of support:

This work was supported by the National Science and Technology Major Project (No. 2012ZX10002004) and Chinese High Tech Research & Development (863) Program (No. 2013AA020102) projects of the Health Department of Zhejiang province (2014KYB100, 2015KYB114)

Background: The complete blood count (CBC) is the most common examination used to monitor overall health in clinical practice. Whether there is a relationship between CBC indexes and alanine transaminase (ALT) and aspartate aminotransferase (AST) has been unclear.





Material/Methods: In this study, 572 normal-weight and 346 overweight Chinese subjects were recruited. The relationship between CBC indexes with ALT and AST were analyzed by Pearson and Spearman correlations according to their sex, then we conducted colinearity diagnostics and multiple linear regression (MLR) analysis. A prediction model was developed by a back-propagation artificial neural network (BP-ANN).

Results: ALT was related to 4 CBC indexes in the male normal-weight group and 3 CBC indexes in the female group. In the overweight group, ALT had a similar relationship with the normal group, but there was only 1 index related with AST in the normal-weight group and male overweight groups. The ALT regression models were developed in normal-weight and overweight people, which had better correlation coefficient ($R > 0.3$). After training 1000 epochs, the BP-ANN models of ALT achieved higher correlations than MLR models in normal-weight and overweight people.

Conclusions: ALT is a more suitable index than AST for developing a regression model. ALT can be predicted by CBC indexes in normal-weight and overweight individuals based on a BP-ANN model, which was better than MLR analysis.

MeSH Keywords: **Alanine Transaminase • Aspartate Aminotransferases • Blood Cell Count • Overweight**

Full-text PDF: <http://www.medscimonit.com/abstract/index/idArt/901202>

 2224  6  2  20



Background

The complete blood count, also referred to as routine blood test and full blood count, is the most common and available test in medical practice. It can provide 16–18 indexes, including white blood cell (WBC), red blood cell (RBC), and platelet (PLT) counts, which can be used to diagnose anemia, blood loss, thrombocytopenia, acute and chronic infections, abnormalities in blood cells, allergies, leucocythemia, and other blood-related problems [1–3]. Therefore, CBC has been widely used to monitor overall health and diagnose some medical conditions.

Alanine transaminase (ALT), also known as glutamic-pyruvic transaminase, and aspartate aminotransferase (AST), also known as glutamic oxaloacetic transaminase, are important transaminase enzymes in amino acid metabolism. They are the most sensitive and widely used liver enzymes to indicate liver damage, such as that due to viral hepatitis, alcoholic fatty liver disease, and primary liver cancer [4–6]. Moreover, they are key enzymes in the liver [7] and are related to carbohydrate intake and the metabolic process that converts food into energy.

Although ALT, AST, and CBC are widely used in medical practice, they are performed in different ways: ALT and AST are measured in serum, while CBC should be measured in whole blood. Therefore, 2 different blood samples are needed and are detected in different ways to obtain blood levels of ALT, AST, and CBC indexes, which is inconvenient for people undergoing a clinical examination. The concentration values of ALT and AST in plasma can be estimated by body mass index (BMI) and triglyceride, cholesterol, high-density lipoprotein, and glucose levels by using an artificial intelligence algorithm [8]. Whether ALT and AST are correlated with CBC indexes remains unknown. If the serum levels of ALT and AST could be predicted by CBC directly, it would have important clinical significance.

Currently, machine learning methods, such as support vector machines, radial basis function neural network, and extreme learning machine, are widely used in medical fields [9–11]. BP-ANN is a classical artificial neural network, and is a computational model inspired by the nervous system of the brain. It has been used to diagnose diseases, predict and quantify the synergism of drugs, and to predict the outcome of treatments [12–14]. Because BP-ANN has received increasing attention, we introduced it into this study. We recruited normal-weight and overweight Chinese subjects to investigate the relationship of ALT and AST with CBC, and developed a BP-ANN prediction model.

Material and Methods

Subjects

The study and the procedure for enrollment were approved by the Ethics Committee of the First Affiliated Hospital of College of Medicine, Zhejiang University and the First Affiliated Hospital of Wenzhou Medical University. Subjects who were enrolled in this study provided signed written consent. These procedures for informed consent and enrollment were in accordance with the detailed regulations regarding informed consent described in the guidelines. All methods of this study were conducted in accordance with the Declaration of Helsinki.

Participants were excluded if they had any history of serious liver and kidney disease, cardiovascular disease, chronic metabolic disorders, or blood system diseases, such as all kinds of viral hepatitis and nephritis, cirrhosis, type 2 diabetes, anemia, polycythemia, and thrombocytopenia.

We collected fasting blood samples in the morning at the physical examination centers of the hospitals. Height and weight were measured to calculate BMI (weight [kg]/height [m²]). We placed 3–4-mL blood samples into the separation gel coagulation promoting tubes, and the serum samples were separated for ALT and AST tests. Another 2 mL of venous blood was collected into heparinized tubes for determination of CBC. ALT and AST were detected using a Beckman-Coulter AU5800 auto-biochemical analyzer, and CBC testing was performed using a BC-5500 automatic blood cell analyzer.

Statistical analysis

According to BMI, the subjects were divided into a normal-weight group (18.5–23.9 kg/m²) and an overweight group (24.0–27.9 kg/m²). Before data analysis, one-sample Kolmogorov-Smirnov test and homogeneity test of variances were used to analyze the distribution of the data of ALT, AST, and blood indexes in the 2 groups. Then, one-way ANOVA was used for normally distributed data, and the homogeneity test of variances or non-parametric test was used to compare the means. The relationships of ALT and AST with blood indexes were analyzed by bivariate correlations. The Pearson or Spearman correlation analysis was used for data with or without a normal distribution, respectively. The possible correlations between the CBC indexes were analyzed by colinearity diagnostics, which performed regression-linear analysis by the selected “enter” method. After that, the regression models were generated by multiple linear regression (MLR) analysis.

Development of BP-ANN model

To achieve a better effect than that of MLR, the BP-ANN model was developed. Firstly, all input data were normalized and

divided as a training set and a testing set by 10-fold cross validation. Then, a BP-ANN model was developed. The flowchart of developed BP-ANN model was showed in Figure1. For example, when developing ALT prediction model, the correlated CBC indexes were used as the input layer of BP-ANN, the out layer was ALT, and the hidden layer (m) was calculated according to the formula $m = \sqrt{n+l+a}$ [15]. In this study, n was the number of CBC indexes selected in the input layer, l was 1, and a was 10. The transfer function “tansig” was used as the parameter of hidden layer nodes, and “purelin” was used as the parameter of output layer node. To prevent overfitting, the bayesian regularization algorithm was used to improve the network performance. When setting all the properties of BP-ANN, the ALT prediction model was performed in Matlab R2011a. The goodness of fit of the BP-ANN model was judged by mean square error, magnitude of gradient, and the correlation coefficient.

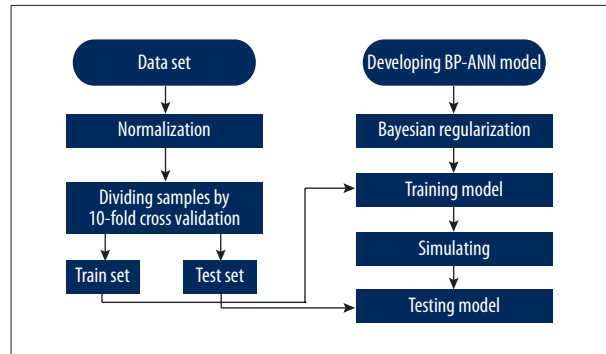

Figure 1. Flowchart of BP-ANN algorithm.

Table 1. Clinical characteristics of normal-weight and overweight subjects (mean ±SD).

Index	Normal-weight		Overweight	
	Male (214)	Female (358)	Male (256)	Female (92)
Age (year)	41.43±10.01	42.37±10.52	43.12±10.03	50.45±11.42
BMI (Kg/m ²)	22.04±1.33	21.34±1.39	25.70±1.27	25.49±1.06
ALT (U/L)	28.56±21.72	16.15±9.30	37.42±23.76	22.95±14.08
AST (U/L)	23.87±10.89	19.11±5.67	25.61±9.62	21.71±7.94
WBC (10 ⁹ /L)	6.55±1.53	5.87±1.56	8.43±2.17	7.52±1.99
PMC (%)	0.08±0.02	0.07±0.02	0.07 ±0.02	0.07±0.02
AVM (10 ⁹ /L)	0.49±0.14	0.38±0.12	0.51±0.17	0.42±0.13
RBC (10 ¹² /L/L)	5.04±0.39	4.45±0.35	5.16±0.41	4.48±0.27
HCT (%)	0.46±0.03	0.41±0.03	0.47±0.02	0.41±0.03
PLC (%)	0.37±0.08	0.37±0.08	0.37±0.08	0.36±0.08
AVLC (10 ⁹ /L)	2.33±0.64	2.06±0.55	2.51±0.70	2.16±0.53
MCV (fL)	92.43±5.09	91.48±5.94	91.39±5.80	91.45±5.37
MCH (pg)	30.59±1.93	29.49±2.32	30.49±2.26	29.48±2.24
MCHC (g/L)	330.87±8.30	322.16±9.24	333.40±9.31	322.02±11.56
MPL (fL)	10.96±1.43	10.77±1.97	10.87±1.66	10.94±1.68
AVE (10 ⁹ /L)	0.17±0.13	0.12±0.10	0.18±0.12	0.13±0.07
PE (%)	0.03±0.02	0.02±0.02	0.03±0.02	0.02±0.01
HB (g/L)	153.87±10.33	130.66±9.50	156.54±9.90	131.96±11.38
PLT (10 ⁹ /L)	218.62±45.73	224.76±50.47	217.68±48.35	237.95±53.81
THR (%)	0.24±0.05	0.24±0.06	0.24±0.06	0.26±0.06
PN (%)	0.52±0.08	0.54±0.08	0.53±0.08	0.55±0.08
AVN (10 ⁹ /L)	3.37±1.06	3.07±1.03	3.68±1.26	3.34±1.17
RBCVD (%)	12.66±0.62	12.87±1.03	12.68±0.73	13.01±1.19

Table 2. Correlation of ALT with blood indexes in normal-weight and overweight subjects.

Index	Normal-weight				Over weight			
	Male (214)		Female (358)		Male (256)		Female (92)	
	Correlation coefficient	P	Correlation coefficient	P	Correlation coefficient	P	Correlation coefficient	P
WBC	0.146*	0.03	0.01	0.89	0.09	0.15	0.00	0.99
PMC	0.13	0.06	0.08	0.13	0.03	0.69	0.09	0.39
AVM	0.143*	0.04	0.09	0.08	0.126*	0.04	0.11	0.30
RBC	0.12	0.07	0.121*	0.02	0.177**	0.00	0.220*	0.04
HCT	0.167*	0.02	0.223**	0.00	0.148*	0.02	0.279**	0.01
PLC	-0.04	0.58	0.01	0.80	-0.02	0.72	0.10	0.33
AVLC	0.05	0.49	0.03	0.53	0.06	0.31	0.14	0.19
MCV	0.00	0.99	0.06	0.30	-0.08	0.22	0.12	0.25
MCH	0.07	0.35	0.06	0.22	-0.02	0.72	0.14	0.19
MCHC	0.11	0.12	0.01	0.79	0.10	0.12	0.17	0.10
MPL	0.08	0.25	0.05	0.33	0.01	0.84	0.07	0.51
AVE	0.07	0.30	-0.04	0.50	-0.07	0.30	-0.04	0.69
PE	0.02	0.78	-0.03	0.60	-0.08	0.19	0.03	0.75
HB	0.184**	0.01	0.212**	0.00	0.156*	0.01	0.287**	0.01
PLT	-0.05	0.44	-0.05	0.38	0.05	0.39	0.03	0.75
THR	-0.03	0.67	-0.02	0.67	0.06	0.34	0.06	0.60
PN	0.00	0.99	-0.03	0.63	0.03	0.63	-0.11	0.32
AVN	0.12	0.07	0.00	0.98	0.11	0.09	0.03	0.79
RBCVD	-0.06	0.42	0.00	0.98	0.00	0.98	0.05	0.62

* $P < 0.05$; ** $P < 0.01$.

Results

Characteristics of the participants

In total, 918 subjects, including 572 normal-weight (214 male, 358 female) and 346 overweight (256 male, 92 female) individuals, were involved in this study. The indexes of CBC included the percentage of monocytes (PMC), white blood cell count (WBC), red blood cell count (RBC), hematocrit (HCT) level, percentage of leukomonocytes (PLC), absolute value of leukomonocytes (AVLC), mean corpuscular volume (MCV), mean corpuscular hemoglobin (MCH), mean corpuscular hemoglobin concentration (MCHC), mean platelet volume (MPL), absolute value of eosinophils (AVE), percentage of eosinophils (PE), absolute value of monocytes (AVM), hemoglobin (HB) level, platelet count (PLT), thrombocytocrit (THR), percentage of neutrophils

(PN), absolute value of neutrophils (AVN), and volume distribution width of red cells (RBCVD). The clinical characteristics of the normal-weight and overweight subjects, including age, BMI, ALT, AST, and CBC indexes, are shown in Table 1.

Correlations between ALT and AST and blood indexes

According to the Shapiro-Wilk test, ALT and AST were both non-normally distributed ($P < 0.01$) in normal-weight and overweight subjects. The correlations of ALT and AST with blood indexes are shown in Tables 2 and 3, respectively. The Spearman correlation analysis revealed that the correlation of ALT with CBC indexes was almost unchanged in normal-weight and overweight groups. ALT was related to white blood cell count, absolute value of monocytes, hematocrit, and hemoglobin in the male normal-weight group, while ALT was related to red blood

Table 3. Correlation of AST with blood indexes in normal-weight and overweight people.

Index	Normal-weight				Over weight			
	Male (214)		Female (358)		Male (256)		Female (92)	
	Correlation coefficient	P	Correlation coefficient	P	Correlation coefficient	P	Correlation coefficient	P
WBC	0.11	0.12	-0.03	0.57	0.07	0.30	-0.03	0.75
PMC	0.12	0.07	0.06	0.25	0.10	0.11	0.15	0.16
AVM	0.13	0.05	0.01	0.93	0.157*	0.01	0.05	0.62
RBC	0.03	0.68	-0.01	0.86	0.04	0.55	0.12	0.25
HCT	0.13	0.06	0.07	0.20	0.07	0.26	0.303**	0.00
PLC	-0.10	0.16	0.04	0.50	-0.06	0.30	0.19	0.07
AVLC	-0.02	0.78	-0.06	0.29	0.01	0.84	0.13	0.22
MCV	0.11	0.12	0.08	0.16	-0.04	0.54	0.323**	0.00
MCH	0.11	0.11	0.07	0.22	0.00	0.99	0.287**	0.01
MCHC	0.03	0.65	-0.03	0.57	0.05	0.47	0.04	0.71
MPL	0.06	0.42	0.09	0.10	0.03	0.70	0.332**	0.00
AVE	0.03	0.62	-.122*	0.02	-0.06	0.35	-0.01	0.93
PE	-0.02	0.83	-0.10	0.06	-0.06	0.33	-0.01	0.95
HB	0.12	0.08	0.06	0.26	0.08	0.20	0.287**	0.01
PLT	-0.01	0.88	-0.09	0.09	-0.03	0.68	-0.05	0.61
THR	0.02	0.74	-0.07	0.20	-0.02	0.82	0.12	0.25
PN	0.06	0.40	-0.02	0.66	0.04	0.51	-0.21	0.05
AVN	0.137*	0.05	-0.05	0.32	0.08	0.21	-0.13	0.21
RBCVD	0.00	0.97	0.08	0.14	0.02	0.73	-0.04	0.68

* $P < 0.05$; ** $P < 0.01$.

cell count, hematocrit, hemoglobin in the female group. In the overweight group, ALT was related to absolute value of monocytes, red blood cell count, hematocrit, and hemoglobin in the male overweight group, and related to red blood cell count, hematocrit, hemoglobin in the female overweight group. AST was different from ALT; there was only 1 index related with AST in the male normal-weight, female normal-weight, and male overweight groups (Tables 2, 3).

Colinearity diagnostics

The correlations analysis indicated that ALT was suitable to develop a regression model in normal-weight and overweight groups. Therefore, further colinearity diagnostics analysis was conducted. The results showed that the tolerance of most of CBC indexes in normal-weight and overweight subjects were

lower than 0.1, the multiple dimension eigenvalue was near to "0", and condition index was more than "10". Therefore, there was colinearity between these CBC indexes when ALT was selected as the dependent variable.

Regression model of ALT

Because there was colinearity between CBC indexes, it was necessary to develop a regression model in selection of independent variables. To prevent the abnormal solution caused by the multi-colinearity, multiple linear regression (MLR) analysis was conducted by stepwise method.

The results showed only 4 variables – hemoglobin, the percentage of monocytes, hematocrit, and red blood cell count – were involved in MLR models. The Durbin-Watson values of 4

Table 4. Summary of ALT regression model based on MLR analysis in normal and overweight people.

Group	Predictors: (Constant)	R	R ²	Adjusted R	STD. error of the estimate	Durbin-Watson
Normal-weight	HB, PMC	0.376	0.142	0.139	15.143	2.023
Overweight	HCT, RBC, PMC	0.334	0.111	0.104	21.284	1.783

Table 5. Regression coefficients of ALT regression model based on MLR analysis in normal-weight and overweight people.

Group	Model	Unstandardized coefficients		Standardized coefficients	t	Sig.	Colinearity statistics	
		B	STD. error	Beta			Tolerance	VIF
Normal weight	Constant	-39.135	6.218		-6.294	0		
	HB	0.38	0.043	0.348	8.895	0	0.987	1.013
	PMC	97.364	34.601	0.11	2.814	0.005	0.987	1.013
Over-weight	Constant	-55.757	14.606		-3.817	0		
	HCT	105.037	44.448	0.17	2.363	0.019	0.502	1.99
	RBC	6.954	3.301	0.148	2.107	0.036	0.524	1.907
	PMC	14.579	7.089	0.108	2.057	0.04	0.936	1.069

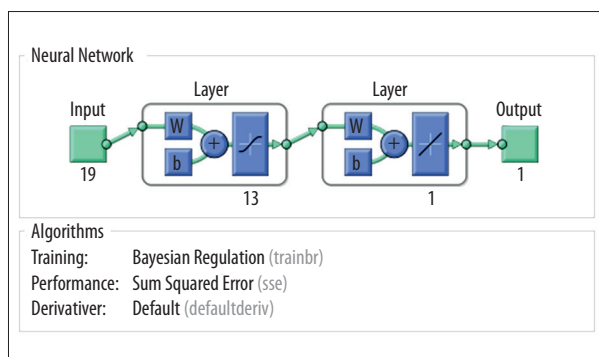

Figure 2. Process of BP-ANN training.

regression models were all between 0 and 4, which indicated the 2 item sets were independent of each other (Table 4). The beta values indicated these 4 independent variables have strongest contribution to ALT, and had no colinearity between each other (Table 5).

BP-ANN prediction model of ALT

The BP-ANN process is shown in Figure 2. The CBC data of normal-weight and overweight people were input into the layer, and ALT was set as the out layer. After training 1000 epochs, the ALT BP-ANN models performed well both in normal-weight and overweight people. The values of MSE, MOG, and correlation coefficient are shown in Table 6. Compared with MLR, BP-ANN had a higher regressions coefficient.

To compare and contrast, we also developed the BP-ANN model of AST with the same BP-ANN architecture as ALT. The results showed that the BP-ANN model of AST had a lower regressions coefficient than the ALT model after training for 1000 epochs (Table 6).

Discussion

ALT and AST are both common indexes used as indicators of liver function in physical examinations and clinical practice. Moreover, they are key enzymes in the liver related to carbohydrate intake and are important in the metabolic processes that convert food into energy [16,17]. They are also the enzymes that are correlated most strongly with liver fat accumulation and are measured routinely in screening assays for the detection of nonalcoholic fatty liver disease in the general population [18]. Thus, developing ALT and AST prediction models will be useful for the detection of early liver impairment in overweight people when they have CBC performed.

Here, we first analyzed the relationships of ALT and AST with indexes of CBC in Chinese subjects. According to the correlation analyses of AST and ALT with CBC indexes in normal-weight and overweight subjects, ALT showed higher correlations with certain indexes of CBC than did AST. For example, ALT was related to white blood cell count, absolute value of monocytes, hematocrit, and hemoglobin in the male normal-weight group,

Table 6. Fitness index of the BP-ANN model for ALT and AST performed in normal-weight and overweight people.

Parameter	ALT		AST	
	Normal-weight	Overweight	Normal-weight	Overweight
Mean squared error	11.9979	30.1028	16.3497	19.788
Magnitude of the gradient	0.77196	2.3859	1.0115	2.0316
Correlation coefficient	0.4279	0.35076	0.37501	0.29419

and was related to red blood cell count, hematocrit, and hemoglobin in the female normal-weight group. There was only 1 index related with AST in the male normal-weight and female normal-weight group. Therefore, ALT was a suitable index for developing a regression model.

The further colinearity diagnostics showed that there was colinearity between these CBC indexes. To prevent the abnormal solution caused by the multi-colinearity, we chose the “step-wise” method to develop a regression model. In theory, the colinearity will not decrease the prediction accuracy or the utility of a regression model. Therefore, the MLR analysis was of practical meaning and of reference value. However, MLR analysis was not as smart as the artificial intelligence algorithm. We also evaluated the variable importance in the projection (VIP) in the ALT regression model by partial least squares analysis. The result showed the most important variables (VIP >1) were mean corpuscular hemoglobin concentration, platelets, and hemoglobin. For more detailed VIP information, please refer to the Supplementary Files.

BP-ANN is a type of artificial neural network, which can perform machine learning and pattern recognition. It has been used widely in the medical area. Back-propagation is a kind of artificial intelligence algorithm that calculates the gradient of a loss function with respect to all the weights in the network [19]. The prediction accuracy of BP-ANN is influenced by not only the developing parameters of the model, but also the relationship of input variable and output variable. In most situations, more relevant input variables are selected as the input layer, resulting in high prediction accuracy [20]. However, use of too many variables in the model will result in overfitting, so we used the bayesian regularization algorithm to improve the network performance.

In this study, BP-ANN models of ALT and AST both performed well in normal-weight and overweight subjects. After training 1000 epochs, the ALT BP-ANN models performed well both in normal-weight and overweight people. The regression coefficients of ALT BP-ANN models were higher than in MLR analysis, and the AST model also reached better regression coefficients. Thus, the BP-ANN models were more effective and accurate than MLR in predictions of ALT in normal-weight and overweight subjects.

Conclusions

Our investigation indicated that ALT was related to white blood cell count, absolute value of monocytes, hematocrit, and hemoglobin in the male normal-weight group, and was related to red blood cell count, hematocrit, and hemoglobin in the female group. In the overweight group, ALT was related to absolute value of monocytes, red blood cell count, hematocrit, and hemoglobin in the male overweight group, and was related to red blood cell count, hematocrit, and hemoglobin in the female overweight group. There was only 1 index related with AST in the male normal-weight group, the female normal-weight group, and the male overweight group. ALT was a more suitable index than AST for developing the regression model. ALT can be predicted by relevant indexes in normal-weight and overweight individuals based on a BP-ANN model, which was better than MLR analysis.

Conflict of interest

None.

Supplementary Files

Figure and Table of VIP of CBC indexes in modeling ALT regression model generated by PLS algorithm

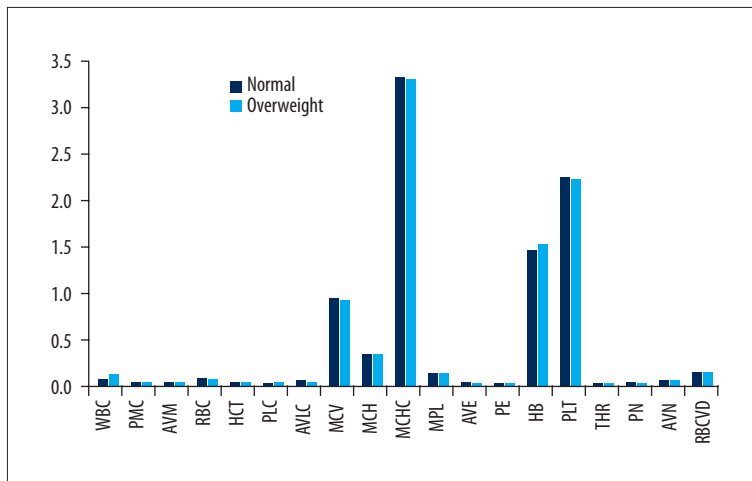

Index	Normal	Overweight
WBC	0.06334572	0.082934
PMC	0.00074269	0.00072
AVM	0.00449666	0.004999
RBC	0.04825029	0.050284
HCT	0.0044334	0.004572
PLC	0.00375976	0.003649
AVLC	0.02242699	0.024565
MCV	0.93147429	0.905918
MCH	0.30480027	0.300622
MCHC	3.30812813	3.291114

Index	Normal	Overweight
MPL	0.11068251	0.108181
AVE	0.00149401	0.001649
PE	0.00023301	0.00024
HB	1.45187567	1.51757
PLT	2.22508473	2.217056
THR	0.00241222	0.002406
PN	0.00534763	0.005287
AVN	0.03267109	0.036658
RBCVD	0.12861821	0.126498

References:

- Nowakowski GS, Hoyer JD, Shanafelt TD et al: Using smudge cells on routine blood smears to predict clinical outcome in chronic lymphocytic leukemia: A universally available prognostic test. *Mayo Clin Proc*, 2007; 82: 449–53
- Piperno A: Faecal occult blood test and iron deficiency anaemia. *Dig Liver Dis*, 2012; 44: 625
- Takahashi T, Maruoka H: [Blood cytokine levels as a clinical laboratory test]. *Rinsho Byori*, 2007; 55: 272–79 [in Japanese]
- Yu AS, Keeffe EB: Elevated AST or ALT to nonalcoholic fatty liver disease: Accurate predictor of disease prevalence? *Am J Gastroenterol*, 2003; 98: 955–56
- Kapadia S, Hapani S, Choueiri TK, Wu S: Risk of liver toxicity with the angiogenesis inhibitor pazopanib in cancer patients. *Acta Oncol*, 2013; 52: 1202–12
- Hu C, Deng C, Song G et al: Prevalence of autoimmune liver disease related autoantibodies in Chinese patients with primary biliary cirrhosis. *Dig Dis Sci*, 2011; 56: 3357–63
- Liu L, Zhong S, Yang RZ et al: Expression, purification, and initial characterization of human alanine aminotransferase (ALT) isoenzyme 1 and 2 in High-five insect cells. *Protein Expr Purif*, 2008; 60: 225–31
- Hu L, Wang F, Xu J et al: Prediction of liver injury using the BP-ANN model with metabolic parameters in overweight and obese Chinese subjects. *Int J Clin Exp Med*, 2015; 8: 13359–64
- Amato F, Lopez A, Pena-Mendez EM et al: Artificial neural networks in medical diagnosis. *J Appl Biomed*, 2013; 11: 47–58
- Wang XQ, Zhang ML, Ma JS et al: Metabolic changes in paraquat poisoned patients and support vector machine model of discrimination. *Biol Pharm Bull*, 2015; 38: 470–75
- Chen HL, Yang B, Liu DY et al: Using blood indexes to predict overweight statuses: An extreme learning machine-based approach. *PLoS One*, 2015; 10(11): e0143003
- Pivetta T, Isaia F, Trudu F et al: Development and validation of a general approach to predict and quantify the synergism of anti-cancer drugs using experimental design and artificial neural networks. *Talanta*, 2013; 115: 84–93
- Larder B, Wang DC, Revell A et al: The development of artificial neural networks to predict virological response to combination HIV therapy. *Antivir Ther*, 2007; 12: 15–24
- Qaderi A, Dadgar N, Mansouri H et al: Modeling and prediction of cytotoxicity of artemisinin for treatment of the breast cancer by using artificial neural networks. *Springerplus*, 2013; 2: 340

15. Xu JF, Xu J, Li SZ et al: Transmission risks of schistosomiasis japonica: Extraction from back-propagation artificial neural network and logistic regression model. *PLoS Negl Trop Dis*, 2013; 7: e2123
16. Fustinoni S, De Vecchi M, Bordini L et al: Validity of carbohydrate-deficient transferrin (CDT) in assessing chronic abuse of ethyl alcohol in urban public transport workers. *Med Lav*, 2009; 100: 359–69
17. Goletzke J, Buyken AE, Gopinath B et al: Carbohydrate quality is not associated with liver enzyme activity and plasma TAG and HDL concentrations over 5 years in an older population. *Br J Nutr*, 2013; 110: 918–25
18. Zhang B, Xue CH, Hu XQ et al: Dietary sea cucumber cerebroside alleviates orotic acid-induced excess hepatic adipogenesis in rats. *Lipids Health Dis*, 2012; 11: 48
19. Wesolowski M, Suchacz B, Konieczynski P: The application of artificial neural networks for the selection of key thermoanalytical parameters in medicinal plants analysis. *Comb Chem High Throughput Screen*, 2003; 6: 811–20
20. Trost SG, Zheng YL, Pfeiffer KA, Wong WK: Artificial neural networks to predict physical activity type and energy expenditure in children and adolescents. *Med Sci Sports Exerc*, 2012; 44: 216–17