

Received: 2017.07.24
Accepted: 2017.10.02
Published: 2018.03.26

Limited Dynamic Hip Screw for Treatment of Intertrochanteric Fractures: A Biomechanical Study

Authors' Contribution:
Study Design A
Data Collection B
Statistical Analysis C
Data Interpretation D
Manuscript Preparation E
Literature Search F
Funds Collection G

ABCFG 1 **Chunlei Zhang**
BF 2 **Bin Zhang**
AG 1 **Qirong Dong**
BEF 3 **Dawei Ge**

1 Department of Orthopedics, The Second Affiliated Hospital of Soochow University, Suzhou, Jiangsu, P.R. China
2 Department of Orthopedics, Shuyang Hospital of Traditional Chinese Medicine Affiliated to Nanjing University of Chinese Medicine, Nanjing, Jiangsu, P.R. China
3 Department of Orthopedics, The First Affiliated Hospital with Nanjing Medical University, Nanjing, Jiangsu, P.R. China

Corresponding Authors: Qirong Dong, e-mail: dqr@szgk.net, Dawei Ge, e-mail: gdw02115252@163.com

Source of support: This work was supported by the "333 Project" Research Foundation in Jiangsu Province, China (No. 201237)

Background: The aim of this article is to introduce a novel technique of limited dynamic hip screw (LDHS) in the treatment of intertrochanteric fractures and to evaluate its biomechanical effects.

Material/Methods: Based on the principle of providing both dynamic and static pressure to stabilize the fracture, we improved the dynamic hip screw (DHS) and designed the LDHS. Six fresh cadavers were collected and intertrochanteric fracture models were established, including Evan's type I fracture (n=3) and type II (n=3). We used the left-to-right comparison in this study. LDHS technique was performed on the left femoral head of each cadaver (LDHS group: n=6), while DHS was performed on the right side (DHS group: n=6). After fixation by either LDHS or DHS, compressive strength, rigidity, shear stress and strain, torsional properties, and ultimate loads were measured and compared in both groups.

Results: Under the 1200 N pressure, compressive strength, rigidity, shear stress and strain, and ultimate loads of LDHS were better than those of DHS in the 2 groups. All differences were statistically significant. Although LDHS enhanced the torsional properties, there was no significant difference.

Conclusions: Our study demonstrates that the biomechanical effects of LDHS are superior than those of DHS, and there was no screw failure after implantation. Armed with those better properties, LDHS, as a new internal fixation device, may be a good alternative option in the treatment of intertrochanteric fractures.

MeSH Keywords: **Biomedical Research • Cadaver • Hip Fractures • Internal Fixators**

Full-text PDF: <https://www.medscimonit.com/abstract/index/idArt/906351>

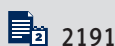

2191



5



2



21



Background

Intertrochanteric femur fracture is common in the aged population. With the improvement in surgical technique and continuous developments in material for internal fixation, surgical treatment of intertrochanteric femur fractures has become a preferred method. In patients with intertrochanteric femur fractures, the mortality rate in the traction treatment group is as high as 34.6%, while that in the internal fixation group is only 17.5% [1]. The treatment of intertrochanteric hip fractures using extra-medullary fixation devices mainly includes dynamic hip screw (DHS) and sliding/locking hip screw/nail plate systems.

DHS is generally considered to be an ideal choice as it provides both the dynamic and static pressure to stabilize the fracture [2]. However, unlimited dynamic pressure tends to cause screw displacement and can lead to several complications, such as extrusion of the screw, affected limb shortening, secondary fracture displacement, or coxa vara [3,4]. The locking proximal femoral plate (LPFP) is one of the locking hip screw systems that is known to provide immediate angular stability in the proximal femur. However, pressure at the junction of the locking screws tends to cause hardware failure, including screw breakage, loosening, fracture, and non-union [5,6]. This raises concerns about the clinical application of LPFP. Proximal femoral nail antirotation (PFNA) is an intramedullary fixators system known to provide centrality fixation with a short weight-bearing arm, which bears the axial pressure from the body weight. However, PFNA damages the bone marrow cavity and the inside of the bone cortex [7].

In our research, which maintains the principles of DHS, we designed a new hip fixation device named the limited dynamic hip screw (LDHS). This device restricts the range of screw displacement so as to maintain screw stability and facilitate bone union.

The primary purpose of this study was to investigate the biomechanical effects of LDHS and to provide a basis for future applications of LDHS in the treatment of intertrochanteric hip fractures.

Material and Methods

Design of LDHS

Based on the principles of DHS providing both dynamic and static pressure to stabilize the fracture, the LDHS was designed and manufactured. The LDHS is composed of 4 main parts: a sliding hip screw (SHS), a lateral plate (LP), a fixed screw, and a locking nut (Figure 1, Chinese patent: ZL201020220250.3).

After placement of the locking nut, there is a sliding space (0.3–0.5 mm) between the fixed screw and the locking nut, which limits the SHS outward displacement.

Specimens and fracture model establishment

Intertrochanteric fracture models were established in a total of 6 fresh cadavers provided by the Department of Anatomy at Soochow University (4 males, 2 females; mean age 68.4 years; average weight 64 kg), including Evan's type I fracture (n=3) and type II (n=3), according to a previous report [7].

To reduce various biases among different cadavers, we used the left-to-right comparison in this study. LDHS technique was performed on the left femoral head of each cadaver (LDHS group: n=6), while DHS was performed on the right side (DHS group: n=6).

This study was approved by the Ethics Committee of the Second Affiliated Hospital of Soochow University. Prior to testing, the soft tissue was stripped from the femurs and X-ray imaging was used to exclude femurs with fractures, tumors, and other pathological diseases.

Biomechanical measurement

After fixation by either LDHS or DHS, fractured femurs underwent identical biomechanical measurements for compressive strength, rigidity, shear stress and strain, torsional properties, and ultimate loads. Measurements were performed according to methods described previously [8]. Before testing, 6 sensors ($R=120\Omega\pm 0.1\%$, $R=2.16$, 1.50×1.50 mm) were placed around the femurs, mimicking the single-leg stance loading configuration by taking into account the effects of abductor muscles on the femurs. Baselines of material mechanical properties were measured before starting all experiments. Femurs were loaded and unloaded 3 times with a weight of 100 N to minimize the temporal influence on femur bone loosening and distortion. A WDW computer-controlled electronic pull testing machine (Changchun New Test Instrument Co., LTD, Changchun, China) was used for the serial load assessment, from 0 to 1200 N, and at the rate of 1.5 mm/s. The measurement of horizontal (U) and vertical (V) movements of femurs was performed using the KG-101 grating displacement measurement system provided by the Electrical and Mechanical Factory of Shanghai University (Shanghai, China). The operational setup is illustrated in Figure 2.

Statistical analysis

SPSS 20.0 software (IBM, Armonk, NY, USA) was used for statistical analysis. Mechanical parameters of each group are presented as mean \pm standard deviation ($\bar{x}\pm SD$). The significance

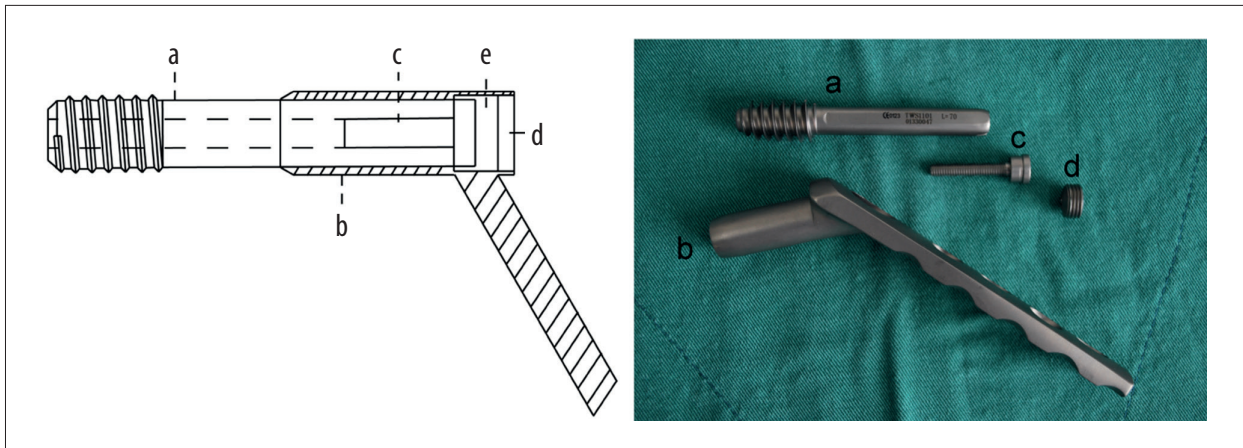

Figure 1. Design of limited dynamic hip screw (LDHS). a – Sliding hip screw (SHS); b – lateral plate (LP); c – a fixed screw; d – a locking nut; e – a sliding space (0.3–0.5 mm) between fixed screw and locking nut.

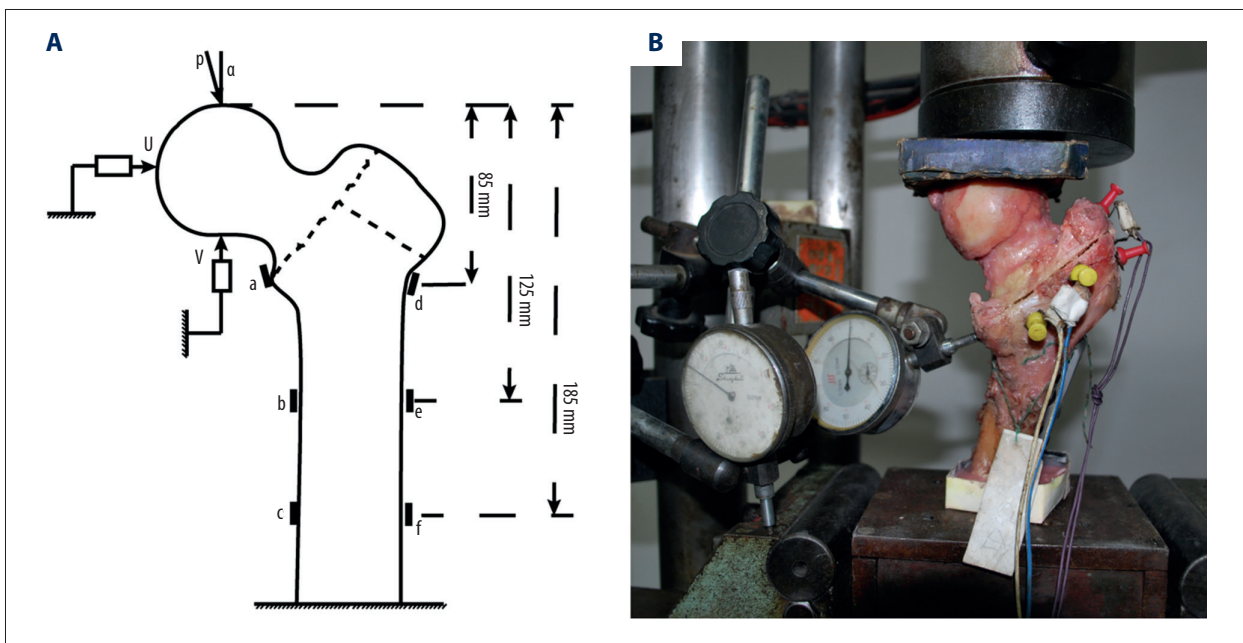

Figure 2. Schematic diagram of experiments and illustration of actual operation. (A) Schematic diagram of Evan's type I or II fracture models. P – load; U – sensor of horizontal displacement; V – sensor of vertical displacement; a–f – location of resistance chip measurement. (B) Illustration of actual operation.

of differences in the parameters was analyzed using the independent-samples *t* test, and $p < 0.05$ was considered to represent a statistically significant difference.

Results

Compressive strength of the femoral head

To evaluate the effects of LDHS in different types of intertrochanteric fractures, we made comparisons in both Evan's type I and type II fracture models. For Evan's type I, under 1200N

loading, LDHS provided 18% better stability than DHS for outside (OS) fixation and 11% better stability for the inside (IS) fixation. Similarly, for Evan's type II fracture, LDHS was 14% better than DHS for both OS and IS fixations under the same loading. The differences between DHS and LDHS in both Evan's type I and type II were statistically significant ($p < 0.05$) (Table 1), suggesting that the LDHS design provides better compressive strength for the femur, especially for outside fixation.

Table 1. Compressive strength of LDHS and DHS in Evan’s type I and Evan’s type II fracture models, under a load of 1200 N (MPa, $\bar{x}\pm S$).

	Evan’s I		Evan’s II	
	OS	IS	OS	IS
DHS	1.31±0.12	1.10±0.10	0.98±0.10	0.81±0.10
LDHS	1.60±0.18	1.24±0.12	1.14±0.11	0.94±0.10
t value	2.712	2.274	2.643	2.386
P value	0.0248	0.0361	0.0214	0.0411

OS – outside fixation; IS – inside fixation.

Table 2. Rigidity of the LDHS and DHS in Evan’s I and Evan’s II fracture models (N/mm, $\bar{x}\pm S$).

	Evan’s I		Evan’s II	
	EF	GF	EF	GF
DHS	1539±165	1053±111	1364±129	1017±109
LDHS	1714±178	1225±118	1558±169	1132±116
t value	2.317	2.334	2.425	2.356
P value	0.0219	0.0301	0.0274	0.0288

EF – axial rigidity; GF – horizontal shear rigidity.

Table 3. Shear stress and strain of LDHS and DHS in Evan’s type I and Evan’s type II fracture models ($\bar{x}\pm S$).

	Evan’s I		Evan’s II	
	Shear stress (MPa)	Shear strain ($\mu\epsilon$)	Shear stress (MPa)	Shear strain ($\mu\epsilon$)
DHS	3.22±0.30	56.00±5.30	2.22±0.18	37.89±0.36
LDHS	3.86±0.38	64.00±4.42	2.51±0.21	42.66±0.41
t value	2.868	3.256	2.372	3.486
P value	0.0313	0.0419	0.0284	0.0303

OS – outside fixation; IS – inside fixation.

Rigidity of the femoral head

Rigidity of the femur measures the extent of femoral deformity under external pressure, which is represented by axial rigidity (EF) and horizontal shear rigidity (GF). Table 2 lists the rigidity measurements of the femoral head between the LDHS group and DHS group. Under 1200N loading, for Evan’s type I fracture, LDHS provided significantly greater EF and GF compared to DHS (10% and 11%, respectively); while for Evan’s type II fracture, LDHS still provided significantly higher EF and GF than DHS (13% and 14%, respectively). These results show that LDHS is superior to DHS in providing resistance to deformation.

Shear stress and strain of the femoral head

Even after stabilization of an intertrochanteric fracture, large hip loads can still cause implant cutout, downward slipping/displacement, or pelvic migration. The results of shear stress (τ) and shear strain (γ) measurement for the LDHS and DHS under 1200 N load pressure are presented in Table 3. We found that shear stress of LDHS was 16% and 12% higher for Evan’s type I fracture and type II fracture, respectively, compared with DHS. In contrast, compared with DHS, shear strain of LDHS was 13% and 12% lower for Evan’s type I fracture and type II fracture, respectively. All differences were statistically significant. Taken together, these results suggested that the LDHS can more effectively prevent implant nails from sliding, strengthen the femoral neck, enhance load resistance, and decrease the incidence of pelvic migration.

Table 4. Torque and torsional rigidity of LDHS and DHS in Evan's type I and Evan's type II fracture models ($\bar{x} \pm s$).

	Evan's I		Evan's II	
	Torque (N×M)	Torsional rigidity (N×M/deg)	Torque (N×M)	Torsional rigidity (N×M/deg)
DHS	3.16±0.28	1.09±0.07	2.01±0.17	1.06±0.04
LDHS	3.38±0.30	1.19±0.08	2.18±0.18	1.17±0.06
t value	1.125	3.254	1.227	3.147
P value	0.0876	0.0688	0.0736	0.0588

Table 5. Ultimate loads of LDHS and DHS in Evan's type I and Evan's type II fracture models ($\bar{x} \pm s$).

	Evan's I		Evan's II	
	Ps (N)	Δ (mm)	Ps (N)	Δ (mm)
DHS	2840±282	7.84±0.81	2014±220	8.04±0.86
LDHS	3218±301	8.84±0.82	2289±230	8.76±0.80
t value	2.117	1.503	3.241	1.062
P value	0.0206	0.2073	0.0436	0.3482

Ps – ultimate load; Δ – displacement of fractures.

Torsional properties of the femoral head

Femoral torsional properties were examined by the application of torsional load carried out at a clockwise rate of 0.032°/s and measured by torque and torsional rigidity. For fracture of Evan's type I, the torque and torsional rigidity of LDHS were 7% and 8% higher than those of DHS, respectively. In the Evan's type II fracture model group, 8% and 9% higher torque and torsional rigidity, respectively, were observed in LDHS compared with DHS. Although LDHS provided better torsional properties in the 2 groups, the differences were not statistically significant (Table 4).

Ultimate load of the femoral head

The ultimate load for a stabilized intertrochanteric fracture is defined as the limit loads that cause either a re-fracture of greater than 5 mm displacement, a major screw cutout, or screw slide. For Evan's type I and II fractures, the ultimate load of LDHS was significantly higher (by 11% and by 12%, respectively) than that of DHS (Table 5). Regarding the damage from the ultimate load, 7 models were due to displacement of more than 5 mm, and 5 models were due to re-fracture with constant cracking sounds and a significant slipping of the screw. The screws from the DHS-stabilized fracture slipped by 2.8 mm under 1200 N load and showed signs of early damage. It should be noted that the majority of both fixation mechanics remains intact except for the main screws. Therefore, based on these ultimate load measurements, LDHS provided better load capacity than DHS.

Discussion

Since 1951, when the Polish physician Ernst Pohl first demonstrated the use of the classic form of DHS for the treatment of femoral fractures, DHS has been considered to be the ideal treatment option for extra-medullary fixation of the intertrochanteric fracture, with features of solid screw-based fracture fixation, a yield point at the junction of the hip screws and steel plate, and dynamics and statics of double pressurization [9]. However, the unrestrained displacement of the dynamic screw and single screw with low resistance to the rotational pressure leads to higher failure rates in the treatment of osteoporosis-related or unstable fractures [5,10–12]. Gotfried et al. [13] modified the traditional DHS and designed and manufactured a new internal fixation system, named percutaneous compression plating (PCCP), which utilized a similar sliding-based pressurization method and used double screws to increase the resistance to rotational pressure, and the smaller wound and less bleeding help make it more applicable in clinical practice [14]. However, higher technical requirements and much X-ray exposure limited its wide application.

DHS provides continuous dynamic pressure to promote bone union and thus reduces the occurrence of nonunion. However, the unlimited dynamic pressure tends to cause complications and treatment failure [7]. It has been reported that when screw sliding exceeds 15 mm, it is considered a treatment failure [15]. LPFP offers an advantage of immediate stabilization, but disadvantages of complete lock-in-associated nonunion and high

incidence of internal fixation failure [16]. To deal with these clinical problems, LDHS preserves the feature of the traditional dynamic screw by keeping the screw sliding cavity, which not only maintains the dynamic pressure to facilitate bone union, but also prevents the main screw from unlimited outside sliding. These modifications effectively limit the main screw sliding and reduce the complications of DHS.

The present study demonstrates that LDHS significantly improved biomechanical properties compared with DHS. This is because LDHS limits the outward dislocation of the sliding hip screw, which strengthens the fixation of the screw and provides better structural stability. LDHS also reduces the incidence of coxa vara complications, making it suitable as an internal fixation treatment for unstable fractures. According to a study by Brandt et al. comparing the biomechanical properties of PCCP and DHS, LDHS has similar biomechanical properties to those of PCCP, which was superior to DHS [17]. Moreover, when the limited sliding reaches the final stage of de-dynamization due to a vibration between the plate cannula of the lateral plate and locking cap, the vibration between the fractured pieces could facilitate the bone union [18]. Wu et al. has also demonstrated that although cement-augmented DHS enhanced the screw fixation, it increases the incidence of delayed union and nonunion [19].

LDHS maintains the dynamic feature of the DHS to effectively enhance bone union. However, if the implant position is not selected correctly, implant failure and bone nonunion inevitably occur. Baumgaertner et al. proposed the concept of tip-apex distance (TAD) in 1995 as the predictor for a hip fracture fixation failure rate, and reported that for a TAD less than 20 mm, there would be a lower incidence of screw cutout, whereas for a TAD greater than 50 mm, the cutout rate is more than 60% [20]. Their study further suggested that it was better to implant the screw at the center of the femoral head to reduce the occurrence of screw cutout. Hsueh et al. evaluated 937

cases of intertrochanteric fractures and concluded that the TAD, screw position, and suboptimal fracture reduction are the main reasons for screw cutout [1]. In our study, we strictly followed the protocol to implant both LDHS and DHS screws at the center or lower 1/3 of the fractured femoral neck with a forward angle of 10–15°. The screw cutout was only observed when tested femurs were challenged with loads exceeding the ultimate load capacity. Buciuto and Hammer suggested that the ideal position for screw placement is 5–8 mm below the cartilage portion of the femur head, which provides a reliable fixation for the screws [21]. In summary, appropriate placement of LDHS is essential for the treatment of intertrochanteric fractures.

This study has certain limitations. The small sample size weakened our conclusions, but we could not justify an increase in the sample size because including more than 11 matched pairs would provide a statistical power of 80%. Additionally, although left-to-right comparison was used to control bias, including age, sex, and bone mineral density (BMD), we could not exclude all the effects of anatomical discrepancy between the 2 sides of each cadaver. Moreover, the superior biomechanical properties of LDHS were only demonstrated in cadavers, so further clinical studies are still required.

Conclusions

We introduce a novel LDHS technique for treating intertrochanteric fractures, and demonstrated its superior biomechanical effects compared to DHS. Our results show that LDHS, as a new internal fixation device, may be an alternative option in the treatment of intertrochanteric fractures.

Conflicts of interest

None.

References:

- Kesmezacar H, Ogut T, Bilgili MG et al: [Treatment of intertrochanteric femur fractures in elderly patients: Internal fixation or hemiarthroplasty]. *Acta Orthop Traumatol Turc*, 2005; 39: 287–94 [in Turkish]
- Hsueh KK, Fang CK, Chen CM et al: Risk factors in cutout of sliding hip screw in intertrochanteric fractures: an evaluation of 937 patients. *Int Orthop*, 2010; 34: 1273–76
- Said GZ, Farouk O, El-Sayed A, Said HG: Salvage of failed dynamic hip screw fixation of intertrochanteric fractures. *Injury*, 2006; 37: 194–202
- Rupprecht M, Grossterlinden L, Ruecker AH et al: A comparative biomechanical analysis of fixation devices for unstable femoral neck fractures: The intertan versus cannulated screws or a dynamic hip screw. *J Trauma*, 2011; 71: 625–34
- Singh AK, Narsaria N, G RA, Srivastava V: Treatment of unstable trochanteric femur fractures: proximal femur nail versus proximal femur locking compression plate. *Am J Orthop (Belle Mead NJ)*, 2017; 46: E116–23
- Agrawal P, Gaba S, Das S et al: Dynamic hip screw versus proximal femur locking compression plate in intertrochanteric femur fractures (ao 31a1 and 31a2): A prospective randomized study. *J Nat Sci Biol Med*, 2017; 8: 87–93
- Huang Y, Zhang C, Luo Y: A comparative biomechanical study of proximal femoral nail (intertan) and proximal femoral nail antitortation for intertrochanteric fractures. *Int Orthop*, 2013; 37: 2465–73
- Bong MR, Patel V, Iesaka K et al: Comparison of a sliding hip screw with a trochanteric lateral support plate to an intramedullary hip screw for fixation of unstable intertrochanteric hip fractures: A cadaver study. *J Trauma*, 2004; 56: 791–94
- Bridle SH, Patel AD, Bircher M, Calvert PT: Fixation of intertrochanteric fractures of the femur. A randomised prospective comparison of the gamma nail and the dynamic hip screw. *J Bone Joint Surg Br*, 1991; 73: 330–34
- Kim WY, Han CH, Park JI, Kim JY: Failure of intertrochanteric fracture fixation with a dynamic hip screw in relation to pre-operative fracture stability and osteoporosis. *Int Orthop*, 2001; 25: 360–62

11. Zou J, Xu Y, Yang H: A comparison of proximal femoral nail antirotation and dynamic hip screw devices in trochanteric fractures. *J Int Med Res*, 2009; 37: 1057–64
12. Zehir S, Zehir R, Zehir S et al: Proximal femoral nail antirotation against dynamic hip screw for unstable trochanteric fractures; A prospective randomized comparison. *Eur J Trauma Emerg Surg*, 2015; 41: 393–400
13. Gotfried Y: Percutaneous compression plating for intertrochanteric hip fractures: treatment rationale. *Orthopedics*, 2002; 25: 647–52
14. Koppel R, Vogt B, Schwyzer M: Immediate-early protein bicp22 of bovine herpesvirus 1 trans-represses viral promoters of different kinetic classes and is itself regulated by bicp0 at transcriptional and posttranscriptional levels. *Arch Virol*, 1997; 142: 2447–64
15. Andruszkow H, Frink M, Fromke C et al: Tip apex distance, hip screw placement, and neck shaft angle as potential risk factors for cut-out failure of hip screws after surgical treatment of intertrochanteric fractures. *Int orthop*, 2012; 36: 2347–54
16. Collinge CA, Hymes R, Archdeacon M et al: Unstable proximal femur fractures treated with proximal femoral locking plates: A retrospective, multicenter study of 111 cases. *J Orthop Trauma*, 2016; 30: 489–95
17. Brandt E, Verdonschot N, van Vugt A, van Kampen A: Biomechanical analysis of the percutaneous compression plate and sliding hip screw in intracapsular hip fractures: Experimental assessment using synthetic and cadaver bones. *Injury*, 2006; 37: 979–83
18. Yamaji T, Ando K, Wolf S et al: The effect of micromovement on callus formation. *J Orthop Sci*, 2001; 6: 571–75
19. Wu MH, Lee PC, Peng KT et al: Complications of cement-augmented dynamic hip screws in unstable type intertrochanteric fractures – a case series study. *Chang Gung Med J*, 2012; 35: 345–53
20. Baumgaertner MR, Curtin SL, Lindskog DM, Keggi JM: The value of the tip-apex distance in predicting failure of fixation of peritrochanteric fractures of the hip. *J Bone Joint Surg Am*, 1995; 77: 1058–64
21. Buciuoto R, Hammer R: Rab-plate versus sliding hip screw for unstable trochanteric hip fractures: Stability of the fixation and modes of failure – radiographic analysis of 218 fractures. *J Trauma*, 2001; 50: 545–50