

Fume particle size distribution and fume generation rate during arc welding of cast iron

Jyunya TAKAHASHI^{1*}, Hitoshi NAKASHIMA¹ and Nobuyuki FUJII¹

¹Polytechnic University, Japan

Received September 5, 2019 and accepted December 26, 2019

Published online in J-STAGE January 10, 2020

Abstract: This study measured the fume particle size distribution and fume generation rate during arc welding of cast iron and estimated the generation rate of respirable dust. In addition, the generation rate of particles with a diameter of 0.3 μm or less was estimated. In this experiment, three types of filler materials (mild steel wire, stainless steel wire, and mild steel covered electrodes) with main constituents of Fe or Fe-Cr-Ni, as proposed previously by the authors, were used. The welding methods were gas metal arc welding and shielded metal arc welding. The fumes measured in this research contained 73–91% respirable dust, and the fume generation rates were in the range of 1.96–12.2 mg/s. The results of this study were as follows: (i) the welding current affects the generation rate of respirable dust, and it is highly likely that the higher the fume generation rate, the more respirable dust is generated; (ii) the generation rates of respirable dust at low and high current were highest when mild steel covered electrodes and stainless steel wire was used, respectively; and (iii) the generation rate of particles with a diameter of 0.3 μm or less was highest when stainless steel wire is used.

Key words: Arc welding, Cast iron, Fume generation rate, Particle size distribution, Respirable dust, Respirators

Introduction

The arc welding process is generally known to generate a large amount of fumes that are highly hazardous to the human body. Since these fumes generally have an extremely small (0.005–20 μm) particle size¹⁾, the particles are carried by thermal updrafts generated by the hot welded part and are dispersed throughout the workplace. Because of this, an extremely large number of workers are exposed to fumes in workplaces where arc welding is performed. Although the number of people diagnosed with pneumoconiosis and its complications has shown a

decreasing trend in recent years in Japan, currently, around 160 workers a year are newly affected²⁾. The percentage of arc welders among this number is high³⁾. Furthermore, the carcinogenic risk of the fumes generated during welding has recently been increased from group 2B to group 1 by the International Agency for Research on Cancer (2017)⁴⁾. Because of this, it is expected that risk management and fume control will become stricter than ever.

The fumes generated during arc welding are solid microparticles in which metal vapor generated from the droplet at the tip of the welding electrode and the welding pool surface rapidly cools and solidifies as it oxidizes⁵⁾. These solid microparticles float in the surrounding air and are inhaled into human body via the mouth and nose.

The particle size of fumes is an important factor that affects the deposition of particles inside the human respiratory system. Since particles with different sizes exhibit

*To whom correspondence should be addressed.

E-mail: j-takahashi@uitech.ac.jp

©2020 National Institute of Occupational Safety and Health

different aerodynamic behavior, they deposit at different locations in the respiratory system. The particle size dependence of the proportions of particles that penetrate and deposit into each location in the respiratory system can be calculated using a model from the International Commission on Radiological Protection⁶⁾. According to this model, the deposition rate peaks at around a particle diameter of 10 μm in entrances to the respiratory system, such as the nose and pharynx. Generally, particles with a diameter on the order of 10 μm or more adhere to the mucosal surfaces of the nasal cavity, trachea, and wide bronchial wall, and are then expelled out of the body⁷⁾. However, fine particles with a diameter of 10 μm or less reach the alveoli of the lungs, and the deposition rate in the alveoli increases as the particle size decreases⁶⁾.

The fumes deposited inside the alveoli become incorporated inside the cells by phagocytosis by alveolar macrophages, and are expelled from the body as sputum by the ciliary motion of the airways together with secretions from inside the airways. However, if the amount of inhaled fumes is large enough to exceed the processing capacity of alveolar macrophages or the ciliary motion is degraded, the alveolar macrophages adhere to the alveoli⁷⁾. This results in lung fibrosis, which causes complications such as pneumoconiosis and primary lung cancer⁸⁾. Currently, in the field of industrial health and safety in Japan, dust with a particle diameter of 4 μm or smaller (aerodynamic diameter), which is the main cause of pneumoconiosis, is defined as respirable dust, and these particles are subject to working environment measurement under the law⁹⁾. Therefore, measurement of the fume particle size distribution and fume generation rate of the arc welding process is important for predicting the hazardousness of fumes and implementing suitable protective measures.

Although arc welding is mainly used with mild steel, it can also be applied to the joining of various metal materials such as stainless steel and aluminum alloys. Among these, over 3 million tons of cast iron are produced annually¹⁰⁾. This is virtually the same as the amount of aluminum alloy products produced in Japan¹⁰⁾. Cast iron is the main metal material used in cast products. Casting is a process in which molten cast iron is formed by pouring into molds of various shapes, and since this process is relatively simple, it is suitable for the mass production of large products and complicated shapes. For these reasons, cast products that use cast iron are utilized in a variety of fields, especially in automotive and instrumental parts for various industries. Arc welding is an essential technology for joining these cast iron pieces together and for making

repairs when cast iron products break.

In past studies, the fume particle size distribution and fume generation rate during arc welding of aluminum alloys, stainless steel, and magnesium alloys focusing on mild steel have been measured. For example, Heile and Hill¹¹⁾ measured the fume particle size distribution and fume generation rate during arc welding of aluminum alloys or mild steel using various filler materials. Hewett¹²⁾ measured the particle size distribution in fumes generated during gas metal arc welding (GMAW) and shielded metal arc welding (SMAW) of mild steel and stainless steel. Furthermore, the authors previously measured the fume particle size distribution and fume generation rate during GMAW of aluminum and magnesium alloys¹³⁾. These studies showed that the fume particle size distribution and fume generation rate depend on various conditions, including the welding process, welding conditions (current, voltage), type of filler material, shield gas composition, and base metal. Since these conditions vary widely in actual workplaces, the fume particle size distribution and fume generation rate are also expected to differ. In fact, empirically, welders notice that arc welding of cast iron produces more fumes than welding of mild steel. However, to our knowledge, no previous studies have measured the fume particle size distribution and fume generation rate during arc welding of cast iron.

Although a variety of different types of filler material have been used in arc welding of cast iron, it has been recommended for a long time that a filler material with Ni as the main constituent (approx. 50–100% Ni) be used^{14, 15)}. However, since the fumes (dust containing Ni compounds) that accumulate in the working environment when filler materials that have Ni as the main constituent are used are highly toxic, strict regulations have been imposed on their handling¹⁶⁾. Therefore, since the use of filler material that has Ni as the main constituent may be harmful to health because of Ni dust, it is preferable to use filler materials with a low Ni content or with absolutely no Ni during arc welding of cast iron. We previously proposed an arc welding method for cast iron that uses filler materials, where the main constituents are Fe and Fe-Cr-Ni^{17, 18)}. These welding methods were shown to be economically superior and more practical than filler materials that have Ni as the main constituent.

This research measured the fume particle size distribution and fume generation rate during arc welding of cast iron using filler materials that have Fe and Fe-Cr-Ni as the main constituents, as proposed previously. The generation rate of respirable dust, which is highly hazardous to the

human body, was then estimated from the obtained results. Furthermore, we estimated the generation rate of particles with a particle diameter of $0.3\ \mu\text{m}$ or less, which are considered to be difficult to capture with the filters of dust masks^{19–24}.

Methods

Measurement of particle size distribution

As shown in Fig. 1, generation of the arc was performed within a fume collection chamber to exclude the effect of cross currents on sampling. The generated fumes were partially sampled by a suction nozzle fitted in the front face of the fume collection chamber. The welding was performed by moving the arc in the direction shown in Fig. 1. At this time, the distance between the arc and the suction nozzle was in the range of 450–550 mm (Fig. 2). This is almost the same as the actual distance between the arc and the respiration area of the welder.

A 12-stage Andersen-type low-pressure impactor (model LP-20; Tokyo Dylec Corp., Tokyo, Japan) was used to measure the particle size distribution of the fumes. The particle size ranges in each stage of this impactor were $>12.1\ \mu\text{m}$, $8.5\text{--}12.1\ \mu\text{m}$, $5.7\text{--}8.5\ \mu\text{m}$, $3.9\text{--}5.7\ \mu\text{m}$, $2.5\text{--}3.9\ \mu\text{m}$, $1.25\text{--}2.5\ \mu\text{m}$, $0.76\text{--}1.25\ \mu\text{m}$, $0.52\text{--}0.76\ \mu\text{m}$, $0.33\text{--}0.52\ \mu\text{m}$, $0.22\text{--}0.33\ \mu\text{m}$, $0.13\text{--}0.22\ \mu\text{m}$, and $0.06\text{--}0.13\ \mu\text{m}$. The suction flow rate of the impactor was 20 L/min, and filter paper made from glass fiber (T60A20) with a diameter of

80 mm was fitted onto each stage to capture the generated fumes.

When measuring particle size distribution using an Andersen-type impactor, if the amount of collected particles is small, the effect of the filter weight error on the weight of the particles collected at each stage increases. In addition, if the amount of collected particles is too large, re-scattering of particles occurs, which affects the particle size distribution obtained by the measurement. Therefore, in this study, a preliminary experiment was conducted, and the arc generation time was determined to be 90 s (GMAW) or 60 s (SMAW). The suction time was set to 690 s (GMAW) and 660 s (SMAW), including the arc generation time. After performing suction twice, the filter paper attached to each stage was taken out and their weight was measured. The weight of the filter paper fitted to each stage was measured before and after sampling to an accuracy of 0.01 mg, and the weight (mg) of fumes loaded on each stage was determined.

The welding was performed manually by a welder. The welder introduced the welding torch or electrode holder through an inlet in the front face of the fume collection chamber, and performed bead-on-plate welding of a base metal placed on a work table. Bead-on-plate welding is a method of melting a base metal while feeding the filler material into the molten area of the base metal surface.

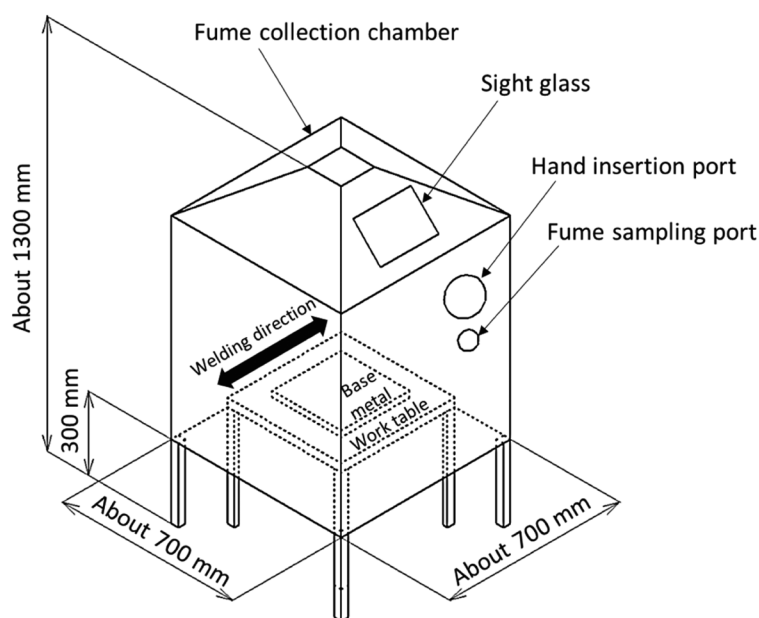

Fig. 1. The fume collection chamber used in this study.

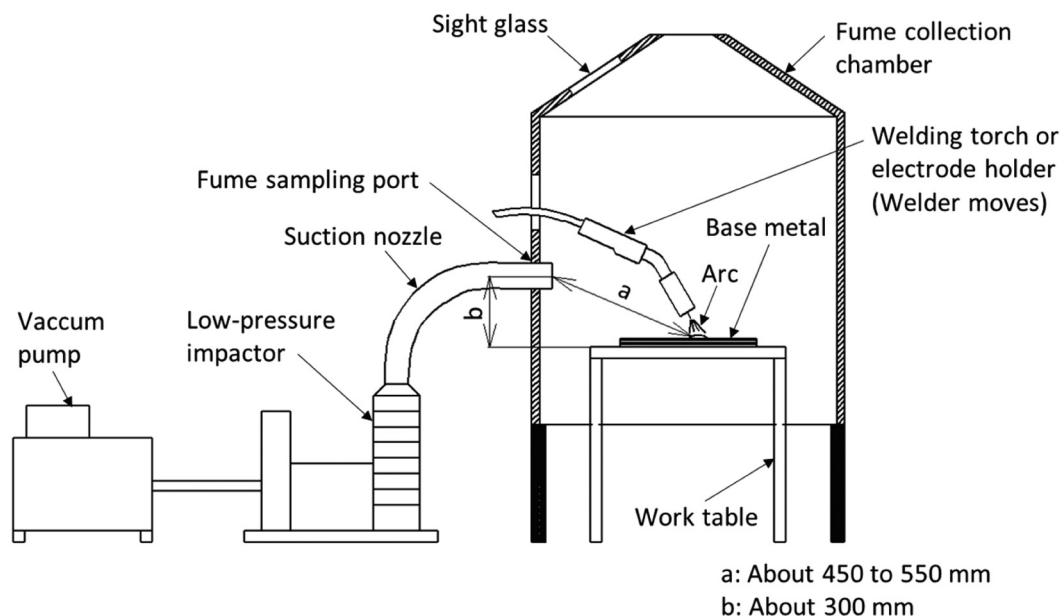

Fig. 2. Experimental setup for measuring the fume particle size distribution.

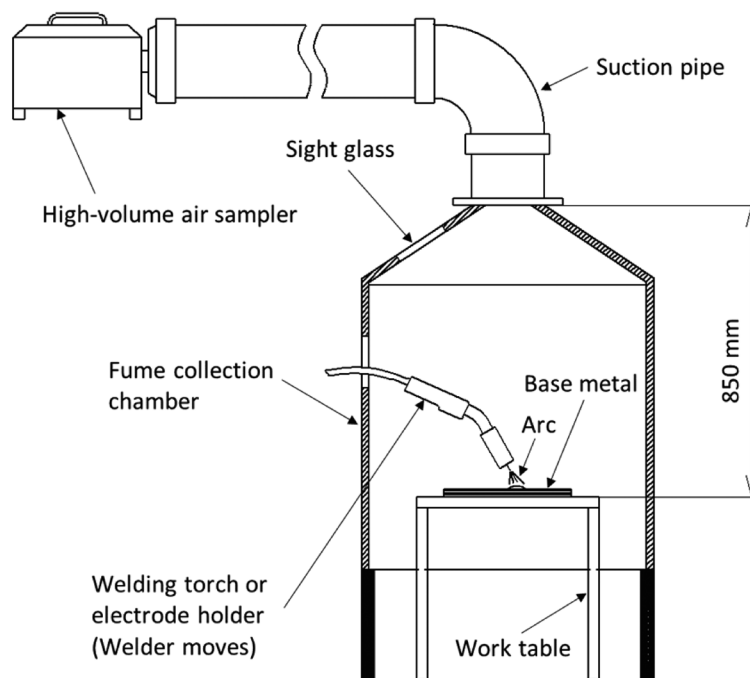

Fig. 3. Experimental setup for measuring the fume generation rate.

Measurement of fume generation rate

The fume generation rate was measured by using a total sampling method that complies with the Japan Industrial Standards (JIS)²⁵. An arc was generated inside the fume collection chamber as shown in Fig. 1, and the fumes were fully collected by a suction pipe fitted at the top of the

fume collecting chamber (Fig. 3). A high-volume air sampler (HV-500F; Shibata Scientific Technology, Saitama, Japan) was used to collect the fumes. After the high-volume air sampler was turned on, the suction rate was set to 800 L/min and the arc was generated immediately. The generated fumes were all collected by filter paper (GB-

Table 1. Chemical compositions of the base metal, welding wires, and covered electrodes (mass%)

Material	C	Si	Mn	P	S	Ni	Cr	Mo	Cu	Mg	Fe
Base metal											
FCD450-10	3.40	2.98	0.20	0.030	0.010	—	—	—	—	0.040	Re.
Filler material											
YGW12 (Mild steel wire)	0.02–0.15	0.50–1.00	1.25–2.00	≤0.030	≤0.030	—	—	—	≤0.50	—	Re.
YS308 (Stainless steel wire)	≤0.08	≤0.65	≤1.0–2.5	≤0.03	≤0.03	9.0–11.0	19.5–22.0	≤0.75	≤0.75	—	Re.
E4916 (Mild steel covered electrode)	≤0.15	≤0.75	≤1.60	≤0.035	≤0.035	≤0.30	≤0.20	≤0.30	—	—	Re.

Re.: remainder.

100R; Advantec Toyo, Kaisha, Ltd., Tokyo, Japan) of 110 mm diameter made from glass fiber fitted in the high-volume air sampler. Next, the fume generation rate (mg/s) was obtained by dividing the weight change in the filter paper before and after collection by the arc generation time.

Equation (1) shows the equation for determining the fume generation rate:

$$F_s = (W_2 - W_1) / T \quad (1)$$

In this equation, F_s is the fume generation rate (mg/s), W_1 is the weight of filter paper before collecting the fumes (mg), W_2 is the weight of filter paper after collecting the fumes (mg), and T is arc generation time (s).

Bead-on-plate welding performed manually by a welder in the same way as during the measurement of the particle size distribution was used for the welding, and the arc generation time was set to 10 s. The suction time of the high-volume air sampler was set to 180 s, including the arc generation time. Bead-on-plate welding was performed in five experimental runs at three different filler materials, and the reported data are the average values from these five sets of experiments.

The base metal used in this research was spheroidal graphite cast iron plate (FCD450-10) as stipulated by the JIS²⁶⁾. The dimensions of the base metal were t18 mm × L300 mm × W300 mm. Table 1 shows the chemical composition of the base metal.

Welding overview

Arc welding is a method of bonding by generating an arc between a metal electrode (filler material) and base metal (metal to be welded), and melting the base metal and filler material using the heat generated at this time. The filler material melted by the heat of the arc forms a weld

reinforcement that ensures the strength of the weld area and fills the gap between the two base metals being joined. In arc welding of cast iron, it has long been recommended to use a filler material with Ni as the main constituent.

The filler material used in this research was welding wire and covered electrode with Fe and Fe-Cr-Ni as the main constituents, which were confirmed to be highly practical in our previous research^{17, 18)}.

The welding wires were YGW12²⁷⁾ and YS308²⁸⁾ as defined by the JIS. The main constituent of YGW12 is Fe, and it does not contain any Ni. This filler material is mainly for welding mild steel, and is hereafter referred to as mild steel wire. The main constituents of YS308 are Fe-Cr-Ni, and the Ni content is around 10%. This filler material is mainly a filler material for welding stainless steel, and is hereafter referred to as stainless steel wire. Both are solid wire with a diameter of 1.2 mm.

The covered electrode was E4916²⁹⁾ as defined by the JIS. The main constituent of E4916 is Fe, and it is a filler material mainly for welding mild steel. Hereafter, this filler material is referred to as mild steel covered electrode. The diameters of the mild steel covered electrodes were 3.2 mm and 5.0 mm depending on the magnitude of the welding current. Table 1 shows the types and chemical compositions of the welding wires and covered electrodes used in this research as defined by the JIS.

The welding methods used in this research were GMAW and SMAW.

GMAW is a welding method that supplies coiled electrodes (welding wire) to welds automatically while using shielding gas to protect the welds. The shield gas used for mild steel wire was 100% CO₂. The flow rate was 15 L/min. Similarly, 98% Ar + 2% O₂ was used for stainless steel wire, and the flow rate was 20 L/min. The welding machine used for GMAW was a digital inverter type pulse MAG welding machine (DP350; DAIHEN Corpora-

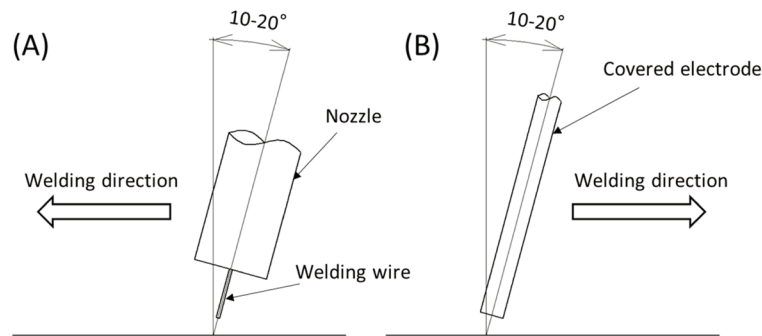

Fig. 4. The welding direction in gas metal arc welding (GMAW) and shielded metal arc welding (SMAW). (A) shows the welding direction of GMAW, and (B) shows the welding direction of SMAW.

Table 2. Welding conditions in arc welding (GMAW and SMAW) of cast iron

Welding methods	GMAW		SMAW
Welding consumables	YGW12-100% CO ₂ (Mild steel wire)	YS308-98% Ar + 2% O ₂ (Stainless steel wire)	E4916 (Mild steel covered electrode)
Electrode diameter (mm)	1.2		3.2, 5.0
Welding current (A)	100, 200		
Welding voltage (V)	19.6, 23.8	16.7, 26.7	23.5, 24.5
Wire feeding speed (m/min)	2.4, 6.0	2.7, 7.5	—
Wire extension (mm)	10–15		—
Shielding gas flow rate (L/min)	15	20	—

GMAW: Gas metal arc welding; SMAW: Shielded metal arc welding.

tion, Osaka, Japan). As shown in Fig. 4 (A), the welder performed bead-on-plate welding with the welding torch tilted at around 10–20° in the opposite direction to that of the welding direction.

The welding current was set to 100 A and 200 A. At this time, the feeding speed of the mild steel wire was 2.4 m/min (100 A) and 6.0 m/min (200 A), and the feeding speed of the stainless steel wire was 2.7 m/min (100 A) and 7.5 m/min (200 A). The welding voltage used was the value corresponding to the welding current as decided by the manufacturer of the welding machine.

SMAW is a welding method that uses a covered electrode with a flux coating around a round metal rod with a diameter of 3.2 to 5.0 mm as the electrode. The welding machine used for SMAW was an AC arc welding machine (YK-250AD2; Panasonic Corp., Osaka, Japan). As shown in Fig. 4 (B), the welder performed bead-on-plate welding while tilting the covered electrode around 10–20° in the welding direction. The welding current was set the same as that for GMAW, to 100 A and 200 A. Table 2 shows the main welding conditions for GMAW and SMAW.

Results

Figure 5 shows the fume particle size distribution measured in this study as a frequency distribution³⁰⁾. *W* on the vertical axis represents the total weight of the particles collected by the impactor, and ΔW represents the weight of the particles collected at each stage of the impactor. The horizontal axis shows the particle size range (aerodynamic diameter) at each stage of the impactor. Furthermore, Fig. 6 shows the fume particle size distribution measured in this study as a cumulative distribution³⁰⁾.

From Fig. 6, the mass median aerodynamic diameter (MMAD) at 100 A was 0.63 μm (mild steel wire), 0.52 μm (stainless steel wire), and 0.77 μm (mild steel covered electrode). At 200 A, the MMAD was 0.88 μm (mild steel wire), 0.72 μm (stainless steel wire), and 0.89 μm (mild steel covered electrode). The MMAD increased with increasing welding current in all conditions. Furthermore, the MMAD of the stainless steel wire was smaller than the other conditions at any current value.

The fumes generated under all of the welding conditions measured in this research contained 73–91% respirable

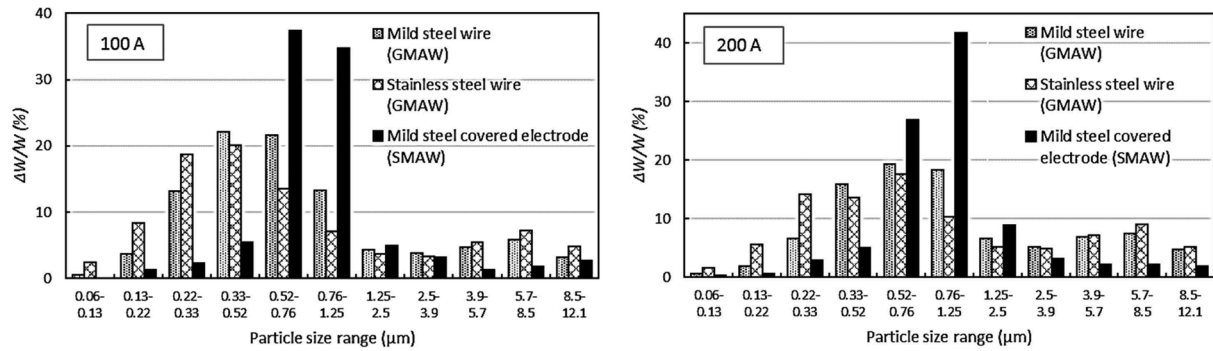

Fig. 5. The fume particle size distribution generated during the arc welding of cast iron. The graph shows the frequency distribution based on weight³⁰. The particle size range indicates the aerodynamic diameter.

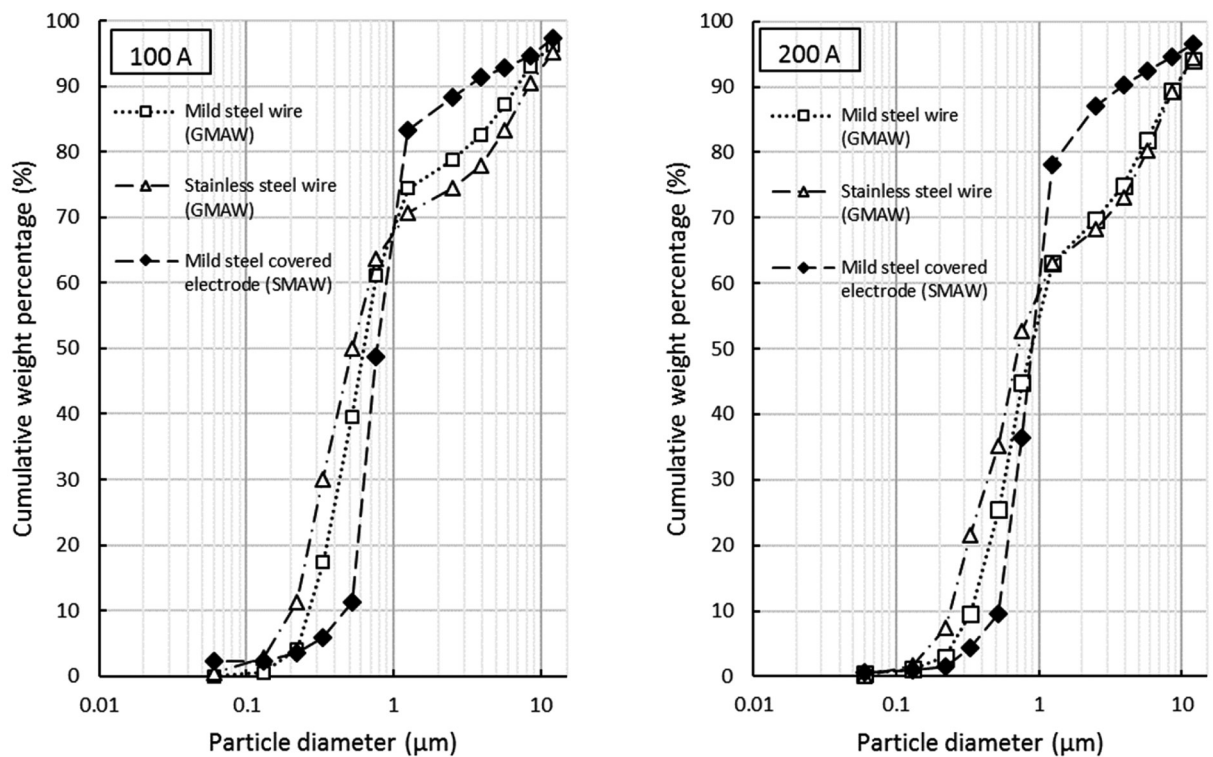

Fig. 6. The fume particle size distribution generated during the arc welding of cast iron. The graph shows the cumulative weight distribution³⁰. The particle diameter indicates the aerodynamic diameter.

dust of particle diameter 4 µm or less, which will deposit on lower respiratory tract, as shown in Fig. 6. The weight percentages of respirable dust was, in order from highest to lowest, mild steel covered electrode, mild steel wire, and stainless steel wire. Furthermore, these weight percentages exhibited a decreasing trend as the welding current increased.

Note that the order of the weight percentages of the particles with diameters of around 1.0 µm or less was the reverse, with the order from highest to lowest being stainless

steel wire, mild steel wire, and mild steel covered electrode.

Figure 7 shows the fume generation rates measured in this research. The fume generation rates measured in this research were in the range of 1.96–12.2 mg/s. The fume generation rates increased as the welding current increased under all conditions. The fume generation rate at 100 A in order from highest to lowest was mild steel covered electrode, mild steel wire, and stainless steel wire, and at 200 A, was stainless steel wire, mild steel covered electrode, and mild steel wire.

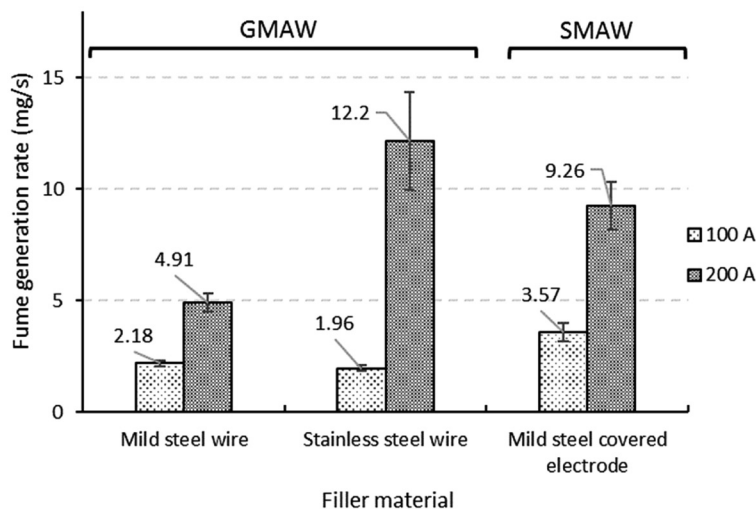

Fig. 7. The fume generation rate measured during the arc welding of cast iron. Error bars represent standard deviations.

Discussion

The fume particle size distribution and fume generation rate during arc welding of cast iron using three different types of filler material with the main constituents of Fe and Fe–Cr–Ni were measured experimentally in this research.

The fumes measured in this research contained 73–91% respirable dust (of particle diameter 4 μm or less) (Fig. 6). This suggests that fumes that are highly hazardous to the human body were generated under all conditions. Therefore, when performing arc welding of cast iron, it is essential to remove the generated fumes, such as by using a local exhaust ventilation system, and for welders to wear appropriate respirators. Furthermore, the fume generation rate increased as the welding current increased, the same as reported in other research^{11, 31)} (Fig. 7).

As shown in Fig. 6, the weight percentages of respirable dust were mild steel covered electrode > mild steel wire > stainless steel wire. Estimating the generation rate of respirable dust by multiplying the weight percentage of respirable dust by the fume generation rate under each condition (weight percentage of respirable dust [%] \times fume generation rate [mg/s]) gives 3.26 mg/s (91.4% \times 3.57 mg/s: mild steel covered electrode), 1.80 mg/s (82.5% \times 2.18 mg/s: mild steel wire), and 1.52 mg/s (77.8% \times 1.96 mg/s: stainless steel wire) at 100 A, and 8.35 mg/s (90.2% \times 9.26 mg/s: mild steel covered electrode), 3.68 mg/s (74.9% \times 4.91 mg/s: mild steel wire), and 8.92 mg/s (73.1% \times 12.2 mg/s: stainless steel wire) at 200 A. This gives a generation rate of respirable dust of mild

steel covered electrode > mild steel wire > stainless steel wire at 100 A, and stainless steel wire > mild steel covered electrode > mild steel wire at 200 A. This shows that the generation rate of respirable dust is higher with a higher fume generation rate.

When the cases of 100 A and 200 A in Fig. 6 are compared, the weight percentage of respirable dust exhibits a decreasing trend as the welding current increases under all conditions. This shows that coarse particles with a diameter of 4 μm or larger contained in the fumes increase as the welding current increases, which matches the results of Ojima³²⁾. However, the generation rate of respirable dust increases by approximately 2 to 6 times as the welding current increases under all conditions. This suggests that the welding current is an important factor that has an effect on the generation rate of respirable dust.

At present, workers who perform arc welding are required to wear respirators in arc welding worksites³³⁾. Above all, particulate respirators are widely used, and for arc welding work, particulate respirators with a performance of category 2 or higher (filtering efficiency of 95% or higher) specified in JIS³⁴⁾ must be used³⁵⁾. However, in general, it is known that particles with a diameter of about 0.1 to 0.3 μm are not easily collected by the filters used in particulate respirators^{19–24)}.

As shown in Fig. 6, the weight percentages of particles with diameters near this (mainly 0.3 μm or less) differ depending on the conditions with stainless steel wire > mild steel wire > mild steel covered electrode. Estimating the generation rate of particles with a diameter of 0.3 μm or

less in the same way as the generation rate of respirable dust gives 0.59 mg/s (stainless steel wire), 0.38 mg/s (mild steel wire), and 0.21 mg/s (mild steel covered electrode) at 100 A, and 2.6 mg/s (stainless steel wire), 0.47 mg/s (mild steel wire), and 0.41 mg/s (mild steel covered electrode) at 200 A. This shows that the generation rate is highest when stainless steel wire is used.

According to the National Institute of Occupational Safety and Health guidelines³⁶⁾, if MMAD is less than 2 μm or is unknown, a high-efficiency particulate air filter (filtering efficiency of 99.97% or higher) or any filter certified to 42 CFR 84³⁷⁾ (filtering efficiency of 95% or higher) should be used. Therefore, when performing arc welding of cast iron using a filler material mainly composed of Fe and Fe-Cr-Ni, a particulate respirator of category 2 or higher specified by JIS³⁴⁾ or powered air purifying respirators specified by JIS³⁸⁾ must be worn. In arc welding operations, particulate respirators of category 2 are commonly used. However, special care must be taken when using stainless steel wire with a high generation rate of particles with a diameter of 0.3 μm or less.

The authors previously measured the fume particle size distribution and fume generation rate during arc welding of mild steel using mild steel wire³⁹⁾. According to this, the fume generation rate of mild steel is in the range of 2.13–4.18 mg/s, and no significant difference is found from the fume generation rate of cast iron (2.18–4.91 mg/s) under the same conditions, as measured in this research. However, in the particle size distribution, there is a trend for the weight percentage of particle diameters 2.5 μm and higher to decrease in the case of mild steel fumes. This means that many particles that are coarser than the case of mild steel are contained in the fumes generated during arc welding of cast iron. Therefore, welders may feel that fume plume from cast iron welding is relatively massive.

Conclusion

This research measured the fume particle size distribution and fume generation rate during arc welding of cast iron by using filler materials with Fe and Fe-Cr-Ni as the main constituents. From these results, we estimated the generation rates of respirable dust and the generation rate of particles with a diameter of 0.3 μm or less. The following conclusions were deduced as a result.

(i) The generation rate of respirable dust increases as the welding current increases (approximately 2 to 6 times). (ii) It is strongly supposed that the higher the fume generation rate, the more respirable dust is generated. (iii) The gen-

eration rate of respirable dust was highest with the mild steel covered electrode at low current and the stainless steel wire at high current. (iv) The generation rate of particles with a diameter of 0.3 μm or less was highest when stainless steel wire was used. (v) Cast iron fumes contain many more coarse particles than mild steel fumes.

References

- 1) Oprya M, Kiro S, Worobiec A, Horemans B, Darchuk L, Novakovic V, Ennan A, Van Grieken R (2012) Size distribution and chemical properties of welding fume of inhalable particles. *J Aerosol Sci* **45**, 50–7. [CrossRef]
- 2) Ministry of Health, Labour and Welfare. Heisei 30nen Gyoumujou shippei hassei joukyou to chousa kekka. <https://www.mhlw.go.jp/content/11300000/000525946.pdf>. Accessed August 9, 2019.
- 3) Kishimoto T (2005) Nihon no jinhai no genjou ni tsuite. *JJOMT* **53**, 54–60 (in Japanese).
- 4) International Agency for Research on Cancer (2018) Welding, molybdenum trioxide, and indium tin oxide. IARC monographs on the evaluation of carcinogenic risks to humans. Volume 118. IARC, Lyon.
- 5) Kobayashi M, Maki S, Hashimoto Y, Suga T (1980) Investigations of fume generating phenomena of shielded metal arc welding. *J Jpn Weld Soc* **49**, 454–61 (in Japanese). [CrossRef]
- 6) International Commission on Radiological Protection (1994) Human respiratory tract model for radiological protection. In: ICRP Publication 66. Ann. ICRP 24, Elsevier Science, Oxford.
- 7) Yoshii C, Morimoto Y, Kido M (2005) Welder's pneumoconiosis—pulmonary disease caused by inhalation of welding fumes. *J Aerosol Res* **20**, 238–42 (in Japanese).
- 8) Morimoto Y (2013) [Pneumoconiosis law and occupational physician]. *J UOEH* **35** Suppl, 113–9 (in Japanese). [Medline] [CrossRef]
- 9) Ministry of Health, Labour and Welfare. Working environment measurement standards, Ministry of Labour notification No. 46. https://www.jniosh.johas.go.jp/icpro/jicosh-old/japanese/country/japan/laws/02_enf/1_metric_std/index.html. Accessed November 1, 2019.
- 10) Research and Statistics Department, Minister's Secretariat (2016) Yearbook of current production statistics: iron and steel, non-ferrous metals, and fabricated metals, Ministry of Economy, Trade, and Industry, Tokyo (in Japanese).
- 11) Heile F, Hill DC (1975) Particulate fume generation in arc welding process. *Weld J* **54**, 201s–10s.
- 12) Hewett P (1995) The particle size distribution, density, and specific surface area of welding fumes from SMAW and GMAW mild and stainless steel consumables. *Am Ind Hyg Assoc J* **56**, 128–35. [Medline] [CrossRef]
- 13) Takahashi J, Nakashima H, Hirabayashi R, Ojima J, Okuno T, Fujii N (2018) Study of fume generated by MIG welding

- of aluminum alloys and magnesium alloy. *J Light Met Weld* **56**, 13–9 (in Japanese).
- 14) Pascual M, Ferrer C, Rayón E (2009) Weldability of spheroidal graphite ductile cast iron using Ni/NiFe electrodes. *Rev Metal* **45**, 334–8. [[CrossRef](#)]
 - 15) Kelly TJ, Bishel RA, Wilson RK (1985) Welding of ductile iron with Ni-Fe-Mn filler metal. *Weld J* **64**, 79–85.
 - 16) Hatano I (2017) Health and safety. *J Jpn Weld Soc* **79**, 508–10 (in Japanese). [[CrossRef](#)]
 - 17) Fujii N, Takahashi J, Suzuki H, Yasuda K (2005) Comparison of strength characteristic of cast iron/mild steel welding joints by various welding processes. *Q J Jpn Weld Soc* **23**, 302–10 (in Japanese). [[CrossRef](#)]
 - 18) Fujii N, Honda H, Fukase A, Yasuda K (2007) Comparison of strength characteristic of nodular graphite cast iron welded joints by various welding processes. *Q J Jpn Weld Soc* **25**, 261–7 (in Japanese). [[CrossRef](#)]
 - 19) Hinds WC (1999) *Aerosol Technology: properties, behavior, and measurement of air borne particles*, 2nd ed. 182–205, John Wiley & Sons, Los Angeles.
 - 20) Martin SB Jr, Moyer ES (2000) Electrostatic respirator filter media: filter efficiency and most penetrating particle size effects. *Appl Occup Environ Hyg* **15**, 609–17. [[Medline](#)] [[CrossRef](#)]
 - 21) Balazy A, Toivola M, Reponen T, Podgórski A, Zimmer A, Grinshpun SA (2006) Manikin-based performance evaluation of N95 filtering-facepiece respirators challenged with nanoparticles. *Ann Occup Hyg* **50**, 259–69. [[Medline](#)]
 - 22) Kim SC, Harrington MS, Pui DYH (2007) Experimental study of nanoparticles penetration through commercial filter media. *J Nanopart Res* **9**, 117–25. [[CrossRef](#)]
 - 23) Eninger RM, Honda T, Reponen T, McKay R, Grinshpun SA (2008) What does respirator certification tell us about filtration of ultrafine particles? *J Occup Environ Hyg* **5**, 286–95. [[Medline](#)] [[CrossRef](#)]
 - 24) Rengasamy S, Eimer BC, Shaffer RE (2009) Comparison of nanoparticle filtration performance of NIOSH-approved and CE-marked particulate filtering facepiece respirators. *Ann Occup Hyg* **53**, 117–28. [[Medline](#)] [[CrossRef](#)]
 - 25) Japanese Industrial Standards Committee (2013) JIS Z 3930: Determination of fume emission rate during arc welding and collection of fume for analysis, Japan Standards Association, Tokyo (in Japanese).
 - 26) Japanese Industrial Standards Committee (2001) JIS G 5502: Spheroidal graphite iron castings, Japan Standards Association, Tokyo (in Japanese).
 - 27) Japanese Industrial Standards Committee (2009) JIS Z 3312: Solid wires for MAG and MIG welding of mild steel, high strength steel and low temperature service steel, Japan Standards Association, Tokyo (in Japanese).
 - 28) Japanese Industrial Standards Committee (2013) JIS Z 3321: Stainless steel rods, wires and strip electrodes for welding, Japan Standards Association, Tokyo (in Japanese).
 - 29) Japanese Industrial Standards Committee (2008) JIS Z 3211: Covered electrodes for mild steel, high tensile strength steel and low temperature service steel, Japan Standards Association, Tokyo (in Japanese).
 - 30) Japanese Industrial Standards Committee (1989) JIS K 0302: Measuring method for particle—size distribution of dust in flue gas, Japan Standards Association, Tokyo (in Japanese).
 - 31) Suga T, Kobayashi M (1984) Fume generation in CO₂ arc welding by solid wire. *J Jpn Weld Soc* **2**, 22–9 (in Japanese).
 - 32) Ojima J (2002) [Measuring the calibration factor of a light scattering dust monitor for CO₂ arc welding fumes]. *J UOEH* **24**, 439–44 (in Japanese). [[Medline](#)] [[CrossRef](#)]
 - 33) Ministry of Health, Labour and Welfare. Ordinance on prevention of hazards due to dust, Ministry of Labour Ordinance No. 18. https://www.jniosh.johas.go.jp/icpro/jicosh-old/japanese/country/japan/laws/03_rel/13_dust_reg/index.html. Accessed November 1, 2019.
 - 34) Japanese Industrial Standards Committee (2018) JIS T 8151: Particulate respirators, Japan Standards Association, Tokyo (in Japanese).
 - 35) Ministry of Health, Labour and Welfare. Boujin Masuku no sentaku to siyou ni tsuite. Labor Standards Bureau Notification No.0207006. <https://www.jaish.gr.jp/anzen/hor/hombun/hor1-46/hor1-46-4-1-0.htm>. Accessed November 1, 2019.
 - 36) The National Institute of Occupational Safety and Health, NIOSH guide to the selection and use of particulate respirators. <https://www.cdc.gov/niosh/docs/96-101/default.html>. Accessed December 9, 2019.
 - 37) The National Personal Protective Technology Laboratory, 42 CFR Part 84 Respiratory protective devices. <https://www.cdc.gov/niosh/npptl/topics/respirators/pt84abs2.html>. Accessed December 9, 2019.
 - 38) Japanese Industrial Standards Committee (2018) JIS T 8157: Powered air purifying respirator for particulate matter, Japan Standards Association, Tokyo (in Japanese).
 - 39) Takahashi J, Nakashima H, Ojima J, Fujii N (2018) Characteristic of fumes generated during arc welding of cast iron. Preprints of National Meeting of Japan Weld Soc **103**, 418–9 (in Japanese).