

Estimating the Transitional Probabilities of Smoking Stages with Cross-sectional Data and 10-Year Projection for Smoking Behavior in Iranian Adolescents

Ahmad Khosravi, Mohammad Ali Mansournia, Mahmood Mahmoodi, Ali Akbar Pouyan¹, Kourosh Holakouie-Naieni

Department of Epidemiology and Biostatistics, School of Public Health, Tehran University of Medical Sciences, Tehran, Iran, ¹Department of Computer Engineering and Information Technology, Shahrood University of Technology, Shahrood, Iran

Correspondence to:

Dr. Kourosh Holakouie-Naieni, Department of Epidemiology and Biostatistics, School of Public Health, Tehran University of Medical Sciences, Tehran, Iran.
E-mail: holakoik@hotmail.com

How to cite this article: Khosravi A, Mansournia MA, Mahmoodi M, Pouyan AA, Holakouie-Naieni K. Estimating the transitional probabilities of smoking stages with cross-sectional data and 10-year projection for smoking behavior in Iranian adolescents. *Int J Prev Med* 2016;7:101.

ABSTRACT

Background: Cigarette smoking is one of the most important health-related risk factors in terms of morbidity and mortality. In this study, we introduced a new method for deriving the transitional probabilities of smoking stages from a cross-sectional study and simulated a long-term smoking behavior for adolescents.

Methods: In this study in 2010, a total of 4853 high school students were randomly selected and were completed a self-administered questionnaire about cigarette smoking. We used smoothed age- and sex-specific prevalence of smoking stages in a probabilistic discrete event system for estimating of transitional probabilities. A nonhomogenous discrete time Markov chain analysis was used to model the progression of the smoking in 10 years ahead in the same population. The mean age of the students was 15.69 ± 0.73 years (range: 14–19).

Results: The smoothed prevalence proportion of current smoking varies between 3.58 and 26.14%. The age-adjusted odds of initiation in boys is 8.9 (95% confidence interval [CI]: 7.9–10.0) times of the odds of initiation of smoking in girls. Our study predicted that the prevalence proportion of current smokers increased from 7.55% in 2010 to 20.31% (95% CI: 19.44–21.37) for 2019.

Conclusions: The present study showed a moderately but concerning prevalence of current smoking in Iranian adolescents and introduced a novel method for estimation of transitional probabilities from a cross-sectional study. The increasing trend of cigarette use among adolescents indicated the necessity of paying more attention to this group.

Keywords: Adolescents, discrete event system, projection, smoking stages, transitional probability

INTRODUCTION

Cigarette smoking is one of the most important health-related risk factors in terms of morbidity and

This is an open access article distributed under the terms of the Creative Commons Attribution-NonCommercial-ShareAlike 3.0 License, which allows others to remix, tweak, and build upon the work non-commercially, as long as the author is credited and the new creations are licensed under the identical terms.

For reprints contact: reprints@medknow.com

Access this article online

Quick Response Code:



Website: www.ijpvmjournal.net/www.ijpm.ir

DOI:
10.4103/2008-7802.188602

mortality.^[1,2] As the World Health Organization reports, tobacco use is increasing in countries with low and middle income, and in high-income and developed countries, it is slowly declining with a constant slope.^[3] The prevalence of cigarette smoking has decreased among the USA high school students in recent years. Demonstrating a decrease from 15.8% in 2011, in 2014, almost 9.2% of high school students reported that they had smoked cigarettes in the past 30 days.^[4] Recent Iranian studies showed an increase in cigarette smoking among Iranian adolescents between 2002 and 2012.^[5-7]

Due to a large health and economic consequence of cigarette smoking, it is important to delineate the future trends of cigarette smoking proportion among high school students as a high-risk group for transient over smoking stages and starting of smoking.^[5,8] Many of the studies conducted in Iran are cross-sectional and there are not a long-term cohort study for assessing the smoking behavior in adolescents. Considering the lack of information about the future trends of smoking behavior in a large cohort study in Iran, we use a Markov chain model for projection of smoking behavior among an adolescents cohort for 10 years. Our main purpose was to estimate the age-specific transitional probability for never smoker (NS), current smoker (CS), and ex-smoker within a cross-sectional study, and in the second phase, we used these probabilities for long-term smoking behavior projections. Traditionally, such transitional probabilities are estimated by longitudinal studies, but there is some additional information in cross-sectional studies that can allow us to calculate the transitional probabilities. In this study, we introduced a new method for deriving the transitional probabilities of smoking stages from a cross-sectional study.

METHODS

Data

For estimation of age-adjusted 1-year transitional probabilities of smoking stages, we used a cross-sectional data. At first, in 2010, 57 high schools of Tabriz city were randomly selected and 82 boy and 114 girl classes regarding the number of students were randomly selected. The total number of presented students completed a self-administered multiple-choice anonym questionnaire. To determine the reliability of the cigarette smoking stages questionnaire, we administrated it in 154 students twice with a 2-week interval. Intra-class correlation coefficient was found to be 0.929 (confidence interval [CI] 95%: 0.90–0.95). The validity of the algorithm of smoking stages assessment was approved by Mohammadpoorasl *et al.*^[8] This study have been approved by the Ethics Committee of Tabriz University of Medical Sciences.

For estimating the transitional probabilities, we used age- and sex-specific prevalence of smoking stages

from 4853 subjects. The mean age of the students was 15.69 ± 0.73 years (range: 14–19).

The observed changes in smoking stages prevalence after 1 year in the same students were assessed 1 year later (2011). For validation of predictions, we compared the observed smoking stages prevalence for the same students in 2011 with our predicted smoking stages prevalence from the Markov model.

Study tools

In this study, we used less error-prone questions about smoking patterns such as smoking in the past 7 days and past 30 days and when tried a cigarette for the first time or the last time. Students were classified into three stages of cigarette smoking continuum^[4,9-11] as follows: (a) NS: Adolescents who have never smoked (even a puff); (b) CS: Adolescents who have tried the cigarette (even a puff) and smoked in the past 30 days; and (c) ex-smoker (XS): Adolescents who have smoked cigarettes and did not smoked for 30 days ago. Figure 1 shows an algorithm for classifying students into different stages of smoking. As shown in this algorithm, ex-smokers (XS) in each specific age are consisted of three subcategories; (a) NXS = NS who progressed to ex-smoker (students that smoked and quitted in the same age); (b) \overline{XS} CS who progressed to ex-smoker 1 year ago; and (c) XXS = ex-smoker that remained as ex-smoker in the past year.

Estimating of state probability and transitional probability

The state probabilities of smoking were computed by age- and sex-specific prevalence proportions for NS, CS, and ex-smokers. Our approaches for estimating transitional probabilities consist of two steps: (1) Smoothing of age- and sex-specific prevalence of cigarette smoking stages which can remove the noise of proportions, (2) estimating transitional probabilities between smoking stages with a new and detectable approach as probabilistic discrete event systems (PDESs).

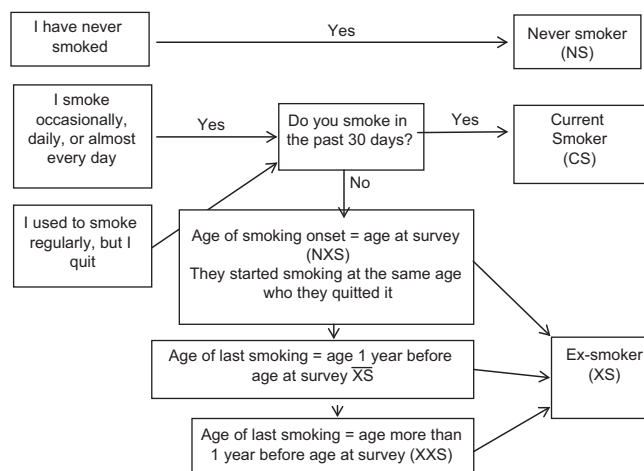

Figure 1: Algorithm for classifying participants into different stages of smoking

According to the classification of smoking behavior, the PDES model is illustrated in Figure 2. The arrowed line in Figure 2 indicates the 7 transition paths. Each σ_i ($i = 1, 2, ,7$) representing the transition from one state to another state during a 1-year period. As shown in Figure 2, σ_1 indicates the probability for an NS remaining as an NS. σ_2 indicates the transitional probability of NS to CS (initiation); σ_4 indicates the transitional probability of CS to an ex-smoker (quitting); σ_5 indicates the transitional probability of ex-smoker to CS (relapsing); σ_7 indicates the transitional probability of NS to ex-smoker (experimenter); σ_3 and σ_6 indicate the probability of CS and ex-smoker remain on their primary stages. To estimate the mentioned transitional probabilities σ_i ($i = 1, 2, 3,7$), we first estimate the smoothed proportion of smoking stages using a multinomial P-splines. The P-spline smoothing can remove the noise from proportions. Fitting P-spline model provides a functional relation between age and prevalence proportions. In consequence, we can calculate CI for proportions.^[12] Given the estimation of transitional probabilities calculated from prevalence proportions of two consecutive ages, removing noise from the data is necessary.^[12]

Projection for smoking behavior

In this study, the smoking progression is assumed to follow a discrete time Markov chain with nonhomogenous transitional probabilities. The probability p_{ij} to move from state s_i to state s_j in one step is named transitional probability. A ten-step sequence from a nonhomogeneous Markov chain was used for simulation of smoking behavior. For projection, we used 5 transition matrix (transition from 14 to 15, 15–16, 16–17, 17–18, and 18–19 years) underlying transitional probabilities as time goes on.^[13] In this method for every student according to the sex and age, a ten-step random sequence was predicted. We assume that a cohort sample of 14–19-year-old students with the starter state at 2011 projected until 2019. We assumed that transitional probability until 19 years is coincident with our predicted transition matrix and in 19–26 years the risk of smoking stages acquiring is constant.

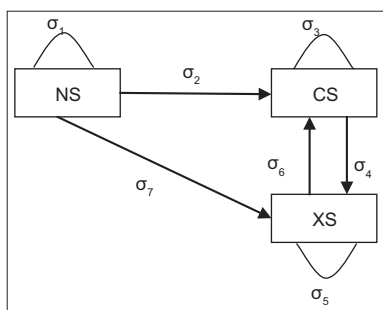

Figure 2: Probabilistic discrete event system model of smoking behavior

Statistical analysis

All calculations were carried out in the statistical software environment R. For fitting a P-spline on multinomial data, we used the codes that written by Kassteele *et al.*^[12] The Markov chain package provides functions for projection the smoking behavior.^[13]

RESULTS

Of the 4853 sample students, 2087 (43%) were boys and 2766 (57%) were girls. Table 1 shows the frequency distribution of the cigarette smoking stages by age and sex. Table 2 shows the smoothed prevalence of the cigarette smoking stages by age. The overall observed prevalence of current smoking among the students was 6.7% (95% CI: 6.0–7.4). The smoothed prevalence proportion of current smoking varies between 3.58 and 26.14%.

Figure 3 shows the multinomial P-spline fit through the observed prevalence proportions of the data. We use the smoothed prevalence of various stages (NS, CS, XS [$\bar{X}S$, XS, NXS]) as the state probabilities. We calculated the sex- and age-specific transitional probabilities from 14 to 19 years in Table 3 using the PDES model. The results of Table 3 indicated that the transitional

Table 1: Frequency distribution of cigarette smoking and quitting stages by age and sex-2010

Age	NS (%)	CS (%)	XS (%)	Total (%)
Boys (years)				
14 and 15	634 (77.3)	56 (6.8)	130 (15.9)	820 (100.0)
16	614 (66.2)	110 (11.8)	204 (22.0)	928 (100.0)
17	136 (52.5)	66 (25.5)	57 (22.0)	259 (100.0)
18 and 19	38 (47.5)	24 (30.0)	18 (22.5)	80 (100.0)
Girls (years)				
14 and 15	1138 (88.2)	29 (2.2)	123 (9.5)	1290 (100.0)
16	1160 (87.5)	33 (2.5)	132 (10.0)	1325 (100.0)
17	100 (84.7)	5 (4.2)	13 (11.0)	118 (100.0)
18 and 19	27 (81.8)	2 (6.1)	4 (12.1)	33 (100.0)
Total	3847 (79.3)	325 (6.7)	681 (14.0)	4853 (100.0)

NS=Never smoker, CS=Current smoker

Table 2: The smoothed prevalence of smoking stages in various ages with a multinomial P-spline fitting

Age (year)	95% CI		
	NS	CS	XS
14	84.48 (83.13-85.80)	3.58 (2.97-4.23)	11.94 (10.73-13.23)
15	80.66 (79.5-81.80)	5.56 (4.82-6.22)	13.78 (12.77-14.79)
16	75.82 (74.35-77.28)	8.49 (7.63-9.40)	15.69 (14.41-16.92)
17	69.78 (67.34-72.21)	12.73 (11.24-14.42)	17.49 (15.57-19.54)
18	62.45 (58.83-66.33)	18.56 (15.61-21.92)	18.98 (16.05-22.16)
19	53.97 (48.86-59.51)	26.14 (20.97-31.85)	19.89 (15.97-24.39)

NS=Never smoker, CS=Current smoker, CI=Confidence interval

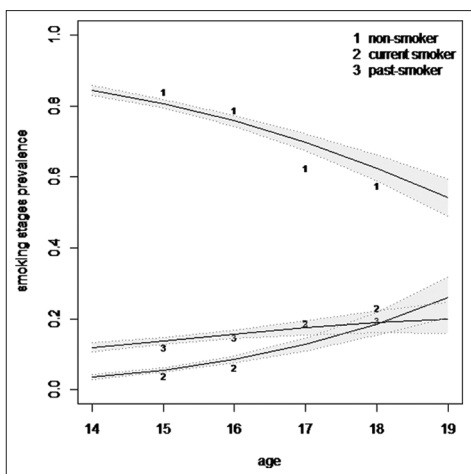

Figure 3: Smoothed prevalence of cigarette smoking and quitting states in adolescents

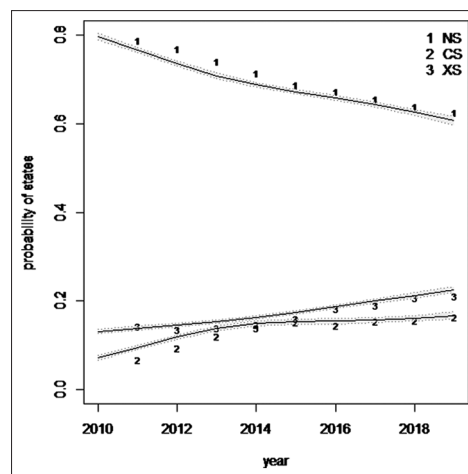

Figure 4: Predicted prevalence of smoking stages for adolescents from 2010 to 2019

probability of NS to CS (initiation) for boys is higher than girls. The age-adjusted odds of initiation in boys is 8.9 (95% CI: 7.9–10.0) times of the odds of initiation in girls. The mean incidence of becoming a CS after 1 year in NS students (initiation) was estimated as 3.5%.

Based the Markov chain model described before, predicted number of students with history of smoking in the past month (CS) and ex-smokers (XS) was projected for 10 years ahead in the same populations [Table 4].

Our study predicted that the prevalence proportion of CSs increased from 7.55% in 2010 to 20.31% (95%CI: 19.44–21.37) for 2019 if the same students have the predicted patterns of smoking. The smoothed 10-year predicted prevalence of smoking stages is illustrated in Figure 4.

Computed results from the Markov chain modeling were compared with 1-year later prevalence of smoking stages from the second phase of the study to assess how accurately the model is predicting the smoking behavior. The result of the second phase (smoking stages prevalence after 1 year in 2011) of this study showed that 74.1% of the participants were NSs (95% CI: 72.8–75.2), 10.7% were CS (95% CI: 9.8–11.6), and 15.1% were ex-smokers (95% CI: 14.1–16.4). For 1-year follow-up, 833 (17.2%) of participants were nonresponse. The comparison of the projected and direct estimated prevalence of current smoking in 2011 indicated that our projection is close but slightly lower than the observed (9.5 vs. 10.7).

DISCUSSION

The probability of a person being in a different stage at 1 year ahead is defined as transitional probability.

Table 3: Estimated transitional probabilities with probabilistic discrete event systems method (%)

Variable	σ_1	σ_2	σ_3	σ_4	σ_5	σ_6	σ_7
Boys							
14	96.45	2.05	67.82	32.18	88.12	11.88	1.50
15	95.45	3.75	67.82	32.18	84.33	15.67	0.80
16	94.22	5.36	69.03	30.97	76.40	23.60	0.41
17	92.80	6.99	71.41	28.59	68.90	31.10	0.20
18	91.26	8.64	73.20	26.80	65.87	34.13	0.10
Girls							
14	99.20	0.46	27.99	72.01	75.69	24.31	0.34
15	99.06	0.46	33.97	66.03	76.42	23.58	0.48
16	98.90	0.55	44.86	55.14	82.55	17.45	0.55
17	98.71	0.70	55.71	44.29	87.49	12.51	0.59
18	98.48	0.95	56.46	34.54	94.10	5.90	0.57

σ_1 =Probability of remaining NS, σ_2 =Probability of progression from NS to CS, σ_3 =Probability of remaining CS, σ_4 =Probability of progression from CS to XS, σ_5 =Progression from XS to CS, σ_6 =Probability of remaining XS, σ_7 =Progression from NS to XS, NS=Never smoker, CS=Current smoker

Table 4: Predicted smoking stages prevalence among adolescent for a 10-year period with a Markov chain model

Years	95% CI		
	NS	CS	XS
2010	79.6 (78.43-79.88)	7.55 (6.94-8.15)	13.29 (12.71-13.84)
2011	76.45 (75.87-77.05)	9.50 (9.09-9.94)	14.05 (13.54-14.53)
2012	73.56 (73.04-74.10)	11.65 (11.23-12.09)	14.79 (14.36-15.19)
2013	70.66 (70.13-71.20)	13.80 (13.30-14.28)	15.54 (15.18-15.90)
2014	67.94 (67.40-68.46)	15.71 (15.20-16.20)	16.36 (16.02-16.68)
2015	65.48 (64.95-66.02)	17.27 (16.74-17.81)	17.25 (16.74-17.81)
2016	63.29 (62.68-63.85)	18.46 (17.91-19.03)	18.25 (17.86-18.64)
2017	61.31 (60.69-61.98)	19.31 (18.74-19.85)	19.35 (18.89-19.84)
2018	59.55 (58.83-60.25)	19.89 (19.27-20.49)	20.56 (19.97-21.18)
2019	57.84 (56.89-58.80)	20.31 (19.44-21.27)	21.86 (21.11-22.64)

NS=Never smoker, CS=Current smoker, CI=Confidence interval

Estimates of transitional probabilities are ideally attained from longitudinal studies, in which cigarette smoking stages are assessed in subjects repeatedly over time. There are also some limitations to cigarette-related longitudinal studies, such as loss to follow-up, inaccuracy of survey time, and repeated survey effect (repeatedly asking a question for several times).^[12,14] Compared to longitudinal study, conducting a cross-sectional study is more cost-effective and collection of data will be easier. There are some ways for extracting the transitional probabilities from repeated cross-sectional data.^[15] There are two new methods for this purpose. The first method is PDES that was introduced in 2010 by Lin *et al.*^[14] and the second method is based on the two steps (smoothing and solving the net transition as a transportation problem).^[12] The base of these methods is that data from a cross-sectional study are analogs to data from a longitudinal survey that follows a sample of birth cohort for multiple years.^[12,14] In our model, we assumed that over time, there is only one path of changes in smoking behavior. In these two methods, under the assumption that transitions remain stable over time, age-specific prevalence data were used for estimations. In this paper, we used a modified PDES model (for the first time introduced in this paper) with seven transitional probabilities. Chen pointed caution when there are sudden and substantial changes in population size.^[10] Findings of this study showed that there are noises in the age-specific prevalence of smoking stages and because of imbalance in the number of students that were sampled, we use a multinomial P-spline method for smoothing of age- and sex-specific prevalence. After the smoothing the age- and sex-specific prevalence of smoking stages, we estimated the transitional probabilities from NS to CS and ex-smoker (σ_1 , σ_2) and CS to ex-smoker (σ_4) and relapsing from ex-smoker to cigarette smoking (σ_6). Comparison of projected and observed prevalence of smoking stages 1 year after the first phase of the study showed that estimation with modified PDES method is close to those computed from the longitudinal study. The validity of this method was evaluated in the other studies.^[10,14]

The overall prevalence of cigarette use among the students was 6.7% (95% CI: 6.0–7.4), and 1-year later in 2011, the observed prevalence of current smoking increased to 10.7 (95% CI: 9.8–11.6). The observed prevalence of the past 30 days cigarette smoking in our study is identical to the study of Shahroud (Northeast of Iran) (7.1% [95% CI: 5–10]).^[16] In another study which was conducted on 1064 male students in Zanjan (Northwest of Iran), almost 23.4% were experimenter and 10.8% were regular smoker.^[17] In a cross-sectional study on 19–25-year-old youngsters of the Isfahan and Najaf-Abad cities, 11.8% of them smoked.^[18] Compared with what has internationally been reported, the prevalence of adolescent cigarette

smoking in our study was considerably small. The prevalence of current smoking in the past 30 days in the USA high school students^[4] has reported to be 9.2%. According to the 2009 National Youth Tobacco Survey, 17.2% (15.0–19.4) of high school students (9th–12 grades) were current cigarette smoker.^[19]

There is evidence that youth are sensitive to nicotine and sooner than adults can feel dependency on nicotine.^[20] The 1-year incidence of becoming a cigarette smoker among nonsmoker adolescents in our study was high (3.5%). The increasing trend of smoking in adolescents is worrying because individuals' behavior and lifestyle are significantly formed during adolescence.

According to the 2010 National Survey on Drug Use and Health, the prevalence of current cigarette smoking among USA young adults (18–25-year-old) was 34.2% (35.3–35.2).^[19] In our study, the projected prevalence of current smoking for young adults (18–24 years) was 15.71% (15.20–16.20) and for ages between 24 and 28 years was 20.31% (19.44–21.27). The increasing trend of cigarette use among adolescents indicated the necessity of paying more attention to this group as the future constructing generation.^[16] Cigarette smoking is a process that begins in adolescence and less older ages, and probability of initiation of smoking grows into a young adult and in older ages either stabilizes or declines with time.^[21] The projected trends of smoking [Figure 4] obviously showed the mentioned pattern for cigarette smoking.

Sampling from grade 10 students and selection of a limited age range for this study violated our observed prevalence proportions despite using quite satisfactory sampling and design. With this limited range, we obtained transitional probability for 5 years consecutive. Hence, our forecasting after 19 can be violated. However, we assumed a constant transitional probability after 19 years. Another limitation of this study was lack of access to longitudinal data with more than two waves for comparison between the predicted and observed smoking stages.

CONCLUSIONS

The result of this study showed a moderate but worrying prevalence of current smoking in Iranian adolescents and introduced a novel method for estimation of transitional probabilities from a cross-sectional study and introduced a Markov chain simulation for projection of smoking behavior for transition from adolescence through young adulthood.

Acknowledgements

We wish to thank all of the students, teachers, and principals of Tabriz high schools for their valuable collaboration.

Financial support and sponsorship

This study was a PhD thesis in Epidemiology supported by Tehran University of Medical Sciences. We would like to thank the Deputy of Research and Technology of Tehran University of Medical Sciences.

Conflicts of interest

There are no conflicts of interest.

Received: 23 Jan 16 **Accepted:** 18 Jul 16

Published: 17 Aug 16

REFERENCES

- Nelson DE, Mowery P, Asman K, Pederson LL, O'Malley PM, Malarcher A, *et al.* Long-term trends in adolescent and young adult smoking in the United States: Metapatterns and implications. *Am J Public Health* 2008;98:905-15.
- Centers for Disease Control and Prevention (CDC). Annual smoking-attributable mortality, years of potential life lost, and productivity losses – United States, 1997-2001. *MMWR Morb Mortal Wkly Rep* 2005;54:625-8.
- Eriksen M, Mackay J, Ross H. *The Tobacco Atlas*. Atlanta: American Cancer Society; 2013.
- Arrazola RA, Singh T, Corey CG, Husten CG, Neff LJ, Apelberg BJ, *et al.* Tobacco use among middle and high school students – United States, 2011-2014. *MMWR Morb Mortal Wkly Rep* 2015;64:381-5.
- Mohammadpoorasl A. Increasing the trend of smoking in Iranian adolescents. *Iran J Public Health* 2013;42:1197-8.
- Heydari G, Sharifi H, Hosseini M, Masjedi MR. Prevalence of smoking among high-school students of Tehran in 2003. *East Mediterr Health J* 2007;13:1017-21.
- Mohammadpoorasl A, Nedjat S, Fakhari A, Yazdani K, Rahimi Foroushani A, Fotouhi A. Smoking stages in an Iranian adolescent population. *Acta Med Iran* 2012;50:746-54.
- Mohammadpoorasl A, Nedjat S, Yazdani K, Fakhari A, Foroushani AR, Fotouhi A. An algorithm of smoking stages assessment in adolescents: A validation study using the latent class analysis model. *Int J Prev Med* 2013;4:1304-11.
- Capannesi M, Boshuizen HC, Willemssen MC, van Houwelingen HC. How to obtain long term projections for smoking behaviour: A case study in the Dutch population. *Comput Math Methods Med* 2009;10:155-64.
- Chen X, Lin F. Estimating transitional probabilities with cross-sectional data to assess smoking behavior progression: A validation analysis. *J Biom Biostat* 2012;1:2.
- Ryan H, Troscclair A, Gfroerer J. Adult current smoking: Differences in definitions and prevalence estimates – NHIS and NSDUH, 2008. *J Environ Public Health* 2012;2012:918368.
- Kasstele JV, Hoogenveen RT, Engelfriet PM, Baal PH, Boshuizen HC. Estimating net transition probabilities from cross-sectional data with application to risk factors in chronic disease modeling. *Stat Med* 2012;31:533-43.
- Spedicato G, Signorelli M. The markovchain package: A package for easily handling discrete markov chains in R; 2014. Available from: <https://github.com/spedygiorgio/markovchain>. [Last accessed on 2016 Jul 08].
- Lin F, Chen X. Estimation of transitional probabilities of discrete event systems from cross-sectional survey and its application in tobacco control. *Inf Sci (Ny)* 2010;180:432-40.
- Pelzer B, Eisinga R. Bayesian estimation of transition probabilities from repeated cross sections. *Stat Neerl* 2002;56:23-33.
- Chaman R, Khosravi A, Sajedinejad S, Nazemi S, Fereidoon Mohasseli K, Valizade B, *et al.* Smoking and its related factors among Iranian high school students. *Iran J Psychiatry Behav Sci* 2015;9:e1583.
- Nazarzadeh M, Bidel Z, Ayubi E, Bahrami A, Jafari F, Mohammadpoorasl A, *et al.* Smoking status in Iranian male adolescents: A cross-sectional study and a meta-analysis. *Addict Behav* 2013;38:2214-8.
- Rouhafza H, Sadeghi M, Emami AR. Smoking in youth: Isfahan healthy heart project (IHHP). *Hakim* 2003;6:61-8.
- U.S. Department of Health and Human Services. Preventing Tobacco Use Among Youth and Young Adults: A Report of the Surgeon General. Atlanta: U.S. Department of Health and Human Services, Centers for Disease Control and Prevention, National Center for Chronic Disease Prevention and Health Promotion, Office on Smoking and Health; 2012.
- Chen X, Ren Y, Lin F, MacDonell K, Jiang Y. Exposure to school and community based prevention programs and reductions in cigarette smoking among adolescents in the United States, 2000-08. *Eval Program Plann* 2012;35:321-8.
- Chen K, Kandel DB. The natural history of drug use from adolescence to the mid-thirties in a general population sample. *Am J Public Health* 1995;85:41-7.