

# S $\gamma$ 3 switch sequences function in place of endogenous S $\gamma$ 1 to mediate antibody class switching

Ali A. Zarrin,<sup>1</sup> Peter H. Goff,<sup>1</sup> Kate Senger,<sup>2</sup> and Frederick W. Alt<sup>1</sup>

<sup>1</sup>Howard Hughes Medical Institute, Children's Hospital, Immune Disease Institute, and Department of Genetics, Harvard University Medical School, Boston, MA 02115

<sup>2</sup>Immunology Discovery Group, Genentech Inc., South San Francisco, CA 94080

**Immunoglobulin heavy chain (IgH) class switch recombination (CSR) replaces the initially expressed IgH C $\mu$  exons with a set of downstream IgH constant region (C $_H$ ) exons. Individual sets of C $_H$  exons are flanked upstream by long (1–10-kb) repetitive switch (S) regions, with CSR involving a deletional recombination event between the donor S $\mu$  region and a downstream S region. Targeting CSR to specific S regions might be mediated by S region–specific factors. To test the role of endogenous S region sequences in targeting specific CSR events, we generated mutant B cells in which the endogenous 10-kb S $\gamma$ 1 region was replaced with wild-type (WT) or synthetic 2-kb S $\gamma$ 3 sequences or a synthetic 2-kb S $\gamma$ 1 sequence. We found that both the inserted endogenous and synthetic S $\gamma$ 3 sequences functioned similarly to a size-matched synthetic S $\gamma$ 1 sequence to mediate substantial CSR to IgG1 in mutant B cells activated under conditions that stimulate IgG1 switching in WT B cells. We conclude that S $\gamma$ 3 can function similarly to S $\gamma$ 1 in mediating endogenous CSR to IgG1. The approach that we have developed will facilitate assays for IgH isotype-specific functions of other endogenous S regions.**

## CORRESPONDENCE

Frederick W. Alt:  
alt@enders.tch.harvard.edu

The IgH constant region (C $_H$ ) determines the class and effector functions of immunoglobulins. IgH class switch recombination (CSR) allows activated B cells to switch from production of IgM to other Ig classes, including IgG, IgE, and IgA. In mice, the exons that encode different IgH classes (termed C $_H$  genes) are organized as 5'–VDJ–C $\mu$ –C $\delta$ –C $\gamma$ 3–C $\gamma$ 1–C $\gamma$ 2b–C $\gamma$ 2a–C $\epsilon$ –C $\alpha$ –3' (1). Each C $_H$  gene that undergoes CSR is preceded by 1–10-kb repetitive switch (S) region sequences. CSR involves introduction of double-strand breaks (DSBs) into the donor S $\mu$  region and into an acceptor downstream S region, followed by joining of the donor and acceptor S regions and replacement of C $\mu$  with a downstream C $_H$  gene (1). CSR requires activation-induced cytidine deaminase (AID) (2), a single-strand DNA cytidine deaminase thought to initiate CSR by deaminating cytidines in S regions, with resulting mismatches ultimately processed by base

excision and/or mismatch repair pathways to generate DSB intermediates (3). After synapsis, broken donor and acceptor S regions are joined by either classical nonhomologous end-joining or alternative end-joining pathways (4). DSBs generated by the IScel endonuclease can, at least in part, functionally replace S regions to mediate recombinational IgH class switching, suggesting that S regions evolved as optimal AID targets to generate sufficient numbers of DSBs to promote CSR (5). In this context, deletion of S $\mu$  or S $\gamma$ 1, or replacement of S regions with random intronic sequences, greatly reduces or abrogates CSR (6–9).

Mammalian S regions are unusually G rich on the coding strand and are primarily composed of tandem repetitive sequences such as TGGGG, GGGGT, GGGCT, GAGCT, and AGCT, with the distribution of individual repetitive sequences varying among different S regions (1). The length of mouse S regions varies, with the 10-kb S $\gamma$ 1 being the largest. Gene-targeted mutation studies in mice have shown a positive correlation between S region length and the frequency of CSR to individual

A.A. Zarrin's present address is Immunology Discovery Group, Genentech Inc., South San Francisco, CA 94080.

The online version of this article contains supplemental material.

loci (9), correlating with the fact that IgG1, with the longest S region, is the most abundant IgH isotype. Most normal CSR junctions occur within and, occasionally, just beyond the S regions (10).

Individual C<sub>H</sub> genes are organized into transcription units with transcription initiating from an intronic (I) promoter located upstream of each S region (11). In vivo, CSR is stimulated by T cell-dependent and independent antigens, which can be mimicked in vitro by activating B cells with anti-CD40 or bacterial LPS in the presence of cytokines such as IL-4 (1). Different activators and cytokine combinations appear to influence CSR to particular S regions by modulating germline transcription (11). Mechanistically, transcription through an S region may target CSR by generating optimal DNA substrates for AID. In this context, transcription through mammalian S regions, in association with their G-rich top strand, results in the formation of an R loop structure (7, 12, 13) that provides single-strand DNA that can serve as an AID substrate. However, gene targeting experiments have shown that the *Xenopus* S<sub>μ</sub> region, which is not G rich and does not form R loops upon transcription, can functionally replace the mouse S<sub>γ1</sub> region, providing about one quarter of its activity compared with a size-matched S<sub>γ1</sub> region (13). In this context, biochemical experiments have shown that AID can access transcribed substrates that are rich in AGCT motifs but that do not form R loops via a mechanism that involves association with replication protein A (14). In mice, CSR to *Xenopus* S<sub>μ</sub>, targeted in place of S<sub>γ1</sub>, appears to primarily involve a region that is rich in AGCT motifs (13). Overall, these findings support the notion that transcription targets specific CSR events by generating AID substrates in S regions through a mechanism that involves targeting of AID to regions rich in AGCT motifs, and that such access may be further enhanced in mammalian S regions via R loop formation (13).

Various lines of evidence suggested that CSR to certain S regions (S<sub>γ3</sub>, S<sub>γ1</sub>, S<sub>ε</sub>, and S<sub>α</sub>) is mediated by S region-specific factors (15–24). In particular, plasmid-based switch substrates revealed several IgH isotype-specific CSR activities (18, 20). Notably, the recombination on particular switch plasmids (e.g., μ to α substrates) occurred only in lines that underwent CSR within the same endogenous S regions (e.g., μ to α but not μ to γ3). Comparison of switch substrates specific for μ to α and for μ to γ3 implicated S<sub>γ3</sub>- and S<sub>α</sub>-specific CSR factors (18), and similar studies provided evidence for S<sub>γ1</sub>-specific CSR factors (20) (for review see reference 24). In addition, substrate studies showed that a single S<sub>γ3</sub> or S<sub>γ1</sub> consensus repeat (49 bp), respectively, supported specific μ to γ3 or μ to γ1 CSR, suggesting that IgH isotype specificity of CSR can be mediated by a single repeat unit (21). Point mutations of the S<sub>γ3</sub> consensus repeat showed its activity to be dependent on the integrity of an NF-κB binding site (21, 22). In this regard, B cells deficient in the p50 subunit of NF-κB under certain conditions produce γ3 germline transcripts but are greatly impaired for switching from μ to γ3 (15, 19). The NF-κB p50 homodimer binds to

specific motifs within the endogenous S<sub>γ3</sub> (19, 21, 22), and mutation of these motifs within a synthetic S<sub>γ3</sub> abolishes S region-specific CSR, supporting the notion that factor binding to these elements directs CSR to S<sub>γ3</sub> (21). In contrast to transient CSR substrate studies, studies of stably integrated transcribed S region substrates suggested that individual

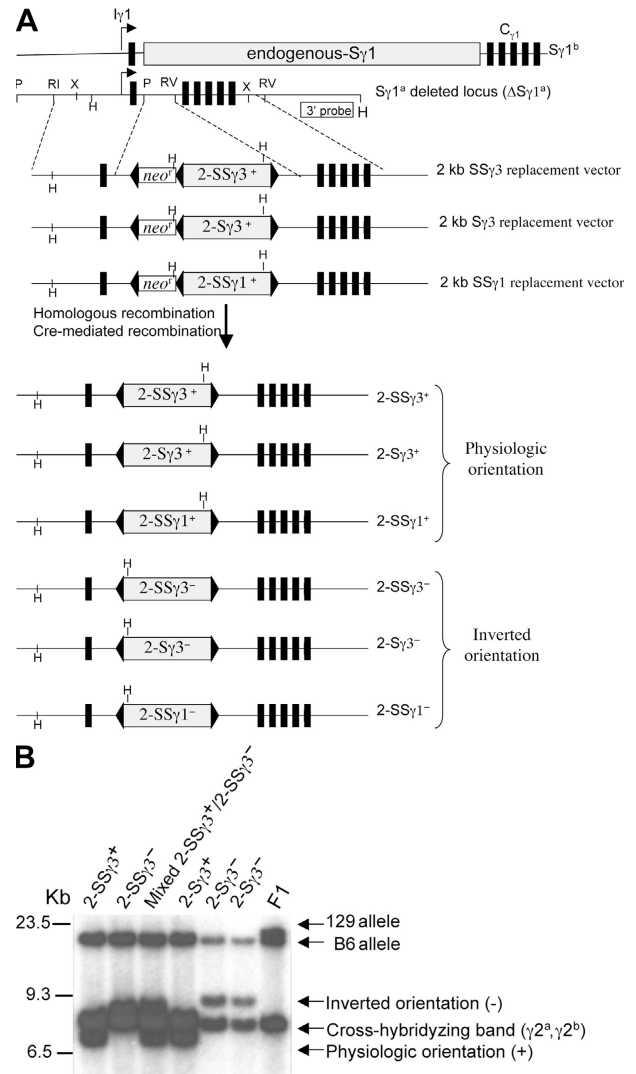

**Figure 1. Targeting and replacement of the S<sub>γ1a</sub> allele.** (A) Genomic organization of S<sub>γ1</sub> (top) and the design of targeting constructs (bottom) are shown. After gene targeting and Cre recombination, the neomycin (neo) gene will be deleted. Inverted loxP sites allow for changing the orientation of different sequences. I<sub>γ1</sub> and C<sub>γ1</sub> are depicted as black rectangles. H, *HindIII*; P, *PstI*; R1, *EcoRI*; RV, *EcoRV*; X, *XbaI*; tri-angles, loxP sites; +, physiological transcriptional orientation; -, inverted transcriptional orientation. (B) Southern blot analyses of genomic DNA digested with *HindIII* and hybridized with a 3' probe. This probe on F1 ES cells detects 20- and 22-kb bands, which represent the endogenous γ1 locus from B6 and 129 alleles, respectively. A crosshybridizing band from the γ2b/γ2a regions is detected with the same probe because of strong sequence homology. The middle sample was a mix of two clones (2-SSγ3) and was not used in the experiments. 2-SSγ1 has been described previously (reference 9).

primary S region sequences may not play a critical role in directing CSR (25).

To generate a physiologically relevant mouse model to test for S region specificity of CSR, we measured the activity of WT or synthetic S $\gamma$ 3 sequences inserted in place of the endogenous S $\gamma$ 1. We find that sized-matched S $\gamma$ 3, synthetic S $\gamma$ 3, and synthetic S $\gamma$ 1 all mediate endogenous CSR, suggesting that the particular sequence of the S region is not a predominant factor in targeting endogenous CSR to IgG1.

## RESULTS AND DISCUSSION

We used our previously established strategy to replace the endogenous 10-kb S $\gamma$ 1<sup>a</sup> region of a  $\gamma$ 1<sup>a</sup>/ $\gamma$ 1<sup>b</sup> F1 embryonic stem (ES) cell line with a 2-kb portion of endogenous S $\gamma$ 3 (2-S $\gamma$ 3), a 2-kb synthetic S $\gamma$ 3 (2-SS $\gamma$ 3), and a 2-kb synthetic S $\gamma$ 1 (2-SS $\gamma$ 1; Fig. 1) (7, 9, 13). For generation of the 2-SS $\gamma$ 3 sequence, we used linkers to concatemerize 40 copies (~2 kb) of the S $\gamma$ 3 consensus sequence (Fig. S1, available at <http://www.jem.org/cgi/content/full/jem.20080451/DC1>). The orientation of tandem repeats in the SS $\gamma$ 3 is unidirectional, therefore mimicking the repeat structure and nucleotide content of the endogenous S $\gamma$ 3 (26). The 2-S $\gamma$ 3 sequence comprises 1946 bp of the endogenous S $\gamma$ 3 region from nucleotides 646 to 2592 (available from GenBank/EMBL/DDBJ under accession no. M12182) (26). This sequence has been previously shown to mediate recombination in transient assays and has been used to assay for S region-specific factors (18, 20). The WT S $\gamma$ 1 repeat is nearly identical to the synthetic S $\gamma$ 1 region and functionally supports CSR in a linear fashion compared with the WT S $\gamma$ 1 sequence (9). The purpose of testing synthetic S $\gamma$ 1 and S $\gamma$ 3 substrates was to determine if this approach would allow endogenous CSR assays of substrates in which the only variables were the few nucleotide differences within each repeat unit and also to be able to test potential functions of candidate motifs within a given S region by generation of synthetic sequences with differing repeat structures.

The F1 ES cell was derived from the hybrid 129Sv-C57BL/6 mice in which the two *IgH* alleles represent the *IgH<sup>a</sup>* (from 129/Sv) or *IgH<sup>b</sup>* (from C57BL/6) allotypes, respectively. The presence of sequence polymorphisms and allotypic markers (antibodies to IgG1<sup>a</sup>) facilitates comparison of the level of CSR on modified alleles to the internal control of the unmodified *IgH<sup>b</sup>* allele. After successful gene targeting, the inserted *neo* cassette was removed by *loxP*/*Cre* recombination (Fig. 1). To analyze the effect of transcription orientation, the two *loxP* sites flanking the insert were placed in inverted orientation, allowing *Cre*-mediated recombination to invert the test sequences. Southern blot analyses were performed to confirm the correct integration of the replaced sequences (Fig. 1 B) (9). The S $\gamma$ 1-replaced mutant F1 ES cells were injected into RAG2-deficient blastocysts to generate chimeric mice to obtain mature B lymphocytes harboring the targeted mutation (27). Splenocytes from mutant and control mice were activated for 2 d with antibody against CD40 (anti-CD40) plus IL-4, a treatment that induces germ-

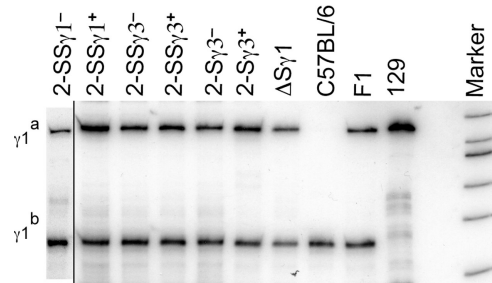
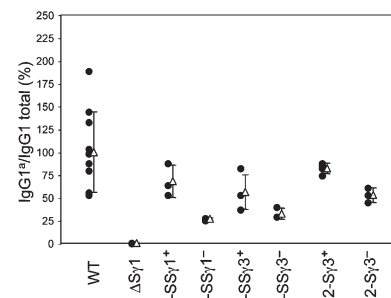

**Figure 2. Germline transcripts from the S $\gamma$ 1 replacement alleles.**

Germline transcripts were RT-PCR amplified via the  $\gamma$ 1 and  $\gamma$ 1 primers and subsequently subjected to primer extension. The final products were digested with *Mbo*I restriction enzyme to distinguish between C57B6 and 129 alleles. Representative data from a minimum of two experiments are shown. The black line indicates that intervening lanes have been spliced out.

line transcription of the *C $\gamma$ 1* gene and CSR to IgG1. Subsequently, we measured the relative levels of steady-state germline transcription from the WT  $\gamma$ 1<sup>b</sup> and targeted  $\gamma$ 1<sup>a</sup> alleles by RT-PCR (Fig. 2) (5, 9, 13). The level of the endogenous  $\gamma$ 1<sup>b</sup> transcript serves as an internal control, and could be distinguished by an *Mbo*I restriction site polymorphism only present in the C57B6 allele. The SS $\gamma$ 1, S $\gamma$ 3, and SS $\gamma$ 3 replacements generated similar levels of germline transcripts to those from the WT  $\gamma$ 1<sup>b</sup> allele.

Transient studies suggested that S $\gamma$ 3 has the potential to support CSR in B cells stimulated to undergo CSR to S $\gamma$ 1 (21). To compare CSR efficiency of S $\gamma$ 3- or SS $\gamma$ 3-replaced endogenous S $\gamma$ 1 alleles with S $\gamma$ 1 alleles harboring similar lengths of S $\gamma$ 1 repeats, we performed ELISA to quantify IgG1<sup>a</sup> versus total IgG1 in the anti-CD40 plus IL-4 culture supernatants (5, 7, 9, 13). The WT controls were splenic B cells derived from WT F1 ES cells using RAG2-deficient blastocyst complementation. The ratio of IgG1<sup>a</sup> to total IgG1 in WT F1 cells was set at 100% (7). These experiments showed that in anti-CD40 plus IL-4-stimulated B cells, size-matched sequences of SS $\gamma$ 1, S $\gamma$ 3, or SS $\gamma$ 3 all generated levels of IgG1<sup>a</sup> secretion that ranged from 25–50% of those of WT



**Figure 3. ELISA on anti-CD40/IL-4-stimulated splenocytes.** The ratio of IgG1<sup>a</sup>/IgG1 total of the WT-S $\gamma$ 1 mice is set as 100% for the IgG1<sup>a</sup> allele. Data from WT and 2-SS $\gamma$ 1 were adopted from a previous study (reference 9). Physiological (+) and inverted (–) orientations of each sequence were obtained by *Cre*/*loxP*. Error bars represent the standard deviation of the mean (triangles).

**Table I.** Ratio of IgG1<sup>a</sup>/IgG1<sup>b</sup> in hybridomas

Genotype	IgG1 <sup>a</sup> /IgG1 <sup>b</sup>	CSR (%)
WT-S $\gamma$ 1	63:42	100
$\Delta$ S $\gamma$ 1	0:160	0
2-SS $\gamma$ 1 <sup>+</sup>	38:81	31
2-SS $\gamma$ 1 <sup>-</sup>	16:112	9
2-SS $\gamma$ 3 <sup>+</sup>	43:94	30
2-SS $\gamma$ 3 <sup>-</sup>	12:96	8
2-S $\gamma$ 3 <sup>+</sup>	52:72	47
2-S $\gamma$ 3 <sup>-</sup>	6:30	13

The numbers of IgG1<sup>a</sup> or IgG1<sup>b</sup> are indicated. Relative CSR frequency is defined by the ratio of IgG1<sup>a</sup>- to IgG1<sup>b</sup>-producing hybridomas and is arbitrarily set as 100% for F1 cells (see Materials and methods). The data for WT and 2-SS $\gamma$ 1 were adopted from our previous study (reference 9).

alleles (Fig. 3). On the other hand, stimulation of 2-S $\gamma$ 3 splenocytes for up to 6 d by treatment with LPS, conditions that normally induce germline C $\gamma$ 3 gene transcription and IgG3 CSR, did not result in any significant increase in IgG1 production in either WT or mutant B cells (Fig. S2, available at <http://www.jem.org/cgi/content/full/jem.20080451/DC1>), consistent with the fact that the germline  $\gamma$ 1 gene is not transcribed under LPS stimulation conditions.

To quantify CSR at a single-cell level, we generated hybridomas from activated B cells. Hybridomas represent fusions of individual B cells to the myeloma partner cell line. We selected IgG1-producing hybridomas by ELISA and compared the level of IgG1<sup>a</sup> with IgG1<sup>b</sup> to score for recombination efficiency between WT and mutated alleles. The IgH locus is subject to allelic exclusion, and only one of the two IgH alleles in a given B cell is recombined functionally into a V(D)J coding region. Therefore, in an F1 control, half of the activated B cells should produce IgH<sup>a</sup> allotype antibodies, and the other half should produce IgH<sup>b</sup> allotype antibodies. Relative CSR frequency is defined by the ratio of IgG1<sup>a</sup>- to IgG1<sup>b</sup>-producing hybridomas (IgG1<sup>a</sup>/IgG1<sup>b</sup>) and is arbitrarily set as 100% for the F1 control. In these experiments, the WT F1 B cell population stimulated with anti-CD40/IL-4 yielded 63 IgG1<sup>a</sup>- and 42 IgG1<sup>b</sup>-producing hybridomas (Table I). In the absence of S $\gamma$ 1, we did not find any IgG1<sup>a</sup>-producing hybridomas (0 IgG1<sup>a</sup> and 160 IgG1<sup>b</sup> hybridomas), as expected (7). Compared with the control, the relative ratio of IgG1<sup>a</sup>/IgG1<sup>b</sup> hybridomas was 31% in 2-SS $\gamma$ 1, 30% in 2-SS $\gamma$ 3, and 47% in 2-S $\gamma$ 3, respectively. Therefore, the levels of CSR to alleles in which S $\gamma$ 1 sequences were replaced with endogenous or synthetic S $\gamma$ 3 sequences was at least as high as those to alleles in which S $\gamma$ 1 was replaced with synthetic S $\gamma$ 1.

Although the levels of CSR supported by the 2-S $\gamma$ 3 replacement alleles appeared slightly higher in both the ELISA and hybridoma analyses, the differences in the ELISA analyses were not statistically significant. Determining whether or not there is a slight preference for the 2-S $\gamma$ 3 sequences would require further study. However, inversion of each type of

inserted S region sequence clearly resulted in substantially decreased IgH class switching to IgG1<sup>a</sup> (Fig. 3 and Table I), potentially caused by decreased R loop formation in the inverse direction (7, 9, 13). Finally, we used a nested PCR approach to map S $\mu$  to SS $\gamma$ 3 junctions in IgG1<sup>a</sup>-producing hybridomas. Junctions occurred throughout the SS $\gamma$ 3 repeat, similar to WT S $\gamma$ 3 (Fig. S3, available at <http://www.jem.org/cgi/content/full/jem.20080451/DC1>) (10). Although four out of eight junctions (50%) fell into a GAGCT motif surrounded by G nucleotides, further mutational studies on synthetic S regions would be required to identify the motifs that are preferentially targeted during CSR in vivo.

Given the central role of IgH isotype class switching in the humoral immunity, it is of significant interest to identify the mechanisms that contribute to the specificity of this process. Past studies have led to the view that S region-specific factors may be required for targeting CSR to S $\gamma$ 3 versus S $\gamma$ 1, and vice versa (24). In this report, we show that synthetic or WT S $\gamma$ 3, or size-matched S $\gamma$ 1 sequences, when inserted in place of the endogenous S $\gamma$ 1, can mediate roughly similar levels of CSR under B cell activation conditions in which CSR to the endogenous S $\gamma$ 1, but not the endogenous S $\gamma$ 3, is induced. We have previously shown that the *Xenopus* S $\mu$  sequence, when substituted for the mouse S $\gamma$ 1 region, can mediate CSR at substantial levels, even though it is AT rich and lacks the ability to form an R loop structure in vitro (13) and in vivo (Leiber, M., personal communication). Thus, our previous *Xenopus* S $\mu$  replacement study (13) complements our current findings; collectively, these studies strongly indicate that nucleotide sequence differences between S $\gamma$ 1 and other S regions are not likely to be major determinants of endogenous IgG1 CSR targeting. Correspondingly, our current findings support germline transcriptional activation of the S $\gamma$ 1 region as the primary mechanism for targeting CSR to IgG1 (28, 29). In this context, the finding that S $\gamma$ 3 sequences in place of S $\gamma$ 1 sequences do not support CSR to IgG1 under conditions (LPS activation) in which IgG3 CSR is induced would reflect the fact that LPS fails to induce germline transcription of the C $\gamma$ 1 gene promoter. Finally, we note that our approach now can be used to test for potential roles of putative S region-specific factors in mediating specific CSR events to other S regions under other stimulation conditions (21, 24).

## MATERIALS AND METHODS

**Targeting constructs.** To generate synthetic S $\gamma$ 3, the consensus S $\gamma$ 3 (5'-GGATCCGGGGAGCTGGGGTAGGTTGGGAGTGTGGGGACCA-GGCTGGGCAGCTCTGAGATCT-3'; BamHI and BglII sites are underlined; reference 26) was oligomerized by sequential cloning into the BamHI site of S85 vector to generate 2-SS $\gamma$ 3 (Fig. S1). After each cloning step, the insert orientation was confirmed by sequencing and restriction endonuclease digestion. The consensus repeats were confirmed to be unidirectional. The 2-SS $\gamma$ 3 sequence was excised as a NotI and SalI fragment and cloned into the targeting construct previously described (9). The endogenous S $\gamma$ 3 region was excised as a BamHI/NotI fragment from pSV5 plasmid (provided by A. Kenter, University of Illinois at Chicago, Chicago, IL) and cloned into pBluescript. Subsequently, the NotI/SalI fragment was ligated into the targeting vector as previously described (9). 2-SS $\gamma$ 1 has been previously described (9).

**Gene targeting, generation of RAG chimeras, and mutant B cells.**

The targeting constructs were transfected into ES cells in which the  $Sy1^a$  was deleted (7). The targeted ES cells were identified by Southern blotting as described in Fig. 1 B (13). The deletion of the *neo'* gene was achieved by infecting ES cells with cre-expressing adenovirus. Targeted ES cells were subcloned and injected into RAG2-deficient blastocysts to produce mature lymphocytes that all harbored the mutant allele (27). Splenic B cells from 6–8-wk-old chimeras were used in our experiments. Mouse protocols were approved by the Institutional Animal Care and Use Committee of Children's Hospital.

**Isotype switching assays.** ELISA and hybridoma analysis were performed as previously described (13). Spleen cells from 6–8-wk-old chimeras were stimulated in vitro with 1  $\mu$ g/ml anti-CD40 (HM40-3; BD Biosciences) plus 25 ng/ml IL-4, or 20  $\mu$ g/ml LPS alone.  $1.5 \times 10^6$  cells were seeded in one well of a sixwell plate ( $0.5 \times 10^6$  cells/ml) in RPMI 1640 media supplemented with 10% FBS, 2 mM glutamine, 100 U/ml penicillin–streptomycin, and 100  $\mu$ M  $\beta$ -mercaptoethanol. Stimulated B cells were used to generate hybridomas (after 4 d) or ELISA (after 6 d), as previously described (7, 13). Monoclonal anti-mouse IgG1<sup>a</sup> (Igh-4a; BD Biosciences) was used to detect IgG1<sup>a</sup> (from the mutated allele). Alkaline phosphatase-conjugated goat anti-mouse IgG1 (SouthernBiotech) was used as the detection antibody. Purified mouse IgG1<sup>a</sup> (BD Biosciences) was used as the standard. Because an antibody specific for IgG1<sup>b</sup> is not available, we normalized the production of IgG1<sup>a</sup> against IgG1 total for ELISA assays on splenic B cell stimulations. The ratio of IgG1<sup>a</sup>/IgG1 total of the WT F1 chimeras was defined as 100% CSR efficiency for the WT  $\gamma 1a$  allele. We measured the ratio of IgG1<sup>a</sup> to IgG1 for different chimeras. Relative CSR efficiency was calculated by the ratio of IgG1<sup>a</sup>- to IgG1<sup>b</sup>-producing hybridomas. Hybridomas that produced only IgG1 and not IgG1<sup>a</sup> were considered to produce IgG1<sup>b</sup>. We defined the numbers of cells that switched  $\gamma 1$  on the a or b allele as  $\gamma 1a$  and  $\gamma 1b$ , respectively, and the numbers of total Ig<sup>+</sup> cells for the two alleles as Ig<sup>a</sup> and Ig<sup>b</sup>, respectively. The switching efficiency to  $\gamma 1$  was given as  $Sa = Sa/Sb = (\gamma 1a/\gamma 1b)/(Ig^a/Ig^b)$ . The ratio of Ig<sup>a</sup>/Ig<sup>b</sup> was determined by the relative ratio of productive V(D)J recombination on the two alleles and was expected to be close to 1. Thus, Ra can be simplified as  $\gamma 1^a/\gamma 1^b$ . After mutation of  $Sy1$ ,  $Ra' = \gamma 1a'/\gamma 1b'$ , and  $Ra'/Ra = (\gamma 1a'/\gamma 1b')/(\gamma 1^a/\gamma 1^b)$  (7). For example, 2-SSy1 produced 38 IgG1<sup>a</sup>-producing and 81 IgG1<sup>b</sup>-producing hybridomas. We normalized this ratio by dividing (38/81) to (63/42 = 1.5) to determine the CSR frequency of the mutated allele (31%).

**CSR junctions.** CSR junctions were amplified from hybridomas by nested PCR (13). Nested mouse  $I\mu$  primers were 5'-CTCTGGCCCTGCT-TATTGTTG-3' followed by 5'-AGACCTGGGAATGTATGGTT-3'. The reverse nested primers were located in exon1 of C $\gamma 1$ , and were 5'-CAATTTTCTTGCCACCTTGCTG-3' followed by 5'-GTG-TGCACACCGCTGGACAGG-3'. PCR products were gel purified and sequenced. S junctions were analyzed with the SeqMan program (DNASar Lasergene) and the MEGABLAST program (National Center for Biotechnology Information; Fig. S3).

**Online supplemental material.** Fig. S1 shows the nucleotide alignment of the synthetic  $Sy3$  and endogenous  $Sy3$ . Fig. S2 shows ELISA of LPS-stimulated splenocytes from 2- $Sy3$ . Fig. S3 provides an analysis of CSR junctions. Online supplemental material is available at <http://www.jem.org/cgi/content/full/jem.20080451/DC1>.

We thank Yuko Fujiwara and Nicole Stokes for generating RAG chimeras and Ming Tian for technical advice. We are grateful to Cherry Lei and Bill Forrest for statistical analyses.

This work was supported by National Institutes of Health grant AI31541 (to F.W. Alt). F.W. Alt is an Investigator of the Howard Hughes Medical Institute.

The authors have no conflicting financial interests.

Submitted: 4 March 2008

Accepted: 30 April 2008

**REFERENCES**

1. Chaudhuri, J., U. Basu, A. Zarrin, C. Yan, S. Franco, T. Perlot, B. Vuong, J. Wang, R.T. Phan, A. Datta, et al. 2007. Evolution of the immunoglobulin heavy chain class switch recombination mechanism. *Adv. Immunol.* 94:157–214.
2. Muramatsu, M., K. Kinoshita, S. Fagarasan, S. Yamada, Y. Shinkai, and T. Honjo. 2000. Class switch recombination and hypermutation require activation-induced cytidine deaminase (AID), a potential RNA editing enzyme. *Cell.* 102:553–563.
3. Di Noia, J.M., and M.S. Neuberger. 2007. Molecular mechanisms of antibody somatic hypermutation. *Annu. Rev. Biochem.* 76:1–22.
4. Yan, C.T., C. Boboila, E.K. Souza, S. Franco, T.R. Hickernell, M. Murphy, S. Gumaste, M. Geyer, A.A. Zarrin, J.P. Manis, et al. 2007. IgH class switching and translocations use a robust non-classical end-joining pathway. *Nature.* 449:478–482.
5. Zarrin, A.A., C. Del Vecchio, E. Tseng, M. Gleason, P. Zarin, M. Tian, and F.W. Alt. 2007. Antibody class switching mediated by yeast endonuclease-generated DNA breaks. *Science.* 315:377–381.
6. Luby, T.M., C.E. Schrader, J. Stavnezer, and E. Selsing. 2001. The  $\mu$  switch region tandem repeats are important, but not required, for antibody class switch recombination. *J. Exp. Med.* 193:159–168.
7. Shinkura, R., M. Tian, M. Smith, K. Chua, Y. Fujiwara, and F.W. Alt. 2003. The influence of transcriptional orientation on endogenous switch region function. *Nat. Immunol.* 4:435–441.
8. Khamlichi, A.A., F. Glaudet, Z. Oruc, V. Denis, M. Le Bert, and M. Cogne. 2004. Immunoglobulin class-switch recombination in mice devoid of any S  $\mu$  tandem repeat. *Blood.* 103:3828–3836.
9. Zarrin, A.A., M. Tian, J. Wang, T. Borjeson, and F.W. Alt. 2005. Influence of switch region length on immunoglobulin class switch recombination. *Proc. Natl. Acad. Sci. USA.* 102:2466–2470.
10. Dunnick, W., G.Z. Hertz, L. Scappino, and C. Gritzmacher. 1993. DNA sequences at immunoglobulin switch region recombination sites. *Nucleic Acids Res.* 21:365–372.
11. Manis, J.P., M. Tian, and F.W. Alt. 2002. Mechanism and control of class-switch recombination. *Trends Immunol.* 23:31–39.
12. Yu, K., F. Chedin, C.L. Hsieh, T.E. Wilson, and M.R. Lieber. 2003. R-loops at immunoglobulin class switch regions in the chromosomes of stimulated B cells. *Nat. Immunol.* 4:442–451.
13. Zarrin, A.A., F.W. Alt, J. Chaudhuri, N. Stokes, D. Kaushal, L. Du Pasquier, and M. Tian. 2004. An evolutionarily conserved target motif for immunoglobulin class-switch recombination. *Nat. Immunol.* 5:1275–1281.
14. Chaudhuri, J., C. Khuong, and F.W. Alt. 2004. Replication protein A interacts with AID to promote deamination of somatic hypermutation targets. *Nature.* 430:992–998.
15. Snapper, C.M., P. Zelazowski, F.R. Rosas, M.R. Kehry, M. Tian, D. Baltimore, and W.C. Sha. 1996. B cells from p50/NF- $\kappa$ B knock-out mice have selective defects in proliferation, differentiation, germ-line CH transcription, and Ig class switching. *J. Immunol.* 156:183–191.
16. Zelazowski, P., D. Carrasco, F.R. Rosas, M.A. Moorman, R. Bravo, and C.M. Snapper. 1997. B cells genetically deficient in the c-Rel trans-activation domain have selective defects in germ-line CH transcription and Ig class switching. *J. Immunol.* 159:3133–3139.
17. Stavnezer, J., S.P. Bradley, N. Rousseau, T. Pearson, A. Shanmugam, D.J. Waite, P.R. Rogers, and A.L. Kenter. 1999. Switch recombination in a transfected plasmid occurs preferentially in a B cell line that undergoes switch recombination of its chromosomal Ig heavy chain genes. *J. Immunol.* 163:2028–2040.
18. Shanmugam, A., M.J. Shi, L. Yauch, J. Stavnezer, and A.L. Kenter. 2000. Evidence for class-specific factors in immunoglobulin isotype switching. *J. Exp. Med.* 191:1365–1380.
19. Wuerffel, R.A., L. Ma, and A.L. Kenter. 2001. NF- $\kappa$ B p50-dependent in vivo footprints at Ig S gamma 3 DNA are correlated with  $\mu \rightarrow \gamma 3$  switch recombination. *J. Immunol.* 166:4552–4559.
20. Ma, L., H.H. Wortis, and A.L. Kenter. 2002. Two new isotype-specific switching activities detected for Ig class switching. *J. Immunol.* 168:2835–2846.
21. Kenter, A.L., R. Wuerffel, C. Dominguez, A. Shanmugam, and H. Zhang. 2004. Mapping of a functional recombination motif that defines

- isotype specificity for  $\mu \rightarrow \gamma 3$  switch recombination implicates NF- $\kappa$ B p50 as the isotype-specific switching factor. *J. Exp. Med.* 199:617–627.
22. Wang, L., R. Wuerffel, and A.L. Kenter. 2006. NF-kappa B binds to the immunoglobulin S gamma 3 region in vivo during class switch recombination. *Eur. J. Immunol.* 36:3315–3323.
  23. Bradley, S.P., D.A. Kaminski, A.H. Peters, T. Jenuwein, and J. Stavnezer. 2006. The histone methyltransferase Suv39h1 increases class switch recombination specifically to IgA. *J. Immunol.* 177:1179–1188.
  24. Stavnezer, J., J.E. Guikema, and C.E. Schrader. 2008. Mechanism and Regulation of Class Switch Recombination. *Annu. Rev. Immunol.* 26:261–292.
  25. Kinoshita, K., J. Tashiro, S. Tomita, C.G. Lee, and T. Honjo. 1998. Target specificity of immunoglobulin class switch recombination is not determined by nucleotide sequences of S regions. *Immunity.* 9:849–858.
  26. Szurek, P., J. Petrini, and W. Dunnick. 1985. Complete nucleotide sequence of the murine gamma 3 switch region and analysis of switch recombination sites in two gamma 3-expressing hybridomas. *J. Immunol.* 135:620–626.
  27. Chen, J., R. Lansford, V. Stewart, F. Young, and F.W. Alt. 1993. RAG-2-deficient blastocyst complementation: an assay of gene function in lymphocyte development. *Proc. Natl. Acad. Sci. USA.* 90:4528–4532.
  28. Stavnezer-Nordgren, J., and S. Sirlin. 1986. Specificity of immunoglobulin heavy chain switch correlates with activity of germline heavy chain genes prior to switching. *EMBO J.* 5:95–102.
  29. Yancopoulos, G.D., R.A. DePinho, K.A. Zimmerman, S.G. Lutzker, N. Rosenberg, and F.W. Alt. 1986. Secondary genomic rearrangement events in pre-B cells: VHDJH replacement by a LINE-1 sequence and directed class switching. *EMBO J.* 5:3259–3266.