

# Alanyl-tRNA Synthetase 1 Gene Variants in Hereditary Neuropathy

## Genotype and Phenotype Overview

Signe Setlere, MD, Marija Jurcenko, MD, Linda Gailite, MD, PhD, Dmitrijs Rots, MD,\* and Viktorija Kenina, MD, PhD\*

### Correspondence

Dr. Setlere  
signe.setlere@gmail.com

*Neurol Genet* 2022;8:e200019. doi:10.1212/NXG.0000000000200019

## Abstract

### Background and Objectives

Our objective was to report 2 novel variants and to reclassify previously reported alanyl-tRNA synthetase 1 (*AARS1*) variants associated with hereditary neuropathy and to summarize the clinical features of a previously published cohort of patients.

### Methods

We performed detailed neurologic and electrophysiologic assessments and segregation analysis of 2 unrelated families with Charcot-Marie-Tooth (CMT) disease with novel variants in the *AARS1* gene. Via literature search, we found studies that included neuropathy cases with *AARS1* variants; we then reviewed and reclassified these variants.

### Results

We identified 2 CMT families harboring previously unreported likely pathogenic *AARS1* variants: c.1823C>A p.(Thr608Lys) and c.1815C>G p.(His605Gln). In addition, we reinterpreted a total of 35 different *AARS1* variants reported in cases with neuropathy from the literature: 9 variants fulfilled the current criteria for being (likely) pathogenic. We compiled and summarized standardized clinical and genotypic information for 90 affected individuals from 32 families with (likely) pathogenic *AARS1* variants. Most experienced motor weakness and sensory loss in the lower limbs.

### Discussion

In total, 11 *AARS1* variants can currently be classified as pathogenic or likely pathogenic and are associated with sensorimotor axonal or intermediate, slowly progressive polyneuropathy with common asymmetry and variable age of symptom onset with no apparent involvement of other organ systems.

\*These authors contributed equally to this work.

Go to [Neurology.org/NG](https://www.neurology.org/NG) for full disclosures. Full information is provided at the end of the article.

The Article Processing Charge was funded by Fundamental and Applied Research Project, Izp-2021/1-0327.

This is an open access article distributed under the terms of the Creative Commons Attribution-NonCommercial-NoDerivatives License 4.0 (CC BY-NC-ND), which permits downloading and sharing the work provided it is properly cited. The work cannot be changed in any way or used commercially without permission from the journal.

## Glossary

**AARS1** = alanyl-tRNA synthetase 1; **ACMG** = American College of Medical Genetics; **AlaRS** = alanyl-transfer RNA; **CMT** = Charcot-Marie-Tooth; **CMTNSv2** = CMT Neuropathy Score version 2; **MNCVs** = motor nerve conduction velocities; **MRC** = Medical Research Council scale; **NCS** = nerve conduction studies; **NCV** = nerve conduction velocity; **VUS** = variants of unknown significance.

Charcot-Marie-Tooth (CMT) disease is a clinically and genetically heterogeneous group of disorders with the phenotype of chronic progressive neuropathy affecting both the motor and the sensory nerves and presenting with progressive distal muscle atrophy and weakness, distal sensory loss, foot deformities, and depressed tendon reflexes. Regarding its worldwide prevalence of an estimated 1:2,500, CMT disease is the most common hereditary neuromuscular disorder.<sup>1,2</sup>

The traditional classification of CMT disease is based on the peripheral neuropathy type, as determined by nerve conduction velocity (NCV) and amplitude of the motor and sensory action potentials in nerve conduction studies (NCS), and the inheritance pattern, as determined by family history. In general, the 3 autosomal dominant neuropathy types based on NCV are as follows: the demyelinating form (CMT1), the axonal form (CMT2), and the intermediate form.<sup>3</sup> A value of 38 m/s for the motor NCV in the median nerve is the most used as the threshold to separate CMT1 and CMT2. Some families present values between 25 and 45 m/s and are considered to have dominant-intermediate forms of CMT disease.<sup>4</sup>

Currently, pathogenic variants in more than 130 genes have been identified as the underlying causes of CMT disease, but only a few of these genes, such as *PMP22*, *GJB1*, *MFN2*, and *MPZ*, account for a significant percentage of CMT cases when variated.<sup>5-8</sup> Pathogenic variants in alanyl-tRNA synthetase 1 (*AARS1*) have been described as the cause of CMT2.

The *AARS1* gene encodes an alanyl-transfer RNA (AlaRS) synthetase enzyme that creates alanyl-aminoacylated tRNA, which is necessary for protein synthesis.<sup>9</sup> Because of its crucial role in cell function, the AlaRS protein is highly conserved among eukaryotes. AlaRS is composed of 3 functional domains: the catalytic, editing, and C-terminal (C-Ala) domains.<sup>10,11</sup>

Pathogenic variants in *AARS1* are rare causes of CMT2, leading to the CMT2N subtype. Currently, neither the genotypic nor the phenotypic spectrum of CMT2N is known, and most of the existing knowledge is based on small case series or case reports. Moreover, some of the variants previously reported as disease causing do not fulfill the current criteria for variant classification. Therefore, to ensure appropriate diagnosis and patient care, there is a need for a comprehensive phenotypic spectrum review and accurate variant reclassification in published cohorts. We sought to describe the clinical and genetic spectrum of CMT2N after reclassification of previously reported and novel *AARS1* variants in

accordance with the currently widely accepted American College of Medical Genetics (ACMG) 2015 variant interpretation guidelines.<sup>12</sup>

In this study, we described 2 novel CMT2N families, each harboring 2 unique previously unreported *AARS1* variants. We further provide a detailed reclassification of 35 previously reported *AARS1* variants associated with hereditary neuropathy and a summary of the clinical features of patients with variants that are classified as likely pathogenic or pathogenic, based on the current ACMG variant classification guidelines.<sup>12</sup>

## Methods

### Identification and Evaluation of Novel Families

In this study, 2 unrelated patients with novel variants in the *AARS1* gene were identified after whole-exome sequencing was performed in a previously published cohort<sup>13</sup> of 96 patients with CMT disease. Both patient families were tested to confirm segregation of the identified variants.

Patients responded to a questionnaire where age at disease onset was determined by inquiring their age at the first appearance of symptoms. Clinical evaluation of motor and sensory functions, deep tendon reflexes, muscle atrophy, and foot deformity was performed. Physical disability was measured by using the CMT Neuropathy Score version 2 (CMTNSv2). Neurophysiologic assessment was performed by using the neurography method with a standard polyneuropathy protocol.

### Literature Search

A search using the Mastermind genomic search engine<sup>14</sup> and the LitVar database,<sup>15</sup> a comprehensive genetic variant database that extracts variant information by text mining from PubMed articles to identify previously published pathogenic *AARS1* variants, was performed on February 6, 2021, using the terms *AARS* and *AARS1*. In addition, information from the HGMD public<sup>16</sup> and the Inherited Neuropathy Consortium variant browser<sup>17</sup> databases was used but failed to identify additional patients, confirming the comprehensiveness of our search. Abstracts were reviewed for all identified manuscripts published since the initial study<sup>18</sup> establishing the pathogenic variant in *AARS1* as the cause of CMT disease. All studies that included *AARS1*-related cases/cohorts of patients with CMT disease and all those involving functional analysis of genetic variants were reviewed in full. Only *AARS1* variants associated with the neuropathy phenotype were

analyzed. Furthermore, data such as genetic variant, segregation within the family, disease phenotype, and electrophysiologic findings were retrieved. Only articles written in English were included in the final analysis.

### Variant Classification

Variant classification and reclassification were performed according to the standards and guidelines for the interpretation of sequence variants published by the ACMG. Variants were annotated using MANE Select v0.93 transcript NM\_001605.3.

### Standard Protocol Approvals, Registrations, and Patient Consents

Written informed consent from all participants was obtained, and the study protocol was approved by the Central Medical Ethics Committee of Latvia (No. 3/18-03-21).

### Data Availability

Anonymized patients' data are available on reasonable request.

## Results

### Clinical Manifestations of CMT Family 1 With the Novel *AARS1* c.1823C>A p.(Thr608Lys) Variant

One patient from the tested CMT cohort<sup>13</sup> had *AARS1* variant c.1823C>A p.(Thr608Lys) (1/III-3). Segregation analysis revealed 1 additional affected family member (his older son, 1/IV-7) (Figure 1). The proband's father and grandmother (1/II-3 and 1/I-3) had walking difficulties but were not available for clinical examination and genetic testing.

The proband (patient 1/III-3), a 39-year-old man, presented with progressive weakness of the lower limbs. He reported walking/running difficulties, the inability to walk on his heels,

bilateral fatigue and weakness in the lower limbs, and pain and a tingling sensation in the left gluteal region and upper thigh during physical activities. At the age of 15 years, he noticed an inability to walk on his heels and instability while running. On neurologic examination, mild atrophy and weakness on foot dorsiflexion and plantar flexion was observed, with a muscle strength score 4 of 5 (Medical Research Council scale [MRC]). Pes cavus and asymmetry of the lower limbs were noted (Figure 2, A and B). Steppage gait was present. Pain sensation and light touch sensation was decreased below the ankle bones in both legs. Vibration sensation of the 4 limbs was unremarkable. Deep tendon reflexes were absent in the lower limbs. Mild amplitude intention tremor of both hands was detected; further examination of the upper limbs was normal. The CMTNSv2 score was 5, which corresponds to mild disease severity. Since the last neurologic evaluation at age 36 years, disease severity and the CMTNSv2 score remained the same.

Patient 1/IV-7 (the proband's 16-year-old son) had experienced progressive exercise intolerance and bilateral knee pain from the age of 10 years. Initially, these symptoms were associated with excessive weight (105 kg; >95th percentile). On physical examination, weakness of the foot extensors on both sides was detected (MRC score 4). The results of a sensory examination were unremarkable. Deep tendon reflexes were absent in the lower limbs. An examination of the upper limbs was normal. The CMTNSv2 score was 3.

### Clinical Manifestations of the CMT Family 2 With the Novel *AARS1* c.1815C>G p.(His605Gln) Variant

CMT cohort<sup>13</sup> analysis revealed a patient with another previously unreported *AARS1* variant, namely c.1815C>G p.(His605Gln) (2/III-2). The proband's sister and sister's daughter (2/III-1 and 2/IV-1, respectively) were also affected and had the same variant (Figure 3). The proband's mother

**Figure 1** Pedigree of Family 1 With *AARS1* Variant c.1823C>A p.(Thr608Lys)

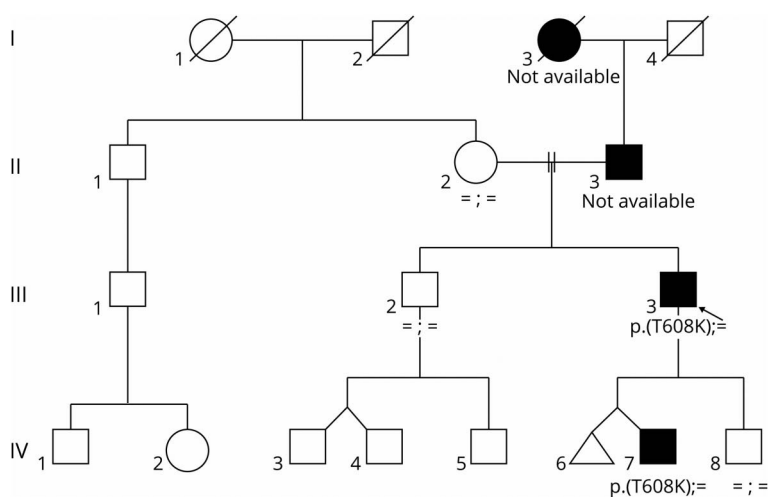

The arrow indicates the proband (patient 1/III-3). The squares and circles represent male and female individuals, respectively, and the closed and open symbols represent affected and unaffected members, respectively.

**Figure 2** Images of Patient 1/III-3 (A and B) and Patient 2/III-1 (C and D) Showing Lower Limb Symptoms Manifesting With Mild Asymmetric Atrophy and Weakness as Well as Pes Cavus



(2/II-5) had walking difficulties but was not available for clinical examination and genetic testing.

The proband (patient 2/III-2), a 59-year-old woman, had progressive weakness of the lower limbs and asymmetric pain in both feet. At the age of 11 years, she was unable to walk on her heels. At the age of 57 years, the patient started to use a unilateral walking aid on the right side. On neurologic examination, marked proximal and distal weaknesses of the lower limbs were detected. Pes cavus and asymmetry of the lower limbs were noted (Figure 2, C and D). Pain sensation and light touch sensation were decreased below the ankle bones in both legs. Vibration sensation and deep tendon

reflexes were absent at the knees and ankles. Further examination of the upper limbs was normal. Since her first neurologic evaluation at the age of 56 years, her CMTNSv2 score had increased from 9 to 14, indicating disease progression from mild to moderate severity.

Patient 2/III-1 (the proband's 57-year-old sister) reported progressive weakness, numbness, tingling sensation, and pain in the lower limbs. Initially, she noticed increased fatigue in her lower extremities during physical activity at 10 years of age. A neurologic examination revealed mild atrophy and weakness in the distal (MRC score 3) and proximal (MRC score 4) muscles of the lower limbs. Pes cavus, asymmetry of

**Figure 3** Pedigree of Family 2 With *AARS1* Variant c.1815C>G p.(His605Gln)

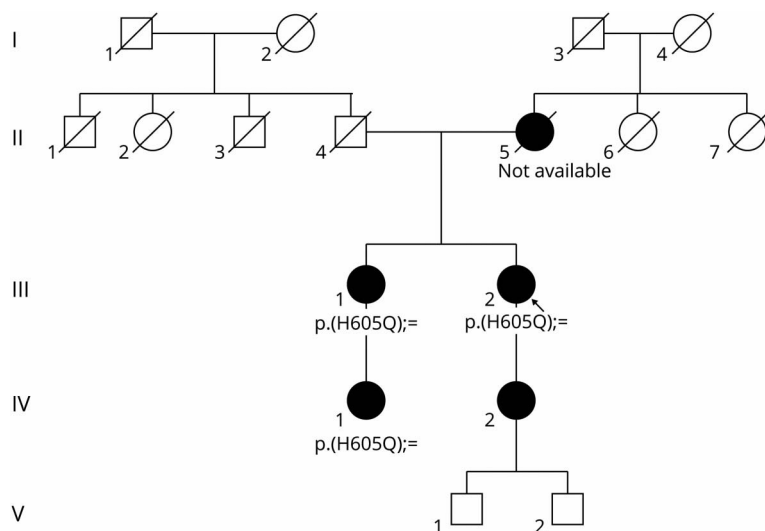

The arrow indicates the proband (patient 2/III-2). The squares and circles represent male and female individuals, respectively, and the closed and open symbols represent affected and unaffected members, respectively.

the lower limbs, and steppage gait were present. An examination of the upper limbs was normal. Pain and light touch sensation were unremarkable in all extremities. Vibration sensation and deep tendon reflexes were absent in the lower limbs. The CMTNSv2 score was 13, which corresponds to moderate disease severity.

Patient 2/IV-1 (17-year-old adolescent girl) reported paraesthesia and pain of the lower limbs during physical activity since 4 years of age. On neurologic examination, muscle strength of all extremities was normal. Sensation was decreased below the ankle bones in both legs. Vibration sensation was decreased at the great toe in both legs. Deep tendon reflexes were absent in the lower limbs. The CMTNSv2 score was 3.

### Electrophysiologic Study

Electrophysiologic studies (eTable 1, [links.lww.com/NXG/A539](https://links.lww.com/NXG/A539)) in all 5 patients showed demyelinating and axonal sensorimotor neuropathy with nerve conduction velocities in the intermediate range in patients 1/III-3, 2/III-2, and 2/III-1. In all patients, NCS revealed abnormal motor nerve conduction velocities (MNCVs) of the median, peroneal, and tibial nerves. Abnormal amplitudes of compound muscle action potentials in the tibial and peroneal nerves were seen in 4/5 (80%) patients. Sensory nerve conduction velocities were mildly below the normal range; however, sensory nerve action potential amplitudes of the median and ulnar nerves were severely impaired in all patients. In summary, 4/5 (80%) patients had axonal damage to the motor nerves of the legs, and all patients had pronounced axonal damage to the sensory nerves of the arms and mild demyelination in the motor and sensory nerves in all extremities. Therefore, the electrophysiologic pattern in patients 1/III-3, 2/III-3, and 2/III-1 fits well with that of the intermediate form of CMT.

### Identification of Studies

The first search identified 3,210 publications. After exclusion of all manuscripts published before the initial study of neuropathy patients with *AARS1* variants<sup>18</sup> in the year 2010, 1,914 publications were retained for abstract review. After filtering, 45 publications reporting patients with neuropathy and *AARS1* variants were included in the final analysis.

### Summary of Variants

A total of 37 different *AARS1* genetic variants originally reported in 122 patients with CMT disease from 61 families, including the 2 novel variants reported in this study, were analyzed (eTable 2, [links.lww.com/NXG/A539](https://links.lww.com/NXG/A539)).<sup>18-32</sup>

We reinterpreted 35 previously reported *AARS1* gene variants in patients with hereditary neuropathy in accordance with the ACMG guidelines: 12 were previously classified as (likely) pathogenic and 23 as variants of unknown significance (VUS).

None of the pathogenic variants, including the most reported recurrent variant p.(Arg329His), were found in gnomAD (v2.1.1 and v3.1), so the pathogenic moderate (PM2) criterion was applied only for variants absent in gnomAD, and for the variants found in gnomAD >1×, the benign strong (BS1) criterion was applied. This resulted in reclassification of 21 variants as benign or likely benign, including the p.(Ala302Thr) and p.(Phe175Leu) variants, which were downgraded from (likely) pathogenic because of the excessively high variant frequency in the gnomAD database (with 169× and 3× alleles of 251,470 among gnomAD exomes, respectively) and lack of segregation information or in vitro functional analysis.

The missense variant p.(Thr608Met) was previously reported in 2 patients with neuropathies.<sup>20,29</sup> This variant was located on the same codon as the novel variant found in family 1

**Figure 4** AARS1 Neuropathy–Associated Variant Localization and Classification

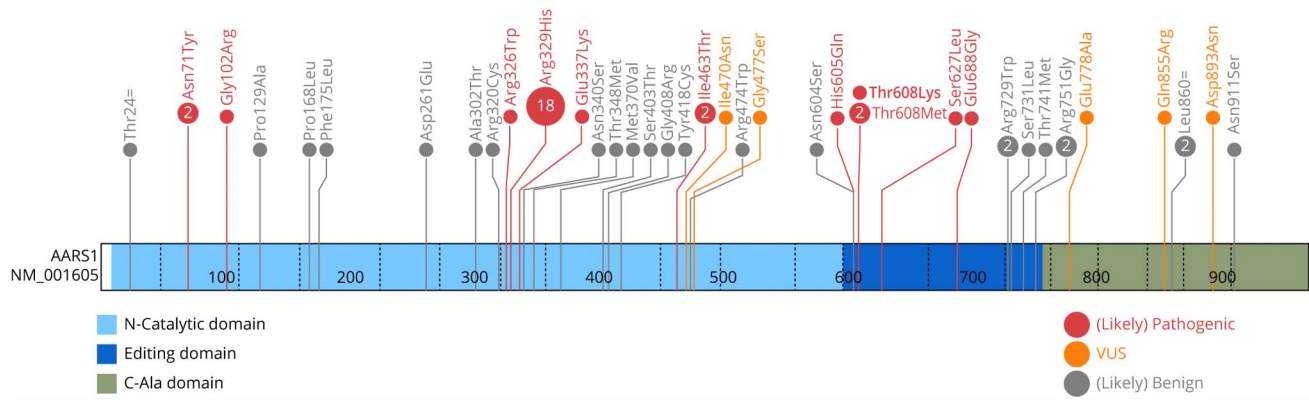

described in this study. This variant was not found in gnomAD and was located in the functional (editing) domain, and multiple in silico tools predicted a pathogenic effect of the variant. Therefore, based on the described evidence, we applied the PS4\_Supporting, PMS\_Supporting, PM2, PM1, and PP3 criteria, respectively, and were able to reclassify this variant from VUS to likely pathogenic.

In summary, of the 12 (likely) pathogenic variants, 2 were downgraded to likely benign and 3 were downgraded to VUS. Of 23 VUS, 2 were reclassified to likely pathogenic p.(Thr608Met) and p.(Ile463Thr), 18 were downgraded to (likely) benign, and 2 are still classified as VUS. In total, 11 variants can be currently classified as pathogenic or likely pathogenic (including the novel variants reported in this study) (eTable 2, [links.lww.com/NXG/A539](https://links.lww.com/NXG/A539)). Our analysis showed that the variants currently classified as pathogenic and likely pathogenic are located only in the N-terminal catalytic domain and the editing domain (Figure 4). The C-ala domain has no (likely) pathogenic variants.

### Clinical Features of AARS1-Related CMT

We compiled standardized clinical and genotypic information for 90 affected individuals from 32 families harboring 11 distinct (likely) pathogenic AARS1 variants from the literature, as well as our reported families. Baseline characteristics and genotypic and clinical features of all patients are summarized in eTable 3, [links.lww.com/NXG/A539](https://links.lww.com/NXG/A539).

For 18/90 (20%) patients, clinical information was not available in the analyzed articles, so we excluded the patients mentioned earlier from further clinical analysis. Although there was some clinical heterogeneity within families, we determined clinical features on a per family basis to reduce distortion of the results. If any individual in the family whose members all shared the same variant was positive for a clinical characteristic, the family was considered positive. In total, the data for 72 patients from 21 families were summarized (Table 1).

The age of the patients varied from 5 to 77 years, and the mean age was 42.5 (SD = 18) years. The mean age of disease

onset was 24 (SD = 15.1) years, and the range was from 0 to 60 years.

The initial symptoms included muscle weakness in the lower and upper extremities, foot drop, walking difficulties, repeated ankle sprains, exercise intolerance cramps and pain in the lower extremities, numbness in the calves and toes, and pes cavus.

Clinical symptoms are summarized in Table 1. Most of them had motor weakness (20/21 [95.2%] families) and sensory loss (21/21 [100%] families) in the lower limbs. Upper limb weakness was present in 14/21 (66.7%) families and sensory impairment in 13/21 (61.9%) families. Foot deformities such as pes cavus and hammer toes were not always assessed but also appeared to be common (13/21 [61.9%] families were reported positive). Asymmetry of muscle weakness and atrophy was outlined in 6/21 (28.6%) families.

Overall, the CMTNS was evaluated in 13 patients. The mean score was 7.2 (SD = 4.6), and the range was from 1 to 14, reflecting mild to moderate severity of impairment among tested patients.

The median nerve MNCVs were obtained in 49 patients from 17 families. Velocities ranged from 11 to 50 m/s (mean = 39.3, SD = 9.7 m/s). Most (28/49, 57.1%) of the patients had a median MNCV greater than 38 m/s or they presented with intermediate nerve conduction velocities (17/49 [34.7%] patients), reflecting the primary axonal involvement or combine effects on both the myelin and the axon. For 3 patients from 2 families, the median nerve MNCV was considered normal. One patient had a median nerve MNCV of 11 m/s; however, the ulnar MNCV was 40 m/s on both sides.<sup>21</sup> Patients with AARS1-related CMT did not display additional systematic features.

## Discussion

In this study, we have reported 2 additional families with novel AARS1 variants, and we also retrospectively analyzed reported

**Table 1** Clinical Symptom Summary and Their Frequency in Patients With Charcot-Marie-Tooth Disease and *AARS1* Pathogenic Variants

Family number	Genetic variant	Motor weakness LL	Motor weakness UL	Sensory loss LL	Sensory loss UL	Reflex loss LL	Reflex loss UL	Foot deformities	Asymmetry
1	c.986G>A p.(Arg329His)	+	+	+	+	+	+	+	+
2	c.986G>A p.(Arg329His)	+	-	-	-	+	-	-	-
3	c.211A>T p.(Asn71Tyr)	+	+	+	+	+	+	-	-
4	c.986G>A p.(Arg329His)	+	NA	NA	NA	NA	NA	+	-
5	c.1823C>T p.(Thr608Met)	-	+	+	+	AS	AS	-	-
6	c.304G>C p.(Gly102Arg)	+	-	+	-	+	+	-	-
7	c.986G>A p.(Arg329His)	+	+	+	+	NA	NA	+	+
8	c.986G>A p.(Arg329His)	+	-	+	-	NA	NA	+	-
9	c.986G>A p.(Arg329His)	+	+	+	+	NA	NA	+	+
10	c.986G>A p.(Arg329His)	+	+	+	+	NA	NA	+	+
11	c.986G>A p.(Arg329His)	+	+	+	-	NA	NA	-	-
12	c.2063A>G p.(Glu688Gly)	+	+	+	+	NA	NA	-	-
13	c.986G>A p.(Arg329His)	+	-	+	+	+	+	-	-
14	c.1880C>T p.(Ser627Leu)	+	+	+	+	+	+	+	-
15	c.1009G>A p.(Glu337Lys)	+	+	+	-	+	-	+	-
16	c.976C>T p.(Arg326Trp)	+	+	+	-	+	+	+	-
17	c.986G>A p.(Arg329His)	+	+	+	+	+	+	+	-
18	c.986G>A p.(Arg329His)	+	+	+	+	NA	NA	-	-
19	c.986G>A p.(Arg329His)	+	+	+	+	+	+	+	-
20	c.1823C>A p.(Thr608Lys)	+	-	+	-	+	+	+	+
21	c.1815C>G p.(His605Gln)	+	-	+	-	+	-	+	+

AS = asymptomatic; LL = lower limbs; NA = not available; UL = upper limbs.

families and reinterpreted *AARS1* variants from previously published hereditary neuropathy patient cohorts, which allowed us to reclassify 35 variants. This endeavor allowed us to determine the clinical and genetic spectrum of the neuropathies caused by (likely) pathogenic variants in *AARS1*.

We determined that only 9/12 (75%) variants previously implicated in CMT disease fulfill the current criteria for being (likely) pathogenic. The available novel evidence (both functional and populational) and analysis of all published *AARS1* variants allowed us not only to downgrade 23 variants but also to reclassify 2 VUS as likely pathogenic. In other recently published studies, the authors have also reclassified a large number of variants by applying the current criteria, although the proportion of variants changing classification varied among the conditions and studies.<sup>33-35</sup> One study reported a reclassification of approximately one-third of the variants in patients with cardiovascular disease.<sup>36</sup> In a different study published in 2020, the authors reclassified rare genetic

variants associated with inherited arrhythmogenic syndromes; the classification for 71.9% of the variants changed.<sup>37</sup> By contrast, another report identified a modification in 14% of genetic variants in children with long QT syndrome.<sup>38</sup> In addition, a recently published reclassification of *DYSF* variants in a large French series of patients with dysferlinopathy revealed changed pathogenicity for 17/176 (9.7%) variants.<sup>39</sup> One of the main reasons for the reclassification is the availability of variant frequencies in large population databases (like gnomAD). Further expansion of such databases could help further reclassify some of the variants. In light of all this evidence, new information on genetic variants may affect the clinical management of patients who have had genetic testing in the past. Although there is currently no consensus as to when and how often variants should be reclassified,<sup>40</sup> variant reclassification in previously published cohorts and work with curators of variant databases to update the information for the erroneously classified variants has become an important task in modern genetics. Moreover, when using information about

previously published variants associated with a condition for variant classification (e.g., to determine mutational hotspots or variants affecting the same codon), their pathogenicity should also be evaluated critically.

This study demonstrated the CMT disease genotypic and phenotypic profiles of 11 different pathogenic variants in *AARS1* by assembling information for previously reported and novel individuals from 32 families. In addition, we have presented 2 novel variants in *AARS1*, c.1823C>A p.(Thr608Lys) and c.1815C>G p.(His605Gln), which we discovered in 2 CMT families from our cohort.<sup>13</sup> Both novel variants are located in the *AARS1* editing domain, similarly to 3 other (likely) pathogenic variants: p.(Ser627Leu), p.(Thr608Met), and p.(Glu688Gly). Six variants (p.(Asn71Tyr), p.(Gly102Arg), p.(Arg326Trp), p.(Arg329His), p.(Ile463Thr), and p.(Glu337Lys)) are located in the catalytic domain. Of interest all 3 previously reported (likely) pathogenic variants located in the C-ala domain—p.(Glu778Ala), p.(Gln855Arg), and p.(Asp893Asn)—were reclassified as VUS. Multiple in vitro functional studies of these variants have shown no effect, including on yeast survival, the catalytic activity assay, or changes in protein conformation, so the benign strong (BS3) criterion was applied to these variants.<sup>11,22,41</sup> In silico prediction tools (REVEL, SIFT and DANN) predicted a benign effect of the variants, and the amino acid positions were poorly conserved among species, so the benign supporting (BP4) criterion was also applied (see eTable 2, links.lww.com/NXG/A539 for details). Sufficient segregation information was available for only one of the variants, p.(Asp893Asn), which was rated as pathogenic moderate (PP1\_Moderate). In summary, only *AARS1* missense variants in the N-catalytic and editing domains are classified as (likely) pathogenic for CMT disease, while there is currently no sufficient evidence to classify any of the reported C-ala variants as pathogenic or likely pathogenic.

In general, *AARS1*-related CMT is associated with CMT2<sup>18</sup>; however, 16 previously reported patients<sup>21,24,26</sup> showed intermediate median MNCV (between 25 and 45 m/s) in NCS, indicating both demyelinating and axonal features (see eTable 3, links.lww.com/NXG/A539 for details). Therefore, the electrophysiologic pattern in these families corresponds to the intermediate form of CMT.<sup>42</sup> In fact, NCS in our families with the novel *AARS1* variants showed a mild demyelination process accompanying axonal dysfunction (median nerve MNCV in patients: 1/III-3 = 38.1 m/s; 1/IV-7 = 48.7 m/s; 2/III-2 = 45.4 m/s; 2/IV-1 = 45.7 m/s; and 2/III-1 = 43.9 m/s), also reflecting the intermediate CMT type. The overall clinical manifestations of our reported patients with the p.(Thr608Lys) and the p.(His605Gln) variants are similar to those previously reported with other variants in *AARS1* for predominant motor symptoms in the distal limbs and axonal-type or intermediatetype peripheral neuropathies according to NCS. Similar asymmetry in the lower limbs appeared in patients with the p.(Arg329His), p.(Ser627Leu), p.(Glu337Lys) and p.(Arg326Trp) variants.<sup>18,21,22,25,26,28</sup> Disease progression in our CMT families is slow. For patient 1/III-3, his CMTNSv2 score at 36 years of age was 5 and remained the same at the 3-year follow-up visit, indicating mild

disease severity and a slow course of progression. Patient 2/III-1 presented her first symptoms at 11 years of age and progressed to moderate disease severity at the age of 59. However, there are no previously published data about the *AARS1*-related course of CMT progression. Overall disease severity was mild to moderate, although it was evaluated in only 13 of 119 patients. Therefore, more studies are needed to describe the natural course of *AARS1*-related CMT. In summary, *AARS1* pathogenic variants result in sensorimotor axonal or intermediate, slowly progressive polyneuropathy with common asymmetry and variable age of symptom onset with no apparent involvement of other organ systems.

In conclusion, in this study, we have summarized and described the genetic and phenotypic spectrum of *AARS1*-related CMT disease based on the analysis of 2 novel families we have identified, as well as previously published CMT families, including only cases with variants classified as pathogenic or likely pathogenic according to the current variant classification guidelines. These findings broaden our knowledge of the genotypic-phenotypic spectrum of CMT disease; moreover, they are useful for developing optimal strategies for variant analysis and the management of patients with *AARS1*-related CMT disease and will aid in further *AARS1* variant classification.

## Study Funding

This research is funded by Latvian Science Council, Project Discovering biomarkers of disease progression and variability in Charcot-Marie-Tooth neuropathy, No lzp-2021/1-0327.

## Disclosure

S. Setlere, M. Jurcenko, L. Gailite, D. Rots, and V. Kenina report no disclosures relevant to the manuscript. Go to Neurology.org/NG for full disclosure.

## Publication History

Received by *Neurology: Genetics* December 22, 2022. Accepted in final form July 1, 2022. Submitted and externally peer reviewed. The handling editor was Margherita Milone, MD, PhD.

## Appendix Authors

Name	Location	Contribution
<b>Signe Setlere, MD</b>	Department of Neurology and Neurosurgery, Children's Clinical University Hospital, Riga, Latvia; Department of Doctoral Studies, Riga Stradins University, Riga, Latvia	Drafting/revision of the article for content, including medical writing for content; major role in the acquisition of data; and analysis or interpretation of data
<b>Marija Jurcenko, MD</b>	Department of Medical Genetics and Prenatal Diagnostics, Children's Clinical University Hospital, Riga, Latvia	Drafting/revision of the article for content, including medical writing for content; analysis or interpretation of data
<b>Linda Gailite, MD, PhD</b>	Scientific Laboratory of Molecular Genetics, Riga Stradins University, Riga, Latvia	Drafting/revision of the article for content, including medical writing for content



## Appendix (continued)

Name	Location	Contribution
<b>Dmitrijs Rots, MD</b>	Scientific Laboratory of Molecular Genetics, Riga Stradins University, Riga, Latvia; Department of human genetics, Radboudumc, Nijmegen, The Netherlands	Drafting/revision of the article for content, including medical writing for content; major role in the acquisition of data; study concept or design; and analysis or interpretation of data
<b>Viktorija Kenina, MD, PhD</b>	Department of Biology and Microbiology, Riga Stradins University, Riga, Latvia; Rare Disease Centre, Riga East Clinical University Hospital, Riga, Latvia	Drafting/revision of the article for content, including medical writing for content; major role in the acquisition of data; study concept or design; and analysis or interpretation of data

## References

- Bird TD. Charcot-marie-Tooth (CMT) hereditary neuropathy overview. In: Adam MP, Ardinger HH, Pagon RA, eds. *GeneReviews*<sup>®</sup>: University of Washington, Seattle; 1998.
- Szigeti K, Lupski JR. Charcot-Marie-Tooth disease. *Eur J Hum Genet*. 2009;17(6):703-710. doi.org/10.1038/ejhg.2009.31.
- Stojkovic T. Hereditary neuropathies: an update. *Rev Neurol (Paris)*. 2016;172(12):775-778. doi.org/10.1016/j.neuro.2016.06.007.
- Berciano J, García A, Gallardo E, et al. Intermediate Charcot-Marie-Tooth disease: an electrophysiological reappraisal and systematic review. *J Neurol*. 2017;264(8):1655-1677. doi: 10.1007/s00415-017-8474-3.
- Saporta ASD, Sottile SL, Miller LJ, Feely SME, Siskind CE, Shy ME. Charcot-Marie-Tooth disease subtypes and genetic testing strategies. *Ann Neurol*. 2011;69(1):22-33. doi.org/10.1002/ana.22166.
- Gess B, Schirmacher A, Boentert M, Young P. Charcot-Marie-Tooth disease: frequency of genetic subtypes in a German neuromuscular center population. *Neuromuscul Disord*. 2013;23(8):647-651. doi.org/10.1016/j.nmd.2013.05.005.
- Fridman V, Bundy B, Reilly MM, et al. CMT subtypes and disease burden in patients enrolled in the Inherited Neuropathies Consortium natural history study: a cross-sectional analysis. *J Neurol Neurosurg Psychiatry*. 2015;86(8):873-878. doi.org/10.1136/jnnp-2014-308826.
- Lee AJ, Nam DE, Choi YJ, Nam SH, Choi BO, Chung KW. Alanyl-tRNA synthetase 1 (AARS1) gene mutation in a family with intermediate Charcot-Marie-Tooth neuropathy. *Genes Genomics*. 2020;42(6):663-672. doi: 10.1007/s13258-020-00933-9.
- Wei N, Zhang Q, Yang XL. Neurodegenerative Charcot-Marie-Tooth disease as a case study to decipher novel functions of aminoacyl-tRNA synthetases. *J Biol Chem*. 2019;294(14):5321-5339. doi: 10.1074/jbc.REV118.002955.
- Sokabe M, Ose T, Nakamura A, et al. The structure of alanyl-tRNA synthetase with editing domain. *Proc Natl Acad Sci U S A*. 2009;106(27):11028-11033. doi: 10.1073/pnas.0904645106.
- Zhang H, Yang XL, Sun L. The uniqueness of AlaRS and its human disease connections. *RNA Biol*. 2021;18:1501-1511. doi: 10.1080/15476286.2020.1861803.
- Richards S, Aziz N, Bale S, et al, ACMG Laboratory Quality Assurance Committee. Standards and guidelines for the interpretation of sequence variants: a joint consensus recommendation of the American College of medical genetics and genomics and the association for molecular pathology. *Genet Med*. 2015;17(5):405-424. doi: 10.1038/gim.2015.30.
- Millere E, Rots D, Simrén J, et al. Plasma neurofilament light chain as a potential biomarker in Charcot-Marie-Tooth disease. *Eur J Neurol*. 2021;28(3):974-981. doi: 10.1111/ene.14689.
- Chunn LM, Nefcy DC, Scouten RW, et al. Mastermind: a comprehensive genomic association search engine for empirical evidence curation and genetic variant interpretation. *Front Genet*. 2020;11:577152. doi: 10.3389/fgene.2020.577152.
- Allot A, Peng Y, Wei CH, Lee K, Phan L, Lu Z. LitVar: a semantic search engine for linking genomic variant data in PubMed and PMC. *Nucleic Acids Res*. 2018;46(W1):W530-W536. doi: 10.1093/nar/gky355.
- Stenson PD, Mort M, Ball EV, et al. The Human Gene Mutation Database: towards a comprehensive repository of inherited mutation data for medical research, genetic diagnosis and next-generation sequencing studies. *Hum Genet*. 2017;136(6):665-677. doi: 10.1007/s00439-017-1779-6.
- Saghira C, Bis DM, Stanek D, et al. Variant pathogenicity evaluation in the community-driven inherited neuropathy variant browser. *Hum Mutat*. 2018;39(5):635-642. doi: 10.1002/humu.23412.
- Latour P, Thauvin-Robinet C, Baudelet-Mery C, et al. A major determinant for binding and aminoacylation of tRNA(AL) in cytoplasmic Alanyl-tRNA synthetase is mutated in dominant axonal Charcot-Marie-Tooth disease. *Am J Hum Genet*. 2010;86(1):77-82.
- Laššuthová P, Šafka Brožková D, Krútová M, et al. Improving diagnosis of inherited peripheral neuropathies through gene panel analysis. *Orphanet J Rare Dis*. 2016;11(1):118. doi: 10.1186/s13023-016-0500-5.
- Volodarsky M, Kerkhof J, Stuart A, et al. Comprehensive genetic sequence and copy number analysis for Charcot-Marie-Tooth disease in a Canadian cohort of 2517 patients. *J Med Genet*. 2021;58(4):284-288. doi: 10.1136/jmedgenet-2019-106641.
- Weterman MAJ, Kuo M, Kenter SB, et al. Hypermorphic and hypomorphic AARS alleles in patients with CMT2N expand clinical and molecular heterogeneities. *Hum Mol Genet*. 2018;27(23):4036-4050.
- McLaughlin HM, Sakaguchi R, Giblin W, et al. A recurrent loss-of-function alanyl-tRNA synthetase (AARS) mutation in patients with Charcot-Marie-Tooth disease type 2N (CMT2N). *Hum Mutat*. 2012;33(1):244-253.
- Lin KP, Soong BW, Yang CC, et al. The mutational spectrum in a cohort of Charcot-Marie-Tooth disease type 2 among the Han Chinese in Taiwan. *PLoS One*. 2011;6(12):e29393.
- Bansagi B, Antoniadis T, Burton-Jones S, et al. Genotype/phenotype correlations in AARS-related neuropathy in a cohort of patients from the United Kingdom and Ireland. *J Neurol*. 2015;262(8):1899-1908.
- Motley WW, Griffin LB, Mademan J, et al. A novel AARS mutation in a family with dominant myeloneuropathy. *Neurology*. 2015;84(20):2040-2047.
- Lee AJ, Nam DE, Choi YJ, Nam SH, Choi BO, Chung KW. Alanyl-tRNA synthetase 1 (AARS1) gene mutation in a family with intermediate Charcot-Marie-Tooth neuropathy. *Genes Genomics*. 2020;42(6):663-672.
- Hsu YH, Lin KP, Guo YC, Tsai YS, Liao YC, Lee YC. Mutation spectrum of Charcot-Marie-Tooth disease among the Han Chinese in Taiwan. *Ann Clin Transl Neurol*. 2019;6(6):1090-1101. doi: 10.1002/acn3.50797.
- Bacquet J, Stojkovic T, Boyer A, et al. Molecular diagnosis of inherited peripheral neuropathies by targeted next-generation sequencing: molecular spectrum delineation. *BMJ Open*. 2018;8(10):e021632. doi: 10.1136/bmjopen-2018-021632.
- Schabhüttl M, Wieland T, Senderek J, et al. Whole-exome sequencing in patients with inherited neuropathies: outcome and challenges. *J Neurol*. 2014;261(5):970-982. doi: 10.1007/s00415-014-7289-8.
- Lousa M, Vázquez-Huarte-Mendicoa C, Gutiérrez AJ, Saavedra P, Navarro B, Tugores A. Genetic epidemiology, demographic, and clinical characteristics of Charcot-Marie-Tooth disease in the island of Gran Canaria (Spain). *J Peripher Nerv Syst*. 2019;24(1):131-138. doi: 10.1111/jns.12299.
- Zhao Z, Hashiguchi A, Hu J, et al. Alanyl-tRNA synthetase mutation in a family with dominant distal hereditary motor neuropathy. *Neurology*. 2012;78(21):1644-1649.
- Khadilkar SV, Patil ND, Kadam ND, Mansukhani KA, Patel BA. Clinico-electrophysiological and genetic overlaps and magnetic resonance imaging findings in Charcot-Marie-Tooth disease: a pilot study from western India. *Ann Indian Acad Neurol*. 2017;20(4):425-429. doi: 10.4103/aiian.AIAN\_316\_17.
- Quiat D, Witkowski L, Zouk H, Daly KP, Roberts AE. Retrospective analysis of clinical genetic testing in pediatric primary dilated cardiomyopathy: testing outcomes and the effects of variant reclassification. *J Am Heart Assoc*. 2020;9(11):e016195. doi: 10.1161/JAHA.120.016195.
- Tsai GJ, Rañola JMO, Smith C, et al. Outcomes of 92 patient-driven family studies for reclassification of variants of uncertain significance. *Genet Med*. 2019;21(6):1435-1442. doi: 10.1038/s41436-018-0335-7.
- Bennett JS, Bernhardt M, McBride KL, et al. Reclassification of variants of uncertain significance in children with inherited arrhythmia syndromes is predicted by clinical factors. *Pediatr Cardiol*. 2019;40(8):1679-1687. doi: 10.1007/s00246-019-02203-2.
- VanDyke RE, Hashimoto S, Morales A, Pyatt RE, Sturm AC. Impact of variant reclassification in the clinical setting of cardiovascular genetics. *J Genet Couns*. 2021;30(2):503-512. doi: 10.1002/jgc4.1336.
- Campuzano O, Sarquella-Brugada G, Fernandez-Falgueras A, et al. Reanalysis and reclassification of rare genetic variants associated with inherited arrhythmogenic syndromes. *EBioMedicine*. 2020;54:102732. doi: 10.1016/j.ebiom.2020.102732.
- Westphal DS, Burkard T, Moscu-Gregor A, Gebauer R, Hessling G, Wolf CM. Reclassification of genetic variants in children with long QT syndrome. *Mol Genet Genomic Med*. 2020;8(9):e1300. doi: 10.1002/mgg3.1300.
- Charnay T, Blanck V, Cerino M, et al. Retrospective analysis and reclassification of DYSF variants in a large French series of dysferlinopathy patients. *Genet Med*. 2021;23(8):1574-1577. doi: 10.1038/s41436-021-01164-3.
- Matthijs G, Dierking A, Schmidtko J. New EuroGentest/ESHG guidelines and a new clinical utility gene card format for NGS-based testing. *Eur J Hum Genet*. 2016;24(1):1. doi: 10.1038/ejhg.2015.229.
- Sun L, Wei N, Kuhle B, et al. CMT2N-causing aminoacylation domain mutants enable Nrp1 interaction with AlaRS. *Proc Natl Acad Sci U S A*. 2021;118(13):e2012898118. doi: 10.1073/pnas.2012898118.
- Berciano J, García A, Gallardo E, et al. Intermediate Charcot-Marie-Tooth disease: an electrophysiological reappraisal and systematic review. *J Neurol*. 2017;264(8):1655-1677. doi: 10.1007/s00415-017-8474-3.