

Free Calcium Increases during Anaphase in Stamen Hair Cells of *Tradescantia*

Peter K. Hepler and Dale A. Callaham

Botany Department, University of Massachusetts, Amherst, Massachusetts 01003

Abstract. Changes in free calcium concentration ([Ca]) have been detected during anaphase in stamen hair cells of *Tradescantia*. Cells have been injected iontophoretically with the calcium sensitive metallochromic dye arsenazo III and changes in differential absorbance have been measured using a spinning wheel microspectrophotometer. The results obtained on single cells progressing from midmetaphase through to cytokinesis show that the free [Ca] first begins to increase after the initial separation of the sister chromosomes marking the onset of anaphase. The in-

crease continues for 10–15 min while the chromosomes move to the poles; thereafter the [Ca] declines with the cell plate appearing about the time that the ion returns to its basal level. The close temporal correlation firstly between the rise in [Ca] and the breakdown of spindle microtubules (MTs) during anaphase and secondly, between the subsequent fall in [Ca] and the emergence of the MT-containing phragmoplast provides evidence consistent with the idea that endogenous fluctuations in [Ca] control the disassembly/assembly of MTs during mitosis.

It is widely assumed that calcium is a regulator of mitosis. Changes in the intracellular free calcium concentration [Ca]ⁱ could modulate a variety of processes, including the assembly/disassembly of microtubules (MTs), the activation of a mechanochemical ATPase, or the stimulation of gel-sol interconversions, that might participate in the control of the formation and/or function of the mitotic apparatus (12, 21). Several different studies, notably those in which the internal and external level of the ion have been experimentally regulated, have led to the idea that the intracellular free [Ca] is low during metaphase and that it becomes elevated during anaphase, possibly at the metaphase/anaphase transition wherein the [Ca] increase may act as a trigger (9, 13, 32, 33).

These indirect studies have been extremely helpful in developing new ideas but it is clear that direct determination of the timing, magnitude, and location of the presumed [Ca] transients is essential for further progress on the problem of ionic control of cell division. During the last few years, investigators using the newly developed fluorescent indicators quin2 and fura-2 have reported the existence of Ca transients that correlate with the events of mitosis in three different cell types: cultured PtK₁ (19) and PtK₂ cells (14, 22), *Lytechinus* embryos (20), and *Haemanthus* endosperm (15). Although the generalization is made that the [Ca] becomes elevated at the onset of anaphase (21), not all the data fit that conclusion and thus it becomes necessary to examine the findings in more detail.

Ca changes during mitosis in PtK cells have received the

most attention, being the subject of studies by two different laboratories. In the initial investigation based on studies of PtK₁ cells loaded with quin2 acetoxymethyl ester (AM) Keith et al. (14) indicated that the [Ca] declined from prophase to anaphase reaching a low point at midanaphase. However, the same laboratory using the free anion of fura-2, which had been loaded by ATP permeabilization, reported that the [Ca] becomes elevated during anaphase (22). Low light level fluorescence imaging showed that the Ca increase occurred in the spindle pole or in a ring around the mitotic apparatus and remained high for several minutes. The marked differences between the results with the two dyes have been ascribed to the relatively poorer spectral characteristics of quin2 relative to fura-2, which required that much higher levels of quin2 be loaded into cells and resulted in severe buffering of the intracellular free Ca. Ratan et al. (22) also provide evidence that ester loading leads to significant compartmentalization of the dye into particulate fractions, further causing the authors to now disregard the results from their earlier study on PtK₂ cells using quin2 AM. Poenie et al. (19) have analyzed fura-2 AM-loaded PtK₁ cells in which they have used suboptimal culture conditions to retard the sequestration of the dye by intracellular compartments. Their results reveal a brief (20 s) spike of Ca close to the time of the metaphase/anaphase transition with the [Ca] returning directly to basal levels for the bulk of anaphase. Observations from low light level video images of the fluorescence distribution indicate that the [Ca] increase is uniform throughout the mitotic apparatus and does not show a discrete spatial localization as reported by Ratan et al. (22). It thus becomes apparent, even from studies on closely similar cells (PtK₁

1. *Abbreviations used in this paper:* AA-III, arsenazo III; AM, acetoxymethyl ester; [Ca], calcium concentration; MT, microtubule; S/H, sample/hold.

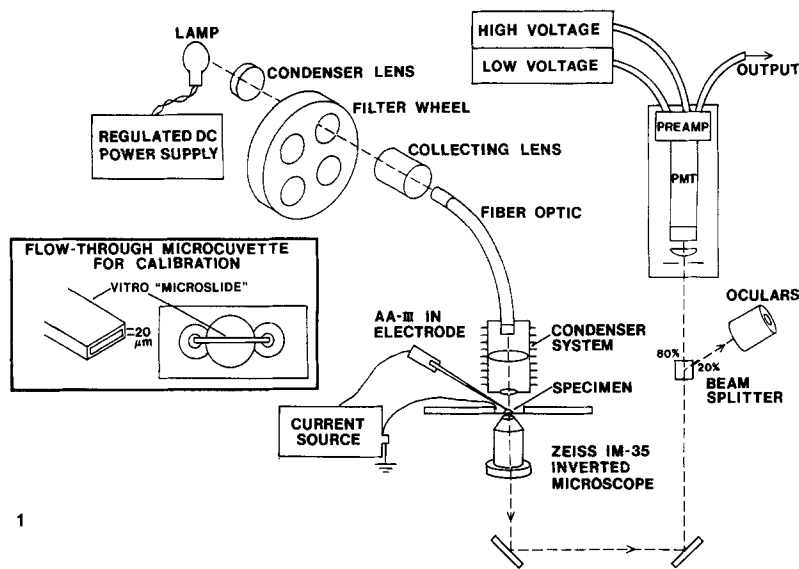

Figure 1. Diagram of the spinning wheel microspectrophotometer apparatus. A 50 W/12 V tungsten-halogen lamp operated in a high efficiency arc lamp housing ($f/0.7$) and powered by a highly regulated power supply provides intense, stable illumination. The collimated output beam is brought to focus at the position of the filter wheel by a condenser lens. Light that passes through the interference filters in the rotating wheel is refocused by a collecting lens onto one end of the 0.125-inch fiber optic bundle that provides a vibration-free link to the microscope. The distal end of the fiber optic bundle is positioned precisely at the back focus of the Zeiss IM-35 transmitted light illuminator, and subsequently light is condensed on the specimen and forms an image through the conventional optical path of the microscope. A beam splitter provides for simultaneous viewing (20%) and measuring (80%) of the image. A 1-mm aperture in the measuring image plane selects a region of the cell for measurement by the photomultiplier (PMT) photometer. (Inset) The flow-through microcuvette arrangement used for calibration of the microspectrophotometer.

A Microslide (Vitro Dynamics, Inc.) of 20- μm optical path length is located across a cut-out microscope slide and held in position by paraffin dams at each end. Standard solutions placed in the dam at one end are drawn through by filter paper wedges while leaving the Microslide unmoved. It is important that the microcuvette not be displaced since the minute variations in the optical path through the dye or variations in wall thickness along the length will produce major variations of the output in the dye-loading mode or measuring mode, respectively.

and PtK₂) using one dye (fura-2), that there are important differences in the reported timing and location of the [Ca] increase.

Studies of endosperm cells and sea urchin embryos provide information generally supporting the contention that [Ca] increases during anaphase. With the endosperm cells, however, quin2 AM was used as the Ca indicator (15). If the dye exhibits its inferior properties in these cells as it does in PtK cells then by comparison the results should be treated with caution. The investigation of sea urchin embryos (20) makes a more compelling story since in some, but not all examples, Ca transients are shown to occur periodically throughout the cell cycle. After a large spike at fertilization, subsequent elevations are observed in a small percentage of cells at pronuclear migration, streak stage, nuclear envelope breakdown, onset of anaphase, and cytokinesis. These elevations of Ca occur over several minutes and show a rough temporal correlation with the particular events of mitosis.

Taken together these results provide new ideas about the control of mitosis, but they are only the beginning. Much more work is needed, including investigation on different cell types with different indicators, to establish if there is a common pattern of Ca fluctuation that is temporally and spatially correlated with the events of mitosis. In this study we report the occurrence of Ca changes in mitotic *Tradescantia* stamen hair cells that have been loaded with the metalochromic absorbance dye arsenazo III (AA-III). We show that the [Ca] increases during anaphase, with the rise beginning slightly after the initial separation of the chromosomes.

Materials and Methods

Measuring Equipment

For the purpose of measuring very small changes in absorbance through the microscope, we constructed a "spinning wheel" type microspectrophotome-

ter (Figs. 1 and 2) along the principles established by others (5, 7, 23, 26). We have attempted to optimize our microspectrophotometer for sensitivity and long-term stability rather than rapid response based on the assumption that [Ca] changes in the MA probably occur in the time domain of seconds rather than milliseconds. The effective time constant of the system including the sampling interval, sampling frequency, and hardware time constant has been set to 1.5 s.

The illuminator consists of a 12 V/50 W tungsten halogen lamp (model HLX 64610; Osram GmbH, Berlin, Federal Republic of Germany) operated in a modified arc lamp housing and powered by a power supply (0.05% load/line regulation; model LCS-C-15; Lambda Electronics Corp., Melville, NY) operated at 11.5 V. The collimated output beam is focused by a 65-mm focal length auxiliary lens producing a $3.6\times$ image of the filament at the position of the interference filters. A 5-mm-diam aperture at the filter wheel (Fig. 1) restricts stray illumination and results in flat topped output light pulses that greatly facilitate signal processing. The filter wheel with four 1.0-inch ports for interference filters is located in the illumination path just beyond the aperture and is driven at 1,920 rpm by a toothed belt drive. The light passing the filter is collected and refocused onto the end of a 24-inch fiber optic cable (1/8 inch diam) that couples the illuminator to the microscope; the distal end of this fiber optic is located at the position of the usual filament of the Zeiss IM-35 transmitted light illuminator. Normal imaging optics are used on the microscope: a $40\times$ objective is used for dye loading and a $63\times$ oil objective (NA 1.4) is used for the measurements. A beam splitter (20% viewing/80% photometer) is used to allow simultaneous viewing and measurement. A Zeiss SF photometer head fitted with a 1.0-mm aperture is used to delimit the image area transmitted to the measuring system.

A Hamamatsu R1104 photomultiplier operated at approximately 450 V (HV regulation better than 0.05%) was used for light detection with the anode current scaled at 1 V/ μA by a current to voltage converter. This signal was processed by a signal processing block under control of a Rockwell AIM 65 microcomputer as described below and illustrated in Fig. 2.

Signal Processing

The signal processing block consists of the following: two stages of digitally programmable amplification, a four channel sample/hold (S/H), an eight channel differential multiplexer, a gain programmable differential amplifier, and an eight bit analog-to-digital converter all interfaced to the Rockwell AIM 65 computer. Additionally, the AIM 65 is interfaced to the strobe and filter encoding signals from the spinning wheel unit that provide basic system synchronization. The operation of this system occurs in two stages that

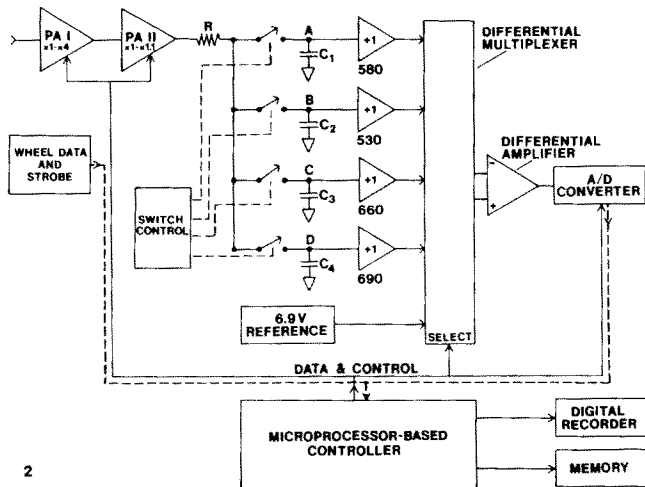

Figure 2. Signal processing block diagram. The time domain multiplexed signal from the photometer flows through the programmable amplifiers (PA I, PA II) and is demultiplexed by the switch control and S/H circuits. All signals follow the same signal path through all gain stages to reduce differential effects of drift with temperature variations and time. The wheel strobe and data signals provide timing and demultiplexing information to the computer that, in response, loads the correct amplifier digital gain codes and gates the signal to the appropriate S/H. At intervals the computer accesses paired channels through the differential multiplexer to the differential amplifier, and obtains a value from the analog-to-digital (A/D) converter which is stored in memory for program use and output (selected data) to the recorder.

differ slightly between the "dye loading" and "measuring" modes. The first stage, common to both modes, consists of balancing each channel to match the reference voltage level (6.950 V). The strobe from the filter wheel occurs 0.125 revolution before the filter intersects the illumination path and prompts the AIM 65 to begin timing a delay and also to determine which filter is approaching. This information determines the appropriate S/H channel to be used for the sampling period that occurs at the end of the delay. The computer also loads one of the programmable amplifiers (PA II, Fig. 2) with a binary code (initially midscale) appropriate for this filter. Each filter in the wheel has been initially balanced with gelatin neutral density material to produce an output pulse of uniform amplitude, thus compensating for the spectral qualities of the illuminator, lenses, fiber optic, and photomultiplier. The residual imbalance and cell to cell variations require a final stage of balancing. After gating 32 pulses to each S/H, the computer, via the differential multiplexer and instrumentation amplifier, sequentially compares each channel amplitude with the reference level and calculates an updated gain value based on the error. This process is repeated until all channels are very close to the reference level; the computer then saves these values and enters the second phase which depends on the mode selected.

To measure the amount of dye loaded into the cell the 580 nm channel output is compared with the reference level (V_{ref}). Since the output of the 580 nm channel is directly proportional to the detected intensity, and since the levels are initially equal, the difference $V_{ref} - V_{580}$ is equivalent to the change in absorbance at 580 nm. The log function is essentially linear for small changes. In the dye-loading mode this difference, at a gain of 4X, is read at 1-s intervals and also output to a recorder so that the progress of the iontophoretic loading can be followed and accurately regulated.

Once the dye has been loaded and other manipulations performed, the computer repeats the balancing procedure but enters the measuring mode when all channels have been balanced. In this mode, every cycle of sampling is followed by a comparison of the 580 nm channel amplitude with the reference level and the error is immediately used to adjust the gain value of the second programmable amplifier, the automatic gain control. The automatic gain control affects all channels equally and helps to compensate for variations in lamp intensity, dye concentration, and instrumental gain drifts. The use of feedback to control the isosbestic channel amplitude alleviates any errors that might arise from changes in the common mode voltage presented to the differential amplifier as a result of various instrumental and biological



Figure 3. Low magnification photomicrograph of immature *Tradescantia* stamen hair preparation as used for experiments. The second and fifth cells (arrows) are microinjected with AA-III to an indicated absorbance of 0.06 A. The eighth cell (X) is killed with the micropipette to block the loss of the AA-III to proximal cells. The small vacuolar volume of the tip cell can be seen to be largely confined to the proximal end and away from the region of measurement. Bar, 10 μ m.

factors that cannot be regulated (Fig. 1). The computer reads the 660–690 differential absorbance ($A_{660-690}$) at a gain of 20 \times every 32 cycles and outputs this value to the recorder.

Experimental Methods

Stamen hairs isolated from immature flower buds of *Tradescantia virginiana* were immobilized in a thin layer of 1% agarose (type VII; Sigma Chemical Co., St. Louis, MO) containing 0.05% Triton X-100. The preparation was then flooded with buffer containing 5 mM HEPES, 20 mM KCl, and 1 mM CaCl_2 at pH 7.0. Filaments with long cylindrical tip cells in late prophase were selected for measurement; this morphology is characteristic of young stamen hairs and these cells have a few, small vacuoles located primarily at their ends. Arsenazo III (A-8891; Sigma Chemical Co.) was iontophoretically microinjected into the second and fifth cells of the stamen hair to a $A_{580} = 0.06$ ($\sim 800 \mu\text{M}$) measured in the injected cells. The micropipette tip contained 10 mM AA-III in distilled water and the shaft contained 10 mM KCl; 1 nA of current passage for 30–45 s was required to load cells with the dye to the desired concentration. Because the hair cells are coupled (30) small molecules (1 kd) like AA-III move quickly into neighboring cells through plasmodesmata. We were thus able to load the dividing tip cell of the hair without impaling it. The eighth cell of the hair was killed with the micropipette (Fig. 3), and as a result of the rapid plugging of the plasmodesmata at the boundary between the seventh and eighth cells, the dye became confined to the remaining seven live cells. We estimate that the final concentration of AA-III is $\sim 300 \mu\text{M}$ in each cell of the hair but due to several factors such as differential dye transport, variation in cytoplasmic volume, etc., the actual level in the dividing cell could vary upward or downward from the estimate. A coverslip placed over the preparation and sealed with melted Vaseline prevents evaporation of the buffer and associated changes in the background absorbance.

A 63 \times (1.4 NA) oil immersion objective used to monitor the dye-dependent absorbance changes allowed the capture of essentially all of the forward scattered light and minimized the effects of differential scattering that might accompany changes in chromatin condensation or chromosome and organelle movements. The cell was continually observed while the photometer recorded from 80% of the transmitted light. The stages in the progress of cell division were visible at all times and the pertinent time points were noted on the chart.

Controls were selected from identical material and the eighth cell was also killed but no AA-III was loaded; these preparations were otherwise handled and recorded in exactly the same manner as the dye-loaded cells.

Results

Ca Detection In Vitro

Because the results depend upon the performance of our microspectrophotometer system an attempt has been made to test its sensitivity. For this we have used very small microcuvette chambers (Vitro Microslides; Vitro Dynamics, Inc., Rockaway, NJ) with a fixed path length of 20 μ m, which is smaller than the 25–30- μ m path length of a stamen hair cell.

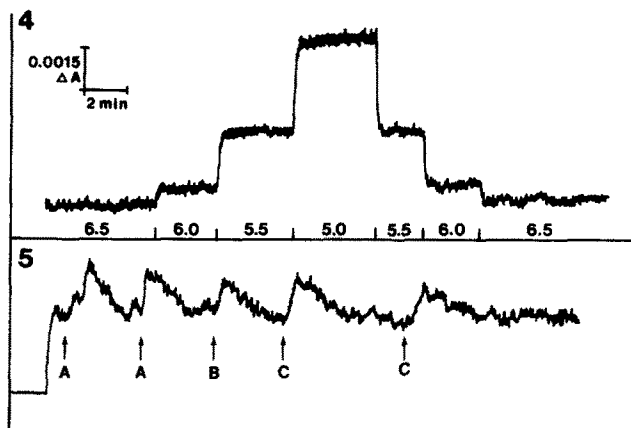

Figures 4 and 5. (Fig. 4) Recording of a stepped calcium concentration calibration using a 20 μm path microcuvette. All solutions contained 400 μM AA-III, 20 mM Hepes, 1 mM free Mg^{2+} , and the specified values for pCa. (Fig. 5) Recording of an in vivo calibration in which Ca^{2+} was iontophoretically injected into the tip cell of a *Tradescantia* stamen hair that had been loaded 75 min earlier with AA-III. Ca^{2+} was introduced iontophoretically from a pipette containing 100 mM CaCl_2 to a level inside the cell just sufficient to stop cytoplasmic streaming ($\sim 1 \mu\text{M}$). Because the cell rapidly plugs Ca-containing pipettes the time of injection had to be increased in order to reach the appropriate level. (A) 5 s, 2 nA; (B) 6 s, 2 nA; (C) 10 s, 2 nA. The scale factors are the same as in Fig. 4.

Stock solutions of 400 μM AA-III in a Ca-EGTA buffer, which contains a predetermined free [Ca], are perfused through the microcuvettes and the absorbance change due to the free [Ca] recorded. The results (Fig. 4) show a clear and repeatable absorbance change between 0.3–1.0 μM Ca and higher. From the magnitude of the absorbance change between 0.3 and 1 μM Ca we estimate that half the difference could be reliably resolved. Thus we feel that the instrument is capable of detecting [Ca] changes of $\sim 0.35 \mu\text{M}$.

Ca Detection In Vivo

To test the performance of the spectrophotometer on living cells we have used *Tradescantia* stamen hairs that have been loaded with AA-III according to our standard method. Thereafter we have iontophoretically injected Ca into these cells and recorded the resulting absorbance changes. Because cytoplasmic streaming is inhibited by levels of Ca approaching 1 μM (11) we have used this phenomenon as an independent measure of the [Ca]. Thus we find that the amount of Ca sufficient to just stop cytoplasmic streaming gives a substantial absorbance change (Fig. 5). A further feature of the trace shown in Fig. 5 is the fact that the cell had been loaded with dye for over an hour before the Ca injection was made, demonstrating that the dye remains in the cytoplasm as a viable indicator for periods of time that are long enough to extend through mitosis. We have also tested dye-loaded cells after the completion of mitosis and have found that they too show a similar absorbance change when injected with a brief pulse of Ca (data not shown). Brief iontophoretic injection of potassium has no effect on the cytoplasmic streaming or on the absorbance shift.

[Ca] Changes during Mitosis

Cells entering prometaphase are loaded with AA-III as previously described and allowed to progress through mitosis while measurements are being made. The results (Fig. 6 a) show that during metaphase the [Ca] remains constant. However, immediately after the separation of sister chromosomes, marking the onset of anaphase, the [Ca] begins to ramp upwards. The increase occurs during a 10–15-min period and attains a peak at the point when the chromosomes reach the poles. Thereafter the [Ca] declines; at about the time the Ca returns to the basal level or a few minutes earlier a phase-dense line demarking the onset of the cell plate appears. The same trace has been observed regardless whether the measuring spot is over the center of the mitotic apparatus

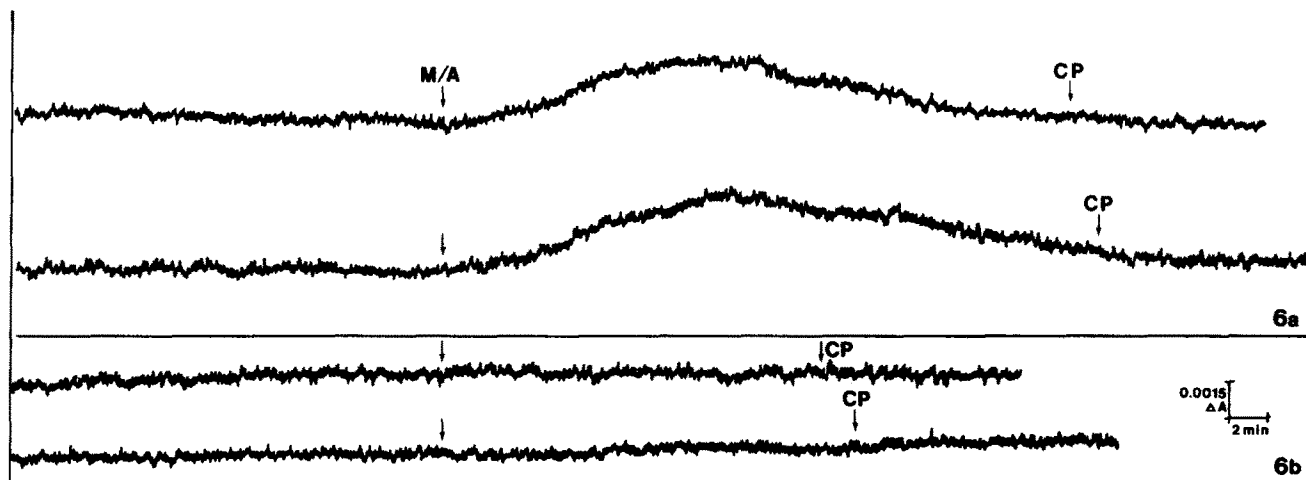

Figure 6. Recordings made of differential absorbance at the 660–690 nm wavelength pair ($A_{660-690}$) with mitotic cells. (a) Recordings from two cells injected at the time of nuclear envelope breakdown with AA-III using our standard injection protocol. The times of the metaphase/anaphase transition (M/A) and cell plate formation (CP) are marked on the recordings. The time and ΔA scale is the same as given for b. (b) $A_{660/690}$ recordings of two mitotic cells that were not loaded with dye but had the eighth cell killed. The timing of M/A and CP are marked. There is very little change in the differential absorbance, $A_{660-690}$ in cells not loaded with AA-III. The time from M/A to the formation of the cell plate is slower and more variable in most dye injected cells than in control cells.

Table I. Summary of Differential Absorbance Measurements*

Stage of mitosis	Control cells		AA-III-loaded cells	
	Mean	Standard deviation	Mean	Standard deviation
Midmetaphase [‡]	0.00	0.00	0.00	0.00
Metaphase–anaphase transition	0.04	0.66	–0.01	0.08
Late anaphase [§]	0.10	0.05	0.38 [†]	0.32
Cell plate initiation	0.13	0.09	0.12	0.18

An analysis of variance repeated measures design reveals that the differential absorbance at the late anaphase point in the AA-III-loaded cells is significantly increased over all other points.

* Read in volts from the chart recorder.

[‡] 10 min before the metaphase–anaphase transition.

[§] Chromosomes at the poles.

^{||} $n = 10$.

[†] Significantly different from all other points, $P < 0.05$, Wilk's lambda test.

or over a spindle pole. Of the 10 dye-loaded cells analyzed at 660–690 nm we have not detected an absorbance increase that precedes the onset of anaphase. There is, however, variation in the magnitude of change that occurs during anaphase from some examples in which the increase in $A_{660-690}$ is

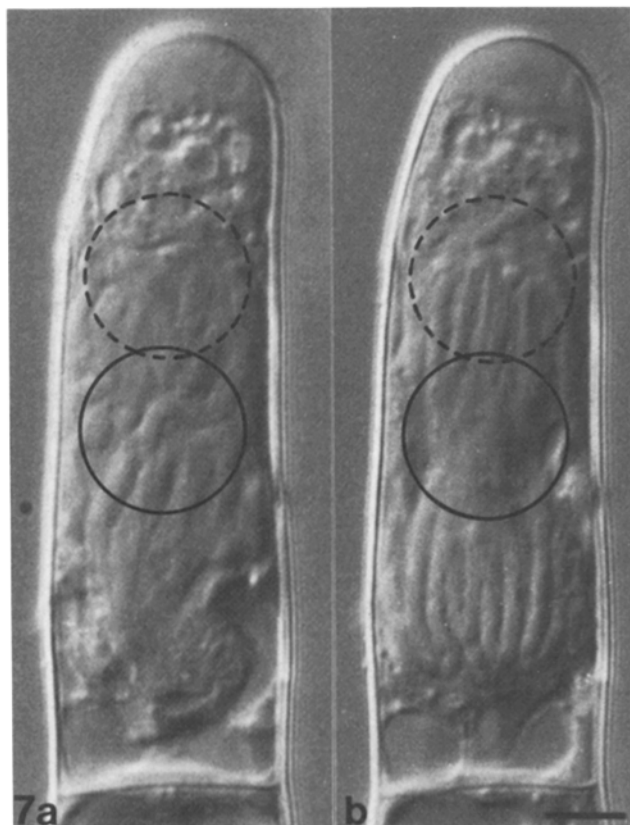

Figure 7. Time lapse micrographs from a cell in late metaphase (a) and late anaphase (b) are marked with circles to show the two separate regions delimited by the photometer aperture in which absorbance measurements were made. In some cells the aperture was centered over the metaphase plate (solid circle). Under these conditions the chromosomes moved out of the measuring area during anaphase. In other cells the aperture was centered over the spindle pole (broken circle). Here chromosomes moved into the measurement area during anaphase. Bar, 10 μ m.

quite slight to others in which the change in differential absorbance is quite substantial (Fig. 6 a).

Table I provides a summary analysis of 10 control and 10 AA-III-loaded cells as they proceed through mitosis. A comparison of the changes in differential absorbance has been made at four points defined as follows: (a) midmetaphase (10 min before the metaphase/anaphase transition); (b) the metaphase/anaphase transition; (c) late anaphase (chromosomes at the poles); and (d) cell plate initiation. A statistical analysis indicates that the differential absorbance at late anaphase in AA-III-loaded cells is significantly elevated over all other values.

An issue that has concerned us has been the possible occurrence of an absorbance-scattering artifact due to movement of chromosomes and other cellular inclusions during anaphase. The data from uninjected cells (Table I; Fig. 6 b) reveal a flat trace and indicate that there is no systematic change in absorbance during mitosis. However, it may be possible that in dye-loaded cells, AA-III binds to proteins or chromatin in such a way that the movement of chromosomes or other cellular inclusions during anaphase would cause a change in differential absorbance that would not be compensated for in the uninjected controls. In an effort to test for this we have measured absorbance changes in both the spindle center and spindle pole and find no difference as the cells progress through anaphase (Fig. 7, a and b). Thus, the migration of chromosomes either away from or into the measuring spot does not change the resulting pattern of differential absorbance. We conclude that a “binding-movement” artifact does not account for the observed results.

Another issue of concern has been the possible interference of intracellular pH, since it has been reported that AA-III responds to changes in the $[H^+]$ (26). In an independent study (18) the possible occurrence of pH fluctuations during mitosis has been examined in stamen hair cells of *Tradescantia* injected with the fluorescent dye bis carboxyethyl carboxyfluorescein. The results failed to reveal any pH-dependent changes in the fluorescence ratio measurements during metaphase and anaphase. Based on the limitations of the detection system, if pH changes occur they would probably be <0.15 pH units, or confined to local domains of the spindle apparatus, or <2 min in duration. To further address the problem we have directly tested the effect of buffered solutions of different pH on the differential absorbance of AA-III at the measuring wavelengths (660–690 nm). Between pH 6.8 and 6.5 ($\Delta 0.3$ u) we detect a small change in absorbance which is $<10\%$ of the maximum absorbance differential measured during anaphase. Taken together, we conclude that pH fluctuations do not contribute significantly to the change in AA-III absorbance observed during mitosis.

The presence of AA-III to a certain extent modifies the process of mitosis. At the levels we normally use, and even higher, the dye does not block mitosis but it does slow the progression through mitosis. For example comparison of Fig. 6 a reveals that the AA-III-loaded cells require 30 and 32 min to progress from the onset of anaphase to cell plate formation as compared with 18 and 25 min for the controls (Fig. 6 b). From the population of 10 dye-loaded cells and 10 controls the mean metaphase transit time is 41.2 ± 15.0 min in AA-III vs. 31.0 ± 4.8 min for the controls and the time from anaphase onset to cell plate formation is 26.9 ± 3.2 min in AA-III vs. 21.0 ± 2.8 min for the controls. We hasten to

add, though, that direct inspection of the dye-loaded cells has not revealed any consistent structural differences or abnormalities from the controls.

Discussion

The results presented herein indicate a change in free [Ca] during anaphase in the mitotic apparatus of *Tradescantia* stamen hair cells. The increase is first detected after the chromosomes have undergone their initial separation and continues while the chromosomes move to the poles. The [Ca] declines thereafter with the cell plate appearing at about the time that basal levels are reattained.

Because we are able to observe the cells continuously while measurements are being made, we have been able to provide considerable temporal precision concerning the occurrence of the metaphase/anaphase transition relative to the [Ca] increase. Our observations place the transition before a detectable increase in [Ca]. We cannot rule out the occurrence of a small $<0.3 \mu\text{M}$ pulse of Ca, or even larger ones that might occur in small, local domains, and become averaged out due to the large area measuring spot in our detection system. However, based on the 1.5-s time constant and sensitivity of our instrument we believe that we would have detected a panspindle increase in [Ca] to $0.8 \mu\text{M}$, similar to that reported in PtK₁ cells (19), if it had occurred. We therefore feel these data question the general concept of Ca acting as a trigger for anaphase onset (9, 13, 19, 22).

The [Ca] increase in *Tradescantia* correlates remarkably well with the time when the chromosomes are moving to the poles and thus with the time when the kinetochore spindle MTs are breaking down. Previous studies have shown that over 90% of anaphase movement in *Tradescantia* is anaphase A or movement towards the poles (10). The data are consistent with the idea that the increase in [Ca] facilitates the depolymerization of the kinetochore spindle MTs and thus regulates the rate of chromosome motion. A further close temporal correlation between [Ca] and MTs is shown during telophase. Here the [Ca] declines before cell plate formation and one can speculate that the reduction is necessary to permit the formation of the phragmoplast, a well known MT organelle. The results thus reveal a striking correspondence between Ca elevation and MT breakdown, followed by Ca decline and MT formation. One has reason to suspect that Ca, probably together with calmodulin, is the intracellular regulator of MT formation.

The long duration (20–30 min) of the Ca transient in *Tradescantia* contrasts markedly with the brief spike (20 s) reported by Poenie et al. (19) in PtK₁ cells. However, it must be noted that in PtK cells there are reported differences. For example, Ratan et al. (22) allow that the elevated level of Ca lasts throughout anaphase and even Tsien and Poenie (27), in a review article, show a PtK₁ cell in which the Ca elevation is 2 min or about the length of anaphase. One hopes that future work will settle these observed differences and arrive at a consistent pattern of Ca transients if one exists.

The exact magnitude of the Ca rise in *Tradescantia*, unfortunately, cannot be exactly determined owing to uncertainty about the dye concentration and Ca/dye stoichiometry (1, 17, 25). Also possible dye/protein binding (3) might further confuse the relationship in the cell of the change in differential absorbance to the change in [Ca]. We are limited therefore

to an approximation of the free [Ca]. However, based on the in vitro calibration and the in vivo tests on Ca-dependent-streaming inhibition, we estimate that the absorbance changes we observe during late anaphase correspond to a [Ca] of 1–3 μM .

An area of major concern in interpretation of the results rests with the possible artifact introduced by the reporting dye molecule and the method of detection used. The fluorescent indicators introduced by Tsien and co-workers (8, 27, 28) have been impressive in permitting measurements that have been extremely difficult heretofore. But these fluorescent probes are not without problems. The AM form of these dyes may load into intracellular membrane compartments (2, 24, 31) before being cleaved by esterase. Indeed Poenie et al. (19) allow that special, suboptimal conditions, such as lower culture temperature, are required to load fura-2 AM into PtK cells without having the dye become sequestered by exocytotic vesicles. But even the free anion of fura-2 can be a problem since in *Tradescantia* it quickly transports into the vacuole and becomes useless as a cytoplasmic indicator (unpublished observations).

It has been for the above reasons that we turned to AA-III as a Ca indicator for studies on *Tradescantia*. AA-III has been used extensively for many years, especially in studies on Ca transients in nerve and muscle cells; its characteristics are well known (4, 23, 26). Suffice it to say that in *Tradescantia* AA-III has the favorable property of remaining in the cytoplasm and serving as a viable Ca indicator for relatively long periods of time. However, a specific difficulty we observed is the tendency for the dye to slow the process of mitosis. We believe this is due to the relatively large concentration of AA-III ($\sim 300 \mu\text{M}$), which apparently competes for Ca and blunts the increase caused by the cell. We hasten to add though that the dye does not kill the cells since even heavily loaded cells complete mitosis.

We are at an exciting new point in studies on Ca regulation of mitosis. The focus has been largely on metaphase-anaphase and has so far included only a few cell types and measuring methods. The development of new dyes or new sensitive methods to use older dyes will greatly aid us in our quest to establish the pattern of Ca changes during mitosis. We must also turn our attention to other phases of mitosis such as the prophase-prometaphase transition where important biochemical and structural changes also occur. Measuring the underlying Ca changes may help us decipher the mechanism of mitotic regulation.

We thank Dr. Steven Smith, Yale University, for advice and encouragement in the development of the microspectrophotometer. Ms. Trina Hosmer, University of Massachusetts Computing Center, has provided valuable assistance in performing the statistical analysis and Ms. Susan Lancelle has helped greatly in the preparation of this report.

Support for this study has been provided by National Science Foundation, grants DCB-8502723 and PCM-8402414.

Received for publication 12 March 1987, and in revised form 29 June 1987.

References

1. Ahmed, Z., L. Kragie, and J. A. Connor. 1980. Stoichiometry and apparent dissociation constant of the calcium-arsenazo III reaction under physiological conditions. *Biophys. J.* 32:907–920.
2. Almers, W., and E. Neher. 1985. The Ca signal from fura-2 loaded mast cells depends strongly on the method of dye-loading. *FEBS (Fed. Eur. Biochem. Soc.) Lett.* 192:13–17.
3. Beeler, T. J., A. Schibeci, and A. Martonosi. 1980. The binding of ar-

- senazo III to cell components. *Biochim. Biophys. Acta.* 629:317-327.
4. Blinks, J. R., W. G. Wier, P. Hess, and F. G. Prendergast. 1982. Measurement of calcium concentrations in living cells. *Prog. Biophys. Mol. Biol.* 40:1-14.
 5. Chance, B., V. Legallais, J. Sorge, and N. Graham. 1975. A versatile time-sharing multichannel spectrophotometer, reflectometer, and fluorometer. *Anal. Biochem.* 66:498-514.
 6. Deleted in proof.
 7. Gorman, A. L. F., and M. V. Thomas. 1978. Changes in the intracellular concentration of free calcium ions in a pace-maker neurone, measured with the metallochromic indicator dye aresenzo III. *J. Physiol.* 275:357-376.
 8. Gryniewicz, G., M. Poenie, and R. Y. Tsien. 1985. A new generation of Ca^{2+} indicators with greatly improved fluorescence properties. *J. Biol. Chem.* 260:3440-3450.
 9. Hepler, P. K. 1985. Calcium restriction prolongs metaphase in dividing *Tradescantia* stamen hair cells. *J. Cell Biol.* 100:1363-1368.
 10. Hepler, P. K., and B. A. Palevitz. 1985. Metabolic inhibitors block anaphase A in vivo. *J. Cell Biol.* 102:1995-2002.
 11. Hepler, P. K., and R. O. Wayne. 1985. Calcium and plant development. *Annu. Rev. Plant Physiol.* 36:397-439.
 12. Hepler, P. K., and S. M. Wolniak. 1983. Membranous compartments and ionic transients in the mitotic apparatus. In *Modern Cell Biology*. Vol. 2. J. R. McIntosh, editor. Alan R. Liss, Inc., New York. 93-112.
 13. Izant, J. G. 1983. The role of calcium ions during mitosis. Calcium participates in the anaphase trigger. *Chromosoma (Berl.)* 88:1-10.
 14. Keith, C. H., F. R. Maxfield, and M. L. Shelanski. 1985. Intracellular free calcium levels are reduced in mitotic Ptk2 epithelial cells. *Proc. Natl. Acad. Sci. USA.* 82:800-804.
 15. Keith, C. H., R. Ratan, F. R. Maxfield, A. Bajer, and M. Shelanski. 1985. Local cytoplasmic gradients in living mitotic cells. *Nature (Lond.)* 316:848-850.
 16. Deleted in proof.
 17. Palade, P., and J. Vergara. 1983. Stoichiometries of arsenazo III-Ca complexes. *Biophys. J.* 43:355-369.
 18. Pheasant, D. J., and P. K. Hepler. 1987. Intracellular pH change is not detectable during the metaphase/anaphase transition in *Tradescantia* stamen hair cells. *Eur. J. Cell Biol.* 43:10-13.
 19. Poenie, M., J. Alderton, R. Steinhardt, and R. Tsien. 1986. Calcium rises abruptly and briefly throughout the cell at the onset of anaphase. *Science (Wash. DC)* 233:886-889.
 20. Poenie, M., J. Alderton, R. Y. Tsien, and R. A. Steinhardt. 1985. Changes of free calcium levels with stages of the cell division cycle. *Nature (Lond.)* 315:147-149.
 21. Ratan, R. R., and M. L. Shelanski. 1986. Calcium and the regulation of mitotic events. *Trends Biochem. Sci.* 11:456-459.
 22. Ratan, R. R., M. L. Shelanski, and F. R. Maxfield. 1986. Transition from metaphase to anaphase is accompanied by local changes in cytoplasmic free calcium in Ptk2 kidney epithelial cells. *Proc. Natl. Acad. Sci. USA.* 83:5136-5140.
 23. Scarpa, A. 1979. Measurement of calcium ion concentrations with metallochromic indicators. In *Detection and Measurement of Free Ca^{2+} in Cells*. C. C. Ashley and A. K. Campbell, editors. Elsevier/North Holland, Amsterdam. 85-115.
 24. Siskin, J. E., D. L. Taylor, and A. Wallace. 1986. Nuclear fluorescence in cells exposed to fura-2 AM or scrape-loaded with fura-2. *J. Cell Biol.* 103:(5, pt. 2):452a. (Abstr.)
 25. Thomas, M. V. 1979. Stoichiometry of the calcium-arsenazo III complex. In *Detection and Measurement of Free Ca^{2+} in Cells*. C. C. Ashley and A. K. Campbell, editors. Elsevier/North Holland, Amsterdam. 309-318.
 26. Thomas, M. V. 1982. *Techniques in Calcium Research*. Academic Press, Inc., London. 214 pp.
 27. Tsien, R. Y., and M. Poenie. 1986. Fluorescence ratio imaging: a new window into intracellular ionic signalling. *Trends Biochem. Sci.* 11:450-455.
 28. Tsien, R. Y., T. Pozzan, and T. J. Rink. 1982. Calcium homeostasis in intact lymphocytes: cytoplasmic free calcium monitored with a new intracellularly trapped fluorescent indicator. *J. Cell Biol.* 94:325-334.
 29. Tsien, R. Y., T. J. Rink, and M. Poenie. 1985. Measurement of cytosolic free Ca^{2+} in individual small cells using fluorescence microscopy with dual excitation wavelengths. *Cell Calcium.* 6:145-157.
 30. Tucker, E. B. 1982. Translocation in the staminal hairs of *Setcreasea purpurea*. I. A study of cell ultrastructure and cell-to-cell passage of molecular probes. *Protoplasma.* 113:193-201.
 31. Williams, D. A., K. E. Fogarty, R. Y. Tsien, and F. S. Fay. 1985. Calcium gradients in single smooth muscle cells revealed by the digital imaging microscope using fura-2. *Nature (Lond.)* 318:558-561.
 32. Wolniak, S. M., and K. M. Bart. 1985. The buffering of calcium with quin2 reversibly forestalls anaphase onset in stamen hair cells of *Tradescantia*. *Eur. J. Cell Biol.* 39:33-40.
 33. Wolniak, S. M., and K. M. Bart. 1985. Nifedipine reversibly arrests mitosis in stamen hair cells of *Tradescantia*. *Eur. J. Cell Biol.* 39:273-277.