

Received: 2015.07.25  
Accepted: 2015.10.21  
Published: 2016.03.30

# Post-Exposure Exercise Fails to Ameliorate Memory Impairment Induced by Propofol and Ketamine in Developing Rats

Authors' Contribution:  
Study Design A  
Data Collection B  
Statistical Analysis C  
Data Interpretation D  
Manuscript Preparation E  
Literature Search F  
Funds Collection G

BCE 1 **Li-Hong Jin**  
CD 2 **Yan-Yan Song**  
DF 1 **Yang Shen**  
CG 1 **Wei Ji**  
AEG 1 **Ma-Zhong Zhang**

1 Department of Anesthesiology, Shanghai Children's Medical Center, Shanghai Jiao Tong University School of Medicine, Shanghai, P.R. China  
2 Department of Pharmacology and Biostatistics, Institute of Medical Sciences, Shanghai Jiao Tong University School of Medicine, Shanghai, P.R. China

**Corresponding Author:** Ma-Zhong Zhang, e-mail: 1738089011@qq.com  
**Source of support:** Departmental sources

**Background:** This aim of this study was to determine the effects of ketamine-propofol combination on learning and memory, as well as exercise, on anesthetic neurotoxicity.





**Material/Methods:** A ketamine-propofol combination was administered once (group SKP, Single Ketamine Propofol) on P7 (post-natal day 7) or in 3 treatments on P6, P8, and P10 (group MKP, Multiple Ketamine Propofol). Rat pups in group C (Control) received equivalent volumes of normal saline in 3 injections on P6, P8, and P10. Rats designated MKPR (Multiple Ketamine Propofol and running) and CR (Control and running) began running exercise on P21 on wheels. Learning and memory was assessed by Morris water maze and fear conditioning tests. Hippocampal neurogenesis of rats was detected by BrdU immunofluorescence.

**Results:** MKP rats had longer latency to platform than group C during training in the Morris water maze; SKP rats stayed in the target quadrant longer than MKP rats during testing ( $P < 0.05$ ). Rats in running groups had shorter latency than non-running rats, but running had no interaction with anesthesia exposure.

**Conclusions:** Repeat ketamine-propofol combination doses increase risk of memory impairment in developing rats. Running has no impact on anesthetic neurotoxicity.

**MeSH Keywords:** **Avoidance Learning • Ketamine • Memory Disorders • Propofol**

**Full-text PDF:** <http://www.medscimonit.com/abstract/index/idArt/895443>

 3625  2  5  28



## Background

A growing body of evidence suggests general anesthetics produce unwanted effects during the brain growth spurt (BGS), which proceeds from 1 to 2 week for rodent animals and extends from the third trimester of pregnancy to the first few years of postnatal life in human beings [1]. The key phases of brain development occur during this period and include numerous biochemical changes such as axonal and dendritic maturation and the establishment of neural connections. Preclinical studies have shown that changes in brain development threaten its structural and functional integrity and may lead to permanent impairment [1]. Animal studies suggest anesthesia is neurotoxic to the developing brain after neonatal exposure in rodents and primates. Published studies have typically addressed only 1 of the most commonly used anesthetic drugs, including ketamine, propofol, fentanyl, and volatile anesthetics [2]. However, clinical applications often require 2 or more drugs to obtain the desired effect, such as the report by Jevtovic-Todorovic et al., who used a cocktail of midazolam, nitrous oxide, and isoflurane [3]. These and subsequent studies of combined inhaled and intravenous anesthetics have suggested these combinations are more detrimental and cause persistent learning deficits. In this study, our focus was on a combination of intravenous anesthetics commonly used in pediatric anesthesia [4]: propofol, a  $\gamma$ -aminobutyric acid type A (GABA<sub>A</sub>) agonist, and ketamine, a potent N-methyl-D-aspartate (NMDA) antagonist. Prior to this study, Fredriksson et al. found that subcutaneous single treatment with a combination of propofol 10 mg/kg and ketamine 25 mg/kg in the prenatal period potentiated brain cell death and resulted in functional deficits in adult mice [5]. Given the possible differences between species, we tested the hypothesis that multiple rather than single exposure to a combination of propofol and ketamine at the same doses will cause functional deficits in adult Sprague-Dawley rats.

Millions of very young children receive single or multiple anesthesia exposures each year for circumcision, herniorrhaphy, or other surgeries. Recent epidemiologic studies have suggested an association between anesthesia/surgery and neurocognitive impairment [6]. Sanders et al. suggested a causal relationship between anesthesia and neonatal brain injury [7]. Therefore, we must identify ways to prevent or treat the neurocognitive consequences of anesthesia-induced developmental neurotoxicity, although the specific mechanisms of anesthetic-induced neurotoxicity remain unclear. In spite of this, researchers have begun to explore methods of prevention and treatment. Proposed neuroprotective strategies include erythropoietin, brain preconditioning with anesthetics, vitamins, dexmedetomidine,  $\alpha_2$ -adrenergic agonists, melatonin,  $\beta$ -estradiol, clonidine, xenon, lithium, hypothermia, L-carnitine, and erythropoietin, and environmental enrichment [8]. These proposed strategies have been tested in animal models but further studies are needed

to confirm these observations and facilitate clinical translation. Shih et al. demonstrated that delayed environmental enrichment reversed sevoflurane-induced memory impairment in rats [9]. Environmental enrichment and physical exercise, such as running, both have positive effects on neurogenesis [10,11]. Neurogenesis in the dentate gyrus is closely related to hippocampus-dependent function [12]. Here, we tested the hypothesis that running exercise, like an enriched environment, can improve learning and memory impairments caused by multiple exposures to anesthesia. We used a combination of anesthetics and examined the effects on neurogenesis.

The purpose of this study was to establish whether rats exposed to propofol and ketamine during the neonatal period experience consequences in spontaneous behavior, learning, and memory as adults. We also explored whether running could reduce or reverse neurotoxicity induced by anesthetic exposure. Finally, we observed changes in hippocampal neurogenesis to test this possible mechanism of anesthetic-induced neurotoxicity.

## Material and Methods

### Animals and treatments

Pregnant Sprague-Dawley rats were purchased; 80 offspring were used in these experiments with the approval of the local Animal Care and Use Committee. Pups were divided into 2 arms (arm A and B; Female/male=1:1). Pups in arm A (n=50) were raised for behavioral tests on postnatal day (P) 41. Pups in arm (n=30) B were sacrificed at P41 to evaluate the effects of anesthesia on neurogenesis. The experimental design and groups are shown in Figure 1. Pups in arms A and B were divided into 5 treatment groups. During postnatal weeks 1–2, a combination of subcutaneous (SC) ketamine 25 mg/kg (10 mg/mL) plus intraperitoneal (IP) propofol 10 mg/kg (10 mg/mL) were administered on P7 (Single Ketamine Propofol: SKP) or 3 administrations on P6, P8, and P10 (Multiple Ketamine Propofol: MKP). Pups in group C (Control) received equivalent volumes of normal saline in 3 injections on P6, P8, and P10. Ketamine was administered 5–10 min prior to the administration of propofol. Animals were observed for 90 min until they were awake and active, at which time they were returned to their mother. Pups remained with their mother until weaning on P21. All rats were kept in plastic cages at 22±0.5°C and 40% to 70% humidity with a 12 h light/dark cycle and *ad libitum* access to food and water.

### Running wheel exercise

Rats designated MKPR and CR began running exercise on P21 on wheels (diameter=32 cm) connected to an automatic

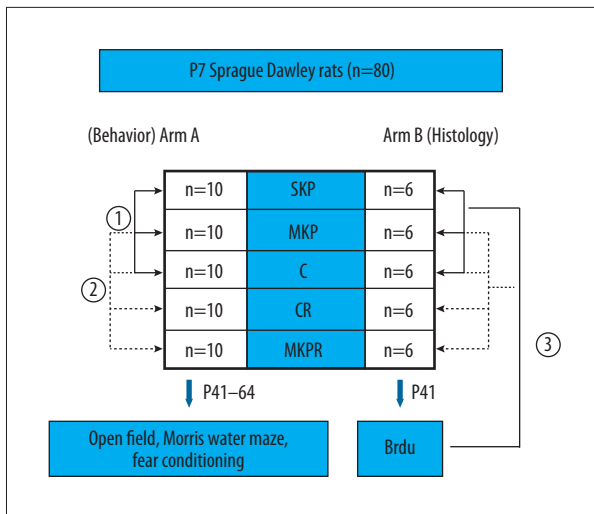

**Figure 1.** Experimental design. Three hypotheses were tested. (1) Multiple versus single exposure to propofol + ketamine will increase functional deficits in adult rats. (2) Running exercise can improve intravenous anesthesia-related learning and memory impairment. (3) Anesthesia-induced memory impairment will be improved by running exercise and alter hippocampal neurogenesis. P – postnatal day. SKP – single ketamine + propofol administration; MKP – multiple ketamine + propofol administrations; C – saline + saline, 3 times; MKPR – MKP plus running exercise; CR – C plus running exercise.

counter. Rats were allowed to run voluntarily, but sometimes were tapped lightly on the back if they refused to run. Two 15-min exercise sessions separated by a 15-min rest were administered daily for 10 days. Rats in non-running groups were put placed in the same equipment without running wheels.

## Behavioral tasks

### Open field

On P41, rats were placed in the center of an open field [13], which was a 50×50×60 cm rectangle with a black floor, grey walls, and an open roof. The zone 8 cm from the sidewall was defined as the central zone. A video camera installed on the ceiling recorded the total distance traveled, resting time in the central zone, and the average velocity over 10 min. The arena was cleaned after each test to remove odors.

### Morris water maze

On P45, rats underwent testing of spatial reference memory acquisition and retention in the Morris water maze [14]. The apparatus was a large circular pool, 150 cm across and 60 cm deep. The pool was divided into quadrants (east, west, north, south), and filled with 28 cm of warm water (maintained at

25±1°C). The A platform (diameter 15 cm; height 26 cm) was placed in the center of the north quadrant (the target) and submerged approximately 2.0 cm below the surface of the water. The pool was surrounded by a black curtain, with 3 white markers in different shapes and sizes, to prevent confounding visual cues.

### Hidden platform test

Rats were trained to locate a hidden platform. Four training sessions, spaced 30 min apart, were administered every day for 4 consecutive days. In each session, the rat was released from 1 of 4 quadrants facing the wall of the tank, and was allowed to swim a maximum of 90 s to find the hidden platform. If it did not find the platform in the allotted time, the rat was guided to the platform. In either case, the rat was allowed 30 s to rest on the platform and observe spatial cues. Each rat was released from different quadrants during the 4 sessions. Latency (time to reach the platform), and total distance were recorded with a video tracking system (Noldus, Ethovision XT).

### Probe trial

On P50, a probe trial was administered to assess memory retention with the platform removed from the tank. Rats were put into the pool from the quadrant opposite the target (South quadrant) and were allowed to swim for 90 s. Time spent in the previous target quadrant and the number of times the rats crossed the previous platform location were recorded.

### Fear conditioning

On P60, rats received fear conditioning for 340 s to assess the fear memory performance [15]. Individual rats were given 160 s to become familiar with the condition chamber, and then given a paired conditional (white noise, 80 db, 20 s, 2500 Hz) and unconditional (electrical foot shock, 1 mA, 2 s) stimulus. The stimuli were repeated 3 times with an inter-trial interval of 1 min. The unconditioned stimulus was delivered during the last 2 seconds of the conditioned stimulus. On P61, a contextual test was performed in the condition chamber for 5 min in the absence of white noise. A cue test was performed by presenting a cue (white noise, 80 db, 2500 Hz) for 3 min in an alternate context with distinct visual and tactile cues. The freezing (a period of watchful immobility) and freezing response rate (percentage of total test time) were scored automatically and used as a measure of fear memory.

### BrdU and histology

5'-Bromo-2-deoxyUridine (BrdU; Sigma) was dissolved in normal saline (10 mg/mL). Thirty rats in arm B received two IP injections of BrdU (50 mg/kg) on P39 and P40. On P41, the rats

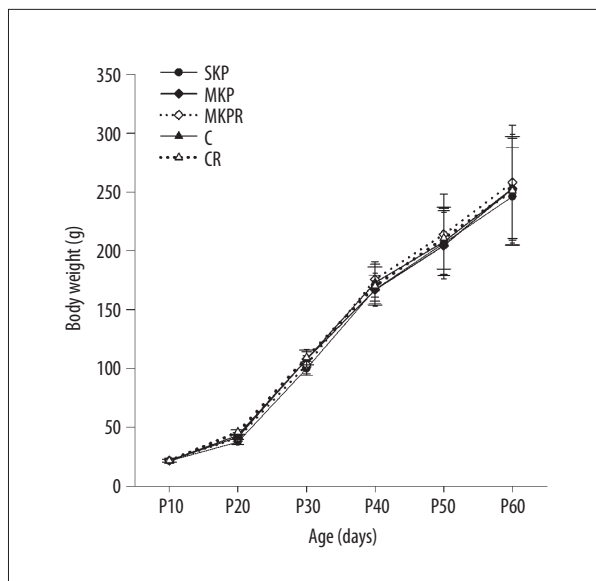

**Figure 2.** Body weight from P10 to P60. Anesthesia and wheel running did not influence body weight. SKP – single ketamine + propofol administration; MKP – multiple ketamine + propofol administrations; C – saline + saline, 3 times; MKPR – MKP plus running exercise; CR – C plus running exercise; n=10 per group.

were deeply anesthetized and transcardially perfused with 4% paraformaldehyde in 0.1 M phosphate-buffered saline (PBS). The brains were removed, fixed in 4% paraformaldehyde for 8 h, and stored in 30% sucrose solution until sunk twice. Frozen coronal sections (30  $\mu$ m) through the hippocampus were cut, and 1 of every 6 consecutive sections (180  $\mu$ m apart) was collected for BrdU immunofluorescence [16]. Sections were first denatured by incubation in 2 N HCl (dissolved in 0.2% tritonX-100) for 45 min at 37°C and neutralized with 0.1 M boric acid (pH 8.5) for 10 min at room temperature (RT) and washed 3 times with 0.01 M PBS for 5 min between each step. Sections were blocked with 6% normal goat serum for 45 min at RT before incubation with primary antibody (Roche mouse-anti-BrdU, 1:200) in 1% normal goat serum overnight at 4°C. The following day, the sections were washed with PBS and incubated with secondary antibody (Jackson Alex Fluoro488-conjugated Affinipure goat-anti-mouse IgG, 1:200) for 1 h at RT. Fluorescence was detected with an upright fluorescence microscope (Japan, Leica CTr6000-10B-H). An observer who was blinded to group assignment was responsible for counting the number of BrdU+ cells at 200 $\times$  magnification. Total cell counts were divided by the total number of sections analyzed. Normalized values were representative of the entire dentate gyrus (DG).

### Statistical methods

Data were tested for normal distribution using the Shapiro-Wilk normality test. Statistical analysis was performed using

SAS version 9.2. Running distance, the results of open field behavior, and BrdU+ cells per section were analyzed by *t* test or 1-way and factorial design ANOVA followed by Tukey's multiple comparison whenever appropriate. Animal weight, Morris water maze behavior, and fear conditioning test results were analyzed by 1-way or factorial design ANOVA for repeated measures or mixed model regression followed by Tukey's post-hoc test. The probe test results from the Morris water maze were not normally distributed and are expressed as medians and interquartile ranges. Comparisons between groups were performed using the Kruskal-Wallis test followed by Dunn's multiple comparison procedure. Whenever possible, the number of comparisons was restricted to those necessary to test the hypotheses, *i.e.*, single anesthetic exposure versus multiple anesthetic exposures, running exercise versus non-running exercise, the interaction running-anesthesia treatment. All other data are expressed as mean $\pm$ standard error of the mean (SEM). Differences were considered statistically significant when  $P<0.05$ .

## Results

### Effects of anesthesia and running on body weight

Body weight was recorded every 10 days from P10 to P60. Statistical analysis revealed that there was a large effect of age on body weight (Proc mixed,  $P<0.01$ ). Weight increased with aging (Figure 2). Anesthesia (Proc mixed,  $F(2, 17)=0.08$ ,  $P=0.9214$ ) and wheel running (Proc mixed,  $F(1, 35)=0.05$ ,  $P=0.8249$ ) had no significant effect on weight gain. Intensity of exercise as measured by running distance did not differ between the MKPR and CR groups (342.4 $\pm$ 33.646 laps, 314.4 $\pm$ 34.167 laps,  $t=1.85$ ,  $P=0.0813$ ).

### Open field test

Table 1 shows the results of the open field test. The total distance traveled, resting time in the central zone, and average velocity did not differ between groups (ANOVA,  $P>0.05$ ), and no interaction between anesthesia exposure and running was observed (Factorial design ANOVA, all  $P>0.05$ ).

### Morris water maze

Figure 3 shows the effect of anesthesia on spatial memory. Rats in group MKP took significantly longer to find the platform than those in group C on day 2 (59.04 $\pm$ 14.33s vs. 47.54 $\pm$ 16.73s, Proc mixed,  $P<0.01$ ), with no difference between groups SKP and C. Latency did not differ between groups (SKP, MKP, C) on days 3 and 4. Total distance (repeated measures ANOVA,  $p=0.3728$ ) did not differ between groups (SKP, MKP, C). We conclude that multiple anesthesia exposures caused memory impairment in adult rats.

**Table 1.** Open field test.

Group	Distance traveled (cm)	Time in central zone (s)	Average velocity (cm/s)
SKP	3756.59±578.10	210.88±69.96	6.26±0.96
MKP	3402.98±370.32	213.84±72.57	5.67±0.62
C	3508.04±740.67	199.28±81.52	5.85±1.23
MKPR	3349.82±480.20	204.58±62.00	5.58±0.80
CR	3589.52±526.22	183.48±47.17	5.98±0.88

Data are presented as mean ±SEM. Group size: n=10. SKP – single ketamine + propofol administration; MKP – three ketamine + propofol administrations; C – saline + saline, three times; MKPR – MKP plus running exercise; CR – C plus running exercise.

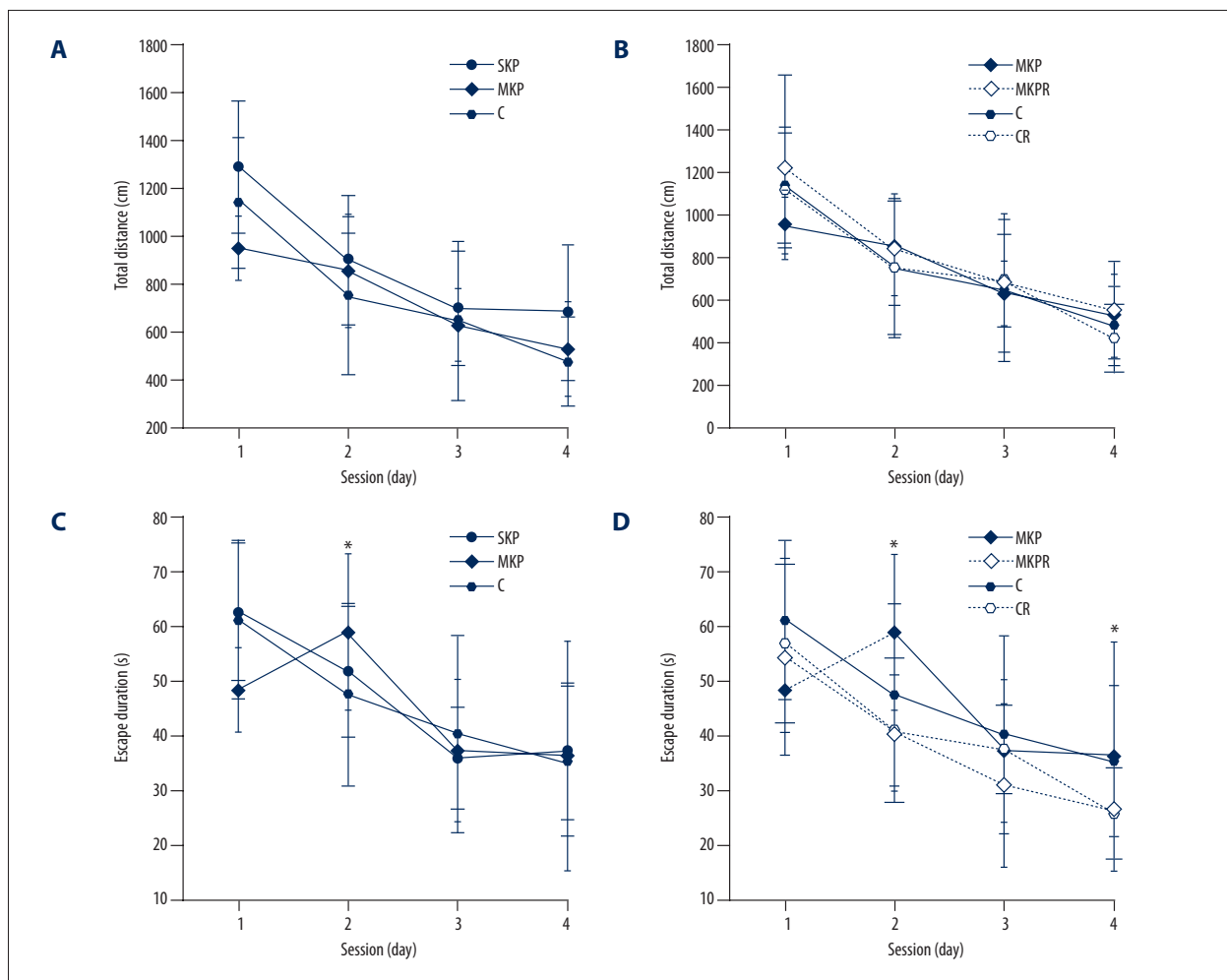
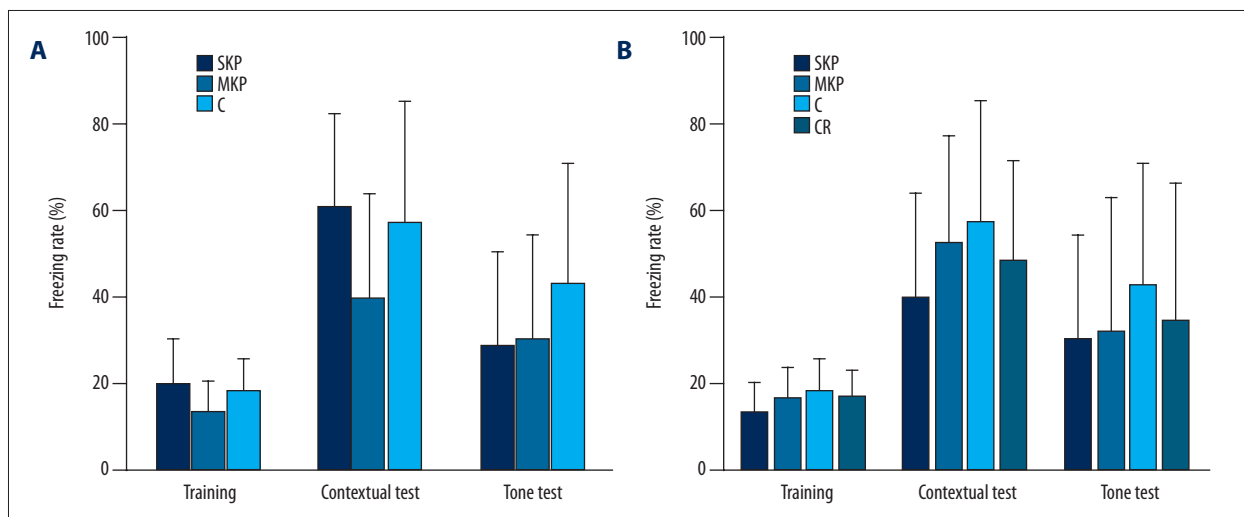

**Figure 3.** Spatial learning and memory after anesthesia exposure on P45. Rats received ketamine and propofol on postnatal days 6, 8, and 10 and were assessed for spatial learning and memory in the Morris maze. There was no difference in total distance between groups (A). MKP rats had shorter escape durations than rats in group C (\*  $P < 0.05$ , C). SKP – single ketamine + propofol administration; MKP – multiple ketamine + propofol administrations; C – saline + saline, three times; n=10/group. Spatial learning and memory after anesthesia exposure and wheel running. Rats received ketamine and propofol on postnatal days 6, 8, and 10, exercised for 10 days beginning on P21, and were assessed for spatial learning and memory in the Morris maze on P45. There was no difference in total distance between groups (B). Rats in the CR and MKPR groups had shorter latency than rats in groups C and MKP (\*  $P < 0.05$ , D). MKP – multiple ketamine + propofol administrations; C – saline + saline, three times; MKPR – MKP plus running exercise; CR – C plus running exercise.

**Table 2.** Probe trial.

Group	Time in target quadrant (s)	Times across the former platform (n)
SKP	31.26±8.90	1.90±0.74
MKP	19.4 (12.4, 25.2)*	1.67±1.00
C	26.12±9.44	2.01±0.64
MKPR	26.6 (22.1, 30.7)	1.40±1.70
CR	25.6 (23.6, 33.5)	0.99±0.31

Data are presented as mean ±SEM or median (interquartile range). Group size: n=10. \* P<0.05 vs. SKP. SKP – single ketamine + propofol administration; MKP – three ketamine + propofol administrations; C – saline + saline, three times; MKPR – MKP plus running exercise; CR – C plus running exercise.



**Figure 4.** The effects of anesthesia exposure and running on fear memory. Number of anesthesia exposures did not affect fear memory (A); adding running had no effect on performance (B). SKP – single ketamine + propofol administration, MKP – multiple ketamine + propofol administrations; C – saline + saline, 3 times; MKPR – MKP plus running exercise; CR – C plus running exercise; n=10/group.

As shown in Figure 3, 2×2 factorial design ANOVA (groups MKP, MKPR, C, and CR) revealed a statistically significant effect of running vs. non-running, but no interaction between running and anesthesia exposure. Rats in the MKPR and CR groups had shorter latencies on days 2 and 4 versus rats in the corresponding non-running groups (Repeated measures ANOVA, P=0.0081, 0.0336). The latency and total distance to find the platform in the MKP groups were similar to the control groups. The interaction of anesthesia exposure and running on latency and total distance did not reach significance (Repeated measure ANOVA, all P>0.05).

The probe trial revealed a strong effect of multiple anesthesia exposures (Table 2). SKP rats spent more time in the target quadrant than the MKP rats (Kruskal-Wallis test followed by Dunn's multiple comparison test, P=0.0062). Multiple anesthetic exposures did not affect the number of times rats crossed

the former platform (1-way ANOVA, P=0.3888). Factorial design indicated that running did not affect performance and was not affected by anesthesia exposure in the probe trial. These results suggest that running improved spatial memory, but did not reverse the memory impairment induced by multiple anesthetics.

#### Fear conditioning test

In the fear-conditioning test (Figure 4), freezing rate was higher in the contextual test than in the training and tone tests (all P<0.05). Multiple anesthetic exposures did not affect the freezing rate during the training, contextual, and tone tests (Repeated measure ANOVA, P=0.1448). Running had no effect (factorial design repeated measure ANOVA, P=0.9722) and no interaction with anesthesia exposure on fear memory (Factorial design repeated measure ANOVA, P=0.2717).



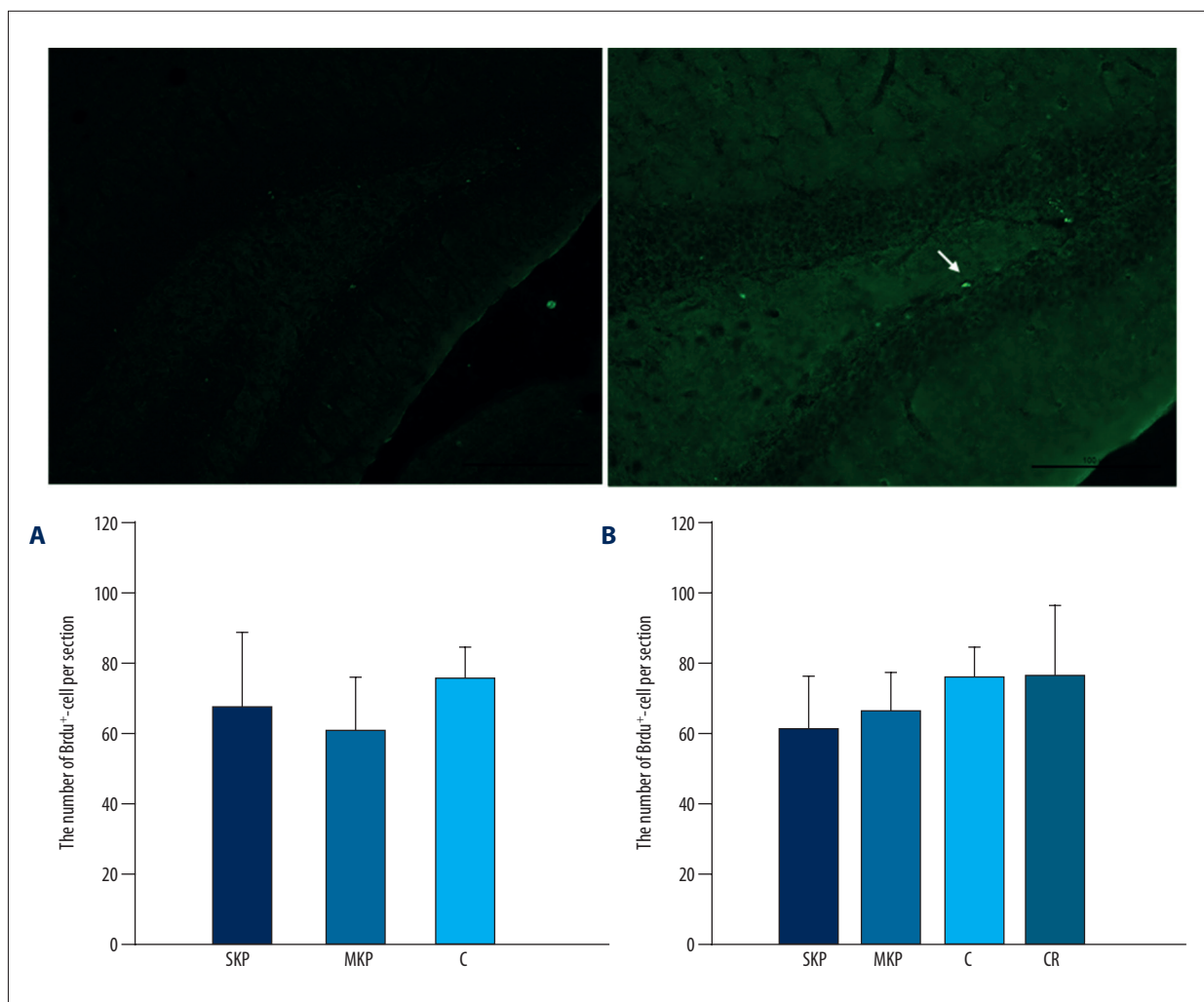

**Figure 5. (A, B)** Immunohistochemical labeling of hippocampus proliferation with bromodeoxyuridine (BrdU). BrdU(+) cells are indicated by arrows. Scale bar: 6a, 200 i.m.; 6b, 100 i.m. SKP – single ketamine + propofol administration, MKP – multiple ketamine + propofol administrations; C – saline + saline, 3 times; MKPR – MKP plus running exercise; CR – C plus running exercise; n=6/group.

### Effects of anesthesia and running on neurogenesis

In order to determine whether hippocampus neurogenesis was affected by anesthesia-induced neurotoxicity, rats in arm B were sacrificed to determine the numbers of new cells in the DG. Figure 5 shows BrdU staining in the DG and the mean number of BrdU+ cells per section. Kruskal-Wallis test revealed that the number of BrdU+ cells did not differ between groups (group SKP, MKP, C) with different times of anesthesia ( $P=0.1679$ ). Factorial design ANOVA indicated no significant difference in the number of BrdU+ cells in the running and non-running groups ( $P=0.6634$ ). Multiple anesthesia exposures (MKP, MKPR) had no effect on the number of BrdU+ cells versus the control groups (CR, C) ( $P=0.0658$ ). Running showed no interaction with anesthesia exposure ( $P=0.7483$ ).

### Discussion

We observed the behavioral effects of single or multiple anesthetic exposures with a combination of propofol and ketamine, and the effects of running exercise on anesthesia-induced memory impairment in rats. Our results indicated that multiple neonatal exposures to a combination of propofol 10 mg/kg (IP) and ketamine 25 mg/kg (SC) induced memory impairment; this effect was not observed after a single exposure. Our findings suggest running exercise could improve spatial memory in developing rats, but could not reverse memory impairment induced by multiple anesthesia exposures. We also failed to find a clear relationship between multiple anesthesia exposures and neurogenesis in the DG of the hippocampus.

## The effects of anesthesia on learning and memory

In developing animals, anesthetic-induced learning and memory impairment depends on species, dose, and duration [17]. In this study, single exposure of neonate rats to a combination of propofol and ketamine had no effect on spatial learning and memory in adulthood. In contrast, Fredriksson et al. showed that a single exposure to the same dose of propofol and ketamine led to functional deficits in adult mice [5]. We speculate that the following factors might contribute to the differences in our findings. First, the difference in species may contribute to the difference. It is possible that anesthesia does not induce neurotoxicity in advanced animal species. Clinical data suggest children who received multiple anesthesia exposures before the age of 4 years are at increased risk of developing learning disabilities in comparison to those who have undergone 1 or no surgical procedures [18]. In fact, the dose dependence of anesthesia-induced neurotoxicity has been confirmed in many previous studies, suggesting that limiting anesthetic exposure limits the potential for neurodegeneration [3,19]. The dose thresholds that cause anesthetic neurotoxicity in humans must be explored. Second, we administered propofol intraperitoneally, while Fredriksson used subcutaneous injection, although we do not know how the different delivery methods might influence the incidence of anesthesia-induced neurotoxicity. Third, the animals differed in age at the time of treatment: P6–10 versus P10. The vulnerability of regions responsible for learning might differ considerably over this age range. We also observed no effect of multiple anesthetics on fear memory. This might be related to selectivity, anesthetic-specificity, or dose-dependence of vulnerable learning and memory. Fear memory is more closely associated with the amygdala than with the hippocampus [20].

It is well known that hypoxia and hypotrophy can cause memory impairment [21,22]. To avoid this, we used the same doses of ketamine (25 mg/kg) and propofol (10 mg/kg) as described by Fredriksson et al., sufficient only to provide sedation and loss of the righting reflex rather than a surgical plane of anesthesia. All rats breathed smoothly without obvious cyanosis during the experimental period. Thus, the effects of hypoxia on learning and memory should be excluded, although we did not perform blood gas analysis to verify this. In addition, the nutritional state was evaluated based on body weight measured every 10 days. As shown in the results, anesthesia and running treatments had no impact on nutritional state.

## Running and anesthesia-induced learning and memory deficits

The mechanisms of anesthetic neurotoxicity are still unclear. Proposed mechanisms include neuro-apoptosis and impaired neurodevelopment processes such as neurogenesis and

synaptogenesis, which contribute to later learning and behavior impairment [8]. We must therefore explore methods to prevent or treat anesthesia-induced learning and memory impairment to improve the evidence for preclinical anesthetic neurotoxicity. The effects of some proposed neuroprotective strategies have been confirmed, although their mechanisms are unclear and none provided complete recovery. Environmental enrichment, as confirmed by Shih et al., fundamentally improves various aspects of brain function. In view of this, we tried to protect rats against anesthetic neurotoxicity by running, a method similar to environmental enrichment; both can improve neurogenesis. The rats in our study engaged in low-to-moderate intensity running exercise beginning on P21 (310–340 laps each day, equal to 8–10 m/min) [23]. As reported by Van Praag et al., running exercise improved performance in the Morris water maze test, but running did not reverse or treat memory impairment induced by multiple anesthesia exposures. This suggested that running might not have the same effect as environmental enrichment on anesthetic neurotoxicity. Usually, the environmental enrichment paradigm combines 3 major stimuli: physical exercise (running), social interaction, and environmental complexity [24]. Social interaction and environmental complexity might play important roles in learning and memory, and require further study. The environmental enrichment strategy may have additional positive effects on neurogenesis and thus lead to cognitive performance improvements by affecting hippocampus neurogenesis [25].

## The effect of anesthesia and running on neurogenesis

As a brain region associated with mammalian learning and memory after birth, proliferation and differentiation of stem cells in the DG of the hippocampus is important for hippocampal function [25]. Thousands of new neurons are added every day to the granule cell layer of the DG. Such continuous addition of new neurons is dependent upon the microenvironment. If the process is blocked by pharmaceuticals such as GABA<sub>A</sub> agonist propofol, and/or the NMDA antagonist ketamine, hippocampus-dependent learning and behavior in rodents is impaired. In this study, however, we failed to observe any effects of a low-dose combination of ketamine and propofol on hippocampal neurogenesis. Running exercise improved performance in the Morris water maze without obvious changes in neurogenesis. Many factors might contribute to these results. Previous studies have suggested that ketamine enhances human neural stem cell proliferation; in contrast, propofol inhibits proliferation in the DG of the hippocampus [26,27]. We therefore speculated that the combination of drugs offsets these effects and would have no significant effect on neurogenesis in the hippocampus. In addition, multiple mechanisms may mediate anesthetic neurotoxicity. Neurogenesis might not be causally associated with anesthetic-induced learning and memory impairment. Thus, running exercise improved rat achievement, but this is not necessarily associated with changes in neurogenesis. In



addition, we used a semi-quantitative method to detect proliferation [28] and this method may not reveal subtle changes.

### Limitations

Our study has some limitations. For instance, it is always difficult to translate drug dosages from rats to humans. It is also impossible to draw conclusions from animal studies regarding how drug combinations might affect long-term cognitive outcomes in human infants. We did not improve neurogenesis with running exercise, but these findings may not apply to higher-intensity exercise or a richer environment. Blood gases and pulse oximetry were not performed in this study, and we did not set a control for the SKP group, although this does not affect the conclusions of factorial analysis.

### Conclusions

Our findings confirmed our first hypothesis that multiple rather than single exposure to combined ketamine and propofol

anesthesia induced significant cognitive alterations in Sprague-Dawley rats. However, we failed to demonstrate the treatment or reverse effect of running exercise on anesthetic neurotoxicity. In addition, improved behavioral test results may not necessarily be attributed to changes in neurogenesis. The role of neurogenesis in anesthetic neurotoxicity requires further study, as our findings do not support definitive recommendations.

### Acknowledgement

The authors thank the Institute for Translational Medicine of Shanghai Children's Medical Center for providing laboratory space, the Pathology Department for tissue sectioning and technical assistance, and Shi-ling Deng for assistance with the behavioral tests.

### Conflict of interest

None.

### References:

- Rice D, Barone S Jr.: Critical periods of vulnerability for the developing nervous system: evidence from humans and animal models. *Environ Health Perspect.* 2000; 108(Suppl.3): 511–33
- Stratmann G. Review article: Neurotoxicity of anesthetic drugs in the developing brain. *Anesth Analg.* 2011; 113(5): 1170–79
- Jevtovic-Todorovic V, Hartman RE, Izumi Y et al: Early exposure to common anesthetic agents causes widespread neurodegeneration in the developing rat brain and persistent learning deficits. *J Neurosci.* 2003; 23(3): 876–82
- Liu J, Rossaint R, Sanders RD, Coburn M: Toxic and protective effects of inhaled anaesthetics on the developing animal brain: systematic review and update of recent experimental work. *Eur J Anaesthesiol.* 2014; 31(12): 669–77
- Fredriksson A, Ponten E, Gordh T, Eriksson P: Neonatal exposure to a combination of N-methyl-D-aspartate and gamma-aminobutyric acid type A receptor anesthetic agents potentiates apoptotic neurodegeneration and persistent behavioral deficits. *Anesthesiology.* 2007; 107(3): 427–36
- Olsen EA, Brambrink AM: Anesthetic neurotoxicity in the newborn and infant. *Curr Opin Anaesthesiol.* 2013; 26(5): 535–42
- Sanders RD, Hassell J, Davidson AJ et al: Impact of anaesthetics and surgery on neurodevelopment: an update. *Br J Anaesth.* 2013; 110(Suppl.1): i53–72
- Lei X, Guo Q, Zhang J: Mechanistic insights into neurotoxicity induced by anesthetics in the developing brain. *Int J Mol Sci.* 2012; 13(6): 6772–99
- Shih J, May LD, Gonzalez HE et al: Delayed environmental enrichment reverses sevoflurane-induced memory impairment in rats. *Anesthesiology.* 2012; 116(3): 586–602
- Kempermann G, Fabel K, Ehninger D et al: Why and how physical activity promotes experience-induced brain plasticity. *Front Neurosci.* 2010; 4: 189
- Lafenetre P, Leske O, Ma-Hogemeze Z et al: Exercise can rescue recognition memory impairment in a model with reduced adult hippocampal neurogenesis. *Front Behav Neurosci.* 2010; 3: 34
- Winocur G, Wojtowicz JM, Sekeres M et al: Inhibition of neurogenesis interferes with hippocampus-dependent memory function. *Hippocampus.* 2006; 16(3): 296–304
- Satoh Y, Endo S, Ikeda T et al: Extracellular signal-regulated kinase 2 (ERK2) knockdown mice show deficits in long-term memory; ERK2 has a specific function in learning and memory. *J Neurosci.* 2007; 27(40): 10765–76
- D'Hooge R, De Deyn PP: Applications of the Morris water maze in the study of learning and memory. *Brain Res Brain Res Rev.* 2001; 36(1): 60–90
- Satomoto M, Satoh Y, Terui K et al: Neonatal exposure to sevoflurane induces abnormal social behaviors and deficits in fear conditioning in mice. *Anesthesiology.* 2009; 110(3): 628–37
- Wojtowicz JM, Kee N: BrdU assay for neurogenesis in rodents. *Nat Protoc.* 2006; 1(3): 1399–405
- Reddy SV: Effect of general anesthetics on the developing brain. *J Anaesthesiol Clin Pharmacol.* 2012; 28(1): 6–10
- Wilder RT, Flick RP, Sprung J et al: Early exposure to anesthesia and learning disabilities in a population-based birth cohort. *Anesthesiology.* 2009; 110(4): 796–804
- Patel P, Sun L: Update on neonatal anesthetic neurotoxicity: insight into molecular mechanisms and relevance to humans. *Anesthesiology.* 2009; 110(4): 703–8
- Anagnostaras SG, Gale GD, Fanselow MS: Hippocampus and contextual fear conditioning: recent controversies and advances. *Hippocampus.* 2001; 11(1): 8–17
- Hemb M, Cammarota M, Nunes ML: Effects of early malnutrition, isolation and seizures on memory and spatial learning in the developing rat. *Int J Dev Neurosci.* 2010; 28(4): 303–7
- Rappaport BA, Suresh S, Hertz S et al: Anesthetic neurotoxicity-clinical implications of animal models. *N Engl J Med.* 2015; 372(9): 796–97
- Lou SJ, Liu JY, Chang H, Chen PJ: Hippocampal neurogenesis and gene expression depend on exercise intensity in juvenile rats. *Brain Res.* 2008; 1210: 48–55
- van Praag H, Kempermann G, Gage FH: Neural consequences of environmental enrichment. *Nat Rev Neurosci.* 2000; 1(3): 191–98
- Mongiat LA, Schinder AF: Adult neurogenesis and the plasticity of the dentate gyrus network. *Eur J Neurosci.* 2011; 33(6): 1055–61
- Erasso DM, Chaparro RE, Quiroga Del Rio CE et al: Quantitative assessment of new cell proliferation in the dentate gyrus and learning after isoflurane or propofol anesthesia in young and aged rats. *Brain Res.* 2012; 1441: 38–46
- Keilhoff G, Bernstein HG, Becker A et al: Increased neurogenesis in a rat ketamine model of schizophrenia. *Biol Psychiatry.* 2004; 56(5): 317–22
- Taupin P: BrdU immunohistochemistry for studying adult neurogenesis: paradigms, pitfalls, limitations, and validation. *Brain Res Rev.* 2007; 53(1): 198–214