

## Health Beneficial Effects of Food Factors Can Be Applicable to Humans?

Guest Editor: Kazuki Kanazawa

# Diurnal rhythmicity in biological processes involved in bioavailability of functional food factors

Takashi Tsurusaki,<sup>1</sup> Hiroyuki Sakakibara,<sup>1,\*</sup> Yoshiki Aoshima,<sup>2</sup> Shunsuke Yamazaki,<sup>2</sup> Masanobu Sakono,<sup>1</sup> and Kayoko Shimoi<sup>2</sup>

<sup>1</sup>Faculty of Agriculture, University of Miyazaki, 1-1 Gakuen Kibana-dai Nishi, Miyazaki 889-8526, Japan

<sup>2</sup>Graduate School of Integrated Pharmaceutical and Nutritional Sciences, University of Shizuoka, 52-1 Yada, Suruga-ku, Shizuoka 422-8526, Japan

(Received 30 November, 2012; Accepted 20 February, 2013; Published online 19 April, 2013)

In the past few decades, many types of functional factors have been identified in dietary foods; for example, flavonoids are major groups widely distributed in the plant kingdom. However, the absorption rates of the functional food factors are usually low, and many of these are difficult to be absorbed in the intact forms because of metabolism by biological processes during absorption. To gain adequate beneficial effects, it is therefore mandatory to know whether functional food factors are absorbed in sufficient quantity, and then reach target organs while maintaining beneficial effects. These are the reasons why the bioavailability of functional food factors has been well investigated using rodent models. Recently, many of the biological processes have been reported to follow diurnal rhythms recurring every 24 h. Therefore, absorption and metabolism of functional food factors influenced by the biological processes may vary with time of day. Consequently, the evaluation of the bioavailability of functional food factors using rodent models should take into consideration the timing of consumption. In this review, we provide a perspective overview of the diurnal rhythm of biological processes involved in the bioavailability of functional food factors, particularly flavonoids.

**Key Words:** bioavailability, diurnal rhythmicity, flavonoids, functional food factors, rodents

Dietary foods contain many types of components. Major and important components are nutrients essential to humans, including vitamins, fatty acids, amino acids, carbohydrates and minerals. Daily foods should contain all such essential nutrients and, additionally, sufficient calories to balance energy expenditure. Hence, daily amounts of essential nutrients (Dietary Reference Intakes) have been established in many countries including Japan.<sup>(1)</sup> The other components in the dietary foods are functional food factors; they are not essential, but their daily consumption, in addition to satisfaction of the Dietary Reference Intakes, is recognized to maintain homeostasis and exert several health benefits, for example, antioxidant, anti-inflammatory, anti-obesity, and anti-cancer actions.<sup>(2)</sup>

In the past few decades, many types of functional factors have been identified in dietary foods.<sup>(2,3)</sup> However, their absorption

rates are usually low, and many of these are difficult to be absorbed in the intact forms because of metabolism by biological processes before absorption. For example, flavonoid glycosides, which are widely distributed in the plant kingdom,<sup>(4)</sup> are well known to be absorbed after some modifications. Briefly, once consumed, flavonoid glycosides are usually hydrolyzed into the aglycone form by mucosal and bacterial enzymes in the digestive tract, and are subsequently metabolized into glucuronidated and sulfated derivatives via phase II reactions.<sup>(5)</sup> Additionally, the absorption ratio of flavonoid glycosides is reported to be low; around 1% of the consumption.<sup>(6,7)</sup> To gain adequate beneficial effects, it is therefore mandatory to know whether functional food factors are absorbed in sufficient quantity, and then reach target organs while maintaining beneficial effects. These are the reason why the bioavailability of functional food factors has been well investigated using animal models.<sup>(7-10)</sup>

Interestingly, recent studies have suggested that many of the biological processes in human displays an endogenous oscillation of about 24 h (circadian rhythm), which is converted to accurate 24 h diurnal rhythms by resetting the clock genes with light exposure and/or food consumption at morning (see the following section for further details). These biological processes include several parameters concerning in the absorption and metabolism of essential nutrients and drugs, and also the toxicity of environmental chemicals. Hence, beneficial and toxicological effects of many essential nutrients, drugs and environmental chemicals are reported to be largely different according to consumption, administration and exposure time, respectively.<sup>(11-15)</sup> Transporter-mediated glucose uptake was greater at active phase compared with the inactive phase in rat duodenum.<sup>(13)</sup> Moreover, the frequencies of the micronucleated peripheral reticulocytes in the bone marrow from mice exposed to *N*-ethyl-*N*-nitrosourea at active phase were significantly higher than those in mice treated at inactive phase, indicating that genotoxic sensitivity to chemicals is different between active and inactive phases.<sup>(15)</sup> This recent information shows the importance of knowing when to consume, administrate and expose target compounds, in addition to the

\*To whom correspondence should be addressed.  
E-mail: hiroyuki@cc.miyazaki-u.ac.jp

amounts of these factors. However, many animal studies performed to evaluate the bioavailability of functional food factors have not taken into consideration the timing of consumption. In this review, we provide a perspective overview of the diurnal rhythm of biological processes involved in the bioavailability of functional food factors, particularly flavonoids. Furthermore, the recent research topics involving several food factors that can affect circadian rhythm are focused.

### Oscillation of Clock-Related Genes

Circadian rhythms are produced by a complex transcriptional-translational feedback loop, which revolves about a 24 h cycle.<sup>(16,17)</sup> As shown in Fig. 1, the transcriptional regulators, circadian locomotor output cycles kaput (CLOCK) and brain and muscle ARNT-like protein 1 (BMAL1), form a heterodimer. The CLOCK/BMAL1 heterodimer is a positive regulator, and activates expression of genes with E-box in the promoter regions. These are generally called “clock-controlled genes (CCGs)”, and encode essential regulators of hormonal and metabolic pathway. Period (*Per*) mRNA and Cryptochrome (*Cry*) mRNA are major CCGs. The individual proteins, PER and CRY, make a complex (PER/CRY) that suppresses the transcription of its own genes by blocking the activity of CLOCK/BMAL1 heterodimer (negative feedback). Additionally, CLOCK/BMAL1 activates nuclear receptor subfamily 1, group D, member 1 (*Rev-erba*) and RAR-related orphan receptor  $\alpha$  (*Rora*), which regulate CLOCK and BMAL1 production via ROR responsive elements (RORE) in their promoters. This negative feedback loop revolves about a 24 h cycle, thereby resulting in free-run circadian rhythms, although these circadian rhythms are converted to accurate 24 h diurnal rhythms by resetting these clock genes with light exposure and/or food consumption at morning (around active phase).

The diurnal gene expression profiles consisted of the negative feedback loop; *Clock*, *Bmal1*, *Per1*, *Per2*, and *Cry1* on duodenum mucosa in mice were determined (Fig. 2A). The samples were

collected at 6 h intervals at 5 times from male C57BL/6 mice housed under a 12 h light/12 h dark cycle. These gene expressions suggested diurnal expression patterns; maximum expressions of *Bmal1* and *Clock* were located around the beginning of the light period, and *Per1*, *Per2* and *Cry* were around the beginning of the dark period, as similar results have been reported by other research groups.<sup>(18–20)</sup> Mice and rats are nocturnal animals and, hence, their active and inactive phases are in the dark period and light period, respectively. The diurnal rhythms observed in the clock genes and CCGs expressions in human and rodents suggest similar patterns,<sup>(21)</sup> although humans are usually diurnal, indicating biological rhythmicity is equiphase according to the active/inactive phases in both mammalian species.

### Oscillation of CCGs Involved in Bioavailability of Nutrients in Mice Intestine

The diurnal gene expression profiles in mice duodenum mucosa related to xenobiotic transporter P-glycoprotein, multidrug resistance 1 $\alpha$  (*Mdr1a*) and regulation of absorption, main hexose transporters sodium-glucose co-transporter 1 (*Sgt1*) and glucose transporter 5 (*Glut5*), and peptide transporter proton-coupled oligopeptide transporter 1 (*Pept1*) were further determined (Fig. 2B and C). Expression of all genes exhibited diurnal rhythmicity with peak expression preceding the end of the light period, before nutrient arrival, similarly to major CCGs, *Per1*, *Per2* and *Cry1*. These diurnal rhythmicity of genes involved in the bioavailability of nutrients in the peripheral organs are reported to be shifted by restricted feeding in the light period, but weak effects on restricted feeding in the dark period,<sup>(22)</sup> indicating that the CCGs in the peripheral organs might be reset accurately to a 24 h diurnal rhythm mainly by consumption of foods before the active phase, breakfast in case of humans. Interestingly, Hirao and colleagues<sup>(23)</sup> reported that balanced diets containing carbohydrates/sugars and proteins are good for restricted feeding-induced entrainment of the peripheral circadian clock, but these effect was weak when

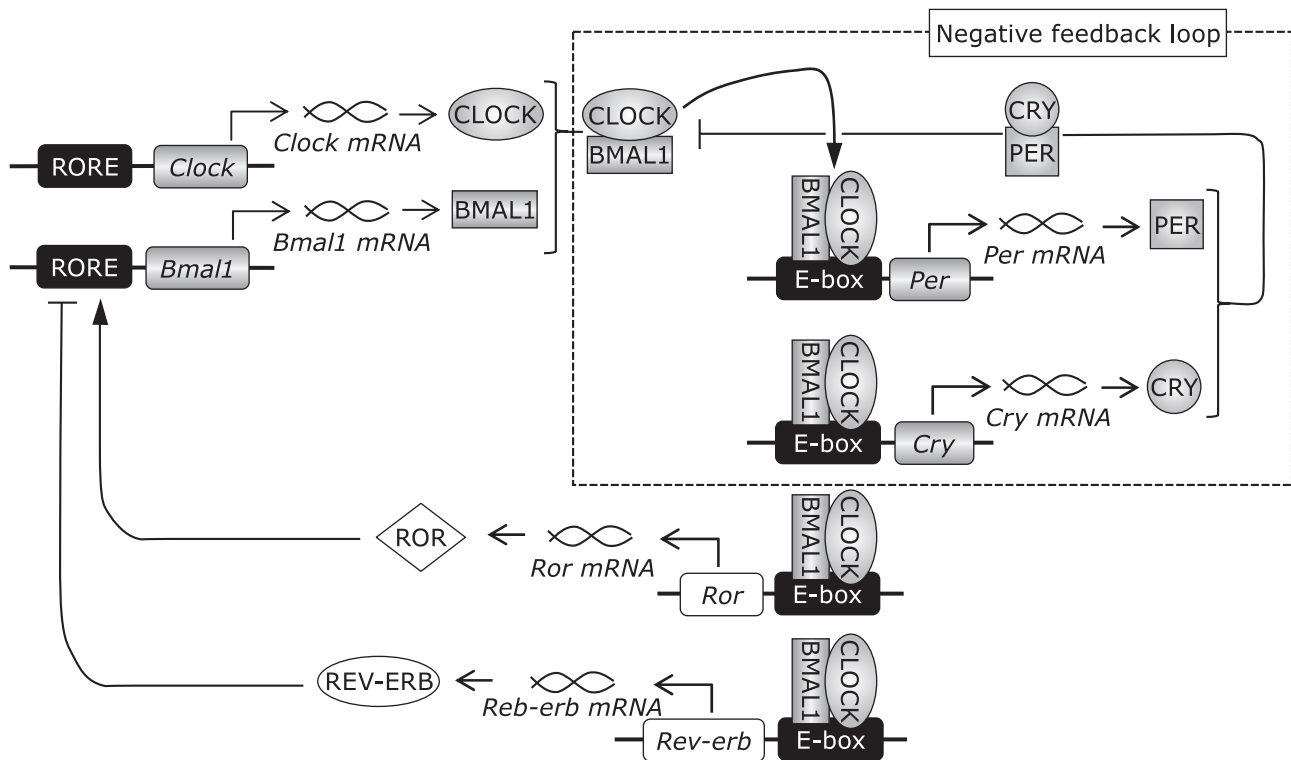
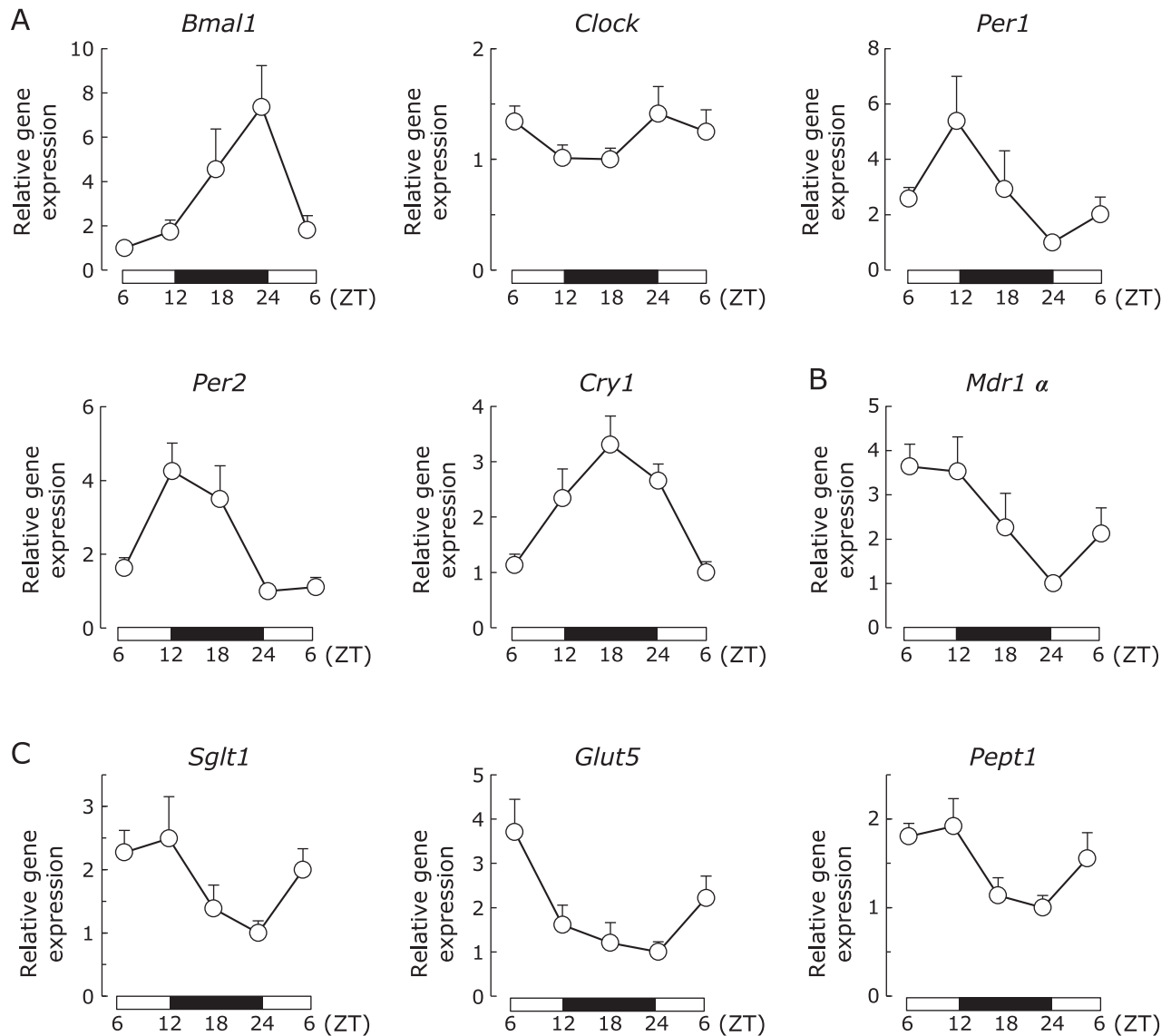

Fig. 1. The negative feedback loop responsible for circadian rhythm.

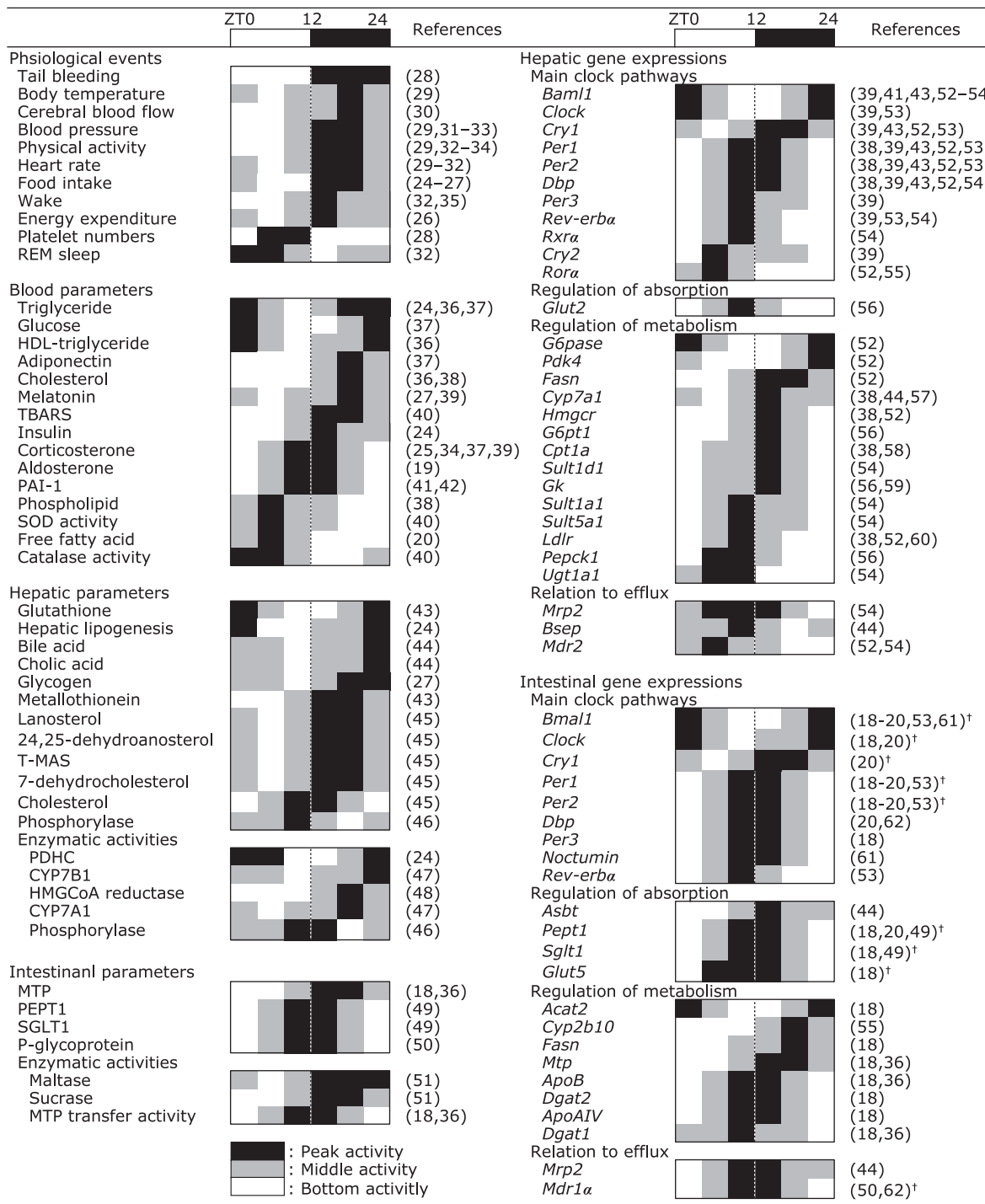

**Fig. 2.** Diurnal gene expression profiles of clock genes related to the negative feedback loop, xenobiotic transporter, regulation of absorption in duodenum mucosa in mice. Male C57BL/6 mice (4 weeks old) were acclimatized for 4 weeks in the animal-care room, which was controlled at  $23 \pm 1^\circ\text{C}$  and 60% humidity under a 12 h light/12 h dark cycle with *ad libitum* food consumption. Mice were anesthetized with ether at ZT0, 6, 12, 18, and 24 (0). "ZT" is an abbreviation of Zeitgeber time, with "ZT0" indicating the period when the light came on. Thus, the light period was from ZT0 to ZT12, and the dark period was from ZT12 to ZT24 (0). The duodenum (5 cm length from the stomach) was removed and the mucosa harvested. Total RNA was extracted and individual gene expression analyzed using quantitative real time reverse transcriptase polymerase chain reaction (qRT-PCR, PRISM7000, Applied Biosystems, Foster City, CA) according to our previous methods.<sup>(70)</sup> All primers used in this study were obtained from Applied Biosystems. (A) main clock pathway: *Bmal1* (Assay ID, Mm00500226\_m1), *Clock* (Mm\_00455950\_m1), *Per1* (Mm\_00501813\_m1), *Per2* (Mm\_00478113\_m1), *Cry1* (Mm\_00514392\_m1); (B) xenobiotic transporter P-glycoprotein: *Mdr1a* (Mm\_00440761\_m1); and (C) regulation of absorption: *Sglt1* (Mm\_00451203\_m1), *Glut5* (Mm\_00900311\_m1), *Pept1* (Mm\_00453524\_m1). This experiment was performed in accordance with the guidelines of the University of Shizuoka, Japan, for the Care and Use of Laboratory Animals, based on those of the American Association for Laboratory Animal Science. Individual abbreviations are summarized at the legends of Table 1. Mean bottom values are set at 1.0, and each data point indicates the mean  $\pm$  SE ( $n = 5$ ). The open bar at the bottoms indicates the light period (inactive phase), and the closed bar the dark period (active phase).

consuming sugar alone. They also suggested that the standard diet, for example AIN-93M formula, might be the suitable balanced diet for entrainment on mice. Rodents under *ad libitum* usually consume the diet on the beginning of dark period (active phase).<sup>(24–27)</sup> Therefore, the studies considering the diurnal rhythmicity of biological processes might be able to be performed by using nocturnal rodents with standard balanced diets such as AIN-93M *ad libitum*, and these results will be possible to extrapolate the human events.

### Diurnal Profiles of Biological Events, Parameters in Blood, Liver and Intestine, and Hepatic and Intestinal Expression of Genes Involved in Bioavailability of Functional Food Factors

Table 1 summarizes the recent knowledge of diurnal profiles of major biological events, parameters in blood, liver and intestine, and hepatic and intestinal expression of genes involved in the bioavailability of functional food factors, particularly dietary flavonoids, in rodents. As described above, intestinal mRNA



**Table 1.** Diurnal profiles of physiological events, parameters in blood, liver and intestine, and hepatic and intestinal expression of genes involved in bioavailability of functional food factors

Each column represents a circadian time point. Numbers at the top depict the time of day, and the bar represents the light phase (white) or dark phase (black). Peak activity and expression for each parameter is represented by the darkest region (■), middle activity and expression indicated by the gray region (▒), and lowest activity and expression indicated by the lightest region (□), summarizing with the indicated cited references (<sup>†</sup> indicating results suggested in this manuscript).

Abbreviations are: Acat, acyl-CoA cholesterol acyltransferase; Apo, apolipoprotein; Asbt, apical sodium-dependent bile acid transporter; Bmal1, brain and muscle arnt-like protein 1; Bsep, bile salt export pump; Clock, circadian locomotor output cycles kaput; Cpt1a, carnitine palmitoyltransferase 1a; Cry, cryptochrome; Cyp, cytochrome P450; Dbp, albumin D-element-binding protein; Dgat, diglyceride acyltransferase; Fasn, fatty acid synthase; G6pase, glucose 6-phosphatase; G6pt, glucose 6-phosphate transporter; Glut, glucose transporter; HMG-CoA reductase (Hmgcr), hydroxymethylglutaryl-CoA reductase; Ldlr, low density lipoprotein receptor; Mdr, multi-drug resistance; Mrp, multidrug-resistant protein; Mtp, microsomal triglyceride transfer protein; PAI-1, plasminogen activator inhibitor-1; PDHC, pyruvate dehydrogenase complex; Pdk4, pyruvate dehydrogenase kinase 4; Pepck1, phosphoenolpyruvate carboxykinase; Pept1, proton-coupled oligopeptide transporter 1; Per, period; Rora, retinoic acid receptor-related orphan receptor  $\alpha$ ; REM, rapid eye movement; Rev-erba, nuclear receptor subfamily 1, group D, member 1; Rxra, retinoic X receptor  $\alpha$ ; Sglt1, sodium-glucose co-transporter 1; SOD, superoxide dismutase; Sult, sulfotransferase; TBARS, thiobarbituric acid reactive substances; T-MAS, testicular meiosis-activating sterol; Ugt, UDP-glucuronosyltransferase.

expression, such as hexose transporters, peptide transporter, and xenobiotic transporter, exerts diurnal rhythms. Additionally, the mRNA levels involved in fat absorption; microsomal triglyceride transfer protein (*Mtp*) and apical sodium-dependent bile acid transporter (*Asbt*), also exert diurnal rhythms in a similar cycle.<sup>(18,36,44)</sup> Levels of intestinal proteins, such as SGLT1, PEPT1, MTP and P-glycoprotein, and the enzymatic activities of maltase, sucrose and MTP transfer exert diurnal patterns, with the maximum reached around the beginning of the dark period.<sup>(18,36,49,50)</sup> Concomitantly, uptake levels of not only nutrients, such as glucose and dipeptide, but also drugs, such as the antibiotic cefibuten and cardiac digoxin, are different depending on the administration period. Glucose and peptide uptakes are basically higher at the dark period (active phase) than the light period (inactive phase).<sup>(14,63,64)</sup> Additionally, diurnal variation in the intestinal accumulation of digoxin, a typical substrate of MDR1A, is reported by using mice intestinal *ex vivo* experiments.<sup>(50)</sup> According to that study, the diurnal accumulation of digoxin in intestine is nearly anti-phase to the rhythmicity of P-glycoprotein expression and *Mdr1a* gene expression. These results imply that the uptake and efflux of nutrients and drugs exert the administering time-dependent differences, because the biological processes, such as SGLT1 and MDR, have diurnal rhythmicity.

Although available data about the relations between the bioavailability of functional food factors and the timing of consumption have been limited yet, some studies suggest that the diurnal changes of biological process might be involved in the bioavailability. Gastric emptying time is an important factor affecting the absorption of functional food factors. When bilberry anthocyanins, which are the major flavonoids mainly in berry fruits,<sup>(65)</sup> were orally administered to C57BL/6 mice during the light or dark periods with same amounts, the gastric emptying time of anthocyanins was significantly faster upon administration at the dark period (active phase) than that of the light period (inactive phase) (Fig. 3). As described above, many types of functional food factors, particularly flavonoids are absorbed after some modifications, such as hydrolysis and conjugation, but not in intact forms. Gene expressions of many types of regulators involved in the metabolism of flavonoids follow a diurnal rhythm in rodents. As shown in Table 1, hepatic gene expression of sulfotransferases (*Sult1a1*, *Sult1d1*) and UDP-glucuronosyltransferase (*Ugt1a1*) are maximal around the change to the dark period.<sup>(54)</sup> The other pathways related to lipid and glucose metabolism also follow diurnal rhythms, including fatty acid synthase (*Fasn*), cytochrome P450 7a1 (*Cyp7a1*) and HMG-CoA reductase (*Hmgcr*) in the liver, and apolipoprotein (*ApoB* and *ApoAIV*) and diglyceride acyltransferase (*Dgat1* and *Dgat2*) in the small intestine.<sup>(18,36,38,44,52,57)</sup> These biological parameters are usually employed as the targets in order to evaluate the effects of functional food factors. Interestingly, the endogenous antioxidant system, such as superoxide dismutase (SOD) activity, is more active during the light period than the dark period in rodents.<sup>(40)</sup> Body temperature is another factor affecting enzymatic activities. Although all of mammals are homeothermic animals, body temperature has a diurnal rhythm; around 1.5°C higher during the middle of the dark period than during the middle of the light period in mice.<sup>(29)</sup> This difference might induce the stimulation of some enzymatic activities during the dark period.

### Effects of Functional Food Factors on Circadian Rhythms

Recently, some functional food factors have been reported to affect directly circadian rhythms. Oike and colleagues<sup>(66)</sup> reported that caffeine consumption *ad libitum* for a week lengthened the circadian locomotor rhythm in mice. Retinoic acid was suggested to significantly upregulate *Per1*, *Per2*, and peroxisome proliferator-activated receptor  $\alpha$  (*Ppara*) expression in an E-box-dependent manner using mouse NIH3T3 cells.<sup>(67)</sup> Another food

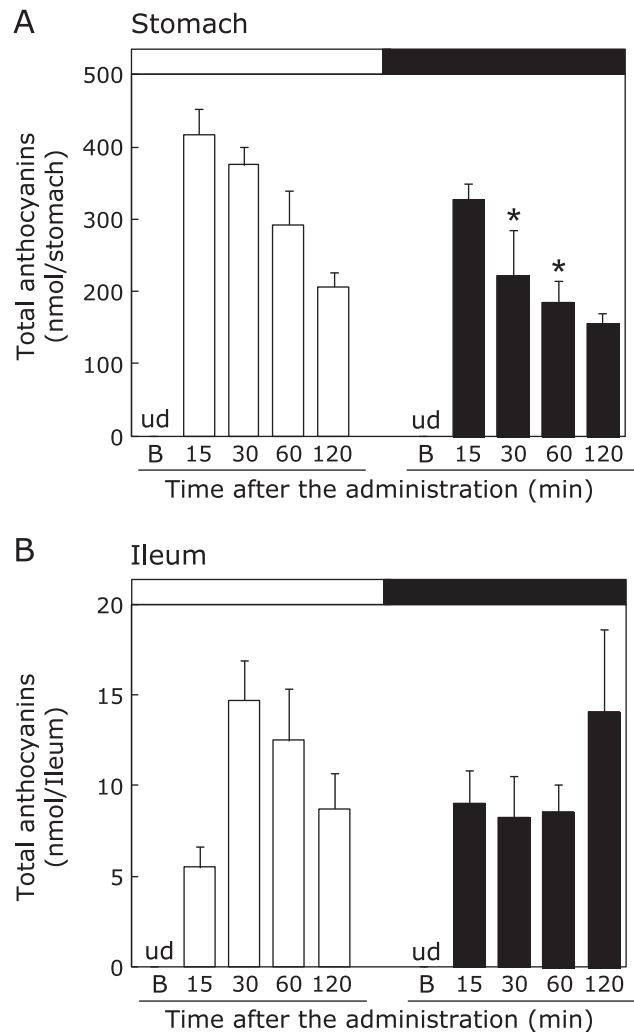

**Fig. 3.** Effects of administration period on gastric emptying time after oral administration of bilberry anthocyanin in mice. Male C57BL/6 mice (6 weeks old) were acclimatized for 2 weeks in the animal-care room with free access to tap water and purified diet. After 12 h of fasting, bilberry extracts obtained from Wakasa Seikatsu Co. Ltd., (Kyoto, Japan) were orally administered in amounts of 100 mg/kg body weight at ZT0 or ZT12. Animals were anesthetized with ether at individual time points, and the gastrointestinal tract was dissected into stomach and ileum (5 cm length from the blind gut). Tissue specimens were immersed immediately into 5 ml of 10% ice-cold citric acid, and then thoroughly dissected. After mixing at 2,500 rpm for 5 min, the sample solution was centrifuged at 3,000 rpm for 10 min, and 1.5 ml of the supernatant was evaporated to dryness using a centrifugal concentrator. The residue was dissolved in 300  $\mu$ L of methanol containing 0.5% trifluoroacetic acid and was subjected to high performance liquid chromatography analysis according to our previous method.<sup>(7)</sup> This experiment was performed in accordance with the guidelines of the University of Shizuoka, Japan, for the Care and Use of Laboratory Animals, based on those of the American Association for Laboratory Animal Science. Data indicate mean  $\pm$  SD ( $n = 5$ ) of total anthocyanins in the stomach (A) and ileum (B) at individual time points. The open bar indicates the administration at ZT0, and the closed bar was at ZT12. \*Significant differences vs same time point after the treatment at ZT0 ( $p < 0.05$ , Fisher-PLSD analysis). B, before the treatment at ZT0 or ZT12; ud, under the detection limits.

factor, resveratrol, a grape polyphenol, was found to upregulate expression of *Bmal1*, *Per1* and *Per2* mRNA in Rat-1 fibroblast cells.<sup>(68)</sup> These results suggest that several functional food factors affect the negative feedback loop shown in Fig. 1, and conse-

quently might change the bioavailability of themselves and/or other food factors consumed together via controlling of diurnal biological processes in the peripheral organs. The CCGs in the peripheral organs are recognized to be reset accurately to a 24 h diurnal rhythm mainly by consumption of foods, which are balanced diet, but not single ingredient, before the active phase as described above.<sup>(23)</sup> Furthermore, feeding stimulus for 30 min significantly induces the expression of *Per2* and *Dec 1* within 1 h, and alter the transcript levels and circadian phases of other clock genes (*Bmal1*, *Cry1*, *Per1*, and *Rev-erba*) in the liver at longer time intervals in rats.<sup>(69)</sup> By contrast, effects of balanced diet and functional food factors on the circadian rhythmicity remains poorly understood at human.

## Conclusion

Many biological processes involved in absorption and metabo-

lism of functional food factors follow the diurnal rhythm. Additionally, some functional food factors are suggested to affect directly the rhythms. Hence, the evaluation of the bioavailability of functional food factors should take into consideration the timing of consumption.

## Acknowledgments

The present study was supported in part by a Grant-in-Aid for Young Scientists (A) from the Japan Society for the Promotion of Science (No. 23310011, to H.S.), and Hokuto Foundation of Science and Technology (to H.S.).

## Conflict of interest

No potential conflicts of interest were disclosed.

## References

- Sasaki S. Dietary Reference Intakes (DRIs) in Japan. *Asia Pac J Clin Nutr* 2008; **17** (Suppl 2): 420–444.
- Shibamoto T, Kanazawa K, Shahidi F, Ho CT, eds. *Functional Food and Health, ACS Symposium Series 993*. Washington DC: ACS Publications, 2008; 1–514.
- Sakakibara H, Ashida H, Kanazawa K. A novel method using 8-hydroperoxy-2'-deoxyguanosine formation for evaluating antioxidative potency. *Free Radic Res* 2002; **36**: 307–316.
- Sakakibara H, Honda Y, Nakagawa S, Ashida H, Kanazawa K. Simultaneous determination of all polyphenols in vegetables, fruits, and teas. *J Agric Food Chem* 2003; **51**: 571–581.
- Terao J. Flavonols: metabolism, bioavailability, and health impacts. In: Fraga C, ed. *Plant Phenolics and Human Health*, Hoboken: John Wiley & Sons, Inc., 2010; 185–196.
- Anand P, Kunnumakkara AB, Newman RA, Aggarwal BB. Bioavailability of curcumin: problems and promises. *Mol Pharm* 2007; **4**: 807–818.
- Sakakibara H, Ogawa T, Koyanagi A, et al. Distribution and excretion of bilberry anthocyanins [corrected] in mice. *J Agric Food Chem* 2009; **57**: 7681–7686.
- Hashimoto T, Ueda Y, Oi N, et al. Effects of combined administration of quercetin, rutin, and extract of white radish sprout rich in kaempferol glycosides on the metabolism in rats. *Biosci Biotechnol Biochem* 2006; **70**: 279–281.
- Sakakibara H, Ashida H, Fukuda I, et al. A frequent drinking of green tea lowers the levels of endogenous oxidative stress in small intestines, erythrocytes and kidneys in rats. *J Clin Biochem Nutr* 2006; **39**: 32–39.
- Yokoyama A, Sakakibara H, Crozier A, et al. Quercetin metabolites and protection against peroxynitrite-induced oxidative hepatic injury in rats. *Free Radic Res* 2009; **43**: 913–921.
- Boughattas NA, Lévi F, Fournier C, et al. Circadian rhythm in toxicities and tissue uptake of 1,2-diamminocyclohexane(trans-1)oxalatoplatinum(II) in mice. *Cancer Res* 1989; **49**: 3362–3368.
- Pleschka K, Heinrich A, Witte K, Lemmer B. Diurnal and seasonal changes in sympathetic signal transduction in cardiac ventricles of European hamsters. *Am J Physiol* 1996; **270**: R304–R309.
- Houghton SG, Iqbal CW, Duenes JA, Fatima J, Kasperek MS, Sarr MG. Coordinated, diurnal hexose transporter expression in rat small bowel: implications for small bowel resection. *Surgery* 2008; **143**: 79–93.
- Pan X, Terada T, Okuda M, Inui K. Altered diurnal rhythm of intestinal peptide transporter by fasting and its effects on the pharmacokinetics of cefbuten. *J Pharmacol Exp Ther* 2003; **307**: 626–632.
- Itoh K, Masumori S, Nakajima M, Hayashi M, Sakakibara H, Shimoi K. Differences in micronucleus induction in peripheral blood reticulocytes of mice exposed to *N*-ethyl-*N*-nitrosourea at light and dark dosing times. *J Toxicol Sci* 2012; **37**: 427–430.
- Bellet MM, Sassone-Corsi P. Mammalian circadian clock and metabolism - the epigenetic link. *J Cell Sci* 2010; **123**: 3837–3848.
- Kagawa Y. From clock genes to telomeres in the regulation of the healthspan. *Nutr Rev* 2012; **70**: 459–471.
- Pan X, Hussain MM. Clock is important for food and circadian regulation of macronutrient absorption in mice. *J Lipid Res* 2009; **50**: 1800–1813.
- Soták M, Polidarová L, Musilková J, Hock M, Sumová A, Pácha J. Circadian regulation of electrolyte absorption in the rat colon. *Am J Physiol Gastrointest Liver Physiol* 2011; **301**: G1066–G1074.
- Saito H, Terada T, Shimakura J, Katsura T, Inui K. Regulatory mechanism governing the diurnal rhythm of intestinal H<sup>+</sup>/peptide cotransporter 1 (PEPT1). *Am J Physiol Gastrointest Liver Physiol* 2008; **295**: G395–G402.
- Akashi M, Soma H, Yamamoto T, et al. Noninvasive method for assessing the human circadian clock using hair follicle cells. *Proc Natl Acad Sci U S A* 2010; **107**: 15643–15648.
- Balakrishnan A, Stearns AT, Ashley SW, Tavakkolizadeh A, Rhoads DB. Restricted feeding phase shifts clock gene and sodium glucose cotransporter 1 (SGLT1) expression in rats. *J Nutr* 2010; **140**: 908–914.
- Hirao A, Tahara Y, Kimura I, Shibata S. A balanced diet is necessary for proper entrainment signals of the mouse liver clock. *PLoS One* 2009; **4**: e6909.
- Bryson JM, Cooney GJ, Wensley VR, Blair SC, Caterson ID. Diurnal patterns of cardiac and hepatic pyruvate dehydrogenase complex activity in gold-thiogluco-obese mice. *Biochem J* 1993; **295**: 731–734.
- Liu M, Shen L, Liu Y, et al. Diurnal rhythm of apolipoprotein A-IV in rat hypothalamus and its relation to food intake and corticosterone. *Endocrinology* 2004; **145**: 3232–3238.
- Sutton GM, Centanni AV, Butler AA. Protein malnutrition during pregnancy in C57BL/6J mice results in offspring with altered circadian physiology before obesity. *Endocrinology* 2010; **151**: 1570–1580.
- Weinert D, Freyberg S, Touitou Y, Djeridane Y, Waterhouse JM. The phasing of circadian rhythms in mice kept under normal or short photoperiods. *Physiol Behav* 2005; **84**: 791–798.
- Ohkura N, Oishi K, Sudo T, et al. CLOCK regulates circadian platelet activity. *Thromb Res* 2009; **123**: 523–527.
- Kim SM, Power A, Brown TM, et al. Deletion of the secretory vesicle proteins IA-2 and IA-2 $\beta$  disrupts circadian rhythms of cardiovascular and physical activity. *FASEB J* 2009; **23**: 3226–3232.
- Endo Y, Jinnai K, Endo M, Fujita K, Kimura F. Diurnal variation of cerebral blood flow in rat hippocampus. *Stroke* 1990; **21**: 1464–1469.
- Lemmer B, Arraj M. Effect of NO synthase inhibition on cardiovascular circadian rhythms in wild-type and eNOS-knock-out mice. *Chronobiol Int* 2008; **25**: 501–510.
- Sheward WJ, Naylor E, Knowles-Barley S, et al. Circadian control of mouse heart rate and blood pressure by the suprachiasmatic nuclei: behavioral effects are more significant than direct outputs. *PLoS One* 2010; **5**: e9783.
- Wang Q, Maillard M, Schibler U, Burnier M, Gachon F. Cardiac hypertrophy, low blood pressure, and low aldosterone levels in mice devoid of the three circadian PAR bZip transcription factors DBP, HLF, and TEF. *Am J Physiol Regul Integr Comp Physiol* 2010; **299**: R1013–R1019.
- Malisch JL, Breuner CW, Gomes FR, Chappell MA, Garland T Jr. Circadian pattern of total and free corticosterone concentrations, corticosteroid-binding globulin, and physical activity in mice selectively bred for high voluntary wheel-running behavior. *Gen Comp Endocrinol* 2008; **156**: 210–217.
- Sakakibara H, Romanowski CP, Jakubekova V, Flachskamm C, Shimoi K,

- Kimura M. Feeble awake effects of plasminogen activator inhibitor type-1 in mice. *Behav Brain Res* 2011; **220**: 354–357.
- 36 Pan X, Hussain MM. Diurnal regulation of microsomal triglyceride transfer protein and plasma lipid levels. *J Biol Chem* 2007; **282**: 24707–24719.
- 37 Rudic RD, McNamara P, Curtis AM, *et al.* BMAL1 and CLOCK, two essential components of the circadian clock, are involved in glucose homeostasis. *PLoS Biol* 2004; **2**: e377.
- 38 Yamajuku D, Okubo S, Haruma T, *et al.* Regular feeding plays an important role in cholesterol homeostasis through the liver circadian clock. *Circ Res* 2009; **105**: 545–548.
- 39 Zvonic S, Pitsyn AA, Conrad SA, *et al.* Characterization of peripheral circadian clocks in adipose tissues. *Diabetes* 2006; **55**: 962–970.
- 40 Subramanian P, Dakshayani KB, Pandi-Perumal SR, Trakht I, Cardinali DP. 24-hour rhythms in oxidative stress during hepatocarcinogenesis in rats: effect of melatonin or  $\alpha$ -ketoglutarate. *Redox Rep* 2008; **13**: 78–86.
- 41 Masuda Y, Emoto N, Nonaka H, *et al.* Role of angiotensin and the clock system in the circadian regulation of plasminogen activator inhibitor-1. *Kobe J Med Sci* 2009; **54**: E264–E271.
- 42 Oishi K, Ohkura N, Wakabayashi M, *et al.* CLOCK is involved in obesity-induced disordered fibrinolysis in ob/ob mice by regulating PAI-1 gene expression. *J Thromb Haemost* 2006; **4**: 1774–1780.
- 43 Xu YQ, Zhang D, Jin T, *et al.* Diurnal variation of hepatic antioxidant gene expression in mice. *PLoS One* 2012; **7**: e44237.
- 44 Zhang YK, Guo GL, Klaassen CD. Diurnal variations of mouse plasma and hepatic bile acid concentrations as well as expression of biosynthetic enzymes and transporters. *PLoS One* 2011; **6**: e16683.
- 45 Aćimović J, Košir R, Kastelec D, *et al.* Circadian rhythm of cholesterol synthesis in mouse liver: a statistical analysis of the post-squalene metabolites in wild-type and Crem-knock-out mice. *Biochem Biophys Res Commun* 2011; **408**: 635–641.
- 46 Roesler WJ, Khandelwal RL. The diurnal rhythm of liver glycogen phosphorylase: correlating changes in enzyme activity and enzymic protein. *FEBS Lett* 1986; **195**: 344–346.
- 47 Ren S, Marques D, Redford K, *et al.* Regulation of oxysterol 7 $\alpha$ -hydroxylase (CYP7B1) in the rat. *Metabolism* 2003; **52**: 636–642.
- 48 Edwards PA, Muroya H, Gould RG. *In vivo* demonstration of the circadian rhythm of cholesterol biosynthesis in the liver and intestine of the rat. *J Lipid Res* 1972; **13**: 396–401.
- 49 Pan X, Terada T, Irie M, Saito H, Inui K. Diurnal rhythm of H<sup>+</sup>-peptide cotransporter in rat small intestine. *Am J Physiol Gastrointest Liver Physiol* 2002; **283**: G57–G64.
- 50 Murakami Y, Higashi Y, Matsunaga N, Koyanagi S, Ohdo S. Circadian clock-controlled intestinal expression of the multidrug-resistance gene mdr1a in mice. *Gastroenterology* 2008; **135**: 1636–1644. e3.
- 51 Saito M, Suda M. Disaccharidase rhythm in rat small intestine; no relationship with mitosis rhythm. *Experientia* 1978; **34**: 700–701.
- 52 Oike H, Nagai K, Fukushima T, Ishida N, Kobori M. High-salt diet advances molecular circadian rhythms in mouse peripheral tissues. *Biochem Biophys Res Commun* 2010; **402**: 7–13.
- 53 Sládek M, Rybová M, Jindráková Z, *et al.* Insight into the circadian clock within rat colonic epithelial cells. *Gastroenterology* 2007; **133**: 1240–1249.
- 54 Zhang YK, Yeager RL, Klaassen CD. Circadian expression profiles of drug-processing genes and transcription factors in mouse liver. *Drug Metab Dispos* 2009; **37**: 106–115.
- 55 Gachon F, Olela FF, Schaad O, Descombes P, Schibler U. The circadian PAR-domain basic leucine zipper transcription factors DBP, TEF, and HLF modulate basal and inducible xenobiotic detoxification. *Cell Metab* 2006; **4**: 25–36.
- 56 Lamia KA, Storch KF, Weitz CJ. Physiological significance of a peripheral tissue circadian clock. *Proc Natl Acad Sci U S A* 2008; **105**: 15172–15177.
- 57 Wooton-Kee CR, Cohen DE, Vore M. Increased cholesterol 7 $\alpha$ -hydroxylase expression and size of the bile acid pool in the lactating rat. *Am J Physiol Gastrointest Liver Physiol* 2008; **294**: G1009–G1016.
- 58 Alenghat T, Meyers K, Mullican SE, *et al.* Nuclear receptor corepressor and histone deacetylase 3 govern circadian metabolic physiology. *Nature* 2008; **456**: 997–1000.
- 59 Duez H, van der Veen JN, Duhem C, *et al.* Regulation of bile acid synthesis by the nuclear receptor Rev-erba. *Gastroenterology* 2008; **135**: 689–698.
- 60 Le Martelot G, Claudel T, Gatfield D, *et al.* REV-ERB $\alpha$  participates in circadian SREBP signaling and bile acid homeostasis. *PLoS Biol* 2009; **7**: e1000181.
- 61 Douris N, Kojima S, Pan X, *et al.* Nocturnin regulates circadian trafficking of dietary lipid in intestinal enterocytes. *Curr Biol* 2011; **21**: 1347–1355.
- 62 Hayashi Y, Ushijima K, Ando H, *et al.* Influence of a time-restricted feeding schedule on the daily rhythm of abcb1a gene expression and its function in rat intestine. *J Pharmacol Exp Ther* 2010; **335**: 418–423.
- 63 Fatima J, Iqbal CW, Houghton SG, *et al.* Hexose transporter expression and function in mouse small intestine: role of diurnal rhythm. *J Gastrointest Surg* 2009; **13**: 634–641.
- 64 Qandeel HG, Duenes JA, Zheng Y, Sarr MG. Diurnal expression and function of peptide transporter 1 (PEPT1). *J Surg Res* 2009; **156**: 123–128.
- 65 Ogawa K, Sakakibara H, Iwata R, *et al.* Anthocyanin composition and antioxidant activity of the Crowberry (*Empetrum nigrum*) and other berries. *J Agric Food Chem* 2008; **56**: 4457–4462.
- 66 Oike H, Kobori M, Suzuki T, Ishida N. Caffeine lengthens circadian rhythms in mice. *Biochem Biophys Res Commun* 2011; **410**: 654–658.
- 67 Shirai H, Oishi K, Ishida N. Bidirectional CLOCK/BMAL1-dependent circadian gene regulation by retinoic acid *in vitro*. *Biochem Biophys Res Commun* 2006; **351**: 387–391.
- 68 Oike H, Kobori M. Resveratrol regulates circadian clock genes in Rat-1 fibroblast cells. *Biosci Biotechnol Biochem* 2008; **72**: 3038–3040.
- 69 Wu T, Ni Y, Kato H, Fu Z. Feeding-induced rapid resetting of the hepatic circadian clock is associated with acute induction of Per2 and Dec1 transcription in rats. *Chronobiol Int* 2011; **27**: 1–18.
- 70 Kido T, Sakakibara H, Ohura T, *et al.* Evaluation of chlorinated benz[a]anthracene on hepatic toxicity in rats and mutagenic activity in Salmonella typhimurium. *Environ Toxicol* 2013; **28**: 21–30.