

Evaluation of Recombinant Forms of the Shiga Toxin Variant Stx2eB Subunit and Non-Toxic Mutant Stx2e as Vaccine Candidates against Porcine Edema Disease

Toshio SATO^{1,3}), Takeshi MATSUI^{1,2}), Eiji TAKITA¹), Yumiko KADOYAMA^{1,3}), Sou-Ichi MAKINO⁴), Ko KATO²), Kazutoshi SAWADA¹) and Takashi HAMABATA³)*

¹)Advanced Technology Research Laboratories, Idemitsu Kosan Co. Ltd., 1280 Kamiizumi, Sodegaura, Chiba 299–0293, Japan

²)Graduate School of Biological Sciences, Nara Institute of Science and Technology (NAIST), 8916–5 Takayama, Ikoma, Nara 630–0101, Japan

³)Research Institute, National Center for Global Health and Medicine, 1–21–1 Toyama, Shinjuku, Tokyo 162–8655, Japan

⁴)Obihiro University of Agriculture and Veterinary Medicine Research Center, Obihiro, Hokkaido 080–8555, Japan

(Received 6 March 2013/Accepted 20 May 2013/Published online in J-STAGE 3 June 2013)

ABSTRACT. Porcine edema disease (ED) is a communicable disease of shoats caused by infection with Shiga toxin (Stx)-producing *Escherichia coli*. Stx2e is classified as a 1A5B-type toxin and is a decisive virulence determinant of ED. The single A subunit of Stx2e possesses enzymatic activity and is accompanied by a pentamer of B subunits, which binds to the host receptor and delivers the A subunit into the cell. In the present study, we used a mouse model to evaluate the immunogenicity of 3 ED vaccine candidates: a non-toxic mutant holotoxin mStx2e and 2 Stx2eB-based fusion proteins, Stx2eA₂B-His and Stx2eB-His. Systemic inoculation of mice with mStx2e- and the Stx2eB-derived antigens induced anti-Stx2e IgG responses that were fully and partially capable of neutralizing Stx2e cellular cytotoxicity, respectively. Intranasal immunization with mStx2e protected the mice from subsequent intraperitoneal challenge with a lethal dose of Stx2e, whereas immunization with Stx2eA₂B-His and Stx2eB-His afforded partial protection. Analysis of serum cytokines revealed that mStx2e, but not the Stx2eB-based antigens, was capable of inducing a Th2-type immune response. These results suggest that although the Stx2eB-based antigens elicited an immune response to Stx2e, they did so through a different mechanism to the Th2-type response induced by mStx2e.

KEY WORDS: component vaccine, neutralizing antibody, porcine edema disease, Stx2e.

doi: 10.1292/jvms.13-0118; *J. Vet. Med. Sci.* 75(10): 1309–1315, 2013

Shiga toxin (Stx)-producing *Escherichia coli* (STEC) causes a severe illness including hemorrhagic colitis and hemolytic-uremic syndrome in humans. STEC produces 2 types of toxin, Stx1 and Stx2, which have different immunological characteristics, but similar biological properties [29]. Several variants of Stx1 and Stx2 have been reported [20, 26], some of which are associated with infection in specific animals [28]. Porcine edema disease (ED) is an enterotoxemia of weaned piglets caused by STEC that produces Stx2e, a variant of Stx2. Intravenous injection of pigs with purified Stx2e causes clinical signs as well as gross and microscopic pathologic changes corresponding to ED [12]. However, pigs immunized with a genetically inactivated form of Stx2e developed a neutralizing antibody response [5]. Moreover, pigs vaccinated with an isogenic, avirulent STEC strain that produced genetically inactivated Stx2e were fully protected against subsequent challenge with a virulent STEC strain [13]. Collectively, these findings suggest that an Stx2e-based vaccine may be effective for the prevention of ED.

The Stx family toxins are structurally classified as 1A5B-type toxins, in which a single A subunit is associated with a homopentamer of B subunits [4], similar to the cholera toxin

(CT) of *Vibrio cholerae* and the heat-labile enterotoxin (LT) of enterotoxigenic *E. coli* [11]. The A subunit is composed of A₁ and A₂ fragments; A₁ enters the cytoplasm where it mediates the cytotoxic effects, whereas the A₂ fragment anchors the A₁ fragment to the B pentamer [25]. The B subunit binds to cell surface glycolipid receptors, Gb4 in the case of Stx2e [2], expressed on intestinal epithelial cells.

Although genetically inactivated mutant 1A5B holotoxins have recently become available, the B subunits are of greater interest as vaccine candidates for several reasons. First, the B subunits of all 1A5B toxins are intrinsically non-toxic [11] and, unlike holotoxins carrying point mutations, the B subunit could not revert to the native toxin. Second, inhibition of the interaction between B subunits and their cellular receptors is known to block the cytotoxic effects of the toxins. Moreover, substantial animal data indicate that vaccination with CTB or LTB subunits is safe and effective for the prevention of CT- or LT-associated diarrhea [7, 10]. The B subunits of Stx1 and Stx2 have also been reported to be immunogenic and proposed as candidate vaccine antigens [6, 14, 15]. In addition, the B subunit-encoding gene is much smaller than the holotoxin gene, which will be advantageous for producing of recombinant proteins by gene transduction into plant cells [16].

In the present study, we investigated the immunogenicity of 2 fusion proteins containing the Stx2eB subunit and compared their potential as ED vaccine candidates with that of a genetically inactivated Stx2e.

*CORRESPONDENCE TO: HAMABATA, T., Research Institute, National Center for Global Health and Medicine, 1–21–1 Toyama, Shinjuku, Tokyo 162–8655, Japan.

e-mail: thama@ri.ncgm.go.jp

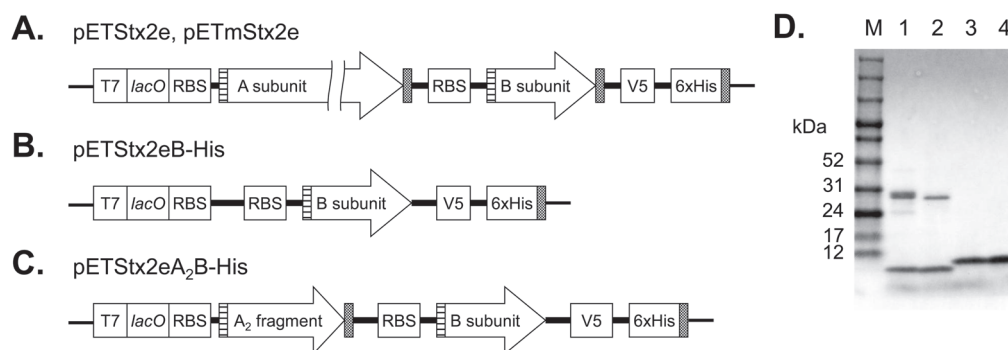

Fig. 1. Construction of expression plasmids for Stx2e and mStx2e (A), Stx2eB-His (B) and Stx2eA₂B-His (C). The schematic model shows the construction of a plasmid for the expression of target proteins. The arrow boxes indicate the open reading frames. The striped and shaded boxes indicate the start and stop codons, respectively. T7, T7 promoter; *lacO*, *lac* operator; RBS, ribosome-binding site; V5, V5 epitope tag; 6xHis, polyhistidine tag. (D) SDS-PAGE of the purified toxins and Stx2eB-derived antigens. Purified proteins (1 μ g) were resolved by 4–20% gradient SDS-PAGE and stained with Ez stain AQUA. Lanes 1 and 2 show the holotoxins of Stx2e and mStx2e, respectively. The 2 bands correspond to the A₁ fragment of the A subunit (27.3 kDa) and the B subunit (7.6 kDa). Lanes 3 and 4 show Stx2eA₂B-His and Stx2eB-His, respectively. The protein bands corresponding to the B subunit are slightly larger than the native B subunit, because of the additional 6xHis tag. The putative A₂ fragment of the A subunit (5.8 kDa) is not visible in the holotoxin or Stx2eA₂B-His samples. Lane M shows the molecular size markers.

Table 1. Primer pairs for construction of expression plasmids

Produced for	Primer sequences (5'–3')	Amplified from	Plasmid constructed
Stx2e	CACCATGAAGTGATATTGTAAAGTGGATCAGTTAAACTTCACCTGGGCAAAG	KY010	pETStx2e
mStx2e	CACCATGAAGTGATATTGTAAAGTGGATCAGTTAAACTTCACCTGGGCAAAG	YT106	pETmStx2e
Stx2eB-His	CACCAAGGAGTTAAGAATGAAGTTAAACTTCACCTGGGCAAAG	YT106	pETStx2eB-His
Stx2eA ₂ B-His	CACCGCGGTTCTGTTCGGTTAAACTTCACCTGGGCAAAG	YT106	pETStx2eA ₂ B-His

MATERIALS AND METHODS

Mice: BALB/c mice purchased from CLEA Japan (Tokyo, Japan) were maintained and bred in the experimental animal facility of the National Center for Global Health and Medicine (NCGM) under specific pathogen-free conditions. All mice were provided with food and water *ad libitum*. Eight-week-old female BALB/c mice were used in the experiments. All animal experiments were approved by the Animal Care and Use Committee of the NCGM and complied with the procedures of the Guide for the Care and Use of Laboratory Animals of NCGM.

Construction of *Stx2e*, *mStx2e*, *Stx2eB-His* and *Stx2eA₂B-His* expression plasmids: The genes encoding the wild-type *stx2e* and inactive *mstx2e* toxins were amplified from wild-type STEC strain KY010 and mutant STEC strain YT106 [13], respectively, by using polymerase chain reaction (PCR), which was performed with the primers listed in Table 1. The *stx2e* and *mstx2e* sequences were engineered to contain stop codons to allow expression of tag-free proteins. The fragments were ligated into the expression vector pET101/D-

TOPO (Fig. 1A), according to the manufacturer's instructions (Invitrogen, Life Technologies, Carlsbad, CA, U.S.A.). pET101/D-TOPO was also used to construct vectors for expression of 6xHis-tagged proteins. pETStx2eB-His was constructed by ligating the gene encoding the Stx2eB subunit, including the native ribosome-binding site (Fig. 1B). pETStx2eA₂B-His was constructed by ligating the sequence encompassing the A₂ fragment of the Stx2eA subunit and the Stx2eB subunit (Fig. 1C). The sequences were amplified from YT106 DNA by using the primers listed in Table 1. All plasmid constructs were verified by DNA sequencing.

***Stx2e* and *mStx2e* production and purification:** *E. coli* BL21 Star were transformed with pETStx2e and pETmStx2e and cultured in Luria-Bertani (LB) broth containing 50 μ g/ml ampicillin. Protein expression was induced by adding 0.5 mM isopropyl β -D-1-thiogalactopyranoside (IPTG) to the culture and incubating at 25°C for 24 hr with vigorous shaking. The cells were collected by centrifugation at 12,000 \times g for 15 min, and the pellet was resuspended in a volume of phosphate-buffered saline (PBS, pH 7.0) equivalent to 1.25% of the original culture volume. The resuspended cells

were lysed with a probe tip sonicator (Sonifier 250, Branson, Danbury, CT, U.S.A.), and cell debris was removed by centrifugation at $30,000 \times g$ for 20 min. The supernatant was chilled to 4°C, and solid ammonium sulfate was added to achieve 80% saturation. The resulting precipitate was collected by centrifugation at $30,000 \times g$ for 20 min at 4°C. The precipitate was dissolved in water to obtain the volume of the original supernatant, and the solution was dialyzed against 50 mM Tris-HCl (pH 8.6). The precipitate accruing from the dialysis was collected by centrifugation at $30,000 \times g$ for 20 min at 4°C and dissolved in 25 mM piperazine-HCl (pH 9.6). The resulting material was applied to a DEAE-Sephrose CL-6B (GE Healthcare, Uppsala, Sweden) column equilibrated with 25 mM piperazine-HCl (pH 9.6). The same buffer was applied to the column, and the flow-through fraction containing the purified toxin was collected. The purity of the toxins was checked by SDS-polyacrylamide gel electrophoresis (SDS-PAGE) with a 4–20% gradient gel under reducing and denaturing conditions. The gels were stained with Ez stain Aqua (ATTO, Tokyo, Japan).

Stx2eB-His and Stx2eA₂B-His protein production and purification: Production of Stx2eB-His was performed as described for Stx2e and mStx2e, except *E. coli* NovaBlue (Novagen, Merck KGaA, Darmstadt, Germany) were transformed with the plasmid pETStx2eB-His. For production of Stx2eA₂B, *E. coli* BL21 Star (DE3) were transformed with pETStx2eA₂B-His and cultured in Plusgrow broth (Nacalai Tesque, Kyoto, Japan) in the presence of ampicillin (50 µg/ml). The cells were collected by centrifugation and resuspended in a volume of buffer (1 M NaCl, 20 mM Tris-HCl, 5 mM imidazole, pH 7.9) equivalent to 4% of the original culture medium. Cells were lysed by a probe tip sonicator and centrifuged as described above. Stx2eA₂B-His was purified from the sonicate supernatant under non-denaturing conditions by using a His-bind kit (Novagen) according to the manufacturer's instructions, except the wash buffer used was 500 mM NaCl, 20 mM Tris-HCl and 100 mM imidazole, pH 7.9. The eluates were dialyzed against water by using a 10-kDa molecular weight cut-off (MWCO) dialysis membrane. The precipitate was removed by centrifugation, and the supernatant was concentrated using a 10-kDa MWCO ultrafiltration membrane (Millipore, Billerica, MA, U.S.A.). The purity of the proteins was checked by SDS-PAGE, as described above.

Systemic immunization of mice: On day 0, groups of 10 (mStx2e) and 5 (Stx2eB-His or Stx2eA₂B-His) mice were injected intraperitoneally (i.p.) with purified recombinant proteins (50 µg each of mStx2e, Stx2eB-His or Stx2eA₂B-His in 200 µl PBS), emulsified with 200 µl of Freund's complete adjuvant (Difco, Franklin Lakes, NJ, U.S.A.). Two booster injections of 10 µg protein in Freund's incomplete adjuvant were administered on days 14 and 28. Small volumes of blood were collected from the tail vein before immunization and on days 20 and 40 after immunization. The mice were sacrificed under anesthesia on day 43, and the total blood was collected from an abdominal vein. The blood samples were centrifuged at 4°C, and the sera were removed and frozen at -80°C until analysis of anti-Stx2e IgG titers

by endpoint dilution enzyme-linked immunosorbent assay (ELISA).

Mucosal immunization of mice and challenge with Stx2e toxin: Groups of 5 mice were intranasally (i.n.) administered 10 µg of mStx2e, Stx2eB-His or Stx2eA₂B-His at weeks 0, 2, 4, 6, 10 and 14. The mice were then anesthetized with sevoflurane (Maruishi Pharmaceutical, Osaka, Japan). A negative control group of mice was administered PBS i.n. Blood samples were collected from the mice before immunization and on days 60, 138 and 178 after immunization. Sera were prepared and stored as described above. Mice were observed for clinical signs and symptoms for 82 days after the last administration of mStx2e, Stx2eB-His or Stx2eA₂B-His and were then challenged i.p. with a lethal dose of Stx2e.

ELISA: Polystyrene 96-well plates (MaxiSorp, Nunc, Roskilde, Denmark) were coated with 0.25 µg of mStx2e per well. Serial dilutions of sera were prepared in PBS/0.05% Tween 20 (PBST) containing 10% bovine serum albumin (F-V, Nacalai Tesque), and aliquots were added to the wells. After incubation at 37°C for 1 hr, the wells were washed with PBST 3 times. Horseradish peroxidase-conjugated goat anti-mouse IgG (Zymed, San Francisco, CA, U.S.A.) was diluted 1:5,000 with PBST and applied 100 µl to each well as the secondary antibody. After incubation at 37°C for 1 hr, the wells were washed with PBST 3 times. Color development was performed by incubating the wells with 100 µl of citrate-phosphate buffer (pH 5.0) containing 0.03% (w/v) 2,2'-azino-bis(3-ethylbenzothiazoline-6-sulphonic acid (Nacalai Tesque) and 0.03% H₂O₂ (Santoku Chemical Industries, Tokyo, Japan) at r.t. for 1 hr, and the absorbance at 405 nm was measured spectrophotometrically. The antibody titer is expressed as the highest serum dilution to give an absorbance at least twice that of the background.

Vero cell assay: Vero cells were resuspended in Eagle's minimum essential medium (E-MEM) (Wako, Osaka, Japan) supplemented with 2 mM L-glutamine (Invitrogen), 10% fetal bovine serum (Thermo Fisher Scientific, Waltham, MA, U.S.A.), 100 IU/ml of penicillin (Nacalai Tesque) and 100 µg/ml of streptomycin (Nacalai Tesque) and seeded at 2×10^4 cells/100 µl/well in 96-well plates. The cells were cultured in an atmosphere of 5% CO₂ and 90% humidity at 37°C for 2 days until they reached confluence. The cells were then exposed to serially diluted, filter-sterilized Stx2e toxin and incubated for 4 days at 37°C in a CO₂ incubator. Next, 10 µl of CCK-8 solution (Cell Counting Kit-8; Dojindo Laboratories, Kumamoto, Japan) was added to each well, and the plate was incubated for 3 hr at 37°C. The absorbance at 450 nm was measured spectrophotometrically, and cell viability was calculated. The absorbance of cells incubated without toxin was taken as 100% viability. A 50% cytotoxic dose (CD₅₀) of Stx2e was defined as the maximum dilution producing a cytotoxic effect on $\geq 50\%$ of the cells in each well.

For toxin-neutralization assays, the sera were inactivated by incubation at 56°C for 30 min, serially diluted with E-MEM and added to wells containing Vero cells at confluence. Next, a concentration of Stx2e equivalent to $4 \times CD_{50}$ was added to each well, and the cells were incubated for 4

Table 2. Antibody titers of specific IgG against Stx2e in the sera of mice i.p. immunized with mStx2e, Stx2eA₂B-His and Stx2eB-His

Antigen	Days after immunization	Anti-Stx2e IgG titer	
		Mean	SD ^{a)}
mStx2e	0	N.D. ^{b)}	
	20	3.1×10^5	2.2×10^5
	40	4.4×10^5	1.7×10^5
	43	3.7×10^5	1.9×10^5
Stx2eA ₂ B-His	0	N.D.	
	20	1.5×10^4	1.1×10^4
	40	1.1×10^5	9.3×10^4
	43	1.1×10^5	9.3×10^4
Stx2eB-His	0	N.D.	
	20	1.6×10^4	1.1×10^4
	40	2.0×10^5	7.0×10^4
	43	2.0×10^5	7.0×10^4

a) Standard deviation. b) Not detected.

days at 37°C in a CO₂ incubator. The cell viability was then determined as described above. The Stx2e-neutralizing ability was expressed as an effective dose 50% (ED₅₀), defined as the maximum dilution producing a neutralizing effect on ≥50% of the toxicity in each well.

Cytokine analysis: Cytokine concentrations in mouse sera were measured with a Milliplex MAP Multiplex Assay kit (Millipore) and a Luminex 100 system (Luminex, Austin, TX, U.S.A.), according to the manufacturers' instructions. The cytokines analyzed were IL-2, IL-4, IL-5, IL-10, IL-12 (p70), IL-17, GM-CSF, IFN-γ and TNF-α.

Statistical analysis: To compare the results obtained among different groups of mice, statistical analysis was performed using Student's *t*-test.

RESULTS

Expression and purification of the toxin antigens: Toxin genes (*stx2e* and *mstx2e*) containing stop codons were cloned in-frame into the pET101 vector, which enabled expression as tag-free toxins (Fig. 1A). Stx2e and mStx2e behaved identically during expression and purification, although they differ at two amino acids (E167Q and R170L in mStx2e) [5]. The Stx2e and mStx2e proteins precipitated from the crude extract during dialysis at pH 8.6, which allowed partial purification and enrichment of the toxins. The toxins were further purified by application to DEAE-Sepharose CL-6B columns, which retained most of the impurities and allowed the toxins to be recovered in the flow-through. Following dialysis, the protein purity was checked using SDS-PAGE (Fig. 1D). The results of Vero cell assay indicated that the CD₅₀ of the Stx2e was 177 pg/ml, whereas the CD₅₀ of the mStx2e was essentially at background levels, as expected.

We initially constructed the expression vectors for Stx2eB or Stx2eA₂B with the V5 epitope and 6xHis tag at the N-termini of the fusion proteins, but the expressed proteins were not water-soluble. In contrast, placement of the tag sequences at the C-termini of the *stx2eB* or *stx2eA₂B*

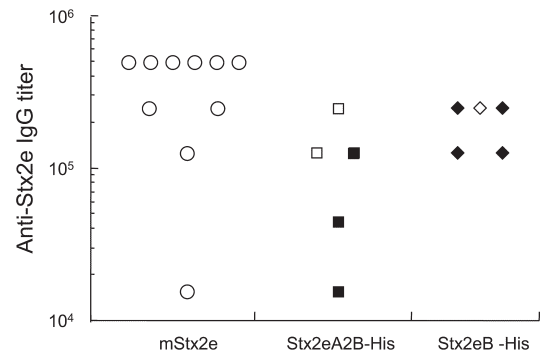

Fig. 2. Anti-Stx2e IgG titer and lethal toxin-neutralization activity in sera from individual mice immunized i.p. with mStx2e (●), Stx2eA₂B-His (■) and Stx2eB-His (◆). All serum samples from immunized mice on day 43 were assessed for anti-Stx2e IgG titer as well as ED₅₀ titer. Open symbols indicate sera that gave ED₅₀ titers ≥ 2, which was the cut-off for positive Stx2e-neutralizing activity.

sequences (Fig. 1B and 1C) allowed the production of fusion proteins with aqueous solubility. The purified proteins were concentrated with a 10-kDa MWCO ultrafiltration membrane, which removed the monomeric Stx2eB subunits (~7.8 kDa) [26], but retained the pentameric Stx2eB form. Thus, both Stx2eA₂B-His and Stx2eB-His remained in the concentrate and were not detected in the filtrate (data not shown). Stx2eA₂B-His and Stx2eB-His were soluble at concentrations of 1.5 mg/ml, but insoluble sediments formed at higher concentrations. The purified toxins were analyzed using SDS-PAGE (Fig. 1D), which showed that the samples were free of visible protein contamination. The existence of A₂ fragment in the purified Stx2eA₂B-His sample was confirmed by immunoblotting of synthesized A₂ peptide with antiserum against Stx2eA₂B-His (data not shown).

Induction of neutralizing antibodies by systemic immunization with mStx2e, Stx2eA₂B-His and Stx2eB-His: To determine whether the purified proteins were immunogenic following systemic administration, we injected the mice i.p. with mStx2e, Stx2eA₂B-His and Stx2eB-His and tested the sera prepared on days 20 and 40 post-immunization for anti-Stx2e- and Stx2eA₂B-specific antibodies by using ELISA. Elevated antibody titers were detected in the first bleed. As shown in Table 2, the mean anti-Stx2e IgG titers from the mStx2e-, Stx2eA₂B-His- and Stx2eB-His-immunized mice on day 20 were 3.1×10^5 (range, ×250 to ×512,000), 1.5×10^5 (range, ×250 to ×32,000) and 1.6×10^5 (range, ×250 to ×32,000), respectively. On day 40, the mean anti-Stx2e IgG titers from the mStx2e- and Stx2eB-His-immunized mice reached 4.4×10^5 (range, ×16,000 to ×512,000) and 2.0×10^5 (range, ×128,000 to ×256,000), respectively. The mean titer of Stx2eA₂B-His-immunized mice was 1.1×10^5 (range, ×16,000 to ×256,000), which was significantly lower than that of mStx2e-immunized mice ($P=0.001$).

We next investigated the ability of antibodies to neutralize Stx2e cytotoxicity in Vero cells. As shown in Fig. 2, all sera collected from mStx2e-immunized mice exhibited neutral-

Table 3. Antibody titers of specific IgG against Stx2e in the sera of mice i.n. immunized with mStx2e, Stx2eA₂B-His and Stx2eB-His

Antigen	Days after immunization	Anti-Stx2e IgG titer	
		Mean	SD ^{a)}
mStx2e	0	N.D. ^{b)}	
	60	1.5×10^3	7.1×10^2
	138	1.3×10^4	0
	178	3.3×10^4	1.7×10^4
Stx2eA ₂ B-His	0	N.D.	
	60	2.5×10^2	3.5×10^2
	138	8.1×10^1	1.8×10^2
	178	9.6×10^2	1.3×10^3
Stx2eB-His	0	N.D.	
	60	N.D.	
	138	4.1×10^1	8.9×10^1
	178	1.6×10^2	1.5×10^2

a) Standard deviation. b) Not detected.

izing activity against Stx2e-induced cytotoxicity with ED₅₀ titers ranging from $\times 4$ to $\times 128$. In contrast, not all of the Stx2eA₂B-His- and Stx2eB-His-immunized mice generated neutralizing antibodies; sera from 2 of the 5 Stx2eA₂B-His-immunized mice had ED₅₀ titers of $\times 8$, and sera from 1 of the 5 Stx2eB-His-immunized mice had an ED₅₀ titer of $\times 2$. There was no significant correlation between the Stx2e-neutralizing activity and the anti-Stx2e IgG titer (data not shown).

Protection of mice against Stx2e challenge by mucosal immunization with mStx2e, Stx2eA₂B-His and Stx2eB-His: We next investigated the immunogenicity of proteins administered by the mucosal route and determined whether the elicited antibodies could protect animals from a lethal dose of Stx2e. Table 3 shows the time course of anti-Stx2e IgG production following i.n. administration of proteins. The mean Stx2e-specific IgG titers from the mStx2e-immunized mice increased to 3.3×10^4 at day 178, while the mean titers of the Stx2eA₂B-His- and Stx2eB-His-immunized mice were 9.6×10^2 and 1.6×10^2 at day 178, respectively. All mice immunized with mStx2e and Stx2eA₂B-His developed Stx2e-specific IgG, while an IgG response was observed only in 3 of the 5 Stx2eB-His-immunized mice.

To determine whether the antibodies elicited by i.n. immunization conferred protective immunity, the mice were challenged i.p. with a lethal dose of Stx2e (0.1 μ g/mouse, data not shown) on day 180, i.e., 82 days after the final immunization. As shown in Fig. 3A, all of the mStx2e-immunized mice were protected from the Stx2e challenge, and by contrast, none of the non-immunized mice survived. Interestingly, the Stx2eA₂B-His- and Stx2eB-His-immunized mice showed intermediate protection profiles with survival rates of 20% (1 of 5 mice) and 40% (2 of 5 mice), respectively. There was no correlation between the Stx2e-specific antibody titer and the degree of protection (Fig. 3B). All mice alive on day 10 remained healthy at least until day 30 (data not shown).

Induction of differing cytokine responses following Stx2e challenge in mucosally immunized mice: To evaluate the

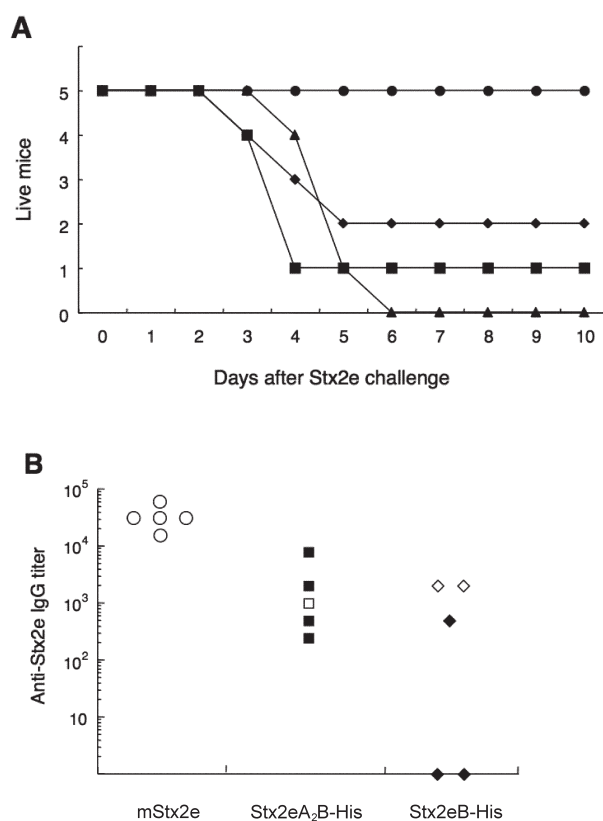

Fig. 3. A. Survival profile of mice immunized i.n. with mStx2e (●), Stx2eA₂B-His (■) or Stx2eB-His (◆), after i.p. injection with 0.1 μ g of the native toxin Stx2e. Mice administered PBS (▲) were used as negative controls. B. Anti-Stx2e IgG titers in individual sera and protection from lethal toxin challenge for mice immunized i.n. with mStx2e (●), Stx2eA₂B-His (■) and Stx2eB-His (◆). All serum samples from immunized mice on day 178 were assessed for anti-Stx2e IgG titer. Open symbols represent sera from protected mice.

cytokine response in mucosally immunized mice, a panel of cytokines was measured in sera collected from 5 mice in each group before and 3 days after the toxin challenge.

Before the challenge, the serum cytokine levels did not differ significantly between the immunized and non-immunized mice (data not shown). The fold changes in serum cytokine levels after immunization are summarized in Fig. 4. All of the mice immunized with mStx2e had significantly increased serum concentrations of IL-10, IL-12 and IL-4, but there were no changes in the remaining cytokines tested; namely IL-2, IL-5, IL-17, GM-CSF, IFN- γ and TNF- α (data not shown). In contrast, none of the Stx2eA₂B-His-, Stx2eB-His- and non-immunized mice showed increases in the cytokines tested, and in some cases, the concentrations decreased after immunization. There were no changes in the anti-Stx2e IgG titers (data not shown).

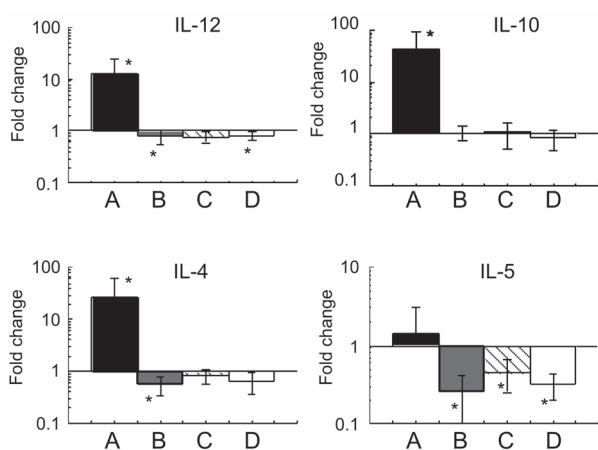

Fig. 4. Cytokines in the sera of Stx2e-challenged mice. Five mice per group were immunized with mStx2e (A), Stx2eA₂B-His (B), Stx2eB-His (C) or PBS (D). Sera were collected before and three days after lethal challenge with Stx2e. Concentrations of IL-10, IL-12, IL-4 and IL-5 before and after Stx2e challenge are shown as log₁₀-fold change \pm standard deviations (SD). Levels of IL-2, IL-17, GM-CSF, IFN- γ and TNF- α were unchanged and are not shown. An asterisk denotes significance at $P < 0.05$ for differences in cytokine concentrations before and after challenge.

DISCUSSION

In the present study, we purified native and mutant Stx2e using a modification of a previously described procedure [23]. The advantage of our simplified procedure is that we eliminated 2 labor-intensive steps, cation-exchange column fractionation and chromatofocusing. The integrity of the purified toxins was confirmed by SDS-PAGE. The CD₅₀ of the purified Stx2e in the Vero cell assay was 177 $\mu\text{g}/\text{ml}$, and the lethal dose was 13 ng/mouse (data not shown). These data are in accordance with a previous report [26], substantiating the validity of our purification method. The purified mStx2e was non-toxic, but immunogenic. Moreover, animals immunized with mStx2e produced Stx2e-specific neutralizing antibodies.

Because the A₂ fragment of Stx1 was previously reported to be necessary for holotoxin integrity [1], we constructed an Stx2eA₂B-His fusion protein and compared its immunogenicity in mice with that of Stx2eB-His. The 2 proteins elicited almost identical antibody titers with similar neutralizing activity, suggesting that the presence of Stx2eA₂ fragment did not affect the antigenicity of the Stx2eB.

Although the mice immunized i.p. with mStx2e, Stx2eA₂B-His and Stx2eB-His developed similar anti-Stx2e titers, the neutralizing activity of the sera was quite different. Whereas sera from the mStx2e-immunized mice showed complete neutralization, the sera from the mice immunized with Stx2eB-based antigens were only partially neutralizing. Similarly, i.n. immunization with all 3 proteins elicited Stx2e-specific antibodies. However, although all of the mStx2e-immunized mice were protected from a lethal Stx2e

challenge, only some of the Stx2eB-His- and Stx2eA₂B-His-immunized mice survived. Notably, the Stx2e-specific antibody titer did not correlate with survival (Fig. 3B), suggesting that protection was dependent on the neutralizing activity of the elicited antibodies. Actually, a monoclonal antibody 11E10 against Stx2A₁ was reported to neutralize the toxicity of Stx2 [24], which might explain the partial neutralization of Stx2eB-based antigens lacking A₁ subunit.

The cytokine assay was conducted to examine the difference of the secondary immunoresponse against the toxin challenge among each vaccinated group. We found that i.n. immunization with mStx2e significantly increased the serum levels of IL-10, IL-12 and IL-4 and enhanced the level of IL-5 after toxin challenge (Fig. 4). These cytokines are characteristic of Th2-type immune responses, suggesting that mStx2e immunization induced a Th2-, rather than a Th1-oriented immune response [21]. This response is similar to that of i.n. administered non-toxic Stx1 derivatives [19]. By contrast, the Stx2eB-based antigens appear to lack the ability to induce a secondary Th2 cytokine response after Stx2e challenge, probably due to insufficient primary immunostimulation by vaccination, although they protected 3 of the 10 mice from toxin challenge. Other cytokines or other mechanisms of inducing antibody production might be involved in the protective immunity elicited by the Stx2eB subunit.

Stx1B and Stx2B administered i.n. were shown to be capable of promoting immunity that prevented Stx toxemia [27]. In the present study, however, Stx2eB-based constructs induced partial protection of mice against Stx2e challenge. To enhance the immunogenicity of Stx2eB-based antigens, appropriate mucosal adjuvant(s) might be required to be co-administered. Several studies have demonstrated that the B subunits of CT and LT are strong mucosal adjuvants [3, 8, 9, 17]. In addition, compared with the Stx2e protein alone, immunization with an LTB-linked Stx2eB was shown to induce a higher serum titer of Stx2eB-specific antibodies in rabbits and afforded better protection against Stx2e challenge in mice [22]. Incorporating LTB into the Stx2eB vaccination method would be of considerable interest, because an LTB-Stx2eB multivalent antigen could be a vaccine candidate not only for ED but also for diarrheal diseases caused by LT-producing *E. coli* in weaned piglets [18]. A further study to develop better Stx2eB-vaccine with greater efficiency is under way in our laboratory.

ACKNOWLEDGMENT. This work was supported by a grant from the development of fundamental technologies for production of high-value material using transgenic plants project managed by The Ministry of Economy, Trade and Industry of Japan.

REFERENCES

1. Austin, P. R., Jablonski, P. E., Bohach, G. A., Dunker, A. K. and Hovde, C. J. 1994. Evidence that the A₂ fragment of Shiga-like toxin type I is required for holotoxin integrity. *Infect. Immun.* **62**: 1768–1775. [Medline]

2. Cummings, M. D., Ling, H., Armstrong, G. D., Brunton, J. L. and Read, R. J. 1998. Modeling the carbohydrate-binding specificity of pig edema toxin. *Biochemistry* **37**: 1789–1799. [[Medline](#)] [[CrossRef](#)]
3. de Haan, L., Verweij, W., Agsteribbe, E. and Wikschut, J. 1998. The role of ADP-ribosylation and G_{M1}-binding activity in the mucosal immunogenicity and adjuvant activity of *Escherichia coli* heat-labile enterotoxin and *Vibrio cholera* toxin. *Immunol. Cell Biol.* **76**: 270–279. [[Medline](#)] [[CrossRef](#)]
4. Fraser, M. E., Fujinaga, M., Cherney, M. M., Melton-Celsa, A. R., Twiddy, E. M., O'Brien, A. D. and James, M. N. G. 2004. Structure of Shiga toxin type 2 (Stx2) from *Escherichia coli* O157:H7. *J. Biol. Chem.* **279**: 27511–27517. [[Medline](#)] [[CrossRef](#)]
5. Gordon, V. M., Whipp, S. C., Moon, H. W., O'Brien, A. D. and Samuel, J. E. 1992. An enzymatic mutant of Shiga-like toxin II variant is a vaccine candidate for edema disease of swine. *Infect. Immun.* **60**: 485–490. [[Medline](#)]
6. Gupta, P., Singh, M. K., Singh, Y., Gautam, V., Kumar, S., Kumar, O. and Dhaked, R. K. 2011. Recombinant Shiga toxin B subunit elicits protection against Shiga toxin via mixed Th type immune response in mice. *Vaccine* **29**: 8094–8100. [[Medline](#)] [[CrossRef](#)]
7. Holmgren, J., Svennerholm, A. M., Lönnroth, I., Fall-Persson, M., Markman, B. and Lundbeck, H. 1977. Development of improved cholera vaccine based on subunit toxoid. *Nature* **269**: 602–604. [[Medline](#)] [[CrossRef](#)]
8. Holmgren, J., Lycke, N. and Czerkinsky, C. 1993. Cholera toxin and cholera B subunit as oral-mucosal adjuvant and antigen vector systems. *Vaccine* **11**: 1179–1184. [[Medline](#)] [[CrossRef](#)]
9. Isaka, M., Zhao, Y., Nobusawa, E., Nakajima, S., Nakajima, K., Yasuda, Y., Matsui, H., Hasegawa, T., Maeyama, J., Morokuma, K., Ohkuma, K. and Tochikubo, K. 2008. Protective effect of nasal immunization of influenza virus hemagglutinin with recombinant cholera toxin B subunit as a mucosal adjuvant in mice. *Microbiol. Immunol.* **52**: 55–63. [[Medline](#)] [[CrossRef](#)]
10. Kundu, J., Mazumder, R., Srivastava, R. and Srivastava, B. S. 2009. Intranasal immunization with recombinant toxin-coregulated pilus and cholera toxin B subunit protects rabbits against *Vibrio cholerae* O1 challenge. *FEMS Immunol. Med. Microbiol.* **56**: 179–184. [[Medline](#)] [[CrossRef](#)]
11. Lencer, W. I. and Saslowsky, D. 2005. Raft trafficking of AB5 subunit bacterial toxins. *Biochim. Biophys. Acta* **1746**: 314–321. [[Medline](#)] [[CrossRef](#)]
12. MacLeod, D. L., Gyles, C. L. and Wilcock, B. P. 1991. Reproduction of edema disease of swine with purified Shiga-like toxin II variant. *Vet. Pathol.* **28**: 66–73. [[Medline](#)] [[CrossRef](#)]
13. Makino, S., Watarai, M., Tabuchi, H., Shirahata, T., Furuoka, H., Kobayashi, Y. and Takeda, Y. 2001. Genetically modified Shiga toxin 2e (Stx2e) producing *Escherichia coli* is a vaccine candidate for porcine edema disease. *Microb. Pathog.* **31**: 1–8. [[Medline](#)] [[CrossRef](#)]
14. Marcato, P., Griener, T. P., Mulvey, G. L. and Armstrong, G. D. 2005. Recombinant Shiga toxin B-subunit-keyhole limpet hemocyanin conjugate vaccine protects mice from Shigatoxemia. *Infect. Immun.* **73**: 6523–6529. [[Medline](#)] [[CrossRef](#)]
15. Marcato, P., Mulvey, G., Read, R. J., Helm, K. V., Nation, P. N. and Armstrong, G. D. 2001. Immunoprophylactic potential of cloned Shiga toxin 2 B subunit. *J. Infect. Dis.* **183**: 435–443. [[Medline](#)] [[CrossRef](#)]
16. Matsui, T., Asao, H., Ki, M., Sawada, K. and Kato, K. 2009. Transgenic lettuce producing a candidate protein for vaccine against edema disease. *Biosci. Biotechnol. Biochem.* **73**: 1628–1634. [[Medline](#)] [[CrossRef](#)]
17. Norton, E. B., Lawson, L. B., Freytag, L. C. and Clements, J. D. 2011. Characterization of a mutant *Escherichia coli* heat-labile toxin, LT(R192G/L211A), as a safe and effective oral adjuvant. *Clin. Vaccine Immunol.* **18**: 546–551. [[Medline](#)] [[CrossRef](#)]
18. Odumosu, O., Nicholas, D., Yano, H. and Langridge, W. 2010. AB toxins: a paradigm switch from deadly to desirable. *Toxins* **2**: 1612–1645. [[Medline](#)] [[CrossRef](#)]
19. Ohmura-Hoshino, M., Yamamoto, M., Yuki, Y., Takeda, Y. and Kiyono, H. 2004. Non-toxic Stx derivatives from *Escherichia coli* possess adjuvant activity for mucosal immunity. *Vaccine* **22**: 3751–3761. [[Medline](#)] [[CrossRef](#)]
20. Paton, A. W., Beutin, L. and Paton, J. C. 1995. Heterogeneity of the amino-acid sequences of *Escherichia coli* Shiga-like toxin type-I operons. *Gene* **153**: 71–74. [[Medline](#)] [[CrossRef](#)]
21. Pugh-Humphreys, R. G. P. and Thomson, A. W. 1998. Cytokines and their receptors as potential therapeutic targets. pp 885–951. *In: The Cytokine Handbook*, 3rd ed. (Thomson, A. W. ed.), Academic Press, London.
22. Ran, X. Q., Wang, H. Z., Liu, J. J., Li, S. and Wang, J. F. 2008. The immunogenicity of fusion protein linking the carboxyl terminal of B subunit of Shiga toxin 2 to the B subunit of *E. coli* heat-labile enterotoxin. *Vet. Microbiol.* **127**: 209–215. [[Medline](#)] [[CrossRef](#)]
23. Samuel, J. E., Perera, L. P., Ward, S., O'Brien, A. D., Ginsburg, V. and Krivan, H. C. 1990. Comparison of the glycolipid receptor specificities of Shiga-like toxin type II and Shiga-like toxin type II variants. *Infect. Immun.* **58**: 611–618. [[Medline](#)]
24. Smith, M. J., Melton-Celsa, A. R., Sinclair, J. F., Carvalho, H. M., Robinson, C. M. and O'Brien, A. D. 2009. Monoclonal antibody 11E10, which neutralizes Shiga type 2 (Stx2), recognizes three regions on the Stx2 A subunit, blocks the enzymatic action of the toxin *in vitro*, and alters the overall cellular distribution of the toxin. *Infect. Immun.* **77**: 2730–2740. [[Medline](#)] [[CrossRef](#)]
25. Takao, T., Tanabe, T., Hong, Y.M., Shimonishi, Y., Kurazono, H., Yutsudo, T., Sasakawa, C., Yoshikawa, M. and Takeda, Y. 1988. Identity of molecular structure of Shiga-like toxin I (VT1) from *Escherichia coli* O157:H7 with that of Shiga toxin. *Microb. Pathog.* **5**: 57–69. [[Medline](#)] [[CrossRef](#)]
26. Takeda, Y., Kurazono, H. and Yamasaki, S. 1993. Vero toxins (Shiga like-toxin) produced by enterohemorrhagic *Escherichia coli* (verocytotoxin-producing *E. coli*). *Microbiol. Immunol.* **37**: 591–599. [[Medline](#)]
27. Tsuji, T., Shimizu, T., Sasaki, K., Tsukamoto, K., Arimitsu, H., Ochi, S., Shimizu, T., Taniguchi, K., Noda, M., Neri, P. and Mori, H. 2008. A nasal vaccine comprising B-subunit derivative of Shiga toxin 2 for cross-protection against Shiga toxin types 1 and 2. *Vaccine* **26**: 2092–2099. [[Medline](#)] [[CrossRef](#)]
28. Wasteson, Y. 2001. Zoonotic *Escherichia coli*. *Acta Vet. Scand.* **95**: 79–84. [[Medline](#)]
29. Yutsudo, T., Nakabayashi, N., Hirayama, T. and Takeda, Y. 1987. Purification and some properties of a vero toxin from *Escherichia coli* O157:H7 that is immunologically unrelated to Shiga toxin. *Microb. Pathog.* **3**: 21–30. [[Medline](#)] [[CrossRef](#)]