



Contents lists available at ScienceDirect

Saudi Journal of Biological Sciences

journal homepage: www.sciencedirect.com

Original article

Genetic variability and phylogenetic analysis among strains of deformed wing virus infesting honey bees and other organisms

Hossam Abou-Shaara^a, Sara AlAshaal^b, Mohamed Nasser^{b,*}, Omaima Nasif^c, Sulaiman Alharbi^d^a Department of Plant Protection, Faculty of Agriculture, Damanhour University, Damanhour 22516, Egypt^b Department of Entomology, Faculty of Science, Ain Shams University, Cairo, Egypt^c Department of Physiology, College of Medicine, King Saud University [Medical City], King Khalid University Hospital, PO Box 2925, Riyadh, 11461, Saudi Arabia^d Department of Botany & Microbiology College of Science King, Saud University P.O Box 2455, Riyadh 11451, Saudi Arabia

ARTICLE INFO

Article history:

Received 16 November 2020

Revised 9 December 2020

Accepted 20 December 2020

Available online 28 December 2020

Keywords:

Viruses

Apiculture

Genetics

Primers

Bioinformatics

ABSTRACT

Various viruses can infect honey bees, but deformed wing virus (DWV) is considered the most dangerous virus to them and has role in the sudden decline of bee colonies. This virus has different strains; however, there are no available studies to compare the characteristics of these strains utilizing bioinformatics. In this study, 27 strains of deformed wing virus were analyzed based on their sequences and their genetic relationships. Also, some primers were designed and tested to identify their ability to separate DWV strains. The percentages range from 28.99% to 29.63%, 22.28% to 22.78%, 15.73% to 16.28%, and 31.71% to 32.86% for nucleotides A, G, C, and T, respectively in all strains. The numbers of polymorphic sites as well as nucleotide diversity were highly similar in all strains. Statistical analyses generally showed the absence of high variations between sequences. Also, the phylogenetic tree classified strains into three groups. The network between strains of each group was established and discussed based on their geographical locations. Two groups contained strains from USA and Europe while one group contained strains from Asia. Rapid variations and mutations in the sequences of DWV were suggested. Notably, genetic studies on DWV are lacking in some geographical regions. The variations between strains detected in honey bees and other organisms were discussed. Four primers were designed and tested beside two reference primers. One of the designed primers showed the best results in binding with all DWV strains except one.

© 2020 The Author(s). Published by Elsevier B.V. on behalf of King Saud University. This is an open access article under the CC BY-NC-ND license (<http://creativecommons.org/licenses/by-nc-nd/4.0/>).

1. Introduction

Intensive keeping of honeybee colonies (*Apis mellifera*) is being done worldwide to supply plants with effective pollinators and to provide the market with other bee products (Southwick and Southwick, 1992; Krell, 1996; Morse and Calderone, 2000; Aizen and Harder, 2009; Al-Ghamdi et al., 2016). Thus, the health of bee colonies is a worldwide concern. The intensive keeping of bee colonies as well as the trade of bee equipment and products caused the prevalence of various bee diseases from geographical

location to another (Matheson, 2000; Mutinelli, 2011; Schittny et al., 2020). One of these diseases is the infection of bee colonies with deformed wing virus (DWV; Iflavirus, Iflaviridae) which was detected firstly in Japan (Allen and Ball, 1996; Calderon et al., 2003; De Miranda and Genersch, 2010). This virus currently occurs in various countries outside Asia (Berényi et al., 2007). DWV has been considered among the reasons behind the global decline of bee colonies (vanEngelsdorp et al., 2009; Bacandritsos et al., 2010; Neumann and Carreck, 2010; Dainat et al., 2012; Brettell et al., 2017; Hristov et al., 2020), and winter loss of bee colonies (Highfield et al., 2009; Natsopoulou et al., 2017).

This virus can cause clear symptoms in the infected bees including the deformation and dwarfing of one or both wings beside reducing survival (Kovac and Craisheim, 1988; Dainat et al., 2012; Abou-Shaara, 2018). The symptoms are linked with the virus load in the infected bees (Chen et al., 2005; Tentcheva et al., 2006). Thus, bees can be infected with this virus without clear symptoms (Tentcheva et al., 2006; Brettell et al., 2017). In fact, the infection occurs in immature stages without preventing the development

* Corresponding author at: Department of Entomology, Faculty of Science, Ain Shams University, Cairo, Egypt.

E-mail address: mgnasser@sci.asu.edu.eg (M. Nasser).

Peer review under responsibility of King Saud University.



Production and hosting by Elsevier

into adult stages (Bailey and Ball, 1991). There are a close relationship between the infestation of bee colonies with *Varroa* mites and the prevalence of DWV in bee colonies (Bowen-Walker et al., 1999; Nordstrom, 2003; Gisder et al., 2009; Prisco et al., 2011). However, DWV has several routes to infect bees regardless of the presence of *Varroa* mites (Chen et al., 2004, 2005; Yue and Genersch, 2005; Highfield et al., 2009). Also, this virus has been detected in *Apis florea* and *Apis cerana* (Allen and Ball, 1996) and in other insects not belong to genus *Apis* including *Vespa* hornets (Forzan et al., 2017; Mazzei et al., 2018) and bumblebees (Genersch et al., 2006).

The particle of DWV is 30-nm icosahedral with positive single strand RNA and 3 structural proteins (Bailey and Ball, 1991). This virus overtime has been separated into various strains. These strains are separated geographically and have shown global distribution (Berényi et al., 2007). Such global occurrence can be attributed to the worldwide spread of *Varroa* mites (Berényi et al., 2007). Bee colonies from the same apiary can be infected with more than one strain of DWV (Jannikar-Ciglencecki et al., 2019). The sequences of some DWV strains are available online on different resources. This can help in utilizing bioinformatics to understand the relationships between these strains as well as exploring their genetic characteristics, in a similar way to previous investigations on bee virus and honey bees (Abou-Shaara, 2019a; Abou-Shaara et al., 2021). Moreover, it is possible to design and test various primers to separate strains of organisms effectively (Abou-Shaara and Elbanoby, 2020). Previous studies designed primers to identify DWV in bees or *Varroa* mites (Tentcheva et al., 2006), but there are no studies on primers that can discriminate between strains. Also, the availability of sequences allows the development of different statistical trends and software (Abou-Shaara and Bayoumi, 2019; Abou-Shaara, 2020). Indeed, the rapid development of genetic analysis tools encourages the assessment of genetic properties and relationships between organisms continually. In this study, a combination of several tools, software and statistical methods were used to explore sequences of DWV strains to better understand the genetic relationships between them as well as to develop primers to separate them. Moreover, the geographical distribution of these strains was explained based on the analysis of genetic networks.

2. Materials and methods

2.1. DWV strains

In this study 27 strains of deformed wing virus (DWV) from the NCBI (ncbi.nlm.nih.gov/) were used. The details of these strains including number of bases, accession numbers/ versions, and the

abbreviations as DWV+ number are presented in Table 1. These abbreviations were used to avoid the repetition of the full strain name. In these strains the uracil (U) bases were replaced by thymine (T) bases. All these strains were detected in honey bees, *Apis mellifera*, except DWV2 and DWV3 in *Apis cerana*, DWV15 and DWV16 in *Varroa* mites, DWV18 and DWV19 in dipteran insects, while DWV20 and DWV21 in *Vespa velutina*.

3. Sequence analysis

3.1. Sequence composition

The percentages of each nucleotide type: A, T, C, and G in the sequences of the studied DWV strains were calculated. This allows the comparisons between them based on base composition (Table 2).

3.2. General sequence divergence

The virus DWV1 to DWV13 (N = 13) was considered as a group while the virus DWV14 to DWV27 (N = 14) was considered as a second group. The divergences between the two groups in their sequences including polymorphic sites, nucleotide diversity and total number of mutations were identified using DnaSP software v 6 (Rozas et al. 2017).

3.3. Neutrality tests

The Tajima's (Tajima, 1989) and Fu and Li's (Fu and Li, 1993) tests were used to compare sequences of the studied DWV strains using DnaSP software v 6 (Rozas et al., 2017).

3.4. Statistical variations

The one way ANOV was used to test the significant differences between sequences (Abou-Shaara and Bayoumi, 2019; Abou-Shaara, 2020). Briefly, the nucleotides were changed into numbers as A = 1, G = 2, C = 3, and T = 4. Then, these numerical data arranged in Excel sheet and analyzed statistically (significance level of 0.05) using SPSS v.16 (2007, Chicago, USA).

3.5. Digestion

The sequences of the studied DWV strains were digested in silico by the enzymes available at the Genome Compiler 2.2.88 (genomecompiler.com) with ladder NEB 100 bp (Abou-Shaara, 2019b). This allows the comparisons between fragments of each strain.

Table 1

Information about the used 27 deformed wing virus strains in the study. An abbreviation as DWV followed by a number was given to each strain and is presented between parentheses.

Strains (abbreviation)	Accession/Version	Base nu.	Strains (abbreviation)	Accession/Version	Base nu.
DJE202 (DWV1)	KJ437447.1	10167	VDV-1-DWV-No-9 (DWV15)	HM067438.1	10154
DWV_SVN(DWV2)	MN607198.1	10113	VDV-1-DWV-No-5 (DWV16)	HM067437.1	10149
DWV_NVN(DWV3)	MN607197.1	10113	PA (DWV17)	AY292384.1	10166
VIVA-b2b (DWV4)	MN746311.1	10111	FTA2-7 (DWV18)	MT096529.1	10126
DWV_REC (DWV5)	MN538210.1	10145	FTA1-4 (DWV19)	MT096518.1	10107
DWV_B (DWV6)	MN538209.1	10111	DWV/159 M (DWV20)	MN565038.1	9434
DWV_A (DWV7)	MN538208.1	10099	DWV/144I (DWV21)	MN565037.1	10113
Maryland (DWV8)	MG831204.1	10188	DWV_MS (DWV22)	MH267696.1	10122
85-DWV (DWV9)	KX373899.2	10146	DWV_MR (DWV23)	MH267695.1	10152
DWV (DWV10)	NC_004830.2	10140	Liaoning-1 (DWV24)	MF770715.1	10167
2C1 (DWV11)	MF036686.1	9838	AmE711 (DWV25)	KT004425.1	10137
leuven-dwv1 (DWV12)	KX783225.1	10112	Korea-2(DWV26)	JX878305.1	10114
Austria 1414 (DWV13)	KU847397.1	10203	Korea-1 (DWV27)	JX878304.1	10111
Chilensis A1 (DWV14)	JQ413340.1	10171			

Table 2
Base composition of 27 DWV strains.

Strain	A%	G%	C%	T%
DJE202 (DWV1)	29.34	22.55	16.22	32.86
DWV_SVN (DWV2)	29.12	22.78	16.28	31.81
DWV_NVN (DWV3)	29.12	22.78	16.28	31.81
VIVA-b2b (DWV4)	29.43	22.40	16.13	32.03
DWV_REC (DWV5)	29.17	22.63	16.11	32.07
DWV_B (DWV6)	29.28	22.52	15.95	32.24
DWV_A (DWV7)	29.41	22.44	15.99	32.14
Maryland (DWV8)	29.42	22.51	15.90	32.15
85-DWV (DWV9)	29.41	22.43	16.07	32.07
DWV (DWV10)	29.26	22.31	15.73	32.00
2C1 (DWV11)	29.27	22.63	15.78	32.30
leuven-dwv1 (DWV12)	29.23	22.60	15.97	32.18
Austria 1414 (DWV13)	29.63	22.30	16.03	32.01
Chilensis A1 (DWV14)	29.63	22.31	15.96	32.03
VDV-1-DWV-No-9 (DWV15)	29.51	22.51	16.12	31.84
VDV-1-DWV-No-5 (DWV16)	29.29	22.69	16.01	32.00
PA (DWV17)	29.55	22.38	16.00	32.04
FTA2-7 (DWV18)	29.41	22.43	16.11	32.04
FTA1-4 (DWV19)	29.41	22.45	16.06	32.05
DWV/159M (DWV20)	28.99	22.70	16.17	32.00
DWV/144I (DWV21)	29.22	22.57	15.98	32.20
DWV_MS (DWV22)	29.40	22.36	16.12	32.10
DWV_MR (DWV23)	29.46	22.38	16.02	32.12
Liaoning-1 (DWV24)	29.34	22.70	15.85	32.08
AmE711 (DWV25)	29.48	22.28	16.11	32.01
Korea-2 (DWV26)	29.34	22.73	16.20	31.71
Korea-1 (DWV27)	29.12	22.78	16.21	31.86

4. Genetic relationships

4.1. The phylogenetic relationships

The sequences of these DWV strains were aligned using MUSCLE (Edgar, 2004) then the phylogenetic tree was constructed using the statistical method of neighbor-joining. This analysis was done using MEGA6 (Tamura et al., 2013). Sacbrood virus as an out-group was used during the analysis.

4.2. Networks between DWV strains

The Population Analysis with Reticulate Trees (PopART, Leigh and Bryant, 2015) was used to estimate gene genealogies using TCS networks (Clement et al., 2002) between groups (clusters) of DWV strains resulted from the phylogenetic relationships. Also, some statistical values were calculated including nucleotide diversity, number of segregation sites, and number of parsimony-informative sites.

4.3. Divergence between groups

The groups resulted from the phylogenetic tree were exposed to divergence analysis to calculate polymorphic sites, nucleotide diversity and total number of mutations in the whole groups using DnaSP software v 6 (Rozas et al. 2017).

5. Primer sets

Four primer sets to discriminate between DWV strains were designed with the option of auto primer design by Genome Compiler 2.2.88. These primers were compared with two primer sets as references. The reference primers were used by Gaetana et al. (2006). The ability of these primers to bind and amplify specific regions in sequences of DWV strains were studied using SnapGene 4.2.6 (snapgene.com). The presence of binding sites in the DWV strains was compared and the perfect primers to identify and discriminate between them were identified.

6. Results and discussion

6.1. Sequence analysis

6.1.1. Sequence composition

The percentages of nucleotides A ranged from 28.99% (DWV20) to 29.63% (DWV13 and DWV14) while nucleotides G ranged from 22.28% (DWV25) to 22.78% (DWV2, DWV3, and DWV27). The lowest percentage of nucleotides C was 15.73% (DWV10) while the highest value was 16.28% (DWV2 and DWV3). The percentages of nucleotides T ranged from 31.71% (DWV26) to 32.86% (DWV1). Nucleotides T had the highest percentages followed by A, then G and finally C in all strains. Also, the variations between the highest and the lowest values of each nucleotide type were 0.64, 0.5, 0.55, and 1.15% for A, G, C, and T, respectively. The identical percentages in all nucleotide types were found in DWV2 and DWV3. Generally, some similarities in base composition between all DWV strains are shown based on percentages. These similarities are supported by a previous study indicated the presence of a single monophyletic cluster for some genotypes of DWV (Berényi et al., 2007). However, the variations between strains in their nucleotide percentages can be used to divide them into related groups.

6.2. General sequence divergence.

The strains were divided into groups then some parameters were compared (Table 3). The number of polymorphic sites was highly similar between the two groups. The second group had higher total number of mutations and nucleotide diversity than the first one. However, the shared mutations between the two groups were 22665, representing 94.19% and 86.16% of the total number of mutations for group 1 and 2, respectively. Also, nucleotide diversity as a measure to the polymorphism degree within a given group (population) showed the same pattern with some variations in the two groups apart from the differences in the number of strains per each group (Fig. 1). Similarly, DWV from Carniolan honey bees in Slovenia showed high degree of genetic diversity

Table 3
Sequence divergence of the studied DWV strains considering DWV1 to DWV13 as the first group while DWV14 to DWV27 as the second group.

Parameters	The first group	The second group
Number of sequences	13	14
Number of polymorphic sites	9432	9433
Total number of mutations	24,062	26,305
Average number of nucleotide differences	k: 6358.474	k: 6669.626
Nucleotide diversity	Pi(1): 0.674000	Pi(1): 0.70698
Shared mutations	22,665	

(Jamnikar-Ciglenecki et al., 2019). Indeed, these results are in line with the aforementioned results of nucleotide percentages.

6.3. Neutrality tests.

Significant variation was found between sequences of DWV strains based on Fu and Li's D* test only while not significant variations were found between sequences based on Tajima's D and Fu and Li's F* tests (Table 4). This result showed the possibility of diving strains into close groups due to the presence of variations in their sequences.

6.4. Statistical variations

The statistical variations between the nucleotides of the full sequences, nucleotide A, T, C, and G showed the absence of statistical variations (P > 0.05). This suggests the same origin of all DWV strains regardless of their geographical location or host.

6.5. Digestion

Fig. 2 shows results of the enzymatic digestion in silico. The total number of fragments ranged from 13 (DWV11) to 22 (DWV5 and DWV6). In all strains, fragments less than 300 bp

Table 4
The neutrality tests of 27 DWV sequences.

Parameters	Tajima's test	Fu and Li's
Tajima's D	-0.38408, P > 0.10	-
Fu and Li's D*	-	1.50047, P less than 0.05
Fu and Li's F*	-	1.03849, P > 0.10

had the highest number followed by fragments between 300 and 600 bp, then between 600 and 900 bp, and finally more than 900 bp. This indicates the similarities between the DWV strains; however, the number of fragments per each category showed variations between strains. Notably, the sequence of DWV contains only one large open reading frame encoding a 328-kDa polyprotein (Gaetana et al., 2006). This supports the similarities indicated from the enzymatic digestion.

7. Genetic relationships

7.1. Phylogenetic relationships

The phylogenetic tree (Fig. 3) clearly shows the presence of two major groups (A and B), and group A contained two main groups (A1 and A2). The first group contained 19 strains while the second group contained 8 strains. The classification of strains into close groups suggested their divergence than the common ancestor. The highly related strains were: DWV6 and DWV21 (from Netherlands and France), DWV11 and DWV24 (both from China), DWV2 and DWV3 (both from Vietnam), DWV26 and DWV27 (both from South Korea), DWV4 and DWV22 (both from Sweden), DWV17 and DWV25 (both from the USA), DWV18 and DWV19 (both from Spain). Three strains were placed away from other strains: DWV9 (France) and DWV13 (Austria) in group A, and DWV1 (Scotland) in group B. The out group was placed away from the DWV strains, confirming the accurateness of the tree. The phylogenetic relationships in relation to the geographical location between strains in groups A1, A2, and B are discussed by exploring the network between them as shown later.

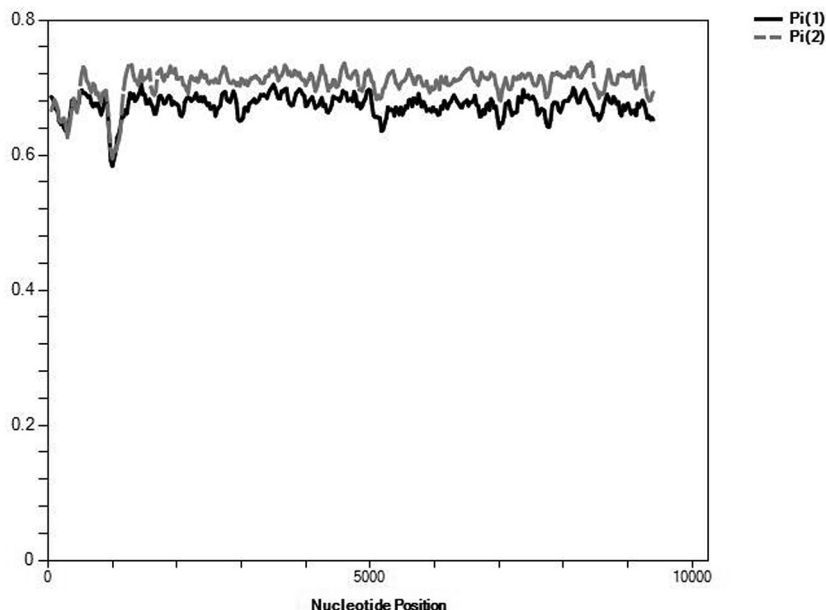

Fig. 1. Nucleotide diversity in the two groups. Pi (1) for first group (DWV1 to DWV13) and Pi (2) for the second group (DWV14 to DWV27). The Pi indicates the average number of nucleotide variations per site between sequences of two groups.

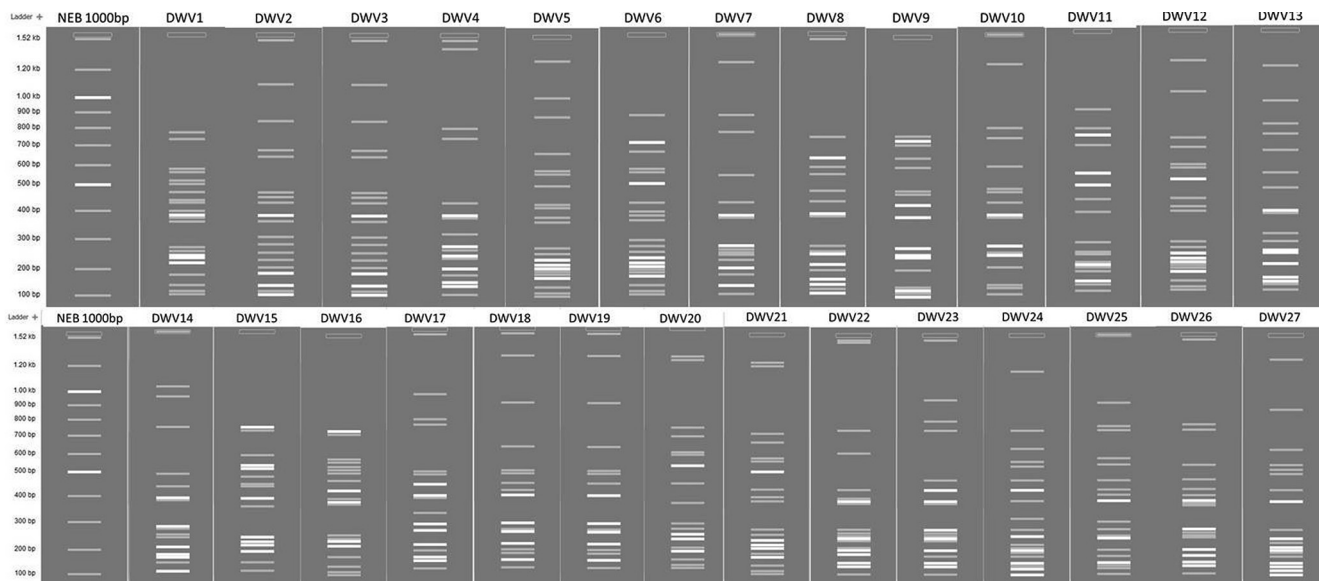

Fig. 2. The fragments of DWV strains using enzymes available at Genome Compiler.

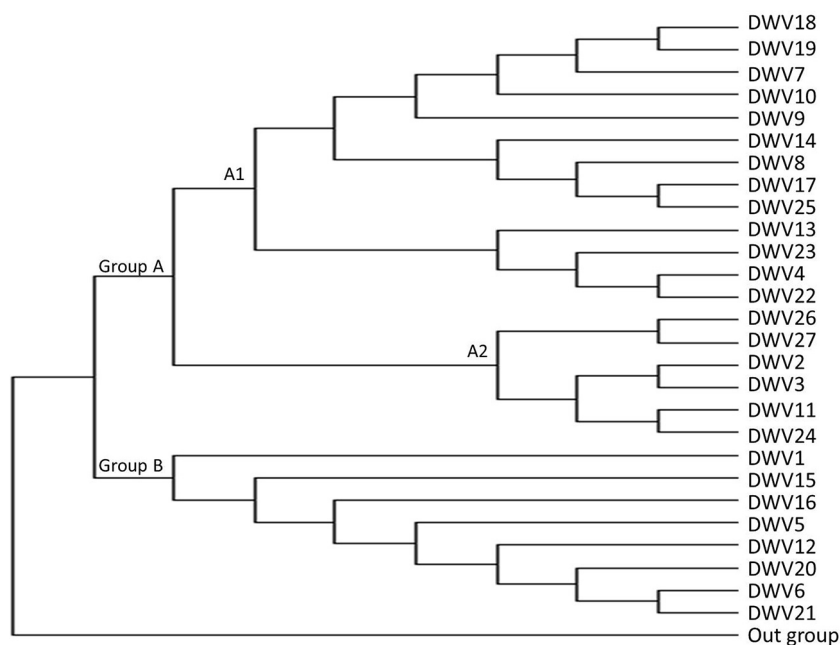

Fig. 3. Phylogenetic relationships between DWV strains.

7.2. Networks between DWV strains

DWV strains in group A1 from the phylogenetic tree contained strains from Europe, USA, Chile and New Zealand (Fig. 4). The network placed strains from Sweden and Austria close to each other as well as those from Italy and France. Also, two strains of DWV from Spain recorded in non-*Apis* species were placed together and away from the other strains. Strains from USA, Chile and New Zealand showed scattered manner in the network. The high number of mutations in the network showed the rapid changes in DWV sequences within and between geographical locations. For example, the ancestor of DWV4 and DWV22 had only 2 mutations then 34 mutations to form DWV22 and 63 mutations to form DWV4 and both strains from Sweden. A study by Brettell et al. (2017) showed greater variations in DWV genomes between geographical loca-

tions than phenotypes (i.e DWV form asymptomatic and symptomatic bee samples).

The strains of group A2 occurred in Asia (Fig. 5). The two strains from Vietnam were grouped together and away from the other strains. Indeed, these strains were recorded in *Apis cerana* and not *Apis mellifera*. High number of mutations (586) recorded in the ancestors of these strains. The network placed strains of South Korea together and those from China close to each other. However, high variations and mutations observed in this strains although their presence in Asia and in close geographical locations.

The group B of DWV stains occurred in Europe (Fig. 6). Strains of UK and Scotland were close to each other than those from other European countries. This can be explained by the partial isolation of UK and Scotland geographically than other European countries. Two strains from France (DWV20 and DWV21) were detected in

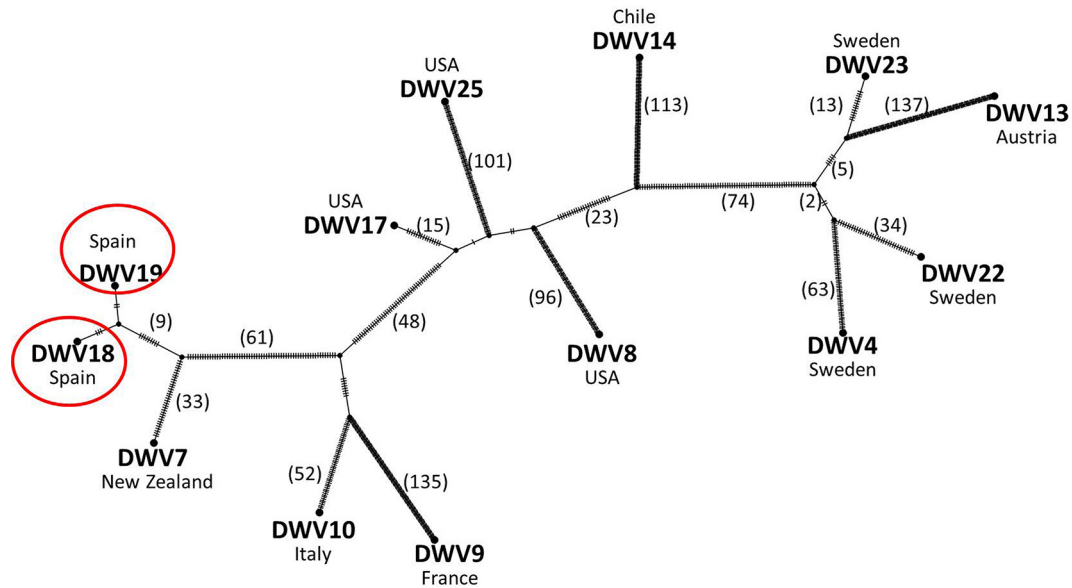

Fig. 4. The network between DWV strains of group A1. The strains DWV18 and 19 were detected in insects not belong to *Apis* spp. and marked with circle. The numbers of mutations are presented between parentheses.

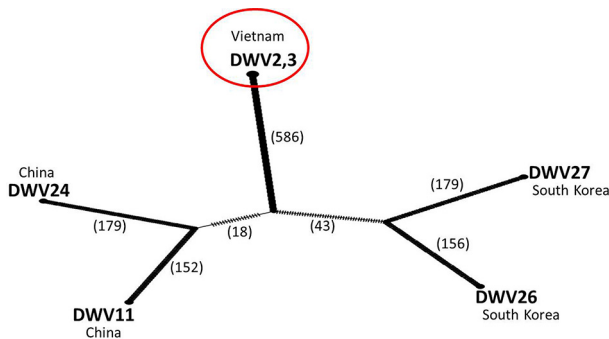

Fig. 5. The network between DWV strains of group A2. The strains DWV2 and DWV 3 were detected in *Apis cerana* and marked with circle. The numbers of mutations are presented between parentheses.

Vespa hornets and were placed close to each other. These strains had few mutations than the closet strains from Belgium and Netherlands (from 3 to 39 mutations). In fact, these hornets have invaded France recently (Leza et al., 2018) and DWV were able to adapt with this new host and infect them. This indicates the rapid distribution of this virus to infect many hosts; especially those overlapped with the geographical locations of honey bees. DWV type A can be transmitted by *Varroa* mites but without a propagative manner (Posada-Florez et al., 2019). In a similar way, the network showed that DWV6 (type A from Netherlands) was placed in the same group with DWV15 and DWV16 of UK isolated from *Varroa* mites. Similarly, the DWV strains from Carniolan honey bees and from *Varroa* mites showed close genetic relationships (Jamnikar-Ciglenecki et al., 2019).

As shown from Table 5, the highest nucleotide diversity was recorded in group A2 (from Asia) followed by group B (Europe), and then group A1 (Europe, USA, New Zealand and Chile). The number of sites that differed among sequences (Segregating sites)

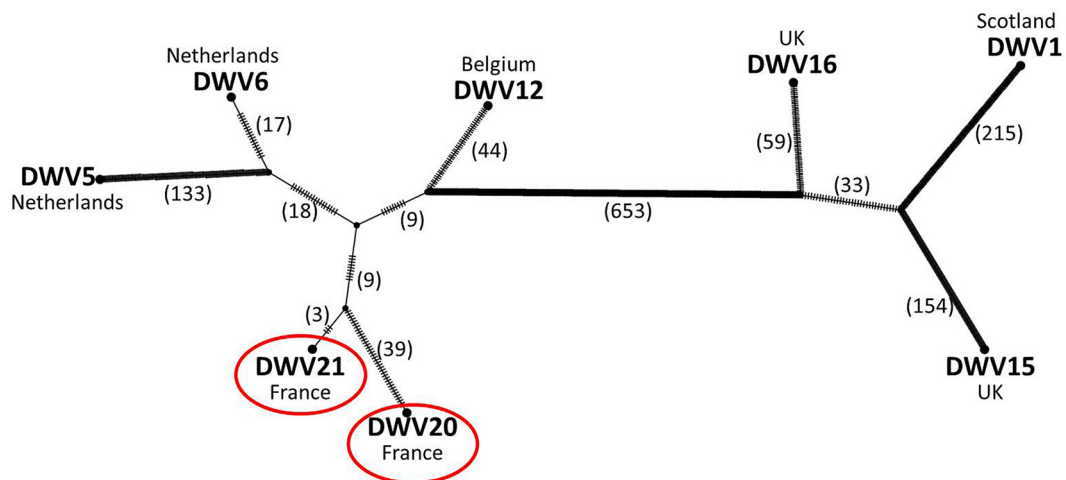

Fig. 6. The network between DWV strains of group B. The strains DWV20 and DWV21 were detected in insects not belong to *Apis* spp. and marked with circle. The numbers of mutations are presented between parentheses.

and the number of parsimony-informative sites were also high in group A2, followed by group B and then group A1. This can be explained by the presence of DWV from *Apis cerana* and *Apis mellifera* in Asia with rapid changes in sequences and adaptation unlike European countries where *Apis mellifera* as the main host.

The investigations on DWV showed evidence of recombination and positive selection (Dalmon et al., 2017). The reported variations in genetic characteristics of DWV strains and their clear divergence than their ancestors based on network analysis suggested the variations in their virulence. Accordingly, the results obtained by Barroso-Arévalo et al. (2019) suggested an effect of nucleotide variations in the sequences on the virulence of DWV. Although the occurrence of this virus in various countries such as North Africa including Egypt (Abd-El-Samie et al., 2017; Abou-Shaara, 2018), the Middle East (Haddad et al., 2017), and some Asian countries including India (mentioned in Desai et al., 2012), no sequences from such countries are available. Thus, studies in these regions are still required to better understand the global divergence of DWV than its ancestor.

7.3. Divergence between groups

The divergence parameters between the groups considering only DWV strains isolated from *Apis mellifera* or *Varroa* mites are presented in Tables 6 to Table 8. It is clear that group A1 is closer to group B with low number of fixed differences and high number of polymorphic sites as well as number of shared mutations (Table 7) than group A2 (Table 6). This can be explained by the occurrence of group A1 and B mostly in European countries. The group A2 which occurred in Asian countries was close to group A1 (Table 6) than group B (Table 8). The group A1 contained DWV from USA and New Zealand beside countries in South and Central Europe while group B contained countries only in North-west Europe. Thus, group A1 is geographically close to Asian countries than group B. Also, the trade between Asia and European countries in group A1 can explain the closet genetic relationships than group B. In fact, the phylogenetic tree placed group A1 and A2 in one group which is strongly supported by the divergence analysis between groups.

8. Primer sets

The designed primers and tested in this study are presented in Table 9. Also, two reference primers (Gaetana et al., 2006) were included in this investigation. Primer 4 showed the best results in binding with all DWV strains except DWV11, followed by primer 1 and then reference 2. Thus, these primers are perfect for the identification of DWV in infected bees or other organisms. Using these six primers except primer 2 can help in identifying the strain of DWV; especially, each primer showed binding sites with specific strains (Table 10.).

Table 5
Some statistical parameters between DWV strains of three groups (A1, A2, and B).

Parameters	Groups		
	A1	A2	B
Nucleotide diversity	n = 0.019099	n = 0.682591	n = 0.0547622
Number of segregation sites	765	9774	1131
Number of parsimony-informative sites	299	6927	895

Table 6
Sequence divergence of between group A1 and group A2, considering sequences recorded only in *Apis mellifera* or *Varroa* mites.

Parameters	Group A1	Group A2
Number of sequences	11	4
Number of polymorphic sites	9837	9619
Total number of mutations	25,612	16,503
Average number of nucleotide differences	k: 6819.291	k: 7214.667
Nucleotide diversity	Pi(1): 0.69316	Pi(1): 0.73335
Number of fixed differences	14	
Mutation polymorphic in group A1 only	2:11306	
Mutation polymorphic in group A2 only	1:2197	
Shared mutations	14,306	

Table 7
Sequence divergence of between group A1 and group B, considering sequences recorded only in *Apis mellifera* or *Varroa* mites.

Parameters	Group A1	Group B
Number of sequences	11	6
Number of polymorphic sites	10,098	10,024
Total number of mutations	26,290	20,185
Average number of nucleotide differences	k: 6997.818	K:6943.000
Nucleotide diversity	Pi(1): 0.69292	Pi(1): 0.68749
Number of fixed differences	0	
Mutation polymorphic in group A1 only	2:7864	
Mutation polymorphic in group B only	1:1759	
Shared mutations	18,426	

Table 8
Sequence divergence of between group A2 and group B, considering sequences recorded only in *Apis mellifera* or *Varroa* mites.

Parameters	Group A2	Group B
Number of sequences	4	6
Number of polymorphic sites	9619	9764
Total number of mutations	16,503	19,666
Average number of nucleotide differences	k: 7214.667	K:6762.267
Nucleotide diversity	Pi(1): 0.73335	Pi(1): 0.68736
Number of fixed differences	137	
Mutation polymorphic in group A1 only	2:8957	
Mutation polymorphic in group B only	1:5794	
Shared mutations	10,709	

Table 9
Sequences of primer sets designed in this study and the reference primers.

Primers	Sequences
1	TAAAGACTCAGCTCCATAGT TAGGACGCATTACCACTAGTTGA
2	ATATTTATTAGTTTTAATTTTT ATATAGGTTCACTCCTTTTAGT
3	TTACTCGCGTATTATCAACTAGT TTTTTTTTTTTTTTTTTTTTTTTT
4	GGTTGAGTTGCCCTCTAAAGACTC GTTATGCGACAATACGCGAGT
Reference 1	GGATGTTATCTCTTGGCTGGA CGATAATAATTTGCAACGCTGA
Reference 2	TGATTTTCAGCCTGTTTTGTG CCTCGTCTCTCTTCACTC

9. Conclusion

In the present study different techniques were employed to shade more lights on the sequences and genetic relationships between DWV strains. The similarities and dissimilarities in sequences of 27 strains were presented based on sequence composition and divergence, and statistical analyses. There were similarities in the abundance of nucleotide types based on nucleotide

Table 10
The binding sites with tested primers in the DWV sequences.

Strain	Primers				Reference 1	Reference 2
	1	2	3	4		
DWV1	✓	X	✓	✓	✓	✓
DWV2	✓	-	-	✓	✓	✓
DWV3	✓	-	-	✓	✓	-
DWV4	✓	X	X	✓	✓	✓
DWV5	-	X	X	✓	X	X
DWV6	-	X	X	✓	X	X
DWV7	✓	X	-	✓	✓	✓
DWV8	✓	X	✓	✓	-	✓
DWV9	✓	X	-	✓	-	✓
DWV10	✓	X	-	✓	-	✓
DWV11	X	-	X	X	-	✓
DWV12	-	X	X	✓	X	X
DWV13	✓	X	✓	✓	✓	✓
DWV14	✓	X	✓	✓	✓	✓
DWV15	✓	-	✓	✓	✓	✓
DWV16	✓	-	✓	✓	✓	-
DWV17	✓	X	✓	✓	✓	✓
DWV18	✓	X	-	✓	✓	✓
DWV19	✓	X	-	✓	✓	✓
DWV20	-	X	X	✓	X	X
DWV21	-	X	X	✓	X	X
DWV22	✓	X	-	✓	✓	✓
DWV23	✓	X	-	✓	✓	✓
DWV24	X	-	✓	✓	X	✓
DWV25	✓	X	-	✓	✓	✓
DWV26	✓	-	-	✓	-	✓
DWV27	✓	-	-	✓	-	-

X: no binding sites, -: one binding site with forward or reverse primer, ✓: two binding sites.

percentages. Also, the numbers of polymorphic sites as well as nucleotide diversity were highly similar in all DWV strains. The statistical analyses confirmed the partial similarities between all strains. On the other side, the variations between strains in their sequences showed the possibility of classifying them into related groups. The phylogenetic tree classified strains into three groups. The first group (A1) contained strains from Europe, USA, New Zealand and Chile, the second group (A2) contained strains from China and South Korea, and the third group (B) contained strains from Northwest Europe. The close genetic relationships between group A1 and A2 were confirmed by genetic network analysis. The study suggested that DWV was introduced from Asia to countries of group A1 while it was accidentally introduced to countries of group B. The sequence of DWV is not available from some regions including some African and Asian countries beside South America. Studies in these countries for the detection and sequencing DWV are recommended to better understand of the global distribution of this virus. In this study also specific primers were designed to identify DWV strains, and were tested beside reference primers. One primer (primer 4) showed the ability to bind with all DWV strains except DWV11. This primer is recommended for the identification of DWV in any samples. More investigations on the variations in the ability of DWV strains to infect honey bees/ *Varroa* mites and to cause damages to bee colonies are required.

Funding

This research was funded by Researchers Supporting Project, King Saud University number (RSP-2020/257), Riyadh, Saudi Arabia.

Declaration of Competing Interest

The authors declare that they have no known competing financial interests or personal relationships that could have appeared to influence the work reported in this paper.

Acknowledgments

This work is supported by Researchers Supporting Project, King Saud University number (RSP-2020/257), Riyadh, Saudi Arabia, so all authors appreciate king Saud University help.

References

Abd-El-Samie, E.M., Adham, F.K., El-Mohandes, S., Seyam, H., 2017. First detection of deformed wing and kakugo viruses in honeybees (*Apis mellifera* L.) in Egypt by real time-polymerase chain reaction (RT-PCR). *Afr. J. Biotechnol.* 16, 738–748.

Abou-Shaara, H.F., 2019a. Utilizing bioinformatics to detect genetic similarities between African honey bee subspecies. *J. Genet.* 98, 96. <https://doi.org/10.1007/s12041-019-1145-7>.

Abou-Shaara, H.F., 2019b. Highlights on the genetic relationships between some honey bee viruses using various techniques. *J. Appl. Biotechnol. Rep.* 6, 15–19.

Abou-Shaara, H.F., Bayoumi, S.R., 2019. Using mitochondrial DNA similarity percentages to analyze the maternal source of hybrid bees from two honey bee subspecies. *Sci. Pap. Anim. Sci. Biotechnol.* 52, 32–40.

Abou-Shaara, H.F., 2018. Calendar for the prevalence of honey bee diseases, with studying the role of some materials to control *Nosema*. *Kor. J. Appl. Entomol.* 57, 87–95.

Abou-Shaara, H.F., 2020. Using simple statistics to compare genetic sequences. *Thail. Statist.* 18, 373–380.

Abou-Shaara, H.F., Elbanoby, M.I., 2020. A bioinformatics study to detect the genetic characteristics of *Vespa* hornets (Hymenoptera: Vespidae). *J. Entomol. Res. Soc.* 22.

Abou-Shaara, H.F., Abbas, A.S., AL-Kahtani, S.N., Taha, E.K.A., Khan, K.A., Jamal, Z.A., Alotaibi, M.A., Ahmad, B., Khan, N.A., Qamer, S. and Anjum, S.I. 2020 Exploring the non-coding regions in the mtDNA of some honey bee species and subspecies. *Saudi J. Biol. Sci.* 28, 204–209. <https://doi.org/10.1016/j.sjbs.2020.09.047>.

Aizen, M.A., Harder, L.D., 2009. The global stock of domesticated honey bees is growing slower than agricultural demand for pollination. *Curr. Biol.* 19, 915–918.

Al-Ghamdi, A.A., Alsharhi, M.M., Abou-Shaara, H.F., 2016. Current status of beekeeping in the Arabian countries and urgent needs for its development inferred from a socio-economic analysis. *Asian J. Agri. Res* 10, 87–98.

Allen, M.F., Ball, B.V., 1996. The incidence and world distribution of honeybee viruses. *Bee World* 77, 141–162.

Bacandritsos, N., Granato, A., Budge, G., Papanastasiou, I., Roinioti, E., Caldon, M., Falcaro, C., Gallina, A., Mutinelli, F., 2010. Sudden deaths and colony population decline in Greek honey bee colonies. *J. Invert. Pathol.* 105, 335–340.

Bailey, L., Ball, B.V., 1991. *Honey bee pathology*. Academic Press, London, England.

Barroso-Arévalo, S., Vicente-Rubiano, M., Molero, F., Puerta, F., Sánchez-Vizcaino, J. M., 2019. Nucleotide sequence variations may be associated with virulence of deformed wing virus. *Apidologie* 50, 482–496.

- Berényi, O., Bakonyi, T., Derakhshifar, I., Köglberger, H., Topolska, G., Ritter, W., Pechhacker, H., Nowotny, N., 2007. Phylogenetic analysis of deformed wing virus genotypes from diverse geographic origins indicates recent global distribution of the virus. *Appl. Environ. Microbiol.* 73, 3605–3611.
- Bowen-Walker, P.L., Martin, S.J., Gunn, A., 1999. The transmission of Deformed Wing Virus between honeybees (*Apis mellifera* L.) by ectoparasitic mite *Varroa jacobsoni* Oud. *J. Invertebr. Pathol.* 73, 101–106.
- Brettell, L.E., Mordecai, G.J., Schroeder, D.C., Jones, I.M., Da Silva, J.R., Vicente-Rubiano, M., Martin, S.J., 2017. A comparison of deformed wing virus in deformed and asymptomatic honey bees. *Insects* 8, 28. <https://doi.org/10.3390/insects8010028>.
- Calderon, R.A., van Veen, J., Arce, H.G., Esquivel, M.E., 2003. Presence of deformed wing virus and Kashmir bee virus in Africanized honey bee colonies in Costa Rica infested with *Varroa destructor*. *Bee World* 84, 112–116.
- Chen, Y., Smith, I.B., Collins, A.M., Pettis, J.S., Feldlaufer, M.F., 2004. Detection of deformed wing virus infection in honey bees, *Apis mellifera* L., in the United States. *Am. Bee J.* 144, 557–559.
- Chen, Y.P., Higgins, J.A., Feldlaufer, M.F., 2005. Quantitative real-time reverse transcription-PCR analysis of deformed wing virus infection in the honeybee (*Apis mellifera* L.). *Appl. Environ. Microbiol.* 71, 436–441.
- Clement, M., Snell, Q., Walke, P., Posada, D., Crandall, K., 2002. TCS: estimating gene genealogies. *Proc 16th Int Parallel Distrib Process Symp* 2, 184.
- Dainat, B., Evans, J.D., Chen, Y.P., Gauthier, L., Neumann, P., 2012. Dead or alive: deformed wing virus and *Varroa destructor* reduce the life span of winter honeybees. *Appl. Environ. Microbiol.* 78, 981–987.
- Dalmon, A., Desbiez, C., Coulon, M., Thomasson, M., Le Conte, Y., Alaux, C., Vallon, J., Moury, B., 2017. Evidence for positive selection and recombination hotspots in Deformed wing virus (DWV). *Sci. Rep.* 7, 1–12.
- De Miranda, J.R., Genersch, E., 2010. Deformed wing virus. *J. Invert Pathol.* 103, S48–S61.
- Desai, S.D., Eu, Y.J., Whyard, S., Currie, R.W., 2012. Reduction in deformed wing virus infection in larval and adult honey bees (*Apis mellifera* L.) by double-stranded RNA ingestion. *Insect Mol. Biol.* 21, 446–455.
- Edgar, R.C., 2004. MUSCLE: multiple sequence alignment with high accuracy and high throughput. *Nucleic Acids Res.* 32, 1792–1797.
- Forzan, M., Sagona, S., Mazzei, M., Felicioli, A., 2017. Detection of deformed wing virus in *Vespa crabro*. *Bull. Insectol.* 70, 261–265.
- Fu, Y.-X., Li, W.-H., 1993. Statistical tests of neutrality of mutations. *Genetics* 133, 693–709.
- Gaetana, L., Miranda, J.R., Boniotti, M.B., Cameron, C.E., Lavazza, A., Capucci, L., Camazine, S.M., Rossi, C., 2006. Molecular and biological characterization of deformed wing virus of honeybees (*Apis mellifera* L.). *J. Virol.* 80, 4998–5009.
- Genersch, E., Yue, C., Fries, I., de Miranda, J.R., 2006. Detection of deformed wing virus (DWV), a honey bee viral pathogen, in bumble bees (*Bombus terrestris* and *Bombus pascuorum*) with wing deformities. *J. Invertebr. Pathol.* 91, 61–63.
- Gisder, S., Aumeier, P., Genersch, E., 2009. Deformed wing virus: replication and viral load in mites (*Varroa destructor*). *J. Gen. Virol.* 90, 463–467.
- Haddad, N.J., Nouredine, A., Al-Shagour, B., Loucif-Ayad, W., El-Niweiri, M.A., Anaswah, E., Almaleky, A.S., 2017. Distribution and variability of deformed wing virus of honeybees (*Apis mellifera*) in the Middle East and North Africa. *Insect sci* 24 (1), 103–113.
- Highfield, A.C., El Nagar, A., Mackinder, L.C., Laure, M.L.N., Hall, M.J., Martin, S.J., Schroeder, D.C., 2009. Deformed wing virus implicated in overwintering honeybee colony losses. *Appl. Environ. Microbiol.* 75, 7212–7220.
- Hristov, P., Shumkova, R., Palova, N., Neov, B., 2020. Factors associated with honey bee colony losses: a mini-review. *Vet. Sci.* 7, 166. <https://doi.org/10.3390/vetsci7040166>.
- Jamnikar-Ciglenecki, U., Pislak, O., Očepk, M., Toplak, I., 2019. Genetic diversity of deformed wing virus from *Apis mellifera carnica* (Hymenoptera: Apidae) and *Varroa* mite (Mesostigmata: Varroidae). *J. Econ. Entomol.* 112, 11–19.
- Kovac, H., Crailsheim, K., 1988. Lifespan of *Apis mellifera Carnica* Pollm. infested by *Varroa jacobsoni* in relation to season and extent of infestation. *J. Apic. Res.* 27, 230–238.
- Krell R. 1996 Value-added products from beekeeping (No. 124). Food & Agriculture Org.
- Leigh, J.W., Bryant, D., 2015. PopART: Full-feature software for haplotype network construction. *Meth. Ecol. Evol.* 6, 1110–1116.
- Leza, M., Miranda, M.Á., Colomar, V., 2018. First detection of *Vespa velutina nigrithorax* (Hymenoptera: Vespidae) in the Balearic Islands (Western Mediterranean): a challenging study case. *Biol. Inv.* 20, 1643–1649.
- Matheson, A., 2000. Managing risks in world trade in bees and bee products. *Apiacta* 35, 1–12.
- Mazzei, M., Forzan, M., Cili, G., Sagona, S., Bortolotti, L., Felicioli, A., 2018. First detection of replicative deformed wing virus (DWV) in *Vespa velutina nigrithorax*. *Bull. Insectol.* 71, 211–216.
- Morse, R.A., Calderone, N.W., 2000. The value of honey bees as pollinators of U.S. crops in 2000. *Bee Cul.* 128, 2–15.
- Mutinelli, F., 2011. The spread of pathogens through trade in honey bees and their products (including queen bees and semen): overview and recent developments. *Rev. Sci. Tech.* 30, 257.
- Natsopoulou, M.E., McMahon, D.P., Doublet, V., Frey, E., Rosenkranz, P., Paxton, R.J., 2017. The virulent, emerging genotype B of Deformed wing virus is closely linked to overwinter honeybee worker loss. *Sci. Rep.* 7, 1–9.
- Neumann, P., Carreck, N.L., 2010. Honey bee colony losses. *J. Apic. Res.* 49, 1–6.
- Nordstrom, S., 2003. Distribution of deformed wing virus within honey bee (*Apis mellifera*) brood cells infested with the ectoparasitic mite *Varroa destructor*. *Exp. Appl. Acarol.* 29, 293–302.
- Posada-Florez, F., Childers, A.K., Heerman, M.C., Egekwu, N.I., Cook, S.C., Chen, Y., Evans, J.D., Ryabov, E.V., 2019. Deformed wing virus type A, a major honey bee pathogen, is vectored by the mite *Varroa destructor* in a non-propagative manner. *Sci. Rep.* 9, 1–10.
- Prisco, G.D., Zhang, X., Pennacchio, F., Caprio, E., Li, J., Evans, J.D., DeGrandi-Hoffman, G., Hamilton, M., Chen, Y.P., 2011. Dynamics of persistent and acute deformed wing virus infections in honey bees, *Apis mellifera*. *Viruses* 3, 2425–2441.
- Rozas, J., Ferrer-Mata, A., Sánchez-DelBarrio, J.C., Guirao-Rico, S., Librado, P., Ramos-Onsins, S.E., Sánchez-Gracia, A., 2017. DnaSP 6: DNA sequence polymorphism analysis of large datasets. *Mol. Biol. Evol.* 34, 3299–3302. <https://doi.org/10.1093/molbev/msx248>.
- Schittny, D., Yañez, O., Neumann, P., 2020. Honey bee virus transmission via hive products. *Vet. Sci.* 7, 96.
- Southwick, E.E., Southwick Jr, L., 1992. Estimating the economic value of honey bees (Hymenoptera: Apidae) as agricultural pollinators in the United States. *J. Econ. Entomol.* 85, 621–633.
- Tajima, F., 1989. Statistical method for testing the neutral mutation hypothesis by DNA polymorphism. *Genet.* 123, 585–595.
- Tamura, K., Stecher, G., Peterson, D., Filipiński, A., Kumar, S., 2013. MEGA6: molecular evolutionary genetics analysis version 6.0. *Mol. Biol. Evol.* 30, 2725–2729.
- Tentcheva, D., Gauthier, L., Bagny, L., Fievet, J., Dainat, B., Cousserans, F., Colin, M.E., Bergoin, M., 2006. Comparative analysis of deformed wing virus (DWV) RNA in *Apis mellifera* and *Varroa destructor*. *Apidologie* 37, 41–50.
- vanEngelsdorp, D., Evans, J.D., Saegerman, C., Mullin, C., Haubruge, E., Nguyen, B.K., Frazier, M., Frazier, J., Cox-Foster, D., Chen, Y., Underwood, R., Tarpy, D.R., Pettis, J.S., 2009. Colony collapse disorder: A descriptive study. *PLoS ONE* 4. <https://doi.org/10.1371/journal.pone.0006481> e6481.
- Yue, C., Genersch, E., 2005. RT-PCR analysis of deformed wing virus (DWV) in honey bees (*Apis mellifera*) and mites (*Varroa destructor*). *J. Gen. Virol.* 86, 3419–3425.