

Article

## Design of a Functional Training Prototype for Neonatal Resuscitation

Sivaramakrishnan Rajaraman \*, Sona Ganesan, Kavitha Jayapal and Sadhani Kannan

Department of Biomedical Engineering, Sri Sivasubramaniya Nadar College of Engineering, Kalavakkam, 603 110 Tamil Nadu, India; E-Mails: sonatamilselvi@gmail.com (S.G.); kavithajayapalb@gmail.com (K.J.); sadhanikannan@gmail.com (S.K.)

\* Author to whom correspondence should be addressed; E-Mail: sivaramakrishnanr@ssn.edu.in; Tel.: +91-44-2747-4844; Fax: +91-44-2747-5063.

External Editor: Sari Acra

Received: 2 September 2014; in revised form: 6 November 2014 / Accepted: 7 November 2014 / Published: 20 November 2014

---

**Abstract:** Birth Asphyxia is considered to be one of the leading causes of neonatal mortality around the world. Asphyxiated neonates require skilled resuscitation to survive the neonatal period. The project aims to train health professionals in a basic newborn care using a prototype with an ultimate objective to have one person at every delivery trained in neonatal resuscitation. This prototype will be a user-friendly device with which one can get trained in performing neonatal resuscitation in resource-limited settings. The prototype consists of a Force Sensing Resistor (FSR) that measures the pressure applied and is interfaced with Arduino<sup>®</sup> which controls the Liquid Crystal Display (LCD) and Light Emitting Diode (LED) indication for pressure and compression counts. With the increase in population and absence of proper medical care, the need for neonatal resuscitation program is not well addressed. The proposed work aims at offering a promising solution for training health care individuals on resuscitating newborn babies under low resource settings.

**Keywords:** birth asphyxia; neonatal mortality; newborn care; neonatal resuscitation; force sensing resistor; compression count

---

## 1. Introduction

Neonatal Mortality Rate (NNMR) is defined as the number of infant deaths that occur in less than 29 days from birth for every thousand live births for a given year. The NNMR rate is rapidly increasing around the world and is the most prominent in rural regions. About 10% of neonatal mortality is caused due to birth asphyxia [1]. The statistics for the causes of child mortality is shown in Figure 1. Asphyxiated neonates require skilled resuscitation to survive the neonatal period. Lack of trained medical staff, along with poor health infrastructures, is one of the major hurdles in ensuring quality neonatal care.

**Figure 1.** Statistics for causes of child mortality.

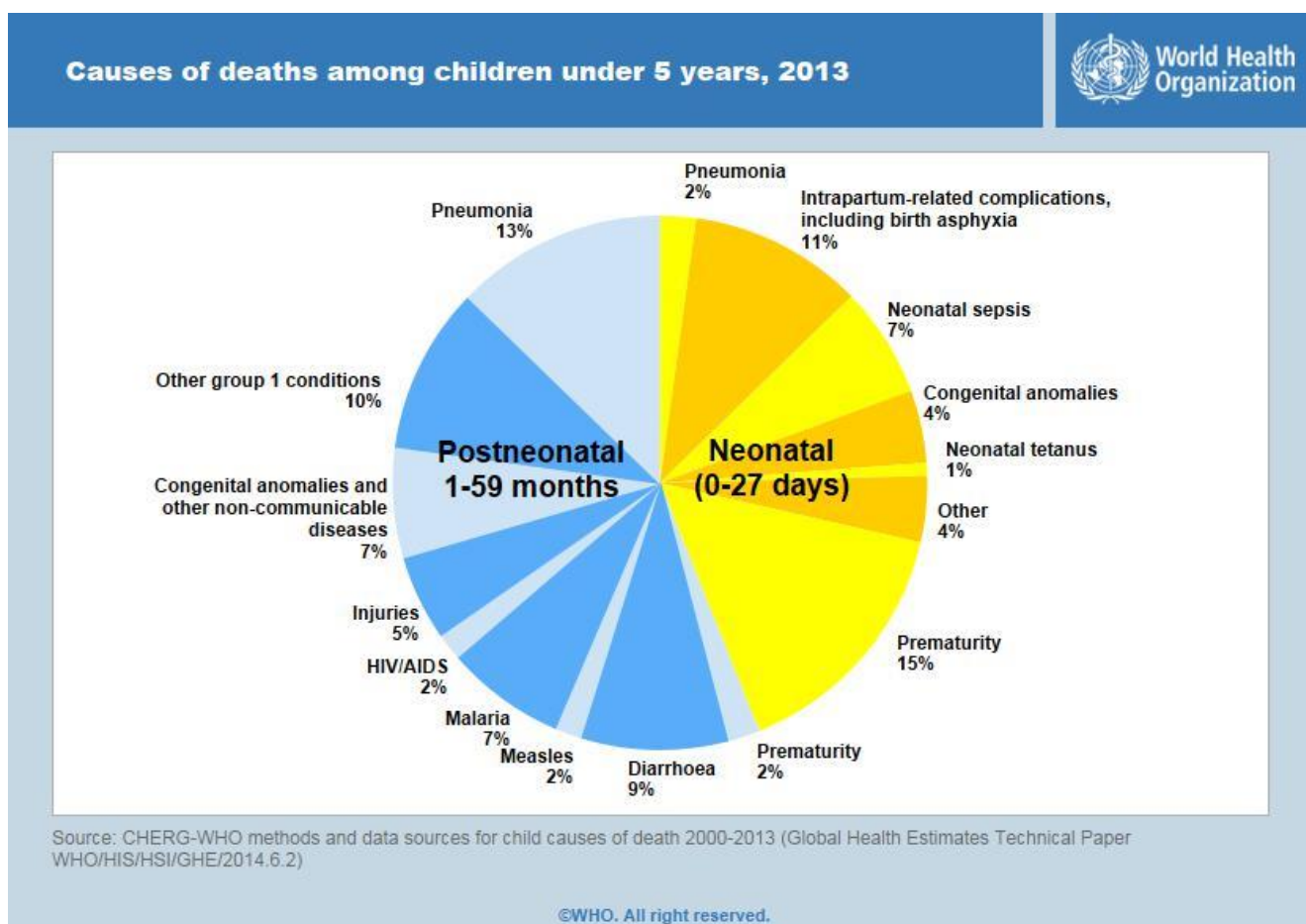

Neonatal mortality constitutes about 75% of infant deaths around the world. It is therefore essential that neonates be provided the utmost care at the first month of life so that neonatal deaths attributable to asphyxia, infection, and preterm births could be prevented [2]. The 2006 World Health Report stresses that the probability of infant, child and maternal survival is positively correlated with increasing density of competent health workers [3]. Despite a rapid economic growth that has occurred around the world over the last two decades, the neonatal mortality rate continues to remain high, around 900,000 in 2007, and India accounts for nearly 28% of the global deaths among newborn children [4]. Causes, including preterm delivery (29%), asphyxia (23%) and severe infections, such as sepsis and pneumonia (25%), account for three quarters of neonatal deaths around the world. Existing

interventions can prevent two-thirds or more of these deaths if they reach those in need. Out of several million births each year, 4%–6% of neonates fail to establish spontaneous breathing at birth. Proper assistance can be provided to babies, if healthcare professionals present at the time of birth are skilled in the art of neonatal resuscitation [5]. There are more than a million neonatal deaths occurring in India every year and that accounts for almost a quarter of all the neonatal deaths across the world. As the quality of Cardiopulmonary Resuscitation (CPR) makes a huge difference between life and death, there is a huge demand for effective CPR training [6].

CPR is a medical procedure that involves both compression and ventilation for the survival of a newborn. The first step involves clearing the airway. When the heart rate is less than 100 beats per minute, assisted ventilation must be provided using an endo-tracheal tube or a bag valve mask, called by its proprietary name as AMBU bag. When the heart rate is less than 60 beats per min, assisted ventilation along with chest compressions has to be performed. Chest compressions can be done in two ways: two fingers method and thumb encircling the chest method. Figure 2 depicts the steps involved in neonatal resuscitation. The goals of neonatal resuscitation are to prevent morbidity and mortality associated with hypoxic-ischemic tissue injury of the human organs and also to reestablish adequate spontaneous respiration and cardiac output [7].

**Figure 2.** (A) Clearing the airway; (B) Providing assisted ventilation; (C) Two fingers method for compression; (D) Thumb encircling the chest method for compression.

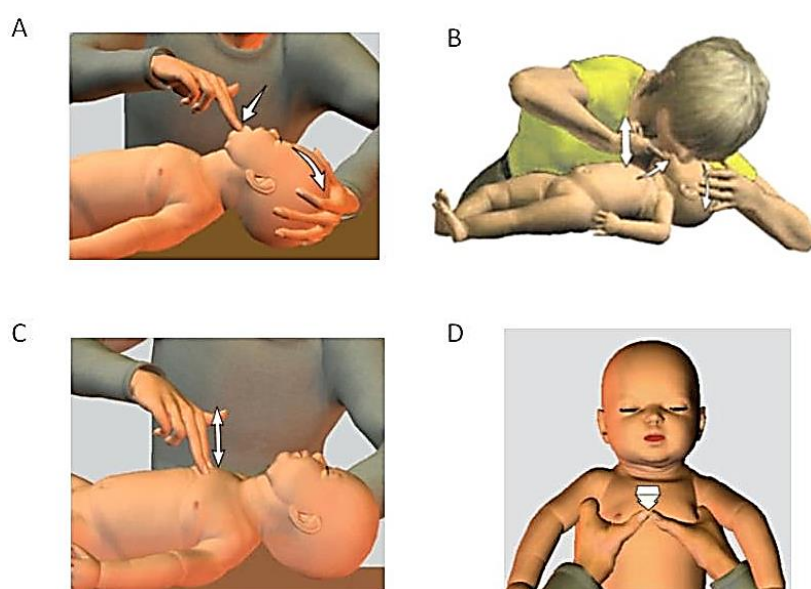

When complications such as asphyxia or severe infection arise that lead to cessation of breathing and decrease of heart rate, it is difficult to maintain the right rhythm and correct ratio of insufflations to chest compressions and to exert the compressions at a constant pressure while performing CPR [8]. CPR procedures are clearly described in the neonatal resuscitation guidelines of the American Heart Association [9]. When apnea persists and the heart rate is below 60 Beats per Minute (BPM), actual CPR should be instituted. CPR should be carried out with two persons, one performing insufflations and the other performing chest compressions. The ratio of insufflations and chest compressions should be 1:3. During the stress due to an acute situation, even for the medical staff, it is difficult to maintain the right rhythm and correct ratio of insufflations to compressions and to exert the compressions at a

constant pressure [10]. On one hand, improper chest compressions could cause injury to the internal organs [11]. On the other hand, soft compressions could lead to lack of depth in compression, and, thus, it becomes mandatory to provide hands-on training to the attendants working on CPR. There are a few critical requirements for high-quality CPR that includes appropriate chest compressions at the exact depth and rate and to maintain a proper stature while doing compressions and avoiding disproportionate ventilation [12]. The quality of external chest compressions is the key component of basic life support. Different approaches are used to improve the performance that was evaluated using visual feedback [13]. The drawback of the method was an absence of indication for the compression count and audio feedback. The relationship between ventilation and chest compression was explained. There was an inverse relationship between intra-thoracic pressures and coronary perfusion pressures and subsequent survival from cardiac arrest [14]. Basic resuscitation would substantially reduce neonatal deaths. The practitioner needs to identify the delay between the intra and extra-uterine physiology and provide appropriate neonatal transition to support spontaneous breathing and cardiopulmonary functions [15]. When a baby is born in medical facilities, care must be taken to ensure that all birth attendants are competent in resuscitation. Innovative strategies to address the problems faced in home births are urgently required. Sufficient data are required to document the impact of neonatal resuscitation, particularly on long-term results in low-resource settings [16]. With the increase in population and absence of proper medical care, the need for Neonatal Resuscitation Program (NRP) is not well addressed. The Indian Academy of Pediatrics (IAP) provides NRP training to all the health care professionals who are involved in delivery or immediate interventions after delivery to provide appropriate medical care to the neonates [17].

The prototype reported in reference [8] provides a visual feedback with electroluminescent foil actuators for indication of the exerted chest compression pressure. It also provides audio feedback, which produces different sounds as audio guidance for providing ventilation and compressions but recording of the number of compressions and the pressure levels is performed by a separate evaluation mannequin embedded with sensors. However, the proposed technique helps to keep track of the pressure applied on the neonates and the number of compressions given per minute. The visual feedback provides the display for the pressure applied and the number of compressions given and helps in controlling the pressure if exceeded. The audio feedback gives an alarm if the pressure applied is very high.

The proposed work is aimed to design a functional training prototype for neonatal resuscitation to assist healthcare professionals in providing the most appropriate resuscitation to the neonates. The functional prototype is equipped with a visual and audio feedback that evaluates the performance of CPR. Special attention has been given towards its use in the most sensitive Neonatal Intensive Care Unit (NICU) environment, considering the power level, reliability of the sensors with respect to temperature fluctuations, and sensitivity to noise and heat variations. With the use of display and audio devices, the feedback on the performance of the healthcare trainee is received. Thus, this work aims to design a resuscitation tool that is specifically oriented to performing neonatal resuscitation in human resource-limited settings.

## 2. Materials and Methods

The schematic representation of the prototype is depicted in Figure 3. A Force sensing resistor (FSR) is used for measuring the applied pressure. FSR, known for its smaller size and low power consumption can be easily embedded into the system. The controller, to which the FSR is interfaced with, is Arduino<sup>®</sup>, an open source platform available for electronics prototyping for creating interactive environments [18].

The FSR is connected through the voltage divider circuit. The pressure display unit consists of Liquid Crystal Display (LCD) that is connected to the digital ports of Arduino<sup>®</sup>. The pressure ranges are classified using the data obtained from the calibration procedure and displayed on the LCD. An alarm circuit is connected in parallel with the LCD and the buzzer goes off when the pressure exceeds the required level. The number of compressions per minute is provided by Light Emitting Diode (LED) indications. Different counts in the order of 15, 30, 60 and 100 are displayed in different colors. The prototype is tested with a mannequin and the results are validated. Figure 4 shows the overall prototype.

**Figure 3.** Block diagram of the prototype.

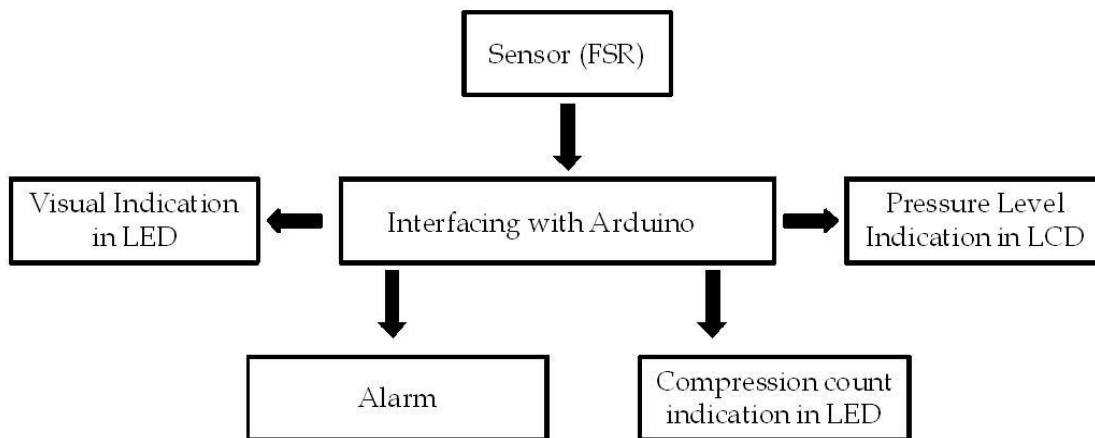
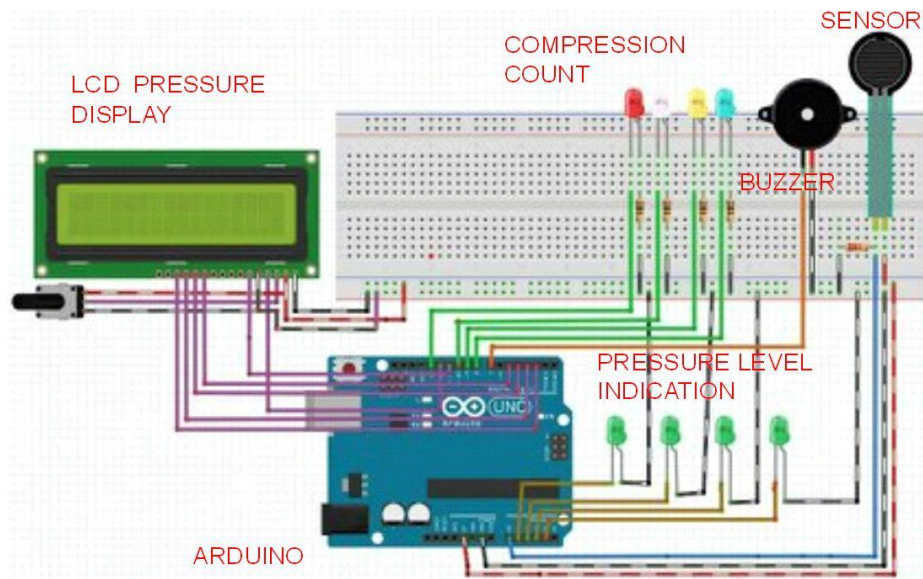

Figure 4. Overall prototype.



### 2.1. Arduino with ATmega8

Arduino<sup>®</sup> is an open source prototyping platform based on simple hardware and software. The controller used is Arduino<sup>®</sup> with an inbuilt low power CMOS 8-bit Atmega8 Microcontroller. The microcontroller has 8KB of in system programmable flash program memory that stores the program codes. It also includes 512Kb of EEPROM and 1Kb of SRAM. Atmega8 is a powerful microcontroller that provides a highly flexible and cost effective solution for many embedded control applications.

### 2.2. Pressure Display and Compression Count

The program starts with the recording of analog readings obtained from the sensor output with which the applied pressure condition is checked. The pressure ranges are categorized depending on the analog values. Using these values, the algorithm is developed to display the pressure range on an LCD as shown in Figure 5A. During program compilation, the number of times the sensor is being compressed is counted. Depending upon the number of counts, indications are provided using different colors of LED. When the count reaches 15, 30, 60 and 100, the corresponding pins 7,8,13 and 10 go high and the red, white, yellow and green LEDs glow, respectively. The flow of the compression count unit is shown in Figure 5B.

**Figure 5.** (A) Flowchart illustrating the flow of pressure display system; (B) Flowchart illustrating the compression count unit.

A

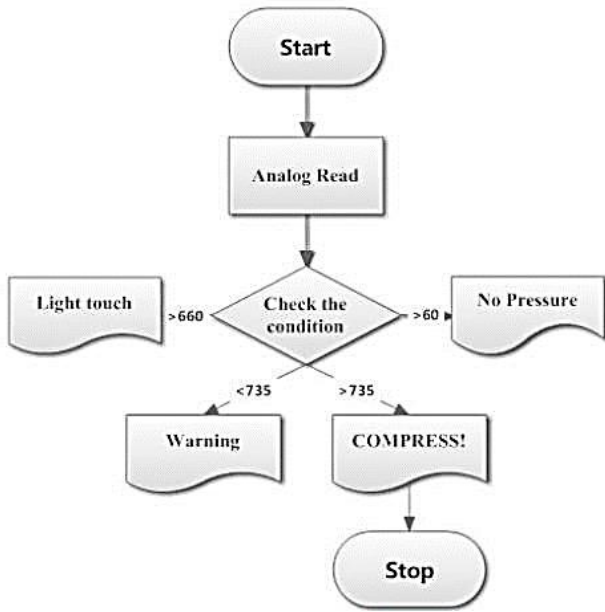

B

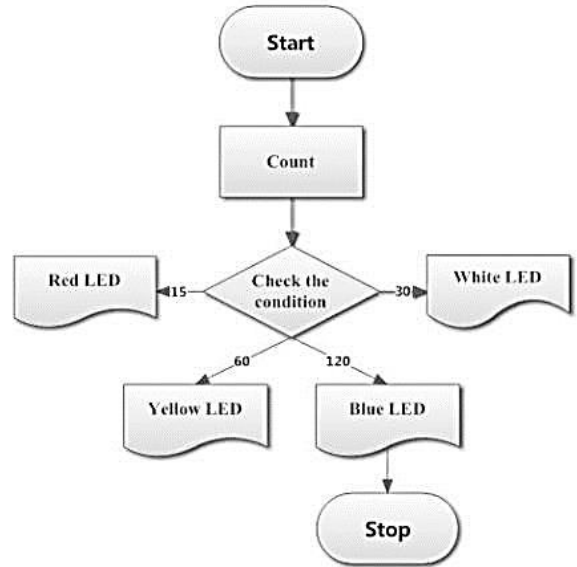

2.3. Force Sensing Resistor (FSR)

FSR is a piezo-resistive polymer whose resistance changes when a force is applied. It exhibits a decrease in resistance with increase in force applied to the sensor. The force sensitivity range is between 0.1 and 100 N. The sensor is about 18.28 mm in diameter and 0.2 to 1.25 mm in thickness [19]. Figure 6 shows the voltage driver circuit. The sensor is connected to the Arduino® using a voltage divider circuit. The voltage divider circuit provides the output voltage across two resistors connected in series. The FSR and the resistor form a voltage divider, which divides the supply voltage between the two resistances. The analog voltage “V<sub>0</sub>” is given by Equation (1):

$$V_0 = V_{cc} (R / (R + \text{value of FSR})) \tag{1}$$

Figure 6. Voltage divider circuit.

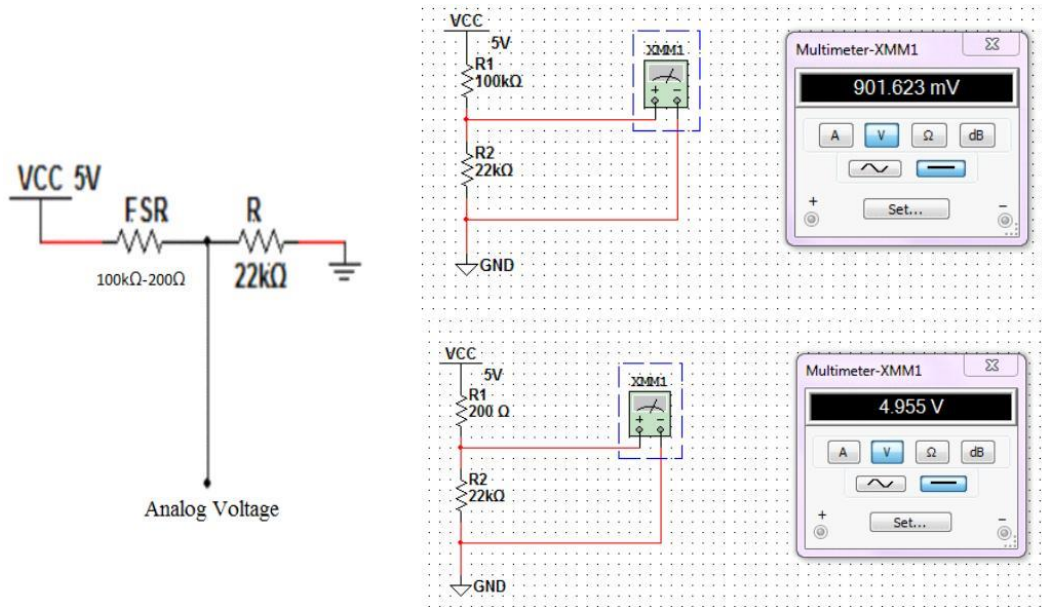

3. Results and Discussion

The sensor and FSR are calibrated against known values of weights say 30, 35, up to 700 grams. The resistance and the corresponding voltage are measured using a digital multimeter as shown in Figure 7. Table 1 shows the resistance and conductance measured for different weights. The force was calculated as per Equation (2).

$$F=mg \tag{2}$$

Where “m” is the mass in kilograms and “g” is acceleration due to gravity ( $g = 9.8 \text{ ms}^{-2}$ ). Table 2 shows the voltage measured for different weights. Table 3 displays the pressure values and the corresponding analog read values. The pressure is calculated from force using the diameter of the sensor. The values of resistance decrease with increase in weights as observed from Table 1. The values of voltage increase with increase in force but do not increase beyond 5 volts as observed from Table 2.

Figure 7. (A) Measurement of resistance; (B) Measurement of voltage.

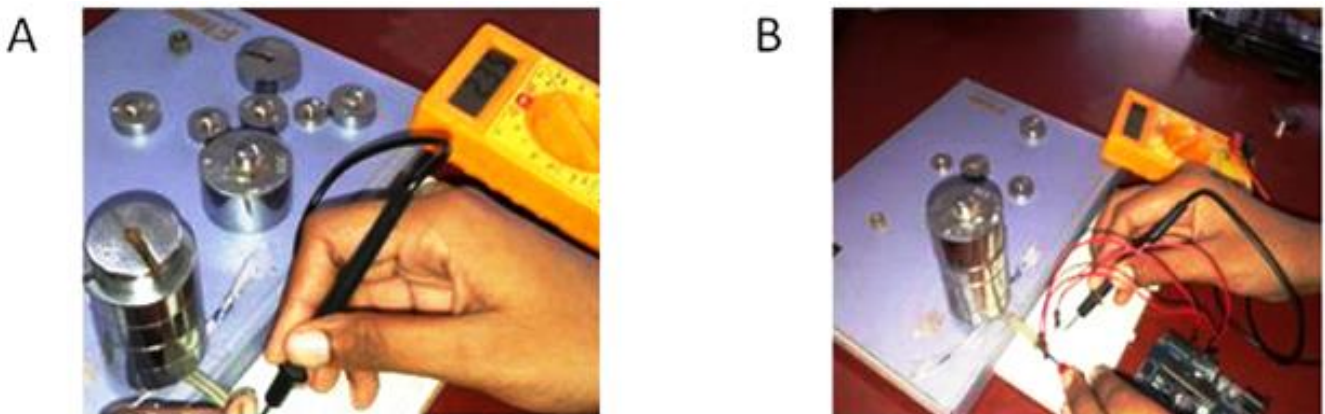



**Table 1.** Measurement of force resistance and conductance for varying values of weights.

Weight (in gms.)	Force (in N)	Resistance (in k $\Omega$ )
30	0.294	210.15
35	0.343	136
40	0.392	109.2
45	0.441	62
50	0.49	33.7
60	0.588	22.1
70	0.686	16.7
80	0.784	14.05
90	0.882	12.55
100	0.98	11.55
125	1.225	8.765
150	1.47	7
175	1.715	5.955
200	1.96	5.1
250	2.45	4.13
300	2.94	3.505
350	3.43	3.1
400	3.92	2.805
450	4.41	2.46
500	4.9	2.315
600	5.88	2.19
650	6.37	1.985
700	6.86	1.89

**Table 2.** Measurement of voltage for varying values of weights.

Weight (in gms.)	Force(in N)	Voltage(in V)
30	0.294	2.23333
35	0.343	2.40333
40	0.392	2.65333
45	0.441	2.79
50	0.49	2.9
60	0.588	3.08333
70	0.686	3.00667
80	0.784	3.22
90	0.882	3.45
100	0.98	3.57333
125	1.225	3.76
150	1.47	3.98667
175	1.715	4.15667
200	1.96	4.24
250	2.45	4.39667
300	2.94	4.47
350	3.43	4.5667

**Table 2.** *Cont.*

<b>Weight (in gms.)</b>	<b>Force (in N)</b>	<b>Voltage (in V)</b>
400	3.92	4.63
450	4.41	4.69
500	4.9	4.71
600	5.88	4.70667
650	6.37	4.71
700	6.86	4.71

**Table 3.** Pressure and the corresponding analog read values.

<b>Analog Read</b>	<b>Force(in N)</b>	<b>Pressure(in N/m<sup>2</sup>)</b>
457	0.294	1121
492	0.343	1308
543	0.392	1494
571	0.441	1681
593	0.49	1868
631	0.588	2242
615	0.686	2615
659	0.784	2989
706	0.882	3362
731	0.98	3736
769	1.225	4670
816	1.47	5604
850	1.715	6538
868	1.96	7472
900	2.45	9340
915	2.94	11208
934	3.43	13076
947	3.92	14944
960	4.41	16812
964	4.9	18680
963	5.88	22416
964	6.37	24284

The normal pressure for neonatal resuscitation is about 30–40 cm of H<sub>2</sub>O [20]2900–3900 N/m<sup>2</sup>. With reference to the normal pressure, the different pressures are categorized. The pressures less than this reference pressure are categorized as light pressures and pressures higher than the reference pressure are categorized as warning. With reference to this pressure, the pressure ranges are categorized and programmed using Arduino<sup>®</sup>. The prompts on the LCD are displayed according to the force sensed by the sensor. A visual feedback is given that provides the trainee, the necessary instructions during the procedure. Figure 8 shows a comparison of the plot of various values as obtained from the datasheet and from the calibration process. Figure 9A shows the LCD outputs of different pressure levels and their corresponding ranges. A buzzer connected to pin 9 of Arduino<sup>®</sup> monitors the pressure level when the program starts running, and when the pressure level exceeds the required level, the buzzer goes off. Figure 9B depicts the alarm unit. The output from the serial

monitor of Arduino® is shown in Figure 9C. The combined rate of compressions and ventilation can be in the ratio 3:1 and this would provide 90 compressions and 30 breaths/minute [7]. Figure 9D shows the visual indication to keep track of the number of compressions given per minute.

**Figure 8.** (A) Force vs. resistance obtained from datasheet; (B) Force vs. resistance obtained from calibration values; (C) Force vs. voltage obtained from datasheet; (D) Force vs. voltage obtained from calibration values.

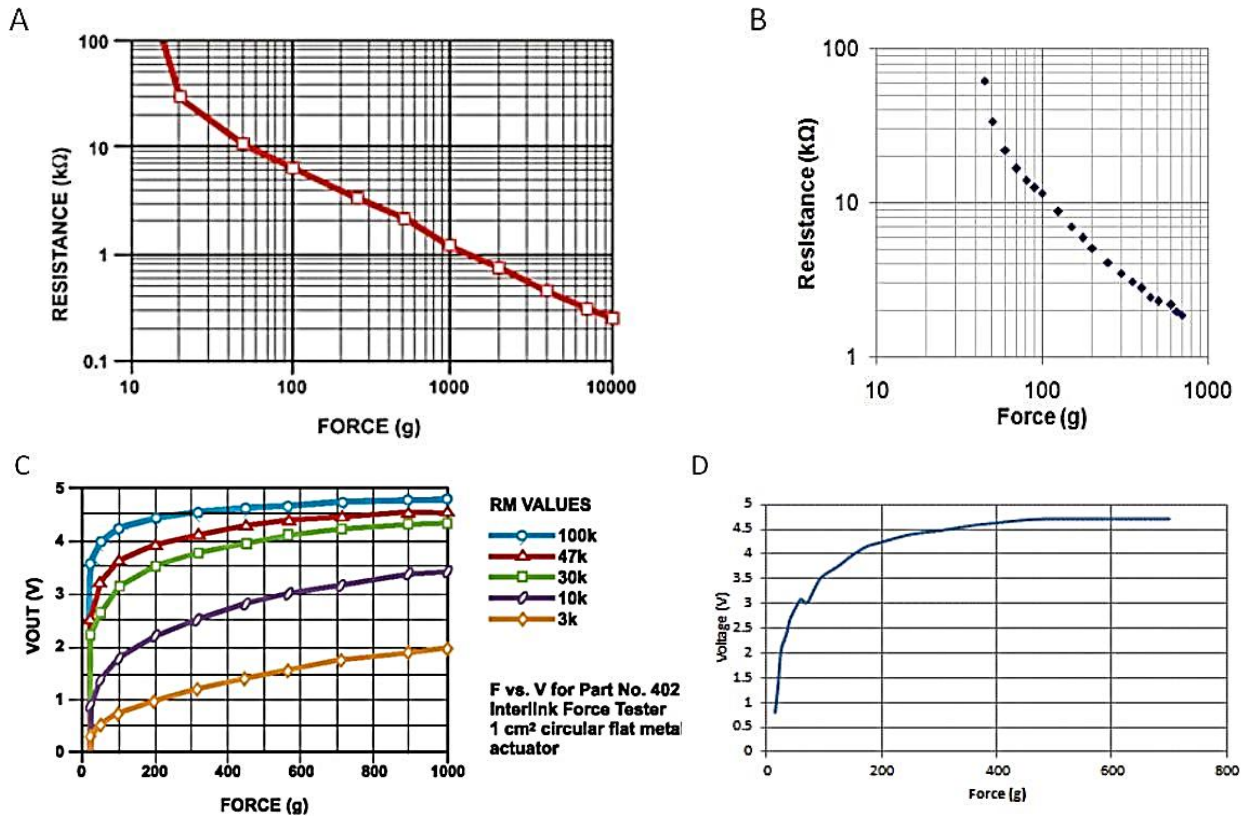

**Figure 9.** (A) Display for pressure ranges; (B) Alarm unit; (C) Output of serial monitor; (D) Compression count indication.

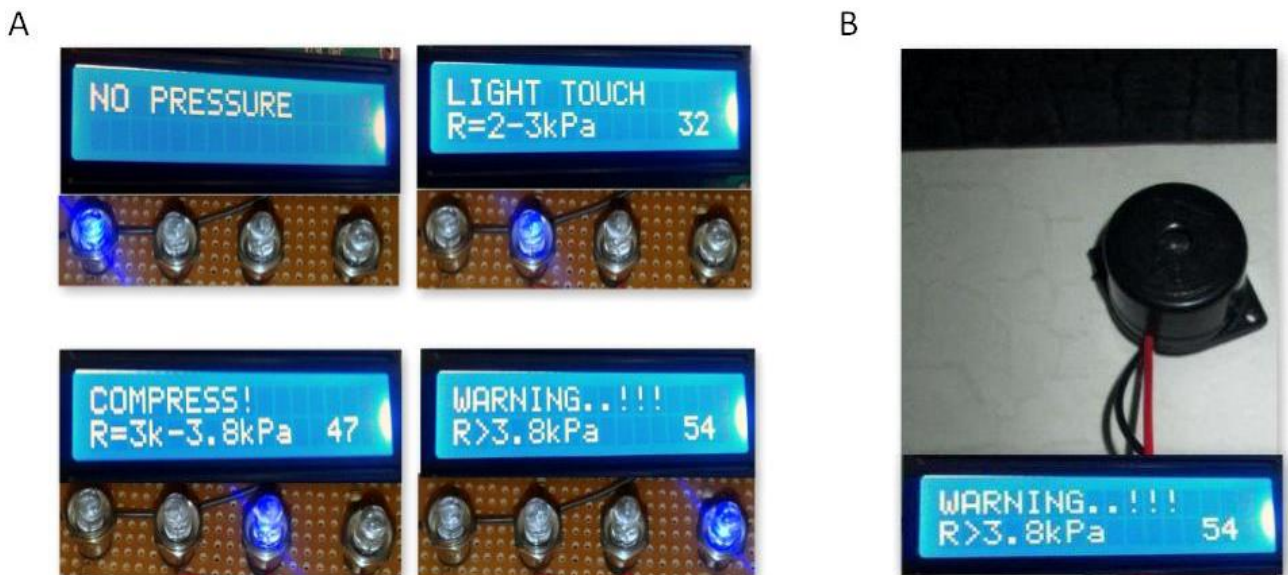

Figure 9. Cont.

C

```

COM3
-----
Analog reading = 2
Voltage reading in mV = 9
FSR resistance in ohms = 12200222
Conductance in microMhos = 0
No pressure
compress_count :0
-----
Analog reading = 546
Voltage reading in mV = 2668
FSR resistance in ohms = 19229
Conductance in microMhos = 52
Light touch
compress_count :0
count :10
-----
Analog reading = 724
Voltage reading in mV = 3538
FSR resistance in ohms = 9091
Conductance in microMhos = 109
COMPRESS!
compress_count :1
count :11
-----
Analog reading = 809
Voltage reading in mV = 3954
FSR resistance in ohms = 5819
Conductance in microMhos = 171
WARNING
compress_count :0
count :12
-----
Analog reading = 10
Voltage reading in mV = 48
FSR resistance in ohms = 2269666
Conductance in microMhos = 0
No pressure
compress_count :0
-----
Autoscroll
    
```

D



#### 4. Validation

The prototype used for validation of the results is shown in Figure 10. The prototype was validated in the Diagnostic and Therapeutic Equipment laboratory at the Department of Biomedical Engineering, Sri Sivasubramaniya Nadar College of Engineering, with 30 people doing CPR on the mannequin with and without visual and audio feedback. The ratio of ventilation to compressions was maintained at 1:3 for neonates; that infers that for a single ventilation, three compressions were done. The rate of chest compression used for validation was 90–100 per minute. During the Validation process, the trainee was asked to perform chest compression and the values, such as compression count and warning count were recorded in Excel. The Arduino was interfaced with PLX-DAQ supported spreadsheet which recorded the value during the process of chest compression. Figure 11 shows the PLX-DAQ spreadsheet and the values which were recorded during the validation process without feedback. Figure 12 shows the PLX-DAQ spreadsheet and the values which were recorded during the validation process with feedback. In Figures 11 and 12, the column count refers to the total number of compressions given by the person; the column compress count refers to the number of required compressions *i.e.*, the pressure for performing CPR given by the person, and the column w count refers to the number of warning pressures provided. Figure 13 depicts the chart plotted based on the validation results. A graph is plotted using the obtained compression count and warning count and the comparison is studied.

It is observed that without feedback, the warning count percentage was about 66%. But with feedback, the percentage reduced to 30%. Similarly when the compression count is taken into account, the percentage increased from 1% to 3%, without feedback and with feedback, respectively. Hence, this prototype is a user-friendly device with which one can get trained in performing neonatal resuscitation in resource limited settings.

Figure 10. Testing prototype.

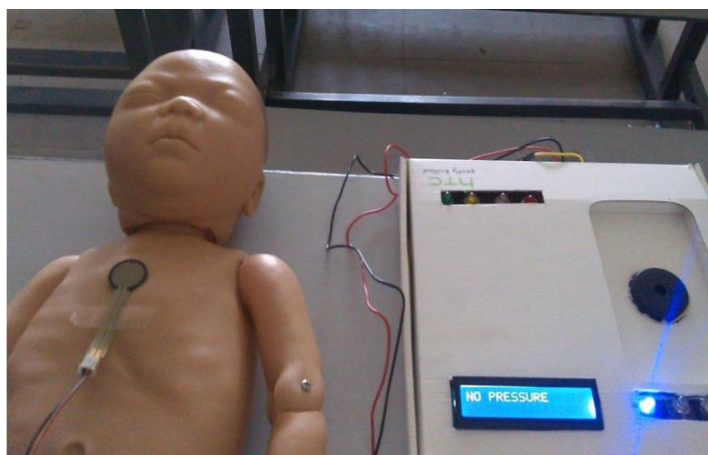

Figure 11. Without Feedback.

	A	B	C	D	E	F	G	H
1	Time	Analog Read	Resistan ce	Conduct ance	Voltage	count	compres s count	w_count
2	12:29:12	889.00	3316	301	4345	1	0	1
3	12:29:13	830.00	5120	195	4056	2	0	2
4	12:29:14	745.00	8211	121	3641	3	0	3
5	12:29:15	807.00	5890	169	3944	4	0	4
6	12:29:16	807.00	5890	169	3944	5	0	5
7	12:29:17	868.00	3931	254	4242	6	0	6
8	12:29:18	843.00	4699	212	4120	7	0	7
9	12:29:19	787.00	6601	151	3846	8	0	8
10	12:29:20	855.00	4328	231	4178	9	0	9
11	12:29:22	885.00	3433	291	4325	10	0	10
12	12:29:23	832.00	5053	197	4066	11	0	11
13	12:29:24	881.00	3551	281	4305	12	0	12
14	12:29:25	890.00	3293	303	4349	13	0	13
15	12:29:26	846.00	4608	217	4134	14	0	14
16	12:29:27	885.00	3433	291	4325	15	0	15
17	12:29:28	847.00	4576	218	4139	16	0	16
18	12:29:29	824.00	5315	188	4027	17	0	17
19	12:29:30	860.00	4171	239	4203	18	0	18
20	12:29:31	885.00	3433	291	4325	19	0	19
21	12:29:33	848.00	4544	220	4144	20	0	20
22	12:29:34	731.00	8795	113	3572	21	1	20
23	12:29:35	616.00	14544	68	3010	22	0	20
24	12:29:36	808.00	5855	170	3949	23	0	21

Figure 12. With Feedback.

	A	B	C	D	E	F	G	H
1	Time	Analog Read	Resistance	Conductance	Voltage	count	compress count	w_count
2	12:32:55	660.00	12108	82	3225	1	1	0
3	12:32:56	627.00	13900	71	3064	2	0	0
4	12:32:57	689.00	10670	93	3367	3	1	0
5	12:32:58	671.00	11546	86	3279	4	2	0
6	12:32:59	668.00	11700	85	3264	5	3	0
7	12:33:00	661.00	12055	82	3230	6	4	0
8	12:33:01	648.00	12733	78	3167	7	0	0
9	12:33:02	678.00	11202	89	3313	8	1	0
10	12:33:03	672.00	11495	86	3284	9	2	0
11	12:33:04	676.00	11292	88	3304	10	3	0
12	12:33:05	679.00	11152	89	3318	11	4	0
13	12:33:06	665.00	11846	84	3250	12	5	0
14	12:33:07	671.00	11546	86	3279	13	6	0
15	12:33:08	662.00	12003	83	3235	14	7	0
16	12:33:09	666.00	11794	84	3255	15	8	0
17	12:33:10	659.00	12161	82	3220	16	0	0
18	12:33:11	665.00	11846	84	3250	17	1	0
19	12:33:12	663.00	11950	83	3240	18	2	0
20	12:33:13	674.00	11394	87	3294	19	3	0
21	12:33:14	671.00	11546	86	3279	20	4	0
22	12:33:15	675.00	11343	88	3299	21	5	0

Figure 13. Validation chart.

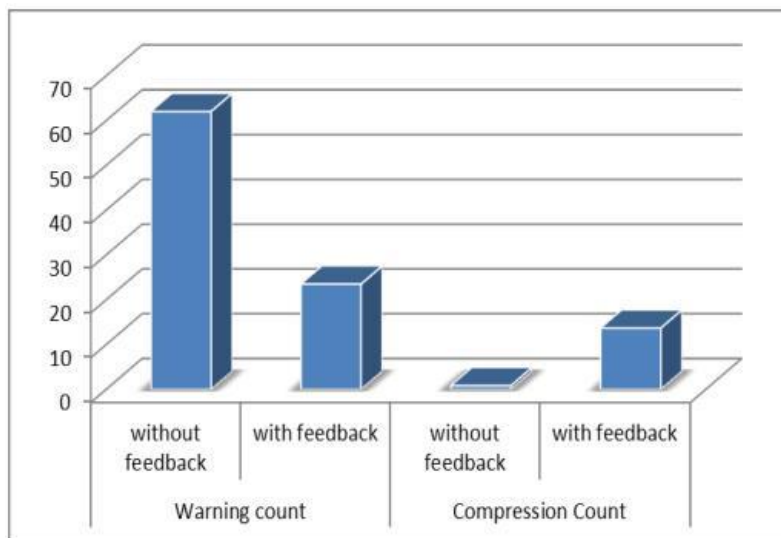

		%
Warning count	without feedback	62.03314
	with feedback	23.4841
Compression Count	without feedback	0.815047
	with feedback	13.66771

## 5. Conclusions

A prototype has been proposed to train health care professionals involved in the delivery of newborns or immediate interventions after delivery. The proposed technique helps to keep track of the pressure applied on the neonates and the number of compressions given per minute. Further, this prototype should be extremely helpful in Primary Health Centers (PHC) where there is inadequate manpower for training individuals. The work can be extended to measure more compression characteristics, including compression depth, frequency and acceleration. Further enhancements could be done by making the prototype wireless, self-powered and easily portable.

## Author Contributions

All the authors contributed equally towards the development of the prototype. Sivaramakrishnan Rajaraman and Sona Ganesan created the prototype and analyzed the data. Kavitha Jayapal and Sadhani Kannan validated the results and prepared the manuscript.

## Conflicts of Interest

The authors declare no conflict of interest.

## References

1. World Health Organization. Available online: [http://www.who.int/gho/child\\_health/mortality/causes/en/](http://www.who.int/gho/child_health/mortality/causes/en/) (accessed on 2 March 2014).
2. Open Government Data Platform India. Available online: <http://data.gov.in/keywords/1000-live-births/> (accessed on 2 March 2014).
3. World Health Report. Available online: <http://www.who-int/whr/2006/en/> (accessed on 10 March 2014).
4. Mathews, T.J.; MacDorman, M.F. Infant mortality statistics from the 2007 period linked birth/infant death data set. *Natl. Vital Stat. Rep.* **2011**, *59*, 1–30.
5. Deorari, A.K.; Paul, V.K.; Singh, M.; Vidyasagar, D. The national movement of neonatal resuscitation in India. *J. Trop. Pediatr.* **2000**, *46*, 315–317.
6. Choudhury, P. Neonatal Resuscitation Program: First golden minute. *Indian Pediatr.* **2009**, *46*, 7–9.
7. CALS Neonatal Emergencies. Available online: [https://calsprogram.org/manual/volume1/Section4\\_Path/05-PATH4NeonatalEmergencies13.html/](https://calsprogram.org/manual/volume1/Section4_Path/05-PATH4NeonatalEmergencies13.html/) (accessed on 13 March 2014).
8. Chen, W.; Oetomo, S.B.; Feijs, L.; Andriessen, P.; Kimman, F.; Geraets, M.; Thielen, M. Rhythm of Life Aid (ROLA: An integrated sensor system for supporting medical staff during cardiopulmonary resuscitation (CPR) of newborn infants. *IEEE Trans. Inf. Technol. Biomed.* **2010**, *14*, 1468–1474.
9. Nolan, J.P.; Soar, J.; Zideman, D.A.; Biarent, D.; Bossaert, L.L.; Deakin, C.; Koster, R.W.; Wyllie, J.; Bottiger, B. European Resuscitation Council Guidelines for resuscitation 2010. *Resuscitation* **2010**, *81*, 1219–1276.
10. Donnelly, P.D.; Lester, C.A.; Morgan, C.L.; Assar, D.H. Effectiveness of the BBC's 999 training roadshows on cardiopulmonary resuscitation: Video performance of cohort of unforeswarned participants at home six months afterwards. *Br. Med. J.* **1996**, *313*, 912–916.

11. Frink, R.J.; Rose, J.P. Cardiopulmonary resuscitation and direct cardiac injury: Evidence of fractured coronary arteries and HIS bundle hemorrhage. *J. Invasive Cardiol.* **1997**, *9*, 578–585.
12. Meaney, P.A.; Bobrow, B.J.; Mancini, M.E.; Christenson, J.; Caen, A.R.; Abella, B.S.; Edelson, D.P.; Berg, R.A. Cardiopulmonary resuscitation quality: Improving cardiac resuscitation outcomes both inside and outside the hospital: A consensus statement from the American Heart Association. *Circulation* **2013**, *128*, 417–435.
13. Skorning, M.; Beckers, S.K.; Brokmann, J.; Rortgen, D.; Bergrath, S.; Veiser, T.; Heussen, N.; Rossaint, R. New visual feedback device improves performance of chest compressions by professionals in simulated cardiac arrest. *Resuscitation* **2010**, *81*, 53–58.
14. Bobrow, B.J.; Ewy, G.A. Ventilation during resuscitation efforts for out-of-hospital primary cardiac arrest. *Curr. Opin. Crit. Care* **2009**, *15*, 228–233.
15. Neonatal Resuscitation. Available online: <http://emedicine.medscape.com/article/977002-overview/> (accessed on 10 March 2014).
16. Wall, S.N.; Lee, A.C.; Niermeyer, S.; English, M.; Keenan, W.J.; Carlo, W.; Bhutta, Z.A.; Bang, A.; Narayanan, I.; Ariawan, I.; *et al.* Neonatal resuscitation in low-resource settings: What, who, and how to overcome challenges to scale up? *Int. J. Gynecol. Obstet.* **2009**, *107*, 47–64.
17. Indian Academy of Pediatrics. Available online: <http://www.iapnrpfgm.org/cms/index.php/> (accessed on 6 April 2014).
18. ARDUINO Home Page. Available online: <http://www.arduino.cc/> (accessed on 4 March 2014).
19. FSR 402 Datasheet. Available online: <http://www.trossenrobotics.com/productdocs/2010-10-26-DataSheet-FSR402-Layout2.pdf/> (accessed on 1 May 2014).
20. Kattwinkel, J.; Periman, J.M.; Aziz, K.; Colby, C.; Fairchild, K.; Gallagher, J.; Hazinski, M.F.; Halamek, L.P.; Kumar, P.; Little, G.; *et al.* Neonatal resuscitation: 2010 American Heart Association Guidelines for cardiopulmonary resuscitation and emergency cardiovascular care. *Pediatrics* **2010**, *126*, e1400–e1413.

© 2014 by the authors; licensee MDPI, Basel, Switzerland. This article is an open access article distributed under the terms and conditions of the Creative Commons Attribution license (<http://creativecommons.org/licenses/by/4.0/>).