

Mechanism of Action of K Channel Openers on Skeletal Muscle K_{ATP} Channels

Interactions with Nucleotides and Protons

CYRILLE FORESTIER, JÉRÔME PIERRARD, and MICHEL VIVAUDOU

From Laboratoire de Biophysique Moléculaire et Cellulaire (Unité de Recherche Associée 520 du Centre National de la Recherche Scientifique), Département de Biologie Moléculaire et Structurale, Commissariat à l'Energie Atomique, 38054 Grenoble, France

ABSTRACT The molecular mechanisms underlying the actions of K channel openers (KCOs) on K_{ATP} channels were studied with the patch clamp technique in excised inside-out patches from frog skeletal muscle fibers. Benzopyran KCOs (levcromakalim and SR 47063) opened channels partially blocked by ATP, ADP, or ATPγS, with and without Mg^{2+} , but they had no effects in the absence of internal nucleotides, even after channel activity had significantly declined because of rundown. The effects of KCOs could therefore be attributed solely to a competitive interaction between KCOs and nucleotides, as confirmed by observations that ATP decreased the apparent affinity for KCOs and that, conversely, KCOs decreased ATP or ADP sensitivity. Protons antagonized the action of the non-benzopyran KCOs, pinacidil and aprikalim, by enhancing their dissociation rate. This effect resembled the effect of acidification on benzopyran KCOs (Forestier, C., Y. Depresle, and M. Vivaudou. *FEBS Lett.* 325:276–280, 1993), suggesting that, in spite of their structural diversity, KCOs could act through the same binding sites. Detailed analysis of the inhibitory effects of protons on channel activity induced by levcromakalim or SR 47063 revealed that, in the presence of 100 μ M ATP, this effect developed steeply between pH 7 and 6 and was half maximal at pH 6.6. These results are in quantitative agreement with an allosteric model of the K_{ATP} channel possessing four protonation sites, two nucleotidic sites accessible preferentially to Mg^{2+} -free nucleotides, and one benzopyran KCO site. The structural implications of this model are discussed.

INTRODUCTION

ATP-sensitive K^+ (K_{ATP}) channels have been found in many tissues (Ashcroft and Ashcroft, 1990; Gopalakrishnan et al., 1993), in particular skeletal muscle, in which they were discovered in 1985 (Spruce et al., 1985). K_{ATP} channels owe their name to their sensitivity to blockade by intracellular ATP, a feature that distinguishes them from other types of K^+ channels. However, these channels are regulated not only by ATP, but also by other cytosolic constituents such as Mg^{2+} , ADP, and protons, and it is believed that these regulations converge in such a way that K_{ATP} channels tend to open as metabolic energy decreases (Gopalakrishnan et al., 1993). K_{ATP} channels would therefore serve to adjust membrane excitability to cell metabolism. Accordingly, they

appear to be major players in phenomena involving changes in energy status, e.g., muscle fatigue (Castle and Haylett, 1987), ischemia, hypoxia (Coetzee, 1992), or glucose-dependent insulin release (Rorsman et al., 1994). They might also intervene in arterial hypertension because drugs that activate K_{ATP} channels in vitro relax vascular smooth muscle in vivo (Gopalakrishnan et al., 1993). Drugs acting on K_{ATP} channels therefore have a good therapeutic potential. Indeed, K_{ATP} channel blockers such as glibenclamide or tolbutamide are used routinely as hypoglycemic agents, and K_{ATP} channel openers (KCOs) such as pinacidil or cromakalim are being tested in a number of pathologic conditions (Gopalakrishnan et al., 1993).

In the search for better drugs, with higher affinity and greater tissue specificity, it would be very useful to obtain a better understanding of the mechanisms of action of these pharmacological agents. In this article, we have focused on the effects of KCOs on skeletal muscle K_{ATP} channels and have examined their mechanism of action in relation with nucleotides and protons, which are the main endogenous regulators of these channels.

In skeletal muscle, protons are potent activators of

Address correspondence to Dr. Michel Vivaudou, CENG/DBMS-BMC, 17 rue des Martyrs, 38054, Grenoble Cedex 9, France. Fax: (212) 860-3369; E-mail: vivaudou@msvax.mssm.edu

Dr. Forestier's present address is CEA, DPVE-SBC, 13108 St-Paul-Lez-Durance, France.

Dr. Pierrard's present address is Rhône-Poulenc, Dept. des Biotechnologies, BP 91693, 69263 Lyon, France.

K_{ATP} channels at concentrations within the physiological range (Davies et al., 1992; Vivaudou and Forestier, 1995). In a previous study (Vivaudou and Forestier, 1995) we presented data that reinforced the hypothesis that protons act by competing with nucleotides (Davies et al., 1992), and we proposed a reactional model that accounted for all observations on proton-induced changes in ATP sensitivity and ATP-induced changes in pH dependence. To compare the natural activators, protons, with the synthetic ones, KCOs, parallel experiments were conducted to examine how benzopyran KCOs (bKCOs) interact with nucleotides. These experiments, which constitute the first part of the present study, revealed strong similarities between bKCOs and protons.

The second part of this study is concerned with the interactions between KCOs and protons. We have already described the peculiar effect of protons on the action of bKCOs (Forestier et al., 1993). This previous work demonstrated that protons antagonized the activation by bKCOs by reducing their affinities for the K_{ATP} channel. It is extended here in two directions: on the one hand, we have studied the specificity of the interaction proton-activator by testing two non-benzopyran KCOs, pinacidil and aprikalim. On the other hand, we have tried to quantify this interaction by studying its pH dependence in greater details.

In the last part of this study, the mechanistic implications of these observations are discussed, and we present an allosteric model of the K_{ATP} channel capable of predicting with accuracy all of our experimental data.

Preliminary accounts of this work have been published in abstract form (Forestier and Vivaudou, 1993*b*; Forestier et al., 1995).

MATERIALS AND METHODS

The methods used in this work were similar to those described in a recent publication (Vivaudou and Forestier, 1995). Ionic currents were recorded in inside-out patches excised from the membrane of split-fiber blebs. Formation of these blebs was induced by mechanical cleavage of fibers dissected from the iliofibularis thigh muscle of adult frogs, *Rana esculenta* (Vivaudou et al., 1991).

Conditions were designed to optimize recording of K_{ATP} channels, which are present at high density in our preparation. The patch pipette contained 150 mM K^+ , 136 mM Cl^- , 2 mM Mg^{2+} , and 10 mM PIPES. The cytoplasmic face of the patch was bathed in solutions that all contained 150 mM K^+ , 40 mM Cl^- , 1 mM EGTA, 10 mM PIPES, and methanesulfonate⁻ as the remaining anions. No Mg^{2+} was added except where noted. In particular, for the experiments described in Fig. 5 and all subsequent figures, the solution containing 3 mM ATP had 5 mM Mg^{2+} , but other solutions contained no Mg^{2+} . The concentration of contaminant Mg^{2+} in nominally Mg^{2+} -free solutions was less than 10 μ M (Forestier and Vivaudou, 1993*a*). Solutions were titrated with KOH or HCl, and solution pHs were found to remain stable during the course of an experiment, even when outside the effective buffering range of PIPES (i.e., pH 5.8–7.8).

When not explicitly specified, pH was set to 7.1, and the membrane potential V_m was -50 mV. Experiments were conducted at room temperature (22–24°C). ATP (potassium salt) was purchased from Sigma Chemical Co. (St. Louis, MO). Levromakalim (code name BRL 38227; from SmithKline Beecham, Harlow, UK), SR 47063 (Sanofi Recherche, Montpellier, France), pinacidil, and aprikalim (code name RP 52891; Rhône-Poulenc Rorer, Vitry-sur-Seine, France) were added from stock solutions (respectively, 100 mM, 10 mM, 182 mM, and 20 mM) in DMSO. DMSO alone was without effects on K_{ATP} channel activity at all pHs used. Final concentrations of levromakalim and SR 47063 higher than 200 μ M yielded cloudy solutions, indicating solubility problems. To be safe, data points obtained at concentrations higher than 100 μ M were not used to build dose–response curves for these KCOs.

Application of the various solutions to the intracellular face of the patch was performed using a RSC-100 rapid solution changer (Bio-Logic, Claix, France) controlled by the custom software Perf 2.10 (M. Vivaudou, available upon request). Concentrations of free (i.e., not bound to Mg^{2+}) and bound nucleotides were estimated by using Al2 (M. Vivaudou, available upon request), which is the latest version of the software program Alex (Vivaudou et al., 1991). Values given in the text represent total concentrations unless expressly specified.

Analogue signals were filtered at 300 Hz and sampled at 1 kHz. For presentation, additional Gaussian filtering and undersampling were done numerically. Final cut-off and sampling frequencies are indicated in the figure captions as f_c and f_s , respectively. Slow fluctuations of the no-channel-open baseline of the current signal were removed by interactive fitting of the baseline with a spline curve and subtraction of this fit from the signal. Acquisition, analysis, and presentation were performed with the custom software Erwin 3.1 (M. Vivaudou, available upon request), fitting of dose–response data with Origin 3.7 (MicroCal, Northampton, MA), and mathematical modeling with MathCad 5.0 (MathSoft, Cambridge, MA) and Excel 5.0 (Microsoft Corp., Redmond, WA).

Mean patch current, I , was computed by averaging data samples over selected portions of the signal. Mean current is given by $I = NP_o i$, where i is the amplitude of the single-channel current, N is the number of active channels in the patch, and P_o is the channel-open probability. For short data stretches, the extent of rundown remained small and N could be safely taken as constant. Consequently, in conditions in which i stayed constant, mean current was used directly as a measure of channel activity proportional to P_o . However, single-channel current varies with pH (Vivaudou and Forestier, 1995). Therefore, in those experiments in which we needed to compare data at different pHs, we used the quantity $I \div i$ (i.e., NP_o) as an indicator proportional to P_o . Values of i at each pHs were experimentally determined, as described earlier (Vivaudou and Forestier, 1995).

Normalized KCO-induced activity was computed as the difference between mean current at a given KCO concentration, and control mean current divided by the difference between the maximum mean current and the control mean current. The maximum current was the current obtained in absence of ATP.

$$\text{Normalized KCO-induced Activity} = \frac{I(|ATP|, |KCO|) - I(|ATP|, |KCO| = 0)}{I(|ATP| = 0, |KCO| = 0) - I(|ATP|, |KCO| = 0)} \quad (1)$$

Nucleotide and proton dose-response curves were obtained and processed as in previous works (Vivaudou and Forestier, 1995). The following functions, designated as H_1 , H_2 , and H_3 , which are standard Hill functions for full agonists and antagonists, were used to quantify the effects of nucleotides, KCOs, and protons, respectively:

$$H_1(|Nucleotide|) = \frac{Max}{1 + \left[\frac{|Nucleotide|}{K_{1/2}} \right]^h}, \quad (2)$$

$$H_2(|KCO|) = \frac{Max \times |KCO|^h}{|K_{1/2}|^h + |KCO|^h}, \quad (3)$$

$$H_3(pH) = \frac{Max}{1 + 10^{x \cdot h \cdot (pH - pK)}}, \quad (4)$$

where h is the dimensionless Hill coefficient, $K_{1/2}$ is the concentration causing 50% inhibition or activation, and pK is the pH value causing 50% activation. Max is the maximum value, which should be 1 for normalized data. Eq. 4 was used to model activation of K_{ATP} channels ($x = 1$) as well as inhibition of KCO-induced current ($x = -1$) by protons.

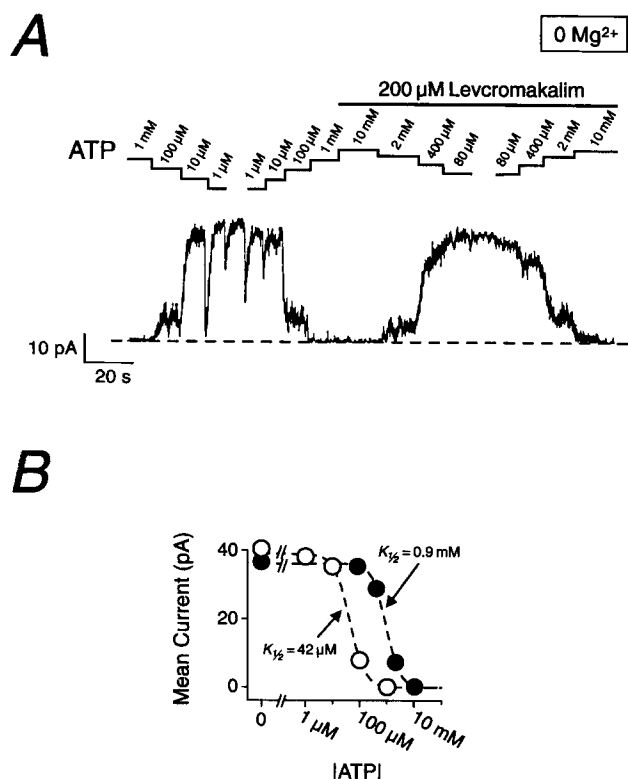

FIGURE 1. Levcromakalim reduces channel sensitivity to ATP inhibition. (A) Current response to ATP inhibition before and after application of a saturating dose of levcromakalim. Solutions contained no added Mg^{2+} . $f_s = 100$ Hz, $f_c = 30$ Hz; $V_m = +30$ mV; Patch 280703A. (B) Corresponding plots of the mean current at each concentration of ATP vs. ATP concentration without (open circles) and with (filled circles) levcromakalim. Dashed lines represent the best fits of the data points to Eq. 2 with values for $K_{1/2}$ and h of 42 μ M and 1.6 (control) and 900 μ M and 1.7 (levcromakalim).

Each observation discussed in this article was reproduced in at least three different patches. Results are displayed as the mean \pm SD.

RESULTS

Mutual Interaction between bKCOs and Nucleotides

We have already shown that SR 47063 and levcromakalim caused K_{ATP} channel activation in our preparation and that this effect was antagonized by protons (Forestier et al., 1993). We now examine in more detail how KCOs interact with nucleotides to produce activation.

Activation by bKCOs was seen only in the presence of

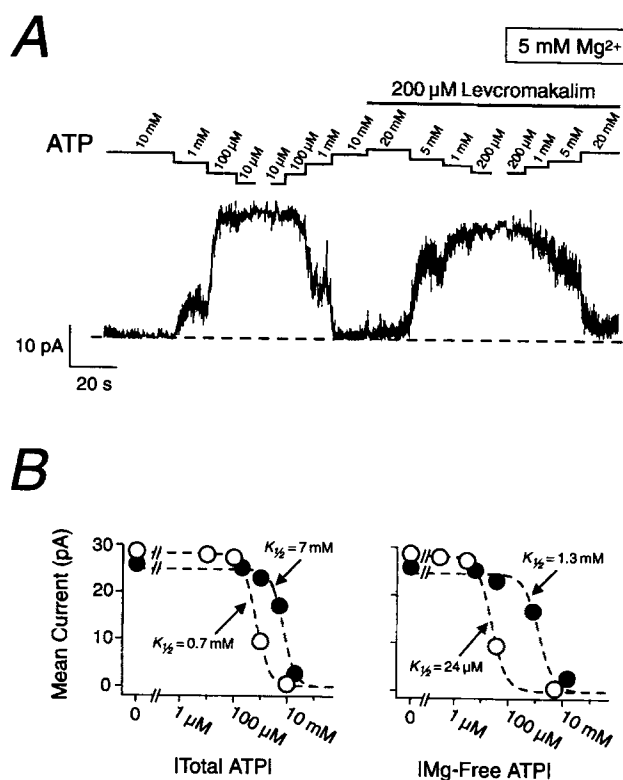

FIGURE 2. The effect of levcromakalim on channel sensitivity to ATP is independent of Mg^{2+} . (A) Current response to ATP inhibition before and after application of a saturating dose of levcromakalim. All solutions contained 5 mM Mg^{2+} . $f_s = 100$ Hz, $f_c = 30$ Hz; $V_m = +30$ mV; Patch 280703A. This trace was recorded right after the trace from the same patch shown in Fig. 1. (B) Corresponding plots of the mean current at each concentration of ATP vs. total ATP concentration (left) and computed Mg-free ATP (right) without (open circles) and with (filled circles) levcromakalim. Dashed lines represent the best fits of the data points to Eq. 2 with values for $K_{1/2}$ and h of 0.67 mM and 1.7 (control, total ATP), 7.2 mM and 1.9 (levcromakalim, total ATP), 24 μ M and 1.6 (control, Mg-free ATP), and 1.3 mM and 1.6 (levcromakalim, Mg-free ATP).

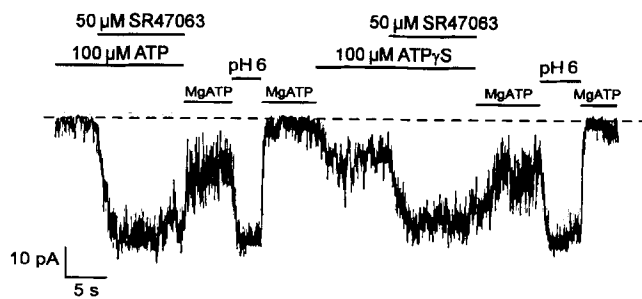

FIGURE 3. SR 47063 relieves channel inhibition by the ATP analogue ATP γ S. Channel activation was observed first in the presence of 100 μ M ATP and then, after washing out the KCO by application of an acidic solution (Forestier et al., 1993), in the presence of 100 μ M ATP γ S. The solution marked *MgATP* contained 3 mM ATP and 5 mM Mg $^{2+}$. Other solutions contained no Mg $^{2+}$. The pH was 7.1 throughout, except for the pH 6 nucleotide-free solution (marked *pH 6*), which served to accelerate recovery from KCO activation (Forestier et al., 1993). $f_s = 400$ Hz, $f_c = 100$ Hz; $V_m = -50$ mV; Patch 41M9.

inhibiting doses of ATP. At high-enough doses of ATP, channels stayed closed with or without KCOs. In the absence of ATP, bKCOs caused no activation even when channel activity was far from maximal because of run-down or other unknown factors.

These observations are simply explained by the finding that bKCOs decrease the affinity of the channel for

ATP as demonstrated by Fig. 1. With a near-maximal dose of activator, the affinity was decreased by more than one order of magnitude. This effect was not contingent on the presence of Mg $^{2+}$, as it was observed without (Fig. 1) and with mM Mg $^{2+}$ (Fig. 2).

As we have already reported (Vivaudou et al., 1991; Forestier and Vivaudou, 1993*a*), the addition of mM Mg $^{2+}$ causes a large decrease in the inhibitory potency of ATP or ADP. This was clearly seen in the patch used in Figs. 1 and 2, where the ATP concentration for half-maximal inhibition in control conditions changed from 40 μ M (Fig. 1 *B*) to 700 μ M (Fig. 2 *B, left*) on addition of 5 mM Mg $^{2+}$. This presumably reflects the lower sensitivity of the channel to block by Mg $^{2+}$ -bound nucleotides. Fig. 2 *B (right)* shows a plot of channel activity versus the concentration of the Mg-free forms of ATP (mainly ATP $^{4-}$, ATPH $^{3-}$, and ATPK $^{3-}$). If block by Mg-ATP was weak enough, the relationship between channel activity and Mg-free ATP should remain the same in the presence or absence of Mg $^{2+}$. Within the precision of our analysis, this prediction matched our observations, as in the examples of Figs. 1 and 2 where the half-inhibitory concentration of Mg-free ATP stayed near 33 μ M in 0 Mg $^{2+}$ and in 5 mM Mg $^{2+}$. This concentration was raised by levcromakalim to ~ 1 mM in both conditions, suggesting that, first, bKCOs interact with the binding site for Mg-free ATP, and second, activation by bKCOs is not regulated by Mg $^{2+}$ or MgATP $^{2-}$ ions. It is

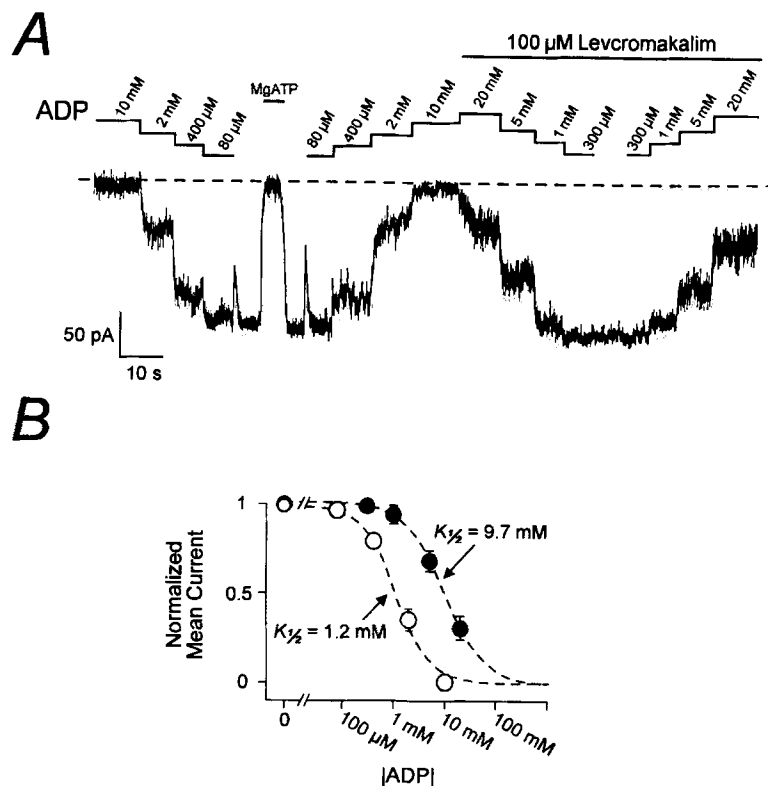

FIGURE 4. Levcromakalim reduces channel sensitivity to ADP inhibition. (A) Current response to ADP inhibition before and after application of a saturating dose of levcromakalim. The solution marked *MgATP* contained 3 mM ATP and 5 mM Mg $^{2+}$. Other solutions contained no ATP and no Mg $^{2+}$. $f_s = 200$ Hz, $f_c = 100$ Hz; $V_m = -50$ mV; Patch 33M3. (B) Corresponding plots of the mean current normalized to the 0 ADP current at each concentration of ADP vs. ADP concentration without (*open circles*) and with (*filled circles*). Each symbol and bar represent the average and standard deviation of eight measurements obtained by repeating the perfusion protocol of A with either $V_m = -50$ mV or $V_m = +30$ mV. (No obvious effects of V_m on ADP sensitivity were noticed.) Dashed lines represent the best fits of the data points to Eq. 2 with values for $K_{1/2}$ and h of 1.2 mM and 1.3 (control) and 9.7 mM and 1.1 (levcromakalim).

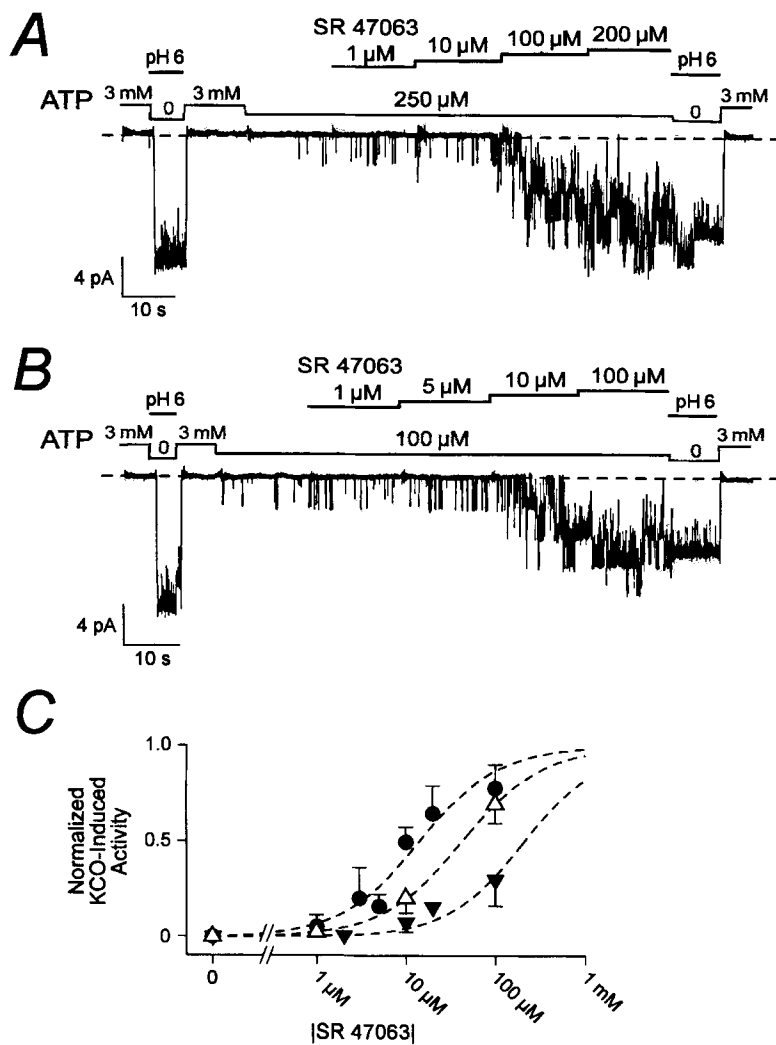

FIGURE 5. ATP reduces apparent channel affinity for SR 47063. (*A* and *B*) Channel activity induced by increasing doses of SR 47063 recorded successively in the presence of 250 μM and 100 μM ATP. Except for the 0 ATP, pH 6 solution, pH was 7.1. This pH 6 solution was used routinely to reverse KCO activation (see text), thus permitting a rapid return to control conditions for subsequent tests in the same patch. $f_s = 200$ Hz, $f_c = 60$ Hz; $V_m = -50$ mV; Patch 411405. (*C*) Mean responses to SR 47063 in the presence of 100 μM ATP (filled circles), 250 μM ATP (open triangles), and 500 μM ATP (filled triangles) compiled from the responses of 18 patches. Each symbol and bar represent the average and standard deviation of 3 to 10 measurements obtained using the protocols and solutions of *A* and *B*. Dashed lines are best fits of the data points to Eq. 3 with values for $K_{1/2}$ and h of 14 μM and 0.98 (100 μM ATP), 42 μM and 0.96 (250 μM ATP), and 210 μM and 1.0 (500 μM ATP).

therefore unlikely that bKCO activation involves a phosphorylation step. This is further supported by our observation that bKCOs are able to reverse inhibition by the poorly hydrolyzable ATP analogue ATP γ S (Fig. 3) as well as by ADP (Fig. 4).

The reduction in nucleotide affinity by bKCOs suggests a competitive interaction between the nucleotide binding sites and the bKCO binding sites. Such an interaction would predict that, reciprocally, nucleotides would affect channel affinity for bKCOs. Indeed, the concentration of bKCO necessary for half-maximal activation increased as the concentration of ATP increased. This is illustrated in Fig. 5 for SR 47063. At all ATP concentrations, SR 47063 activation followed a simple Langmuir adsorption isotherm. Hill coefficients remained close to 1, whereas the dissociation constant increased approximately fourfold for a twofold increase in ATP. Similar results were obtained with levcromakalim, which has about half the potency of SR 470563.

Activation by KCOs Is Antagonized by Protons

The effects of protons on activation by pinacidil and aprikalim (Figs. 6 and 7) were tested with the same type of protocols used earlier (Forestier et al., 1993) for the benzopyran KCOs, levcromakalim and SR 47063. Overall, results were similar for all four KCOs despite differences in structure, potency, and dissociation rate.

Fig. 6 *A* shows that pinacidil activation is antagonized by protons. At pH 7.1 channel activity is strongly increased by a near-maximal dose of pinacidil but reverts to its control value (i.e., activity at pH 6 without KCO) when pH is lowered to 6. Fig. 6 *B* further demonstrates that protons enhance the dissociation rate of pinacidil from the channel, which is consistent with a decrease in affinity. At pH 7.1, a short application of pinacidil in 0 ATP has no apparent immediate effect on channel activity, but subsequent application of a blocking concentration of ATP uncovers a persistent increase in channel activity that we interpret as the slow dissociation of the activator from its binding site. A brief acidification

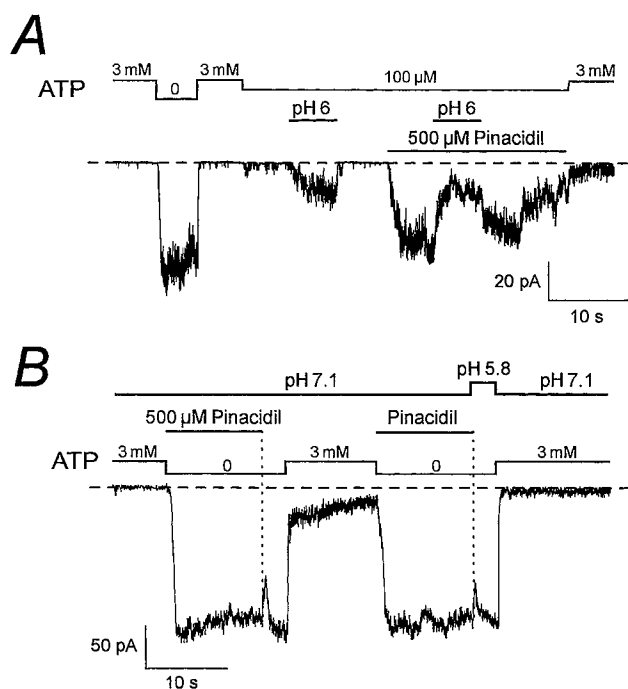

FIGURE 6. Protons block the activatory effect of pinacidil. (A) Lowering pH from 7.1 to 6 reverses activation by pinacidil (500 μ M). Except where marked, pH was 7.1. $f_s = 500$ Hz, $f_c = 200$ Hz; $V_m = -50$ mV; Patch 370804. (B) A brief acidification from pH 7.1 to 5.8 eliminates the persistent activation remaining after application of pinacidil (500 μ M). $f_s = 330$ Hz, $f_c = 100$ Hz; $V_m = -50$ mV; Patch 363004.

to approximately pH 6 suppresses this persistent activity, i.e., protons accelerate the dissociation of the activator. Such a protocol has the merit of excluding “artefactual” interactions between KCO, ATP, and protons as a source of the observation, since these effectors are applied sequentially and therefore never meet in the same solution (although one cannot exclude some mixing between successive solutions when switching perfusion outlets). Similar protocols were used with aprikalim with essentially the same results (Fig. 7). At pH 7.1, aprikalim was found to dissociate faster than pinacidil and benzopyran KCOs, as shown by the more rapid decay of the current after aprikalim application (Fig. 7 B). Nonetheless, the acceleration of dissociation remained unambiguous and very reproducible in spite of the smaller signal size. It therefore appears that acidic pH has the same effect on all tested KCOs, suggesting that KCOs have a common mechanism of action, if not a common site of action, despite an apparent lack of structural homology.

The effect of protons on KCO activation was characterized more quantitatively by examining its dose dependence. This was done with the two benzopyran KCOs, levromakalim and SR 47063, by conducting experiments illustrated in Figs. 8 A and 9 A. In those ex-

periments, the relationship between pH and channel activity was obtained with and without bKCOs. In the control, activity steeply augments as pH decreases. With 100 μ M internal ATP, the pK of this activation approaches 6 (Vivaudou and Forestier, 1995). In the presence of a saturating concentration of KCO, activity is strongly potentiated at basic pHs compared with the control. As pH is lowered, activity first decreases until pH 6, then goes up again at pH below 6. This behavior is peculiar but not unexpected, considering what we know about protons and skeletal muscle K_{ATP} channels. On one hand, we have shown qualitatively that, in the presence of KCOs, lowering pH reduces channel activity via removal of KCO activation and that this effect appears nearly complete at pH 6 (Figs. 6 and 7, and Forestier et al., 1993). On the other hand, lowering pH augments channel-open probability with a pK of 6 in the presence of 100 μ M ATP (Vivaudou and Forestier, 1995). Because the pH ranges of these two opposite actions do not fully overlap, the inhibitory effect of protons predominates at pH >6 , whereas at pH <6 one observes only the activatory effect.

Considering only the pH dependence of the KCO-induced activity (Figs. 8 C and 9 C), one finds a pK of 6.6 for both KCOs tested. This dependence is rather steep, with a Hill coefficient of 2.5. Although this latter parameter has no special significance in terms of a model, its value greater than 1 suggests that more than one protonation site is involved.

K_{ATP} Channel Modulation by Nucleotides, Protons, and KCOs: A Reactional Model

Our previous observations on the competitive effects of protons and nucleotides on the K_{ATP} channel led us to postulate a model in which the channel open configuration was stabilized by protons (four concerted sites) and the closed configuration was stabilized by nucleotides (two concerted sites) (Vivaudou and Forestier, 1995). This simple model was found to adequately predict all our results. Taking this model as a starting point, we have tried to build a more elaborate model integrating bKCO effects that could account for our previous and our present observations. The most difficult behavior to reproduce was the complex pH dependence of channel activity in the presence of bKCOs responsible for the unusual shape of the dose-response curves of Figs. 8 C and 9 C. We have tested a number of schemes of various complexity and found only one capable of producing such responses.

This scheme is outlined in Fig. 10 A. Intuitively, one sees that this scheme predicts competitive interactions between ATP and protons and between bKCOs and protons, as found experimentally. It also predicts activation by protons in the absence of KCOs as well as inhibition in their presence. This inhibition results from

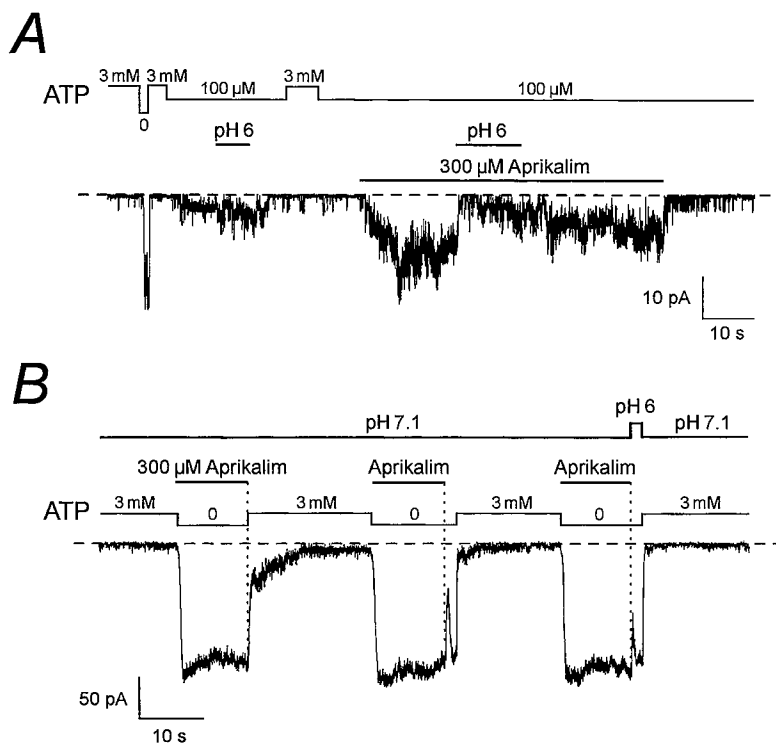

FIGURE 7. Aprikalim, like pinacidil and benzopyran KCOs, loses potency at acidic pH. (A) Lowering pH from 7.1 to 6 reverses activation by aprikalim (300 μ M). Except where marked, pH was 7.1. $f_s = 500$ Hz, $f_c = 200$ Hz; $V_m = -50$ mV; Patch 370703. (B) A brief acidification from pH 7.1 to 6 enhances the wash-out of the activation remaining after application of aprikalim (300 μ M). $f_s = 330$ Hz, $f_c = 100$ Hz; $V_m = -50$ mV; Patch 370701.

sequential protonation sites: The first protonations remove bKCO sensitivity while preserving ATP sensitivity, thus causing a reduction in channel activity at intermediate pHs in the presence of ATP. The last protona-

tions make the channel insensitive to block by ATP as well, thus causing an increase in activity at low pHs.

In its general form, this scheme assumes that the channel possesses four classes of identical sequential

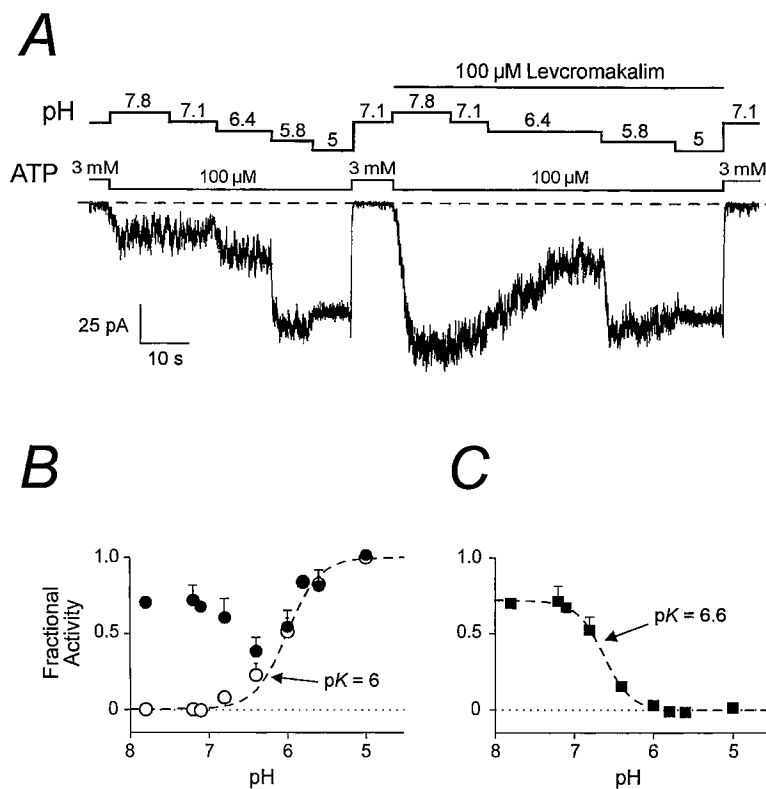

FIGURE 8. pH dependence of K_{ATP} channel activity induced by levcromakalim. (A) Currents recorded at progressively lower pHs in the presence of 100 μ M ATP in control conditions and in the presence of 100 μ M levcromakalim. $f_s = 100$ Hz, $f_c = 30$ Hz; Patch 39M4. (B) Plot of fractional channel activity in 100 μ M ATP vs. pH in the absence (open circles) and presence (filled circles) of 100 μ M levcromakalim compiled from data obtained in four patches using the protocol of A. Activity was obtained by measuring mean current and correcting it to account for the reduction of single-channel current by protons (see Methods). It is expressed here as a fraction relative to the control value at pH above 7 and normalized to the maximum value at the lowest pH in the absence of KCO. The dashed line represents the expected relationship between activity and pH in 100 μ M ATP, it is the best fit of all our experimental data (17 patches) to Eq. 4 with $pK = 6.0$ and $h = 2.1$. (C) Plot of levcromakalim-induced activity vs. pH computed by subtraction (see Methods) from the same data set as B. The dashed line represents the best fit of the data points to Eq. 4 with $pK = 6.62$ and $h = 2.50$.

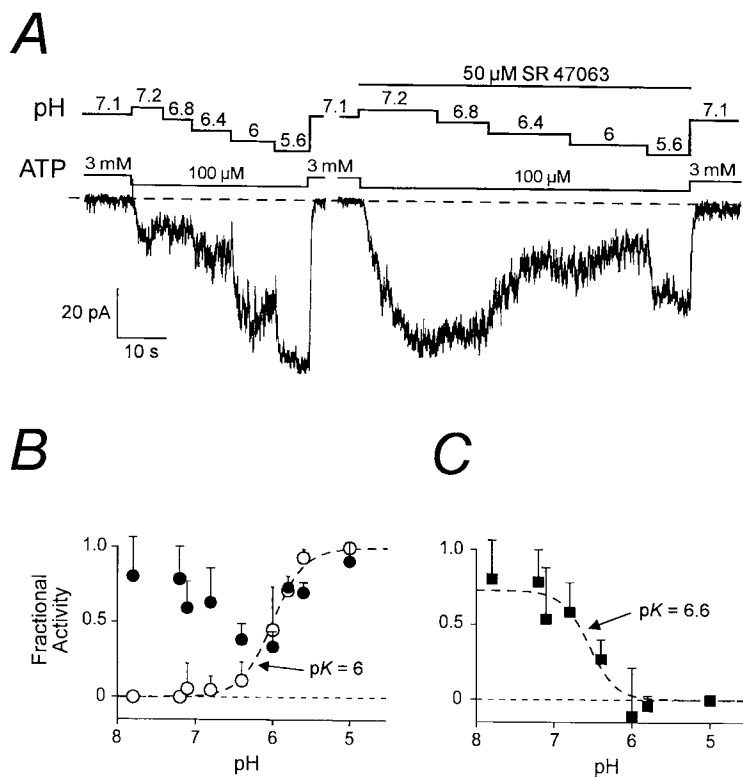

FIGURE 9. pH dependence of K_{ATP} channel activity induced by SR 47063. (A) Currents recorded at different pHs in the presence of 100 μ M ATP without and with 50 μ M SR 47063. $f_s = 110$ Hz, $f_c = 50$ Hz; Patch 320902. (B) Plot of fractional activity in 100 μ M ATP vs. pH in the absence (open circles) and presence (filled circles) of 50 μ M SR 47063 (9 patches). Dashed line as in Fig. 8. (C) Plot of SR 47063-induced activity vs. pH. The dashed line represents the best fit of the data points to Eq. 4 with $pK = 6.55$ and $h = 2.50$.

sites that stabilize the channel in a given conformation: n_{ATP} nucleotide sites of affinity K_{ATP} linked to a closed state, n_{KCO} opener sites of affinity K_{KCO} linked to an open state, and two classes of protonation sites that we shall call class I and class II. When occupied, class I sites (n_{IH} sites of affinity K_{IH}) secure the channel in a configuration accessible to nucleotides but not KCOs. Subsequent occupation of class II sites (n_{2H} sites of affinity K_{2H}) stabilizes an open configuration inaccessible to nucleotides. Predicted channel-open probability may be expressed relatively easily as a function of the above eight variable parameters (Monod et al., 1965; Vivaudou and Forestier, 1995). Model predictions could thus be compared with the experimental data. Predicted and experimental curves were superposed and parameters were adjusted until the best match, as judged by eye, was achieved. This process indicated that the data left little choice for the stoichiometry of the model and led to a model of the form shown in Fig. 10 B. With a single pK of 6.6 for all protonation sites and dissociation constants of 0.7 μ M for the opener SR 47063 and ~ 35 μ M for ATP, the model accurately predicted the four different sets of experimental data for which we had enough statistical evidence (Fig. 11): channel inhibition by ATP at different pHs (Fig. 11 A), channel activation by protons at different ATP concentrations (Fig. 11 B), channel activation by the opener SR 47063 at different ATP concentrations (Fig. 11 C), and relief

of SR 47063 activation by protons (Fig. 11 D). For optimal fit, the parameter K_{ATP} was slightly varied for each set of data to account for the inherent variability of the ATP sensitivity of K_{ATP} channels that we and others (Findlay and Faivre, 1991) have observed.

DISCUSSION

In a preceding paper, we examined the mechanism of the activation of skeletal muscle K_{ATP} channels by protons (Vivaudou and Forestier, 1995). The same approach was used here to study the mechanism of action of synthetic activators on these channels.

Role of Nucleotides in the Activation of Skeletal Muscle K_{ATP} Channels by Pharmacological Openers

In cardiac muscle, where this has been studied most extensively, it now appears well established that the primary effect of KCOs is to reduce the ability of ATP to block K_{ATP} channels. This was first demonstrated by Thuringer and Escande (1989) for the thioformamide RP 49356 in one of the first detailed studies of the mechanism of action of an opener. Ripoll et al. (1990) and Terzic et al. (1994a) later reported similar decreases in ATP affinity by the benzopyran derivatives cromakalim and HOE-234, respectively. These observations suggest a competitive mechanism, and indeed, Thuringer and Escande (1989) further observed that the interaction

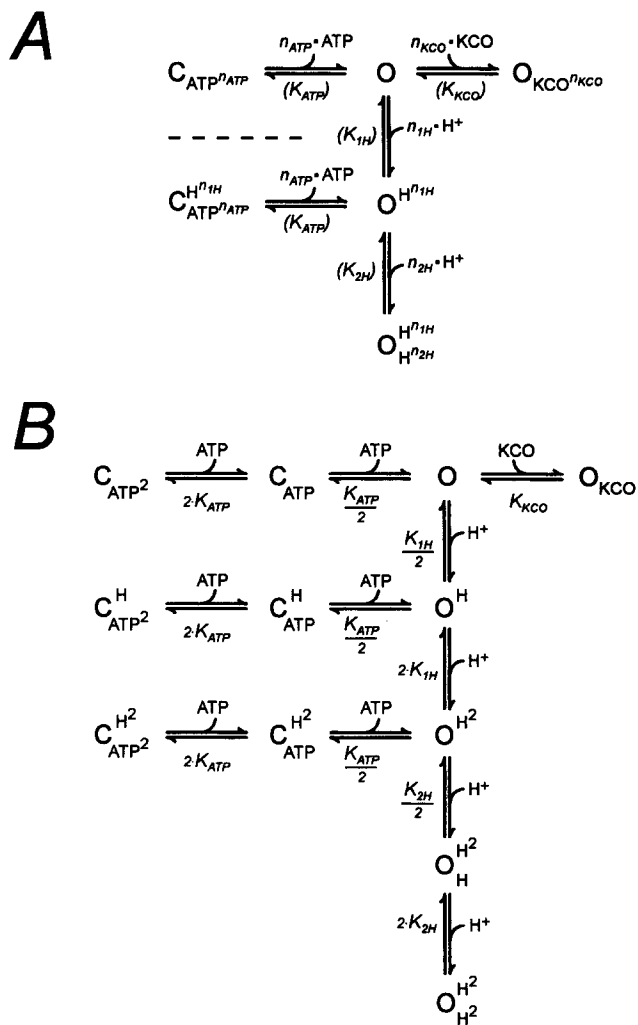

FIGURE 10. Reactional scheme considered to explain the stationary effects of protons, nucleotides, and KCOs on the open probability of the K_{ATP} channel. The symbols O and C refer to the channel being open and closed, respectively. (A) General scheme. The numbers n_x refer to the number of identical independent sites accessible to ligand x . The microscopic dissociation constants K_x of each type of sites are indicated in parentheses. (B) Implementation of the general scheme with $n_{ATP} = n_{1H} = n_{2H} = 2$ and $n_{KCO} = 1$ yielding the best prediction of the experimental data. The apparent dissociation constants for each successive binding step are indicated below the reaction arrows as a function of the microscopic constants. The best-fit values of the microscopic constants are given in Fig. 11.

ATP-opener was reciprocal: Whereas RP 49356 decreased the ATP sensitivity of cardiac K_{ATP} channels, ATP decreased the activatory potency of the opener. Such ATP dependence of KCO-induced current was also reported for pinacidil (Fan et al., 1990) and nicorandil (Nakayama et al., 1991).

In skeletal muscle, we also find an apparent competition between the benzopyran openers, levcromakalim and SR 47063, and ATP based on the evidence that

bKCOs decrease ATP affinity and that ATP decreases bKCO affinity. We further show that bKCOs have the same effect on ATP and ADP. This latter observation is consistent with the hypothesis that nucleotides share common inhibitory sites on the channel (Vivaudou et al., 1991; Vivaudou and Forestier, 1995) and that KCOs are linked to these sites.

It is therefore clear, at least in cardiac and skeletal muscle, that one characteristic common to all KCOs studied is their ability to reduce inhibition by ATP. It appears that this is not the only effect of KCOs because KCOs have the ability to affect K_{ATP} channels in the absence of nucleotides, to reactivate channels after rundown, or both. The nature of these additional effects is probably complex because they have not been observed consistently, even under similar experimental conditions. For instance, in cardiomyocytes, RP 49356 or its enantiomer, aprikalim, caused activation in nucleotide-free conditions in certain cases (Escande et al., 1989; Thuringer and Escande, 1989) but were ineffective in others (Ripoll et al., 1990; Thuringer et al., 1995). In heart muscle, experiments with benzopyran KCOs such as cromakalim, SR 44866, or HOE-234 have also yielded conflicting results (Escande et al., 1989; Findlay et al., 1989; Ripoll et al., 1990; Shen et al., 1991; Terzic et al., 1994).

In amphibian skeletal muscle, none of the openers that we tested, levcromakalim, SR 47063, pinacidil, and aprikalim, had any effect in the absence of nucleotides before or after rundown. More generally, we have no evidence for time- or rundown-dependent changes of any of the responses we describe. Comparison with the other studies on KCOs and skeletal muscle, which all concerned mammalian muscle, is difficult because of contradictory findings regarding KCO effectiveness or ineffectiveness on ATP-free or rundown channel activity: Ineffectiveness in mouse muscle for pinacidil and cromakalim (Weik and Neumcke, 1990; Allard and Lazdunski, 1992), but effectiveness also in mouse muscle for levcromakalim (Hussain et al., 1994) and RP 49356 (Weik and Neumcke, 1990) as well as in human muscle for cromakalim and RP 49356 (Quasthoff et al., 1990). It therefore seems premature to conclude that amphibian and mammalian K_{ATP} channels have distinct properties, especially when one sees that opposite effects of the same KCO (levcromakalim) have been recorded in the same species (mouse). It could well be that discrepancies arise from unidentified differences in experimental conditions that will have to be resolved before further discussion.

The above results suggest that, in frog skeletal muscle, the activation of K_{ATP} channels by KCOs could be due solely to competitive relief of inhibition by nucleotides. The case for this conclusion is stronger for the benzopyrans, levcromakalim, and SR 47063, for which

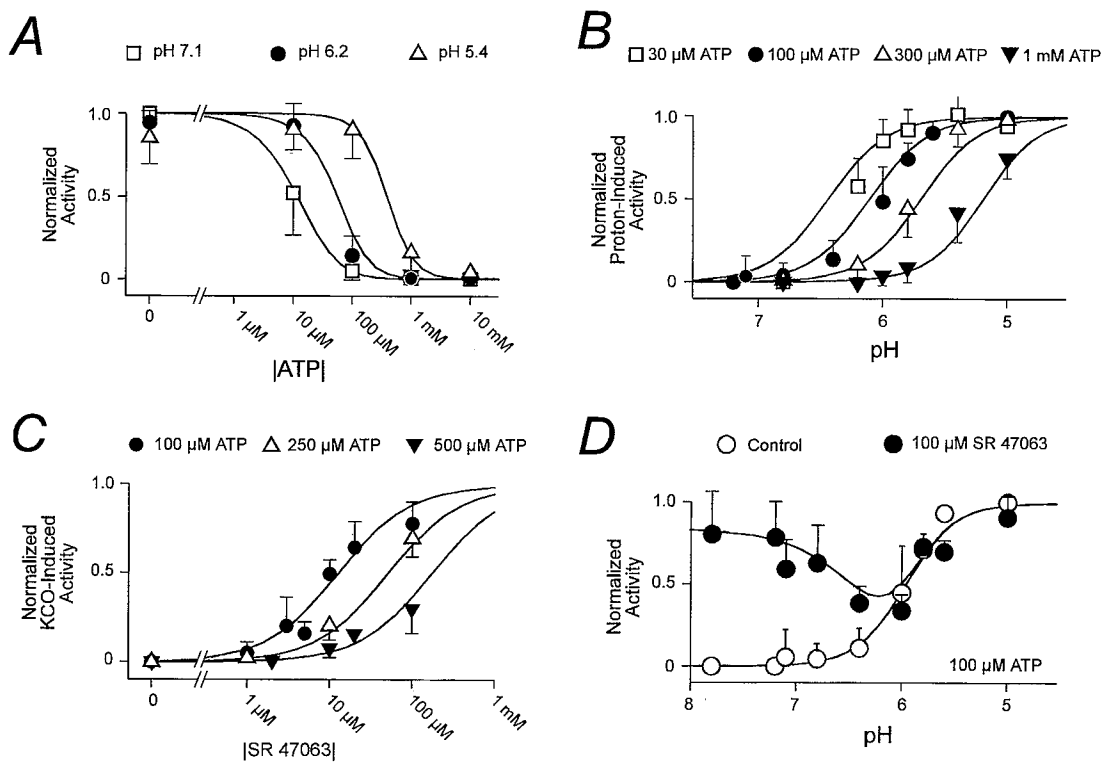

FIGURE 11. Model predictions match all experimental observations on the regulation of K_{ATP} channels by ATP, protons, and SR47063. Symbols represent experimental points and solid lines represent predictions of the model of Fig. 10 B with $pK_{1H} = pK_{2H} = 6.62$, $K_{KCO} = 0.7 \mu\text{M}$, and K_{ATP} between 24 and 46 μM . The actual value of K_{ATP} , adjusted for each dose–response plot to improve the fit, is given below. (A) pH dependence of ATP inhibition. Experimental points are redrawn from Vivaudou and Forestier (1995). $K_{ATP} = 24 \mu\text{M}$. (B) ATP dependence of proton activation. Experimental points are redrawn from Vivaudou and Forestier (1995). $K_{ATP} = 38 \mu\text{M}$. (C) ATP dependence of SR 47063 activation. Experimental points are redrawn from Fig. 5 B. $K_{ATP} = 46 \mu\text{M}$. (D) Effects of protons in the presence of SR 47063. Experimental points are redrawn from Fig. 9 B. $K_{ATP} = 24 \mu\text{M}$.

the experimental evidence is more extensive, but we have no experimental data indicating that pinacidil and aprikalim behave differently.

One feature of our observations that led to this conclusion is that nucleotides are necessary to visualize the effects of KCOs. This requirement for nucleotides does not appear to apply to the binding of KCOs to their target, as it would, for example, if binding site accessibility was dependent on phosphorylation or some other complex process as hypothesized for certain KCOs in several studies (Dunne et al., 1990; Shen et al., 1991; Hehl and Neumcke, 1994; Hussain et al., 1994).

In our hands, no qualitative differences in KCO activation were noticed when experiments were conducted in ADP rather than ATP, in the presence of Mg^{2+} rather than in its virtual absence, and when channels were blocked by the ATP analogue ATP γ S. Moreover, the simple experiments depicted in Fig. 6 B for pinacidil and Fig. 7 B for aprikalim and in a previous report (Forestier et al., 1993) for levcromakalim and SR 47063 demonstrate that these KCOs are able to bind to their targets in the absence of nucleotide and Mg^{2+} , even though in those conditions they have no apparent ef-

fects on K_{ATP} channel open probability. One implication of this result is that models, such as that from Hehl and Neumcke (1994), in which KCOs (in that case, pinacidil) may only bind to the channel when a site for Mg-complexed nucleotides is occupied, would have to be revised. We therefore see no absolute requirement for Mg-complexed nucleotides for initiation of KCO action in amphibian skeletal muscle, although we have not investigated this in detail, and would therefore not rule out a potential modulation of KCO action by nucleotides. In particular, it appears that nucleotide diphosphates regulate activation by KCOs of cardiac K_{ATP} channels in a complex, Mg^{2+} -dependent manner (reviewed by Terzic et al., 1995). Our model, which was built only using results obtained in the absence of Mg^{2+} , would not account for such regulations.

Protons Antagonize the Action of Benzopyran and Non-benzopyran Openers

We recently discovered that protons, in addition to their strong agonist action on skeletal muscle K_{ATP} channels (Davies, 1990), could have antagonistic effects in the

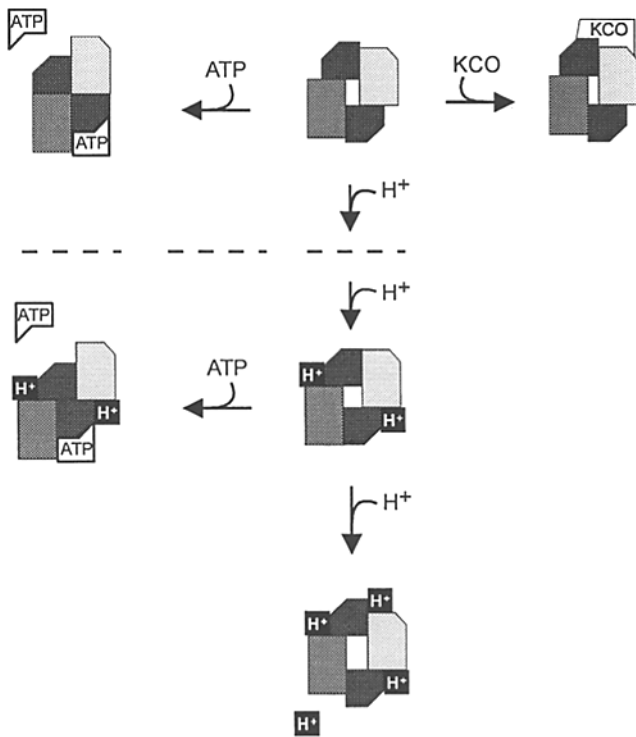

FIGURE 12. A hypothetical structural model of a tetrameric K_{ATP} channel. This model, severely constrained by its two-dimensional representation, would conform to the steady-state reaction scheme of Fig. 10 B. The channel complex would possess one KCO site stabilizing an open conformation, two concerted ATP binding sites stabilizing a closed conformation, two concerted protonation sites stabilizing a conformation having a low affinity for KCOs, and two subsequent concerted protonation sites stabilizing an open conformation. Channel subunits would be allosterically linked so that subunit motion would be constrained to maintaining the channel axial symmetry.

presence of benzopyran KCOs (Forestier et al., 1993). Our experimental evidence revealed that this peculiar behavior arose from a proton-induced reduction in the activatory effect of bKCOs that could not be attributed to protonation of the KCOs themselves, as they have no titratable sites. This reduction was at least in part caused by a drastic acceleration of the dissociation of the bKCOs on protonation, suggesting that protonation affected affinity rather than efficacy. As the details of this proton-KCO interaction constitute a sort of fuzzy signature of the KCO binding site, one aspect of the present work was to examine whether this signature might differ with KCOs of distinct structures as it would if they bound to different sites. We tested aprikalim, a thioformamide, and pinacidil, a cyanoguanidine (Gopalakrishnan et al., 1993). These KCOs are less potent than SR 47063 and levromakalim at activating skeletal muscle K_{ATP} channels, as nearly maximal activation (with 100 μ M internal ATP) requires 100 μ M SR 47063

but 300 to 500 μ M aprikalim or pinacidil. One reason for this lower affinity could be their greater dissociation rate, exemplified by the more rapid return to normal channel activity after a brief application of KCO (Figs. 6 and 7). In spite of these differences, protons were found to have the same effect on pinacidil and aprikalim as on levromakalim and SR 47063. Lowering pH from 7.1 to 6 completely canceled the KCO-induced current and sped up KCO dissociation so that recovery became too fast to be resolved under our recording conditions. On the basis of these similarities, we therefore see more evidence for common KCO binding sites than against. The existence of sites common to such chemically unrelated compounds would be puzzling, however, and one possibility could be that accessory molecules—proteins or lipids—would serve as intermediaries between channels and KCOs. Such a possibility could explain that binding of a pinacidil analogue, P1075, could be detected in intact but not in dispersed smooth muscle membranes (Quast et al., 1993).

So far, the role of intracellular protons in modulating KCO action has been the subject of few other studies, all in heart muscle. Venkatesh et al. (1992) did not see any effect of pH 6.5 on cromakalim effect in cardiac myocytes. Similarly, Jahangir et al. (1994) observed no effects of intracellular acidification to pH 6.5 on either control or pinacidil-induced whole-cell current in ventricular myocytes. Although these observations should be repeated at lower pH values, they confirm that cardiac K_{ATP} channels are much less sensitive to pH than skeletal muscle channels. If the agonistic effects of protons on nucleotide-inhibited activity is coupled to their antagonistic effects on KCO-induced activity, it would be normal that the weaker agonistic effects in heart muscle (e.g., Lederer and Nichols, 1989) be accompanied by weaker antagonistic effects. In fact, we see that, in the reactional model of Fig. 10, both effects are indeed coupled with the same protonation sites mediating both effects.

An Allosteric Model of the Skeletal Muscle K_{ATP} Channel: Structural Implications

Although several models of the K_{ATP} channel have been presented in the literature, most of these remained qualitative (e.g., Lederer and Nichols, 1989; Hehl and Neumcke, 1994; Terzic et al., 1994b) and therefore untested in terms of predictive value. Few attempts have been made to build more quantitative models. This was done by Nichols et al. (1991) for the ATP dependence of cardiac K_{ATP} channels and by us (Vivaudou and Forestier, 1995) for the ATP and pH regulation of skeletal muscle channels. Based on additional experimental data regarding the action of bKCOs, we are now able to present a more complete model that is capable of predicting rather accurately the isolated and combined ac-

tions of nucleotides, protons, and bKCOs. This model, as represented by the scheme of Fig. 10, seeks to explain our stationary experimental data and does not deal with kinetics, for which we do not have sufficiently accurate data. We therefore considered only equilibrium dissociation constants and not rate constants. This also implies that configurations of the channel not shown in the reactional scheme may exist but were not represented, as they were redundant. For example, the configuration of the channel with both KCO and protons bound is not represented, although it is likely to exist because we did observe experimentally that protons accelerated the dissociation of the KCOs from the channel.

Often complex interactions are explained in terms of physical coupling between sites, whereby the binding of one ligand affects the affinity of other ligands for their sites (e.g., Lederer and Nichols, 1989; Hehl and Neumcke, 1994; Terzic et al., 1994b). This type of mechanism is difficult to formulate chemically and might be unnecessarily complicated as demonstrated by the capacity of our scheme to predict the rather intricate regulation of the K_{ATP} channel. Our model features identical sites with fixed affinity. It does not postulate ligand-binding induced conformational changes, but it assumes spontaneous conformational changes of the channel and stabilization of the different conformation by ligand binding. Cooperativity arises therefore from the passive association of multiple sites to a specific conformation and not from active links between sites.

Considering the probable multimeric nature of the channel, one may imagine a structural model where distinct sets of sites might be uncovered by a concerted motion of subunits (Fig. 12). In this hypothetical physical model, the channel is assumed to be tetrameric, a structure adopted by other voltage-dependent K^+ channels (Mackinnon, 1991) as well as inward rectifier K^+ channels (Glowatzki et al., 1995). This tetrameric struc-

ture fits well our finding of four protonation sites. However, because we find two nucleotide binding sites and two pairs of protonation sites, the channel would need to be a heterotetramer. Such an arrangement is indeed supported by recent evidence suggesting that inward rectifier K^+ channels are made up of distinct protein subunits (Krapivinsky et al., 1995). We assume that despite their heterogeneity, subunits are constrained to move together to maintain overall axial symmetry as appears to be the case for other allosteric proteins (e.g., Monod et al., 1965; Goulding et al., 1994; Unwin, 1995). This motion may bring them into one of the six configurations shown which correspond to the chemical states of the scheme of Fig. 10. As discussed above, additional intermediary configurations, such as a KCO-bound, proton-bound state, may exist, since the reactional model makes no assumptions on whether ligands might or might not share the same sites. Nucleotides, KCOs, and protons are so dissimilar that it appears unlikely that they would occupy identical sites. Moreover, the presence of common sites would be in disagreement with the different stoichiometries that we obtained for these effectors.

The major merit of our allosteric model is that it demonstrates that a rather simple design can give rise to very intricate responses. Its major limit is that it is based only on functional data because of the lack of structural information on K_{ATP} channels. These channels still resist cloning in spite of recent claims (Ashford et al., 1994) which have been challenged by later studies (Krapivinsky et al., 1995; Duprat et al., 1995). However, with the recent cloning and sequencing of a sulfonylurea receptor (Aguilar-Bryan et al., 1995), structural data will no doubt be forthcoming and, when coupled with existing functional models as presented here, should provide a clearer view of how K_{ATP} channels actually work.

We thank Dr. I. Cavero (Rhône-Poulenc Rorer, Vitry-sur-Seine, France) for kindly supplying aprikalim, Dr. J.M. Evans (SmithKline Beecham Pharmaceuticals, Harlow, UK) for levromakalim, Dr. P. Gautier (Sanofi Recherche, Montpellier, France) for SR 47063, and Dr. S. Quasthoff (Münich, Germany) for pincidil.

This work was supported by Commissariat à l'Energie Atomique and Centre National de la Recherche Scientifique.

Original version received 23 October 1995 and accepted version received 8 December 1995.

REFERENCES

- Aguilar-Bryan, L., C.G. Nichols, S.W. Wechsler, J.P. Clement, A.E. Boyd, G. Gonzalez, H. Herrerasosa, K. Nguy, J. Bryan, and D.A. Nelson. 1995. Cloning of the beta cell high-affinity sulfonylurea receptor: A regulator of insulin secretion. *Science (Wash. DC)*. 268: 423-426.
- Allard, B., and M. Lazdunski. 1992. Nucleotide diphosphates activate the ATP-sensitive potassium channel in mouse skeletal muscle. *Pflüg. Arch.* 422:185-192.
- Ashcroft, S.J.H., and F.M. Ashcroft. 1990. Properties and functions of ATP-sensitive K-channels. *Cell. Signalling*. 2:197-214.

- Ashford, M.L.J., C.T. Bond, T.A. Blair, and J.P. Adelman. 1994. Cloning and functional expression of a rat heart K-ATP channel. *Nature (Lond.)* 370:456–459.
- Castle, N.A., and D.G. Haylett. 1987. Effect of channel blockers on potassium efflux from metabolically exhausted frog skeletal muscle. *J. Physiol.* 383:31–43.
- Coetzee, W.A. 1992. ATP-sensitive potassium channels and myocardial ischemia—why do they open. *Cardiovasc. Drugs Ther.* 6:201–208.
- Davies, N.W. 1990. Modulation of ATP-sensitive K⁺ channels in skeletal muscle by intracellular protons. *Nature (Lond.)* 343:375–377.
- Davies, N.W., N.B. Standen, and P.R. Stanfield. 1992. The effect of intracellular pH on ATP-dependent potassium channels of frog skeletal muscle. *J. Physiol.* 445:549–568.
- Dunne, M.J., R.J. Aspinall, and O.H. Petersen. 1990. The effects of cromakalim on ATP-sensitive potassium channels in insulin-secreting cells. *Br. J. Clin. Pharmacol.* 99:169–175.
- Duprat, F., F. Lesage, E. Guillemare, M. Fink, J.P. Hugnot, J. Bigay, M. Lazdunski, G. Romey, and J. Barhanin. 1995. Heterologous multimeric assembly is essential for K⁺ channel activity of neuronal and cardiac G-protein-activated inward rectifiers. *Biochem. Biophys. Res. Commun.* 212:657–663.
- Escande, D., D. Thuringer, S. Le Guern, J. Courteix, M. Laville, and I. Caverro. 1989. Potassium channel openers act through an activation of ATP-sensitive K⁺ channels in guinea-pig cardiac myocytes. *Pflüg. Arch.* 414:669–675.
- Fan, Z., K. Nakayama, and M. Hiraoka. 1990. Multiple actions of pinacidil on adenosine triphosphate-sensitive potassium channels in guinea-pig ventricular myocytes. *J. Physiol.* 430:273–295.
- Findlay, I., E. Deboureaix, P. Guiraudou, and E. Coraboeuf. 1989. Effects of activation of ATP-sensitive K⁺ channels in mammalian ventricular myocytes. *Am. J. Physiol.* 257:H1551–H1559.
- Findlay, I., and J.F. Faivre. 1991. ATP-sensitive K channels in heart muscle: Spare channels. *FEBS (Fed. Eur. Biochem. Soc.) Lett.* 279:95–97.
- Forestier, C., Y. Depresle, and M. Vivaudou. 1993. Intracellular protons control the affinity of skeletal muscle ATP-sensitive K⁺ channels for potassium-channel-openers. *FEBS (Fed. Eur. Biochem. Soc.) Lett.* 325:276–280.
- Forestier, C., J. Pierrard, and M. Vivaudou. 1995. Mechanism of activation of ATP-sensitive K⁺ channels by intracellular protons and K-channel-openers. *Biophys. J.* 68:A40.
- Forestier, C., and M. Vivaudou. 1993a. Modulation by Mg²⁺ and ADP of ATP-sensitive potassium channels in frog skeletal muscle. *J. Membr. Biol.* 132:87–94.
- Forestier, C., and M.B. Vivaudou. 1993b. Activation of skeletal muscle K-ATP channels by protons and lemakalim: A comparative study. *Biophys. J.* 64:A316.
- Glowatzki, E., G. Fakler, U. Brandle, U. Rexhausen, H.P. Zenner, J.P. Ruppersberg, and B. Fakler. 1995. Subunit-dependent assembly of inward-rectifier K⁺ channels. *Proc. R. Soc. Lond. B. Biol. Sci.* 261:251–261.
- Gopalakrishnan, M., R.A. Janis, and D.J. Triggle. 1993. ATP-sensitive K⁺ channels—pharmacologic properties, regulation, and therapeutic potential. *Drug Dev. Res.* 28:95–127.
- Goulding, E.H., G.R. Tibbs, and S.A. Siegelbaum. 1994. Molecular mechanism of cyclic-nucleotide-gated channel activation. *Nature (Lond.)* 372:369–374.
- Hehl, S., and B. Neumcke. 1994. Diverse effects of pinacidil on K-ATP channels in mouse skeletal muscle in the presence of different nucleotides. *Cardiovasc. Res.* 28:841–846.
- Hussain, M., A.C. Wareham, and S.I. Head. 1994. Mechanism of action of a K⁺ channel activator BRL 38227 on ATP-sensitive K⁺ channels in mouse skeletal muscle fibres. *J. Physiol.* 478:523–532.
- Jahangir, A., A. Terzic, and Y. Kurachi. 1994. Intracellular acidification and ADP enhance nicorandil induction of ATP sensitive potassium channel current in cardiomyocytes. *Cardiovasc. Res.* 28:831–835.
- Krapivinsky, G., E.A. Gordon, K. Wickman, B. Velimirovic, L. Krapivinsky, and D.E. Clapham. 1995. The G-protein-gated atrial K⁺ channel I-KACH is a heteromultimer of two inwardly rectifying K⁺-channel proteins. *Nature (Lond.)* 374:135–141.
- Lederer, W.J., and C.G. Nichols. 1989. Nucleotide modulation of the activity of rat heart ATP-sensitive K⁺ channels in isolated membrane patches. *J. Physiol.* 419:193–211.
- Mackinnon, R. 1991. Determination of the subunit stoichiometry of a voltage-activated potassium channel. *Nature (Lond.)* 350:232–235.
- Monod, J., J. Wyman, and J.P. Changeux. 1965. On the nature of allosteric transitions: A plausible model. *J. Mol. Biol.* 12:88–118.
- Nakayama, K., Z. Fan, F. Marumo, T. Sawanobori, and M. Hiraoka. 1991. Action of nicorandil on ATP-sensitive K⁺ channel in guinea-pig ventricular myocytes. *Br. J. Pharmacol.* 103:1641–1648.
- Nichols, C.G., W.J. Lederer, and M.B. Cannell. 1991. ATP dependence of KATP channel kinetics in isolated membrane patches from rat ventricle. *Biophys. J.* 60:1164–1177.
- Quast, U., K.M. Bray, H. Andres, P.W. Manley, Y. Baumlin, and J. Dosogne. 1993. Binding of the K⁺ channel opener [H-3]P1075 in rat isolated aorta—relationship to functional effects of openers and blockers. *Mol. Pharmacol.* 43:474–481.
- Quasthoff, S., C. Franke, H. Hatt, and M. Richter-Turtur. 1990. Two different types of potassium channels in human skeletal muscle activated by potassium channel openers. *Neurosci. Lett.* 119:191–194.
- Ripoll, C., W.J. Lederer, and C.G. Nichols. 1990. Modulation of ATP-sensitive K⁺ channel activity and contractile behavior in mammalian ventricle by the potassium channel openers cromakalim and RP49356. *J. Pharmacol. Exp. Ther.* 255:429–435.
- Rorsman, P., K. Bokvist, C. Ammala, L. Eliasson, E. Renstrom, and J. Gabel. 1994. Ion channels, electrical activity and insulin secretion. *Diabete Metab.* 20:138–145.
- Shen, W.K., R.T. Tung, M.M. Machulda, and Y. Kurachi. 1991. Essential role of nucleotide diphosphates in nicorandil-mediated activation of cardiac ATP-sensitive K⁺ channel: A comparison with pinacidil and lemakalim. *Circ. Res.* 69:1152–1158.
- Spruce, A.E., N.B. Standen, and P.R. Stanfield. 1985. Voltage-dependent ATP-sensitive potassium channels of skeletal muscle membrane. *Nature (Lond.)* 316:736–738.
- Terzic, A., A. Jahangir, and Y. Kurachi. 1994a. Hoe-234, a second generation K⁺ channel opener, antagonizes the ATP-dependent gating of cardiac ATP-sensitive K⁺ channels. *J. Pharmacol. Exp. Ther.* 268:818–825.
- Terzic, A., A. Jahangir, and Y. Kurachi. 1995. Cardiac ATP-sensitive K⁺ channels: Regulation by intracellular nucleotides and K⁺ channel-opening drugs. *Am. J. Physiol.* 38:C525–C545.
- Terzic, A., R.T. Tung, and Y. Kurachi. 1994b. Nucleotide regulation of ATP sensitive potassium channels. *Cardiovasc. Res.* 28:746–753.
- Thuringer, D., I. Caverro, and E. Coraboeuf. 1995. Time-dependent fading of the activation of K-ATP channels, induced by aprikalim and nucleotides, in excised membrane patches from cardiac myocytes. *Br. J. Pharmacol.* 115:117–127.
- Thuringer, D., and D. Escande. 1989. Apparent competition between ATP and the potassium channel opener RP 49356 on ATP-sensitive K⁺ channels of cardiac myocytes. *Mol. Pharmacol.* 36:897–902.
- Unwin, N. 1995. Acetylcholine receptor channel imaged in the open state. *Nature (Lond.)* 373:37–43.
- Venkatesh, N., J.S. Stuart, S.T. Lamp, L.D. Alexander, and J.N. Weiss. 1992. Activation of ATP-sensitive K⁺ channels by cro-

- makalim—effects of cellular K^+ loss and cardiac function in ischemic and reperfused mammalian ventricle. *Circ. Res.* 71:1324–1333.
- Vivaudou, M.B., C. Arnoult, and M. Villaz. 1991. Skeletal muscle ATP-sensitive potassium channels recorded from sarcolemmal blebs of split fibers: ATP inhibition is reduced by magnesium and ADP. *J. Membr. Biol.* 122:165–175.
- Vivaudou, M., and C. Forestier. 1995. Modification by protons of frog skeletal muscle K-ATP channels: Effects on ion conduction and nucleotide inhibition. *J. Physiol.* 486:629–645.
- Weik, R., and B. Neumcke. 1990. Effects of potassium channel openers on single potassium channels in mouse skeletal muscle. *Naunyn-Schmiedebergs Arch. Pharmacol.* 342:258–263.