



Research article

Characterization of the information system integrated to the construction project management systems

Luvis P. León-Romero^{a,b}, Mario Aguilar-Fernández^{a,*}, Amalia Luque-Sendra^b,
Francisco Zamora-Polo^b, Misaela Francisco-Márquez^a

^a Instituto Politécnico Nacional, Unidad Profesional Interdisciplinaria de Ingeniería y Ciencias Sociales y Administrativas, Av. Té 950, Col. Granjas México, CP. 08400, México City, Mexico

^b Universidad de Sevilla, Departamento de Ingeniería del Diseño. Escuela Politécnica Superior, Virgen de África, 7. 41011, Sevilla, Spain

ARTICLE INFO

Keywords:

Project management
Information systems
Viable systems model
Lean construction
BIM

ABSTRACT

The construction industry wields significant influence in the economies of various countries. However, compared to sectors like manufacturing and aeronautics, it has lagged in terms of digitalization of processes and project management advancement. This study aims to explore how the integration of Lean principles, Building Information Modeling (BIM), and Project Lifecycle Management methodologies within an information system can enhance decision-making in construction project management as a complex environment. A comprehensive literature review was conducted to establish a conceptual framework and gather necessary information for designing an information system. The design was based on the viable systems model and the soft systems methodology, from a systemic perspective that encourages the synergistic interaction of these methodologies. The resulting abstract model would facilitate a comprehensive understanding of the interconnectedness of these methodologies, emphasizing collaborative work environments for efficient information management. This approach aims to replace the current isolated application of each of those methodologies and promises improved project management performance.

1. Introduction

The construction industry holds great importance in the economies of many regions [1]. Nevertheless, its fragmented nature leaves gaps that require attention for improvement [2,3]. Projects within this sector often encounter unpredictable and complex situations, commonly referred to as VUCA (volatility, uncertainty, complexity, and ambiguity) environments, which hinder the ability to accurately predict performance and success. Furthermore, project performance in the construction sector has a significant impact on the industry itself and as on the economy of the implicated countries [4–6].

Previous studies have shown that some organizations still rely on traditional project management methods, claiming that they yield satisfactory results. Other organizations have adopted alternative methodologies to enhance their performance. However, research suggests that the outcomes of such efforts could be improved, as evidenced by project productivity indices [2,7]. Some studies indicate that implementing tools in isolation has not yielded convincing results and the impact on the sector has been insignificant presenting low percentages of on-time deliveries, non-compliance with initial budgets, and deficiencies on digitization of processes [8].

* Corresponding author.

E-mail address: maguilarfer@ipn.mx (M. Aguilar-Fernández).

<https://doi.org/10.1016/j.heliyon.2024.e31886>

Received 28 June 2023; Received in revised form 22 May 2024; Accepted 23 May 2024

Available online 25 May 2024

2405-8440/© 2024 The Author(s). Published by Elsevier Ltd. This is an open access article under the CC BY-NC license (<http://creativecommons.org/licenses/by-nc/4.0/>).

Abbreviations

BIM	Building Information Modeling
PLM	Project Lifecycle Management
LC	Lean Construction
VSM	Viable System Modeling
ISO	International Organization for Standardization
PMBok	Project Management Body of Knowledge
VUCA	Volatility, Uncertainty, Complexity, and Ambiguity

The study aims to improve efficiency in design and construction processes by integrating proven practical tools in other sectors [9]. To achieve maximum effectiveness in project management [10,11], this paper proposes the integrated use of Building Information Modeling (BIM), Lean construction, and Product Lifecycle Management (PLM), rather than using them in isolation as is common today. The proposed integration of these methodologies is achieved through the design of a digitized comprehensive information system [12], based on the model of viable systems formulated by Beer [13] from the fundamental principles of recursion or fractality, autonomy, cohesion, and viability [14]. This approach requires a greater commitment from all stakeholders and strengthens the flexible standardization of processes through digitization.

2. Literature review

2.1. Project management

According to the Project Management Institute project management is described as the application of knowledge, skills, tools, and techniques to activities developed within the framework of the execution of a project with the purpose of fully meeting the established requirements [15]. The use of methodological tools that help to improve the decision-making process to ensure a better result according to the objectives set. However, some authors recognize that traditional project management based on the PMBOK methodology and the ISO standard, have limitations and difficulties in achieving the objectives, affecting costs, time, quality, and human resources [16]. This is partly because the traditional mode is based on the following three stages: bidding, planning, and construction, under a scheme of individualistic work where communication between the parties is poor, each agent performs just to the point that concerns to their responsibility, leaving aside what the project requires [7]. Other causes of unachieved objectives are attributed to the fact that traditional methodologies focus their attention on cost control, downplaying the importance of preliminary phases such as planning and context analysis, as well as their distance from the creation of collaborative spaces in the early stages of the project [11]. This highlights the need to migrate towards flexible methodologies that address such shortcomings from systems integration [17], which is essential for the design and execution of large projects with many interconnected activities, that give them the characteristic of complexity [17,18].

2.2. Information systems in project management

Digital tools in the field of project management are useful to optimize the development of the line of work [19,20] and allow characterizing it within the so-called industry 4.0 [21]. The use of technological equipment contributes to minimizing errors, increasing speed and accuracy, if they are properly used [8,22]. The evolution of information systems has implemented simulation techniques that contribute to significantly reduce constructions' errors from their initial design phases [23]. Information systems are a great help in complex projects where several actors involved who require available and updated information to make the best decisions for avoiding delays and extra costs in their results [24]. From this tool, daily operations are in constant connection with administrative and strategic activities allowing better management of processes, especially the critical ones. Information systems allow connectivity, communication, and automation from the access and management of information and can contribute to reduce rework [25]. However, in the construction sector difficulties persist [26].

2.3. Project management in the construction sector

Construction is a sector constantly growing and it is very important for the economies of most countries around the world. However it is a sector of slow growth in project management and digitization, factors that affects this sector's productivity [7], when it is compared to other sectors such as aerospace, automotive and manufacturing [11]. So it is necessary to contribute to the efficiency of its processes [23] to avoid failing to comply with delivery times and costs previously established [27]. In addition to reduce its environmental impact and incidences in its work labor activities [19]. On this article, we evaluate strategies from the dynamic systems abstract model applied on the life cycle of construction projects, to support the integration and interaction of variables from an information system for making more efficient decision-making processes that have direct impact on the performance of projects [3,4].

The most relevant problems in the management of construction projects are related to the compliance with the deadlines established to deliver results [28], the establishment of budgets, the management, the availability of good quality information in real time,

the integration of the actors within the project [11], and the digitalization of the processes [7], as uncertainty is a characteristic of all these factors [29]. Therefore, this work focuses its attention from the systemic perspective on the creation of an abstract model where methodologies that have been successful in other industries. Applying them in a compact and not isolated way, as they have been applied so far. Resulting until these days on a non-evident significant advancement for the sector.

Several studies indicate that the average compliance of construction projects is between 25 and 30 % and this is due to various causes and pressure of the environments in which these projects are developed. One of the reasons for these results is the level of complexity given by the wide network of participants involved and required to be interconnected. Decisions of a stakeholder affect another's and finally this is reflected in the comprehensive management of the project in the medium and long term. Results of the effectiveness are based on the feedback in the interdisciplinary group that constitutes the project there is not always proper traceability of this communication process. In addition, up to 49.7 % of the time spent does not generate value [11]. The system approach from a common technological platform, it is very useful for the management of each of the stages of the life cycle of construction projects. The integration of information systems in a project is relevant for reducing the degree of uncertainty that exists due to the nature of the sector. The dynamic analysis of the system is a significant contribution from the perspective of learning in the productivity and performance of the project is properly shared [8–10].

2.4. Complexity of a project

Projects that are considered complex systems have benefited due to the introduction of tools based on space and design information. These tools have achieved important efforts establishing a system that provides efficient information throughout the life cycle of the project. To improve competitiveness, it is necessary to use systemic thinking as a mechanism to manage it and ensure its success. Complexity is more accentuated to the extent that environmental changes (technological, socioeconomic, governmental, environmental, cultural) advance rapidly and without predictions [30]. The complexity of a project is approached from two angles: one holistic, where the objective is related to the project execution process; and one analytical, which allows the detailed definition of the subsystems and their reciprocal interrelation. These two perspectives will be relevant for making holistic decisions affecting the overall project due to the performance in a complex environment (understanding by environment the relationships that the project must consider and that cannot be controlled or changed) before the project needs to adapt to it [31]. Authors [32] agree that complexity is also due to the characteristics of the type of project in which variables such as project scope, geographic location, and labor force are evaluated; and the relationship of these variables impacts on the execution and development of the project, bearing in mind the risks of the activity that may endanger human life.

2.5. Building Information Modeling (BIM)

BIM is considered a useful design methodology for the execution stage of a construction project. However, it is certainly idealized for use in every phase of the project life cycle. This methodology contributes to the improvement of information processing, better communication flow [11], data interoperability throughout the work team, and provides the opportunity to have a common language available to all at any time; allows being aware of project changes in real time and performing verifications before implementation, whether it is convenient or not, according to its principle of inference detection [22]; and also contributes to improve the sustainability of the project [33,34]. The methodology is used in a very limited way [35]. Its use should go beyond the 3D (level where the 3D model is made), where it is frequently used. The relevance of levels 4D (level where the 3D model and the estimation of project activities are included) and 5D (includes 3D model, time estimation and project costs) [36] represents a great contribution for the scheduling of activities, establishment of calendars and costs control. While the 6D level contributes to the sustainability of the project, and the 7D as a tool for the maintenance operations of the facilities [16,20,37].

2.6. Lean Construction (LC)

LC is a philosophy that promotes the reduction of waste such as rework, unnecessary movements, duplication of operations [38], and contributes to promote collaborative work [39]. Thus, it saves time and costs [22]. It's a philosophy that seeks to increase value in the processes for the customer [11,40], among its tools there are: Just in Time, Kanban, Last Planner System, value stream, integrated delivery of projects. This philosophy is favorable for the construction sector because it contributes to improving productivity, increasing performance, quality, and the environment [41]. Likewise, it reduces costs, intangible waste such as leisure time and accidents [42], it focuses on control and planning from the integration of stakeholders to avoid waste and contributes to generate value for the customer [41].

2.7. Product Lifecycle Management (PLM)

PLM is considered an organizational activity with emphasis on the optimal management of products, services, and the pieces that constitute it. From the high volumes of information that are generated in this work, on an integrated manner throughout its life span, starting from the idea until the final stages such as the withdrawal and disposal of the product or service [43,44]. This methodology, like lean, is on the way to increase value for the customer and other stakeholders as a collaborative system [45], and to achieve effectiveness of the project under development [46]. As a business strategy, it requires processes to be standardized and focuses directly on the creation, management, dissemination, and collaborative use of information for product or service definition [47]. It

provides the opportunity to integrate people, processes, systems, and information. It links information and knowledge through process control, hence the need for standardization [48]. As a limitation, there is no clear way to carry out the application of such a business strategy to have a successful information management [49].

2.8. BIM and Lean Construction

Some authors propose the integration of BIM and Lean construction as a mechanism to increase the productivity of the sector. It is also indicated that 91 % of the entities believe necessary a systematic change in terms of project management and 80 % of the same population agrees with the inclusion of techniques from the industrial area [11]. A point in common between these two currents is the collaborative approach between project stakeholders [50], and the fact that together they generate several benefits, such as maximization of projects productivity [10,40,51]. This application covers the planning, scheduling, and operation control processes in a construction project [37,52]. Unfortunately, there is still little research carried out to analyze the integration of these methodologies.

2.9. BIM and PLM

They are considered as computer systems [53]; PLM, from its strategic approach, supports all stages of the life cycle of the product, service, or project, which generates a source of data linking people, processes, technologies, and information. This allows the latter to be stored and consulted when it's required [54]. This is the fundamental basis on which BIM is supported in the construction sector. While PLM starts with the project idea, BIM arises in the design phase where its major application is focused [55]. However, according to its purpose, it should be present in each phase of the project until the product's final disposition as PLM does. The main difference between them is the field of application, while BIM is mainly used in the construction sector; PLM is used in complex projects in the aerospace and aeronautical area [56].

2.10. PLM and LEAN

The integration of these two concepts is less common. Those who have risked searching for continuous improvement through best practices offered by Lean and PLM tools study it from an innovative environment for sustainable development and profitable organizational growth [57]. This relationship between PLM and Lean is usually applied on the manufacturing sector suitable for repeatable and responsive business processes from technological tools that aligned to the objective that constitute them. This combination offers as an organizational advantage the saving of time and resources because it minimizes the need for changes [58]. For his part, N. El Faydy et al. state that PLM and Lean are suitable for Industry 4.0 due to their favorable performance in standardization, automation, and use of technological tools to improve the performance of organizations [59]. However, E.F. Nada and E.A. Laila argue that despite the benefits of this relationship of concepts, it has not been successful due to the lack of models that contribute to the implementation; and in the field of research, there are few works that relate them [60].

After conducting a literature review, it has been detected that the intricacy of managing construction projects needs the development of strategies. The most effective strategies are those that prioritize integration and collaboration through a constant exchange of information. This is mainly critical for decision-making purposes, as demonstrated by using agile methodologies during the design phase of a project [61].

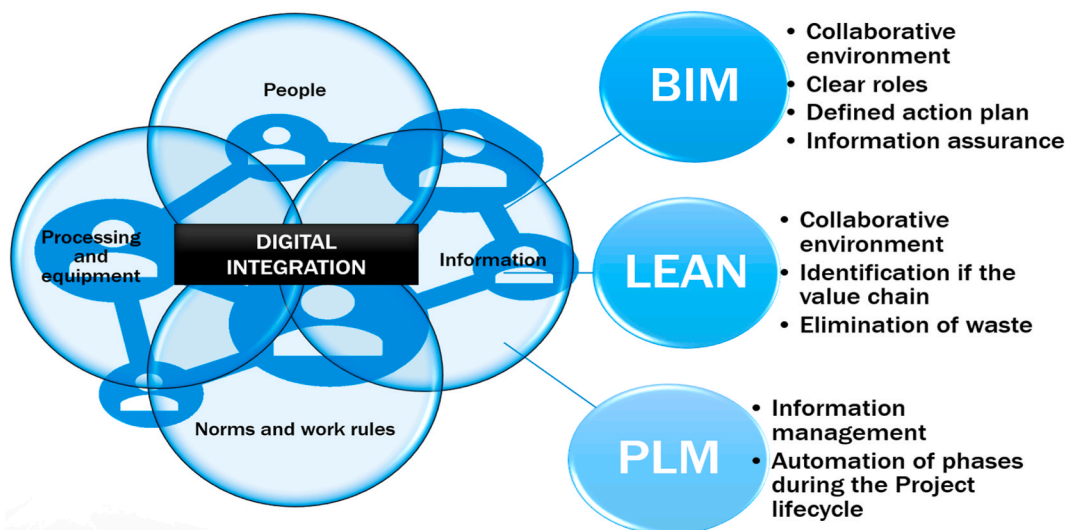

Fig. 1. Integration and contribution of the support tools for the design of the information system.

Agile methodologies and lean philosophy share similarities in the design phase, and some research has shown positive results in this area. However, according to Owen et al. (2006) [62] the construction phase of a project involves a more diverse team, and the temporary nature of these teams makes it challenging to implement agile practices from design to construction consistently. Nevertheless, this research aims to fill significant knowledge by establishing a methodology that links design and construction. Therefore, this work proposes the integration of Product Lifecycle Management (PLM) for managing the entire life cycle of a project, Lean Construction as a flexible and collaborative philosophy to reduce waste and idle time; and Building Information Modelling (BIM) for efficient management of information from all project stakeholders. These three methodologies have a high degree of compatibility and approximation in their purpose. Fig. 1 shows how these three methodologies have common points that facilitate their integration. The proposed relational link between these three methodologies would ensure that the team is constantly communicating and aware of changes throughout the project stages, encompassing both processes.

On the other hand, adopting a systemic approach in this type of study is essential. However, this approach was not evident in the review. The processes seen are often linear, with one group entering and the other leaving according to the order of work planning. To better understand a project, it is relevant to analyze the environments that surround it, including systems, subsystems, and macro systems. This analysis helps to identify the elements that affect the project and how they influence it. It is significant to note that these elements should be considered as a whole, as they are interconnected and cannot disperse, as is evidenced in the literature. Analyzing a system from a process perspective helps to improve productivity and efficiency, leading to lower costs and timely deliveries. The continuous flow of reliable information from the technological field improves flexibility and aids decision-making [19]. From a human team's perspective, it promotes communication, collaboration, learning, and interdisciplinary exchange of ideas. Additionally, it reduces waste generation and optimizes resource utilization, thus contributing to environmental sustainability [3,33].

This research allows project managers and policymakers to know that systematic and global analysis and early stakeholder integration permit improved decision-making, making it essential to consider them as an initial step.

To develop the system dynamics abstract model, we used the soft systems methodology presented by Checkland [63,64], structured with the meta-methodology presented by Sterman [65]. Using causal diagrams from the I. think 8.0 systemic modeling software, these models were created [66].

3. Materials and methods

Projects cannot be classified as linear systems since they are susceptible to various environmental and context variables. Due to their nature, unexpected behaviors often emerge, making it challenging to predict their execution and future development. Therefore, systemic methods must be employed to manage them effectively.

Considering Sterman's teachings [65], this qualitative research used the soft systems methodology developed by Checkland [63] which consists of an integrated learning cycle of 4 types of activity: 1) perceived problem situation, 2) purposeful activity modeling (based on worldviews), 3) comparison and structured discussion about change, and 4) improvement actions [64].

These teachings establish that digital environments accelerate learning and aid in problem-solving through models. By bringing real situations to the virtual environment while preserving their most significant characteristics, these abstract models contribute favorably to project management.

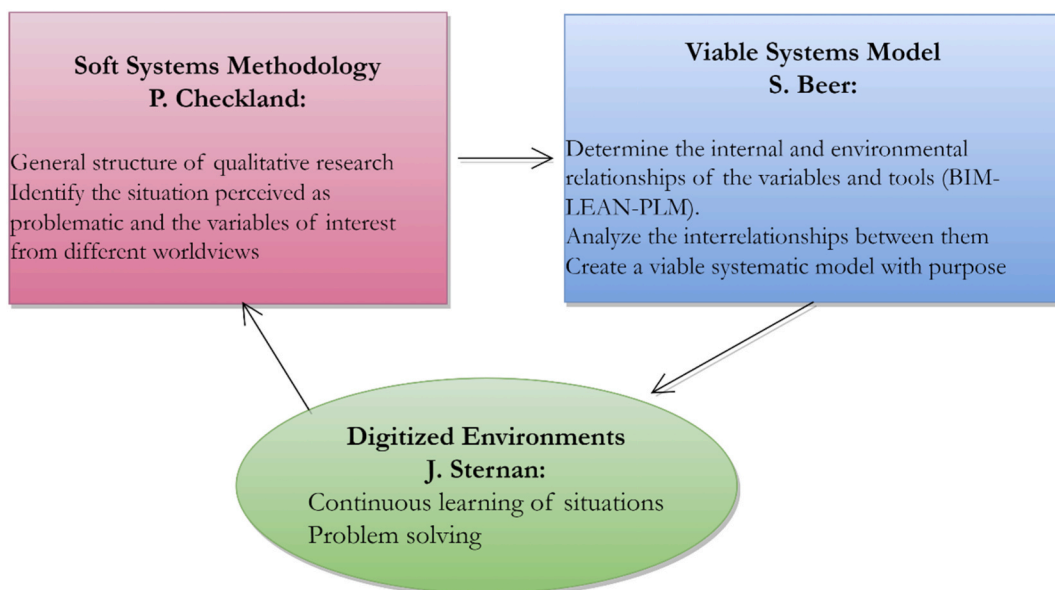

Fig. 2. Graphical representation of the interdependence of these methodologies.

This study aims to connect Lean Construction philosophy and Building Information Modeling (BIM) within the Project Lifecycle Management (PLM) framework.

To develop this work, we started by identifying the problematic situations, which came from different world views. Then, the variables involved in this situation were determined. Subsequently, the relationships and connections between these variables using the viable systems configuration of Stafford Beer [67] were analyzed. This study involved examining the variables' behavior while considering the internal and external environment situations. This methodology was then specifically applied to project management in the construction sector. Fig. 2 provides a graphical representation of the interdependence of these methodologies.

3.1. Identification of the problem situation and variables of interest

Starting from the identification of an actual situation that is perceived as problematic, of which there are different worldviews, the variables of interest and their relationships are determined and then taken to a purposeful model. This model provides questions about the situation, allowing to explore and create a structured discussion to address those worldviews towards a desirable change for the system under study [10]. Fig. 3 shows the stages of the research development using the soft systems methodology.

- Definition of the problem situation
- Analysis from different world views
- Structure of possible solution systems
- Creation of a purposeful model, following Stafford Beer's methodological structure.
- Model response vs. reality.
- Desirable changes are systematically feasible with the culture.
- Action for improvement and learning, according to Sternan's methodology.

3.2. Creation of a purposeful model based on the relationship between variables

To design the model, the viable systems proposed by Stafford Beer were followed [67]. It is crucial to ensure that all systems are interconnected with the subsystems and macro systems to achieve accurate results. Some people tend to overlook this fact and do not reflect its value in the proposed methodologies. This is pointed out in Fig. 4 to understand the recursion of the system and how it fits into other extensive systems while containing smaller ones.

- Identify the external and internal environment with its variables.
- Classify the internal variables according to each type of system (basic operations, information, measurement and auditing, strategies and future planning, policies, values, and internal regulations for decision-making).

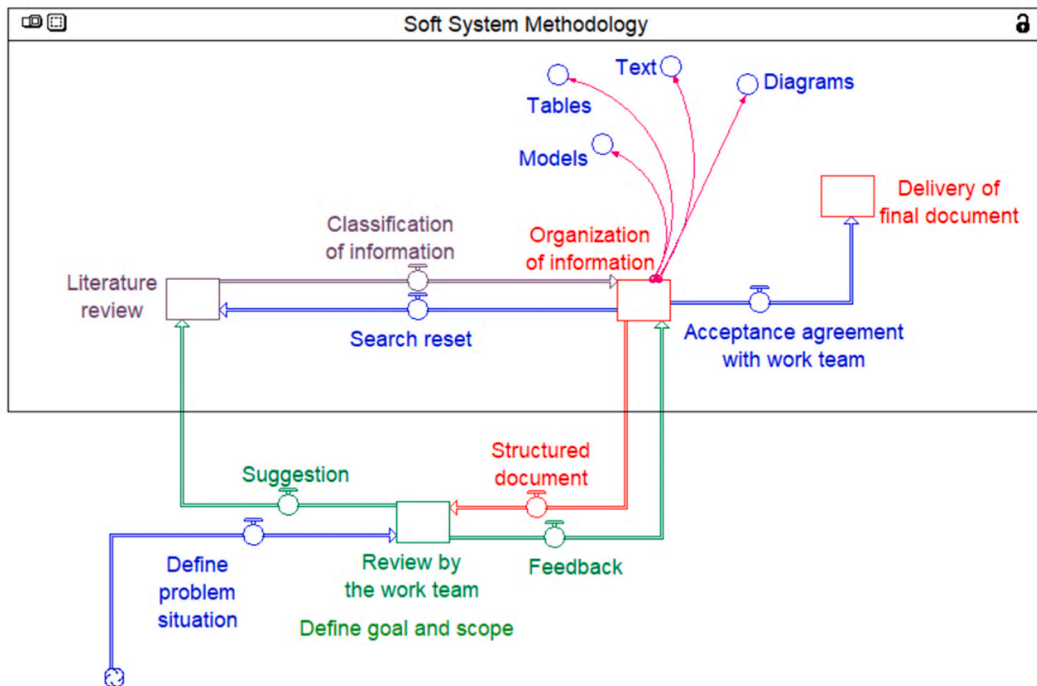

Fig. 3. Soft systems methodology applied to the research process.

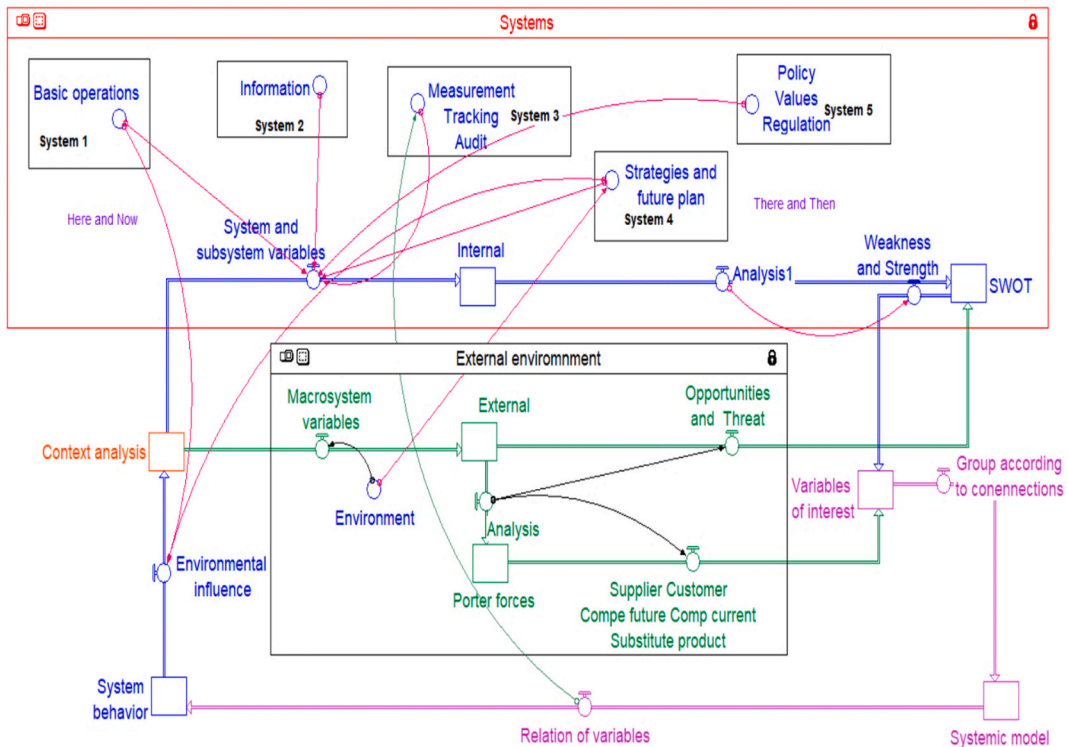

Fig. 4. Representation of the methodology based on Beer's model.

Identify the relationship of the variables between systems and with the environment.
 Recognize strengths, threats, weaknesses, and opportunities.
 Structuring a systemic relationship model of internal and external variables to know the influence between the interconnections.

3.3. Continuous feedback and learning process of the system

According to Sterman [65], experience helps to improve the virtual representation with each modeling cycle, while experiments provide new information to alter realities. The model represents reality in a simplified form. Fundamental changes generate new problem situations that are addressed by identifying essential variables, analyzing historical behavior, and formulating new hypotheses using the Checkland model. In summary, the model is crucial as it simplifies reality and helps to identify limitations and

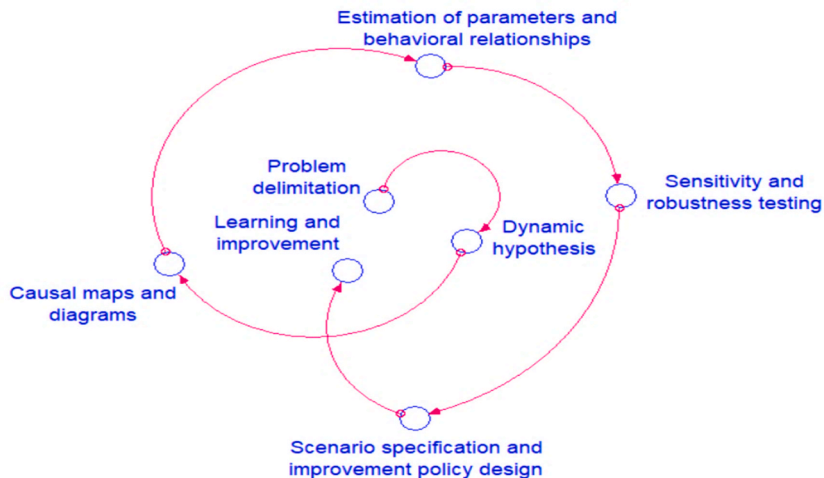

Fig. 5. Methodology considering Starman's essential steps. Adapted of [65].

generate new hypotheses.

Following Sterman’s approach, we adhere to the general steps outlined below:

- Delimitation of the information system (its scope, objectives, essential variables, historical and future behavior).
- Formulation of hypotheses and dynamics of the feedback structure. Feeding of world visions as proposed by Checkland.
- Elaboration of the causal map, subsystem diagram, actions, and information system flow for subsequent purposeful modeling.
- Estimation of parameters, behavioral relationships, and initial conditions.
- Sensitivity and robustness test according to its purpose.
- Scenario specification and design of improvement policies.
- Learning and improvement of the proposed model.

The previous steps are summarized graphically in Fig. 5. As presented by Sterman, modeling represents an iterative process of continuous improvement and learning from the concrete world through virtual environments that allow the system to evolve.

I think 8.0 software was used to create the systemic models, which was useful for modeling and simulation of complex problems in the system dynamics environment; allowed the generation of models for the purpose of performing analysis in different scenarios having variables that are attributed properties and parameters to identify them and interconnect with others [68].

4. Results

4.1. General description of systems

A project considered a system is part of a larger system (macro system) which has properties that affect and are affected by its execution. In this system, there are variables such as government, technology, culture, market, competitors, resources, and shareholders. In the development of the project, collaborative work, active communication, timely information, efficient decisions for a gear and success in the expected results. In addition, it is also integrated by subsystems. These are smaller and are located inside, some of them are: basic complex systemic atmosphere because of the number of variables and interconnections that arise between them as shown in Fig. 6.

operations subsystem, information subsystem, audit subsystem, strategic subsystem, and subsystem of policies and values for decision-making. When they interact, they create a

As mentioned before, the project is also integrated by other systems. When they are well-coordinated, contributing to increasing the efficiency in processes such as decision-making and, therefore, in results obtained. According to the systemic structure proposed by Stafford Beer, there are 5 subsystems that are also impacted and have influence with an external environment. It is important to consider that not all systems have direct connections with each other, but they are affected by indirect relationships as shown in Fig. 7.

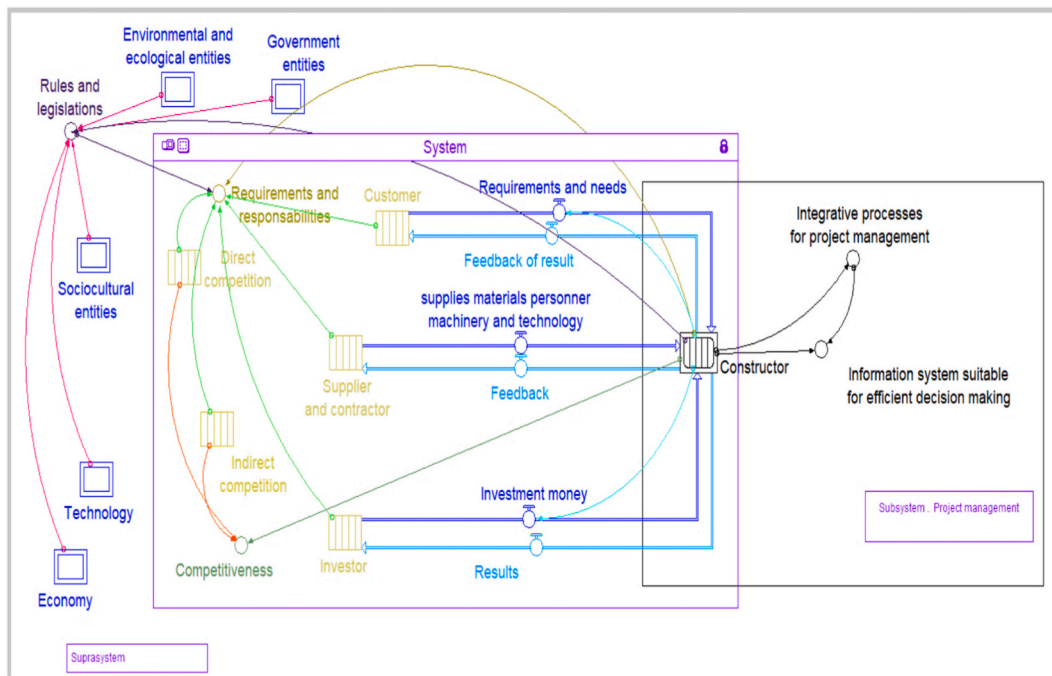

Fig. 6. Environments with which a system is related.

4.2. Construction project management

The management of construction projects is determined by four main variables as listed below.

- Customer requirements.
- Information system as a means of interconnection.
- Digitalization and flexibility of processes.
- Customer satisfaction as a point of adjustment for continuous improvement.

The benefits obtained by the integration of these variables from the BIM-Lean Construction-PLM integrated model is summarized in Table 1, where four categories of interest in construction projects are identified.

The causal interconnection of the variables that interact in the management of construction projects is shown in Fig. 8.

The processes and stages are represented in Fig. 9, where the stages and phases that are part of construction project management are shown.

Similarly, Table 2 identifies the phases or stages of the project in which each methodology has the greatest impact for its application.

Management based on the control and analysis of risks and restrictions, appropriate management of information and communication, continuous monitoring of operations and execution of structured plans are necessary to make timely decisions throughout the project life cycle, favoring the efficiency and productivity of the sector. Including generation of value for the client through the improvement, and flexibility of its internal processes and interconnections with their environments. Fig. 10 shows the abstract model dynamics of action of project management in the construction sector integrating Lean Construction, BIM and PLM.

The project dynamics begin with the client’s requirements, where they discuss time, cost, and quality concerns. There is constant communication among the parties. If the project is accepted and assigned, communication continues, including feedback with suppliers and contractors to initiate the implementation of the project. Factors related to costs, delivery times, and feasibility are also considered. In parallel, potential problem situations are identified, which include analyzing restrictions and risks. There is online follow-up in real-time to provide a timely solution. All of this is done while considering the proposed tools, namely LEAN, BIM, and PLM, to ensure the project is completed according to the requirements, with improvement actions throughout the execution where all interested parties participate actively.

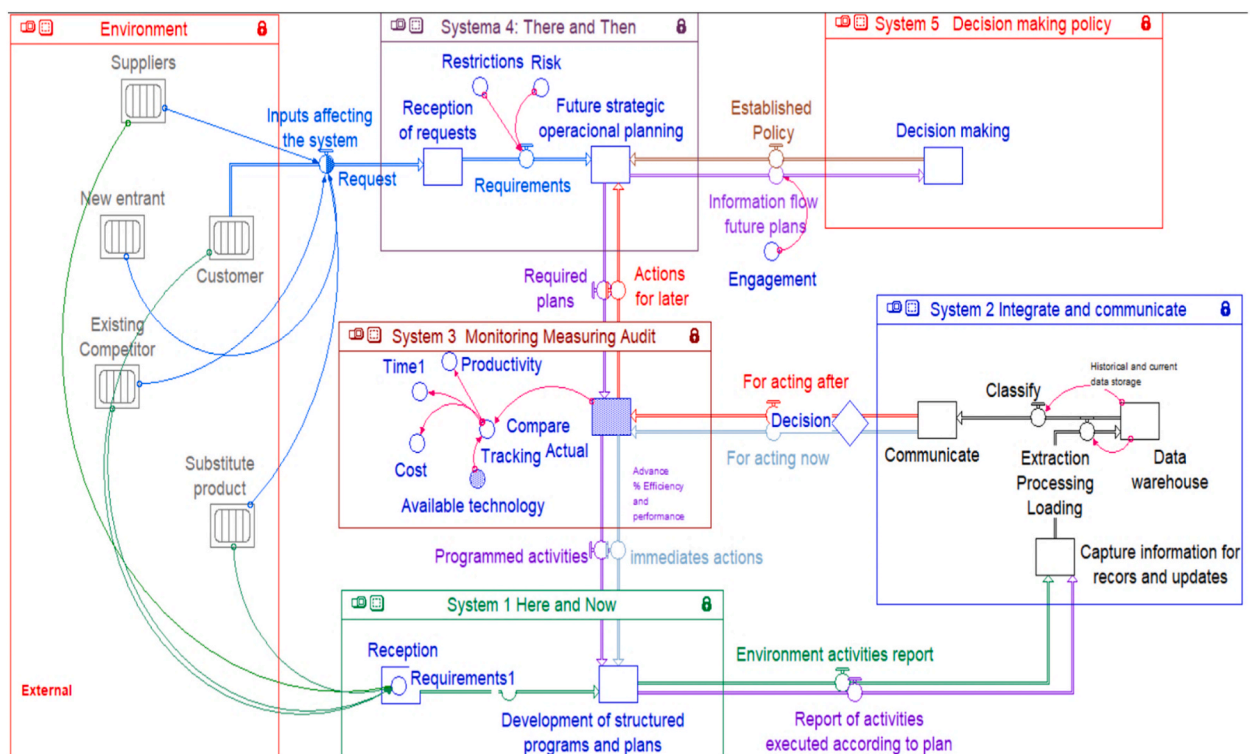

Fig. 7. Relationship between the systems from the viable systems model proposed by Beer and Porter’s forces present in the external environment.

Table 1
Benefits of the integration of BIM-Lean Construction – PLM system in construction projects.

Category	Integrated system benefits BIM-LEAN-PLM				
Process	Cost and time efficiency	Continuous flow	Flexibility	Adaptability - Competitiveness	Continuous improvement
Technology	Control of digitized information	Interoperability	Previous simulation	Conflict identification	Reliable decisions and efficiency
Stakeholder	Collaboration	Communication	Integration	Knowledge	Training
Socioenvironmental	Waste reduction	Sustainability	Integrity	Systematic empathy	Added value

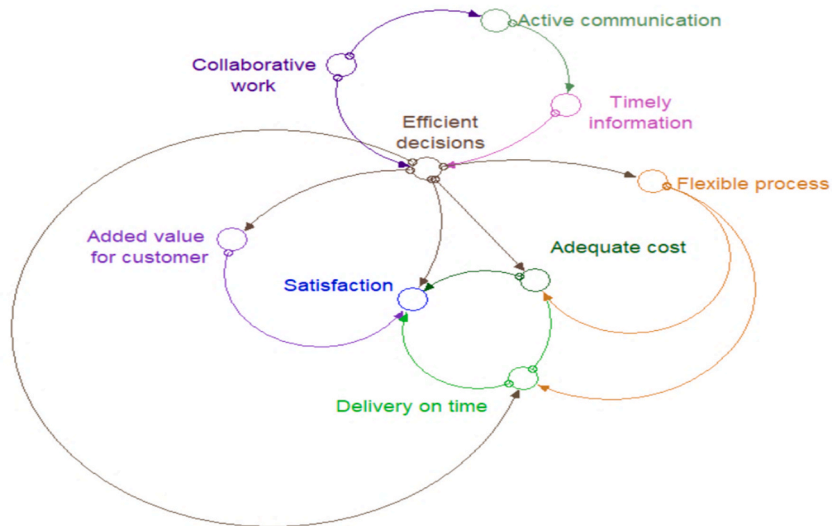

Fig. 8. Causal relationship between the most relevant variables for project management.

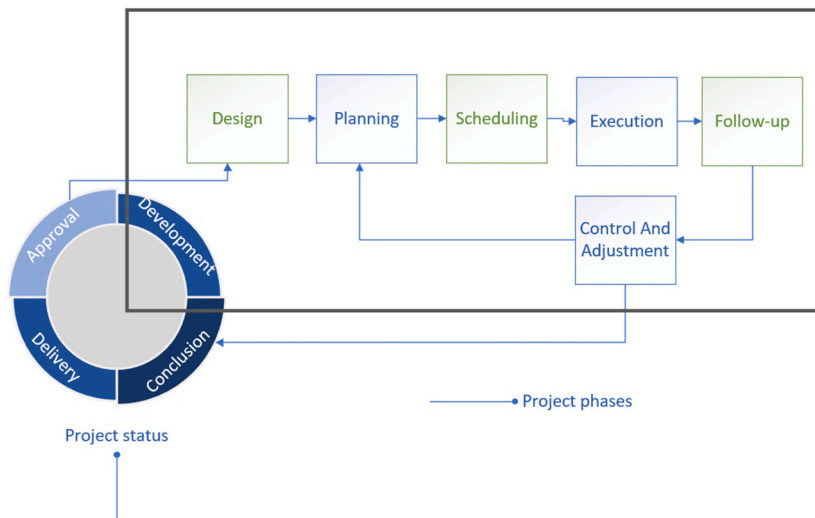

Fig. 9. Stages and phases part of a construction project.

4.3. Detail in system 2 (information system)

The information system, by capturing information, selects, cleans, stores and shares information when it is needed for decision-making. The information that is not shared is stored for future consultation according to events, as shown in Figs. 11 and 12.

The information system in evidence is not isolated, it has a direct connection with systems 1 and 3. System 1 provides information and system 3 receives it from system 2. Graphically, these processes are shown in Fig. 13.

Table 2
Impact on project phases for each methodology integrated in the model.

	Design	Planning	Scheduling	Execution	Follow-up	Control and adjustment
BIM						
LEAN						
PLM						

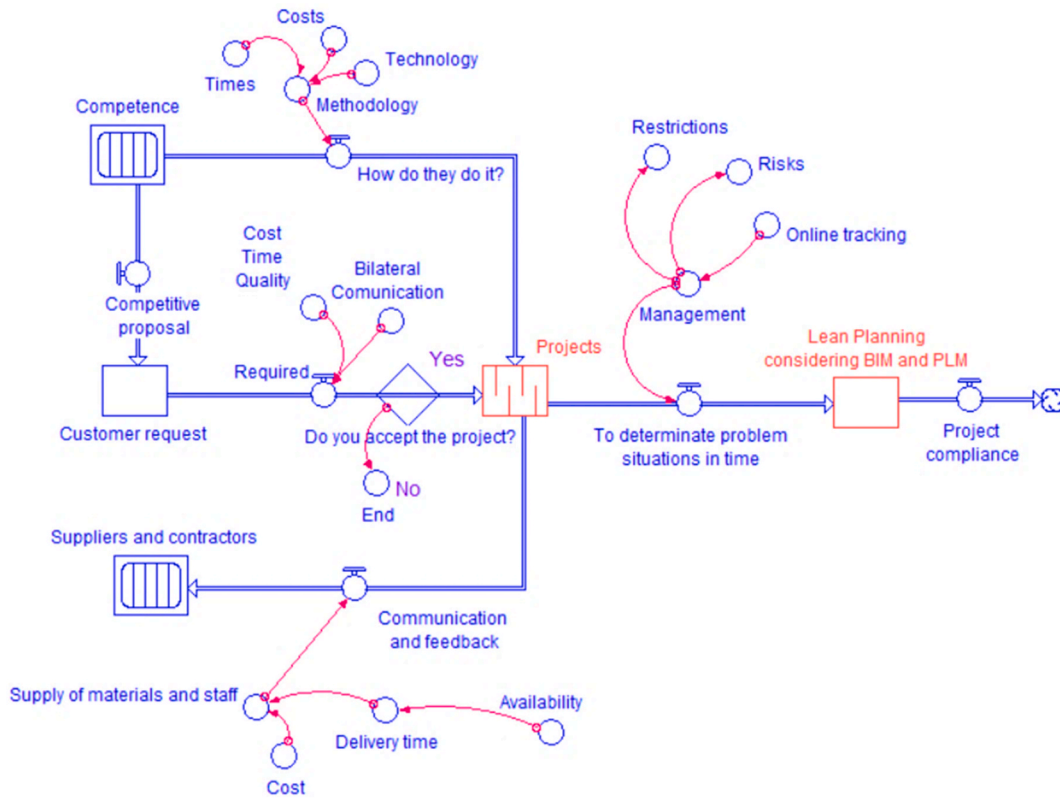

Fig. 10. Action dynamics of project management in the construction sector integrating Lean, PLM, and BIM.

The inputs to system 2 come from system 1, where work plans are executed, and all immediate actions required by the system are carried out. Always responding to project’s necessities on a “here and now” responsiveness; Project’s needs do not wait to be processed by other systems because they are considered of vital action to prevent undesired results in the project. The outputs of system 2 reach system 3 where they are compared to the standards and indicators established as a measure of achievement against the established objectives. Any deviation observed can take one of the two paths enabled: on one hand, if it requires immediate action, it will return to system 1 for its prompt execution; or if it requires an analysis and future execution plan, it will go to system 4 where strategically, and together with system 5, necessary actions will be taken according to preestablished policies. Appropriate strategic plans will be implemented to correct such deviation.

Finally, Fig. 14 reflects the integration of the project statuses with the management stages and the intervention of the information system for decision-making through the project life cycle.

5. Discussion and conclusion

Several authors agree on minimizing the existing fragmentation gap between stakeholders and digitization of processes in the construction sector, as a mechanism that allows better results, especially the compliance of time and costs [7,12,20,44,60]. The link of tools that contribute to collaborative work is suggested for this purpose [42] as showed in the projected model from a global systemic

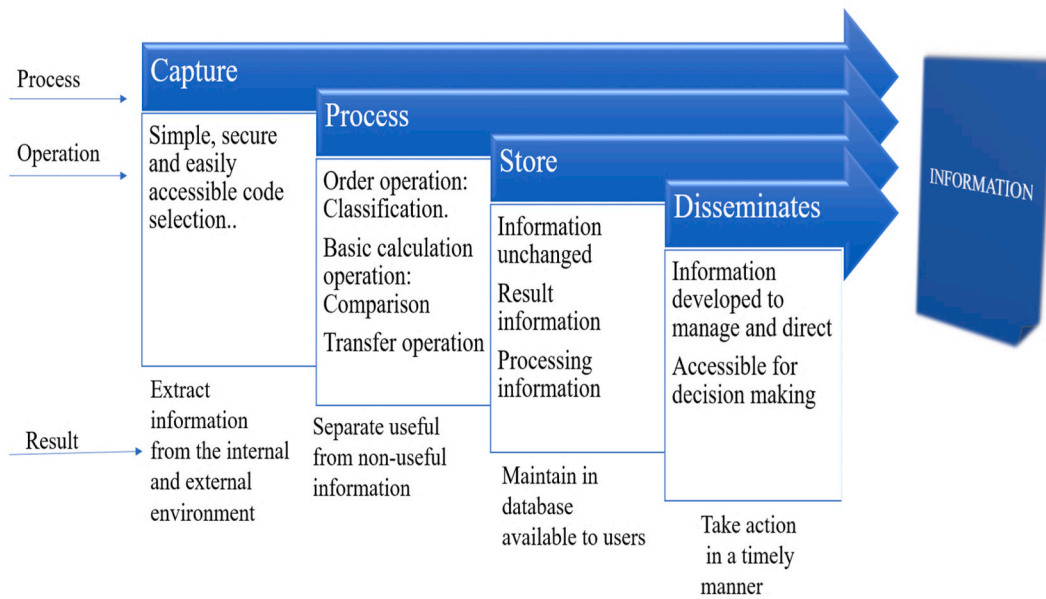

Fig. 11. Relationship of processes, operations, and results in the performance process of system 2 (information system).

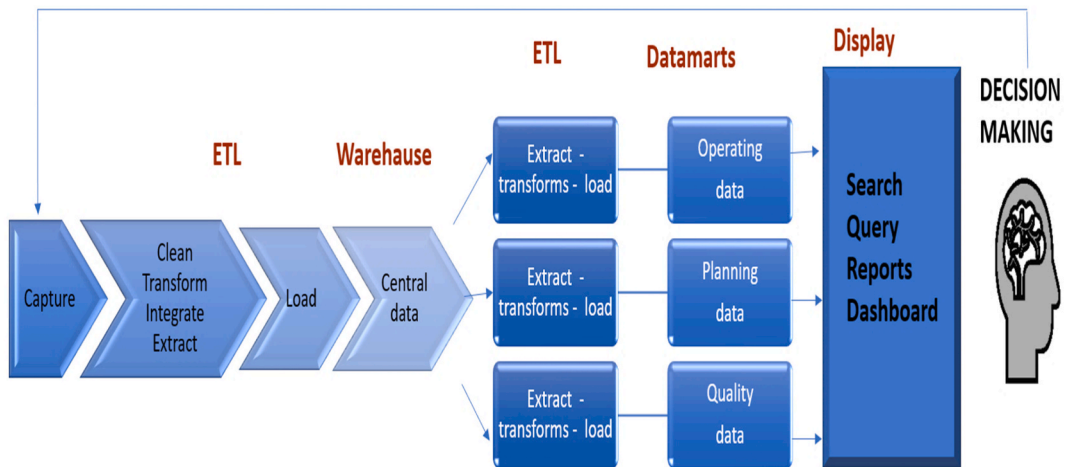

Fig. 12. Internal process of system 2 in the management of information for decision making.

perspective is not linear, as its usually carried out in most solutions suggested to date.

In the literature, there are studies focused on the unification of methodologies like BIM and PLM. The model designed for the integral consolidation of information [67], proposed to overcome the static vision of the digital model, that supports the communication process [68], and considered a strategic management information system. However, they recognize a significant degree of uncertainty in this methodological combination [69]. Since, in practice, project management is based on activities rather than on information [70]. This proposal focuses on strengthening the communication process based on quality information available to all stakeholders.

Another combination carried out in the sector is BIM plus Lean Construction helping to reduce errors and waste [56] and, in general, offering a holistic improvement in project management [71]. Eldeep et al. (2022) studied the barriers that prevent the achievement of the objectives regarding the application of BIM and Lean construction. Also stated the level of acceptance and application of this association is shallow in the sector due to the lack of research [72]. Another aspect stated by these authors, is the lack of knowledge of the benefits of integration and awareness of professionals and regulations in the sector [73]. By observing the connection points of these methodologies, we arrived at this research proposal, which is the compatibility of the tools that facilitate management.

The combination of PLM and Lean is seldom used in the construction industry. It is more frequently applied in the aeronautical

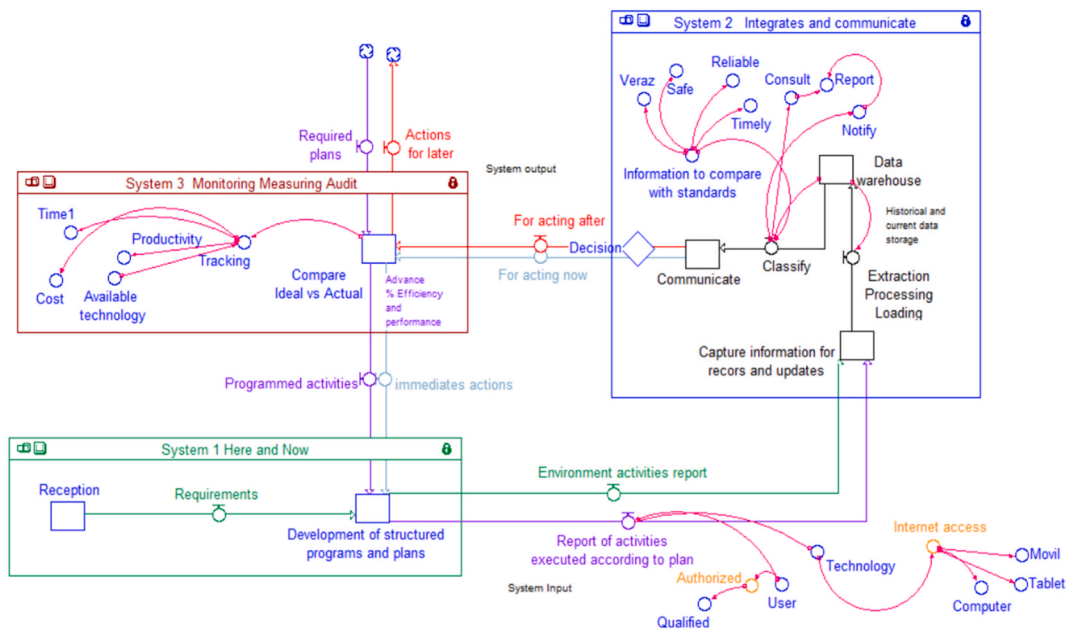

Fig. 13. General detail of system 2 (information system) identifying its inputs and outputs, with system 1 (operational) and system 3 (regulation and control).

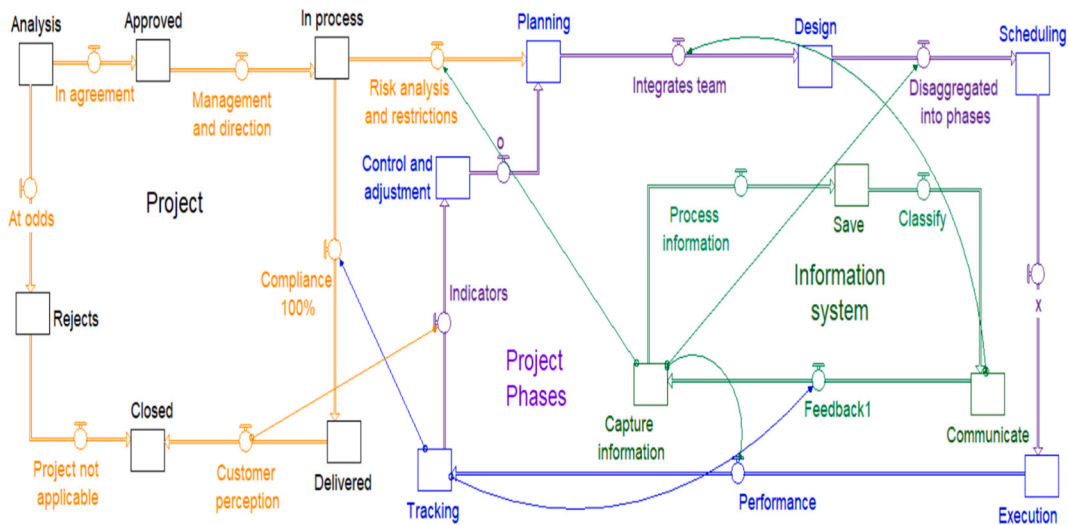

Fig. 14. Relationship between project management (indicating its status and phases) and the intervention of system 2 (information system) during the project life cycle.

[74], and manufacturing [75] sectors. BIM tools have been implemented in construction and integrated into project management. However, they are yet to be explored. The need for more information about this integration represents one reason for its limited use [76]. It is essential to encourage adopting these practices in academic environments, so they can be implemented in organizations that will benefit from the advantages.

This study contributes to improving efficiency of decision-making process based on an information system in a collaborative work environment by integrating BIM, Lean construction, and PLM methodologies. This systemic relationship of methodologies is relevant due to the compatibility of the structure, purpose they pursue individually, and the fact that they do not get the maximum benefit in their individual state. The project management benefits the initial stages (idea) as the concluding stages (ultimate disposition of the construction) by integrating its life cycle and involving all the collaborators from the same channel.

The findings of this study indicate that information systems should not be managed in isolation. They support project management provided by other systems such as essential operations, monitoring through indicators and standards, strategic planning of activities,

institutional policies, and values system for decision-making. All these systems are affected by an external environment, that is directly related to the basic operating system. If it requires direct attention or the strategic planning system does, the response must be structured to provide a solution in the future.

Additionally, this study reveals that information represents a crucial part of the integration process. It requires a substantial degree of quality, determined by its level of truthfulness, accuracy, integrity, and reliability, and it must be available according to the user's interest.

Consequently, the general review of the literature on construction project management must improve its results in time and form. The application of traditional or the most recent methodologies accompanied by lack of integration of the participants from the primary stages do not provide the best result. This research's objective was to propose a new way of approaching integral project management, directly integrating the participatory, communicative components based on continuous information flow through systems that warrant it.

On the other hand, integrating variables through effective communication channels offers attributes that equally represent the principal value of this research to academic, management, and policy perspectives for project management in the construction sector.

From the management and policy area:

Strengthens a Collaborative work environment.

Gives importance and relevance to the preservation of information, also guaranteeing its significant quality.

Keeping in mind the effects of the micro and macro environment surrounding the project.

Establishing links with other systems.

Strengthening from the digitalization of the flexible standardization of the processes.

Availability and security of information for decision-making throughout the project's life cycle.

Project coordinators and managers have an alternative for approaching their work, this time in a global way, considering elements that were previously ignored because they did not conceive a holistic idea of the process but rather fragmented individual parts that had to be adapted. Even if that meant delays and severe costs in the middle of the execution. By applying our proposed abstract model, the team is integrated from the initial to the concluding phase, being aware that each action or decision affects others' work.

Fundamental aspects such as information flow, communication, and active collaborative environment among project members from primary stages provide significant change in the way of managing projects. It is necessary to break paradigms, open minds, and transform the current procedural and cultural structures [7]. For the academy is an opportunity to design integral training processes in certain areas of study. So, they are encouraged to apply it to other sectors and learning management tools, even if they are unspecific to the area.

From the academic field, interdisciplinarity is highlighted, from the extra-polarization of tools from other areas of study. Such as migrating from manufacturing or aeronautical environments to construction due to the success stories where those sectors improved their results in terms of management of their operations thanks to standardization and digitization. The latter is one of the most challenging operations for professionals. Combining the necessary variables to obtain results in time and form represents a non-fundamental task. This task needs tools to strengthen its activity based on information and integration of teamwork from a systemic scope.

5.1. Limitations and future research

As this is a conceptual model, it is necessary to verify its accuracy through validation of the integration model. So, we would know the level of contribution in the sector with more solid criteria. On the other hand, considering it as future research, it is essential to deepen the environmental impact that this integration of methodologies may cause. A favorable result is expected because Lean contributes to the adequate and appropriate use of resources, BIM allows better accuracy of the requirements in terms of materials before use, and this application is relevant at each stage of the project, i.e., throughout its life cycle. So, the effect on the environment would be minimal in terms of negative impacts.

Data availability

All data generated or analyzed during this study are included in this published article.

CRedit authorship contribution statement

Luis P. León-Romero: Writing – review & editing, Writing – original draft, Methodology, Investigation, Funding acquisition, Formal analysis, Conceptualization. **Mario Aguilar-Fernández:** Methodology, Funding acquisition, Formal analysis, Conceptualization. **Amalia Luque-Sendra:** Validation, Formal analysis. **Francisco Zamora-Polo:** Validation, Supervision, Formal analysis. **Misaela Francisco-Márquez:** Supervision, Investigation, Funding acquisition, Formal analysis, Conceptualization.

Declaration of competing interest

The authors declare that they have no known competing financial interests or personal relationships that could have appeared to

influence the work reported in this paper.

Acknowledgments

We gratefully thank the CONAHCYT for the scholarship and Secretaria de Investigación of Instituto Politécnico Nacional (IPN) for making possible the mobility to Luvis Paola Leon-Romero in the master program. We thank the SNI of CONACHYT, the EDI and PEDD scholarships (Both from the IPN). This work has been supported by the GOYA - Antonio Unanue in Engineering in the Agrifood Industry Chair of the University of Seville (Spain) and the VII Own Research and Transfer Plan 2023 of the University of Seville (Projects 2023/0000378 and 2023/00000390).

References

- [1] A.V. Peralta, A. Serpell, Características de la Industria de la Construcción, *Revista Ingeniería de Construcción*. 11 (1991) 5–22.
- [2] L. Li, J. Yuan, M. Tang, Z. Xu, W. Xu, Y. Cheng, Developing a BIM-enabled building lifecycle management system for owners: architecture and case scenario, *Autom. Construct.* 129 (2021), <https://doi.org/10.1016/j.autcon.2021.103814>.
- [3] F. Zamora-Polo, M.M. Sánchez-Cortés, A.M. Reyes-Rodríguez, J.G. Sanz-Calcedo, Developing project managers' transversal competences using building information modeling, *Appl. Sci.* 9 (2019), <https://doi.org/10.3390/app9194006>.
- [4] H. Hernández, *Modelado Computacional de la Dinámica del Desempeño en Proyectos de Construcción*, 2006, pp. 1–97.
- [5] R. Mejía-Gutiérrez, C. Marroquín, J. Giraldo, Product lifecycle management (PLM) as a strategy for project structuring and coordination. 17th International Congress on Project Management and Engineering, 2013, pp. 104–116.
- [6] M.M.M. Teo, M. Loosemore, A Theory of Waste Behavior in the Construction Industry, *Construction Management and Economics*, vol. 19, 2001, pp. 741–751, <https://doi.org/10.1080/01446190110067037>.
- [7] M. Ángel Álvarez, A. Bucero, C.J. Pampliega, Integrated Project Delivery, an alternative to the usual form of construction work in Spain, *Building & Management* 1 (2017) 30–36. http://polired.upm.es/index.php/building_management/.
- [8] L. Rischmoller, L.F. Alarcón, L. Koskela, Improving value generation in the design process of industrial projects using CAVT, *J. Manag. Eng.* 22 (2006) 52–60.
- [9] J. Pons, I. Rubio, *Colección Guías Prácticas de Lean Construction. Lean Construction y la Planificación colaborativa. Metodología Last Planner System*, 1a Edición, Consejo General de la Arquitectura Técnica de España, 2019.
- [10] R. Sacks, L. Koskela, B.A. Dave, R. Owen, Interaction of lean and building information modeling in construction, *J. Construct. Eng. Manag.* 136 (2010) 968–980, [https://doi.org/10.1061/\(asce\)co.1943-7862.0000203](https://doi.org/10.1061/(asce)co.1943-7862.0000203).
- [11] A. Latorre, C. Sanz, B. Sanchez, Application of lean-BIM model to improve design building phase's productivity, *Inf. Construcción* 71 (2019) 1–9, <https://doi.org/10.3989/ic.67222>.
- [12] S.Y. Eroshkin, N.D. Koryagin, D. V Kovkov, D. V Panov, A.I. Sukhorukov, The Paradigm of the Integration of Different Types of Management Information Systems in Investment and Construction Company Implementing the Project Approach, Elsevier B.V., 2017, pp. 605–608, <https://doi.org/10.1016/j.procs.2017.01.076>.
- [13] Patrick Hoverstadt, *The Fractal Organization: Creating Sustainable Organizations with the Viable System Model*, John Wiley & Sons, 2008.
- [14] M. Aguilar Fernández, J. Patiño Ortiz, B.G. Jarquín, P. Fortanell Estrada, J.A.Á. Cedillo, The viable systems model: a literature review, *International Journal of Latest Research in Science and Technology* 10 (2021) 34–36, <https://doi.org/10.29111/ijlrst-2019-10968>.
- [15] Project Management Institute, *The Standard for Project Management and a Guide to the Project Management Body of Knowledge (PMBOK Guide)*, sixth ed., 2017.
- [16] G. Oussouboure, R. Delgado, La Asignación de Recursos en la Gestión de Proyectos Orientada a la Metodología BIM, *Revista de Arquitectura e Ingeniería*. 11 (2017) 1–11.
- [17] K. Muruganandan, A. Davies, J. Denicol, J. Whyte, The dynamics of systems integration: balancing stability and change on London's Crossrail project, *Int. J. Proj. Manag.* 40 (2022) 608–623, <https://doi.org/10.1016/j.ijproman.2022.03.007>.
- [18] C. Wang, Y. Tang, Y. Mo, M.M. Huang, H. Abdul-Rahman, Structured mathematical modelling on innovation management in project-oriented small construction firms, *Heliyon* 9 (2023) e13386, <https://doi.org/10.1016/j.heliyon.2023.e13386>.
- [19] G.J.F. Pérez Gómez Martínez, H.Y. Del Toro Botello, A.M. López Montelongo, Mejora en la construcción por medio de lean construction y building information modeling: caso estudio, *Revista de Investigación En Tecnologías de La Información* 7 (2019) 110–121, <https://doi.org/10.36825/riti.07.14.010>.
- [20] A. Luque, A.D. Las Heras, M.J. Ávila-Gutiérrez, F. Zamora-Polo, ADAPTS: an intelligent sustainable conceptual framework for engineering projects, *Sensors* 20 (2020), <https://doi.org/10.3390/s20061553>.
- [21] J. Tian, G. He, Research on the construction of a collaborative ability evaluation system for the joint graduation design of new engineering specialty groups based on digital technology, *Heliyon* 9 (2023) e16855, <https://doi.org/10.1016/j.heliyon.2023.e16855>.
- [22] B. Hickey, D.C. Gachon, D.J. Cosgrove, Digital twin – a tool for project management in manufacturing, *Procedia Comput. Sci.* 217 (2023) 720–727, <https://doi.org/10.1016/j.procs.2022.12.268>.
- [23] A. Ramón-Elizondo, R. Barboza-Arguedas, Uso de la simulación en procesos de construcción. *Revista Tecnología En Marcha*, 2019, <https://doi.org/10.18845/tm.v32i4.4799>.
- [24] M. Rojas, N. Marín, A. Vila, Aplicación de las TICs en el Ámbito de la Construcción, *Iniciación a La Investigación*, *Revista Electrónica Universidad de Jaén* 5 (2013) 1–9.
- [25] H. Luo, L. Lin, K. Chen, M.F. Antwi-Afari, L. Chen, Digital technology for quality management in construction: a review and future research directions, *Developments in the Built Environment* 12 (2022), <https://doi.org/10.1016/j.dibe.2022.100087>.
- [26] A. Martín, F. Aguayo, J. Lama, A. Córdoba, *Modelo Dinámico para la Gestión Integrada de Proyectos de Construcción*, XVI Congreso Internacional de Ingeniería de Proyectos (2012) 403–414.
- [27] O. Kammouh, M. Nogal, R. Binnekamp, A.R.M. Wolfert, Dynamic control for construction project scheduling on-the-run, *Autom. Construct.* 141 (2022), <https://doi.org/10.1016/j.autcon.2022.104450>.
- [28] F. Amer, M. Golparvar-Fard, Modeling dynamic construction work template from existing scheduling records via sequential machine learning, *Adv. Eng. Inf.* 47 (2021), <https://doi.org/10.1016/j.aei.2020.101198>.
- [29] M. Nabawy, L.M. Khodeir, A systematic review of quantitative risk analysis in construction of mega projects, *Ain Shams Eng. J.* 11 (2020) 1403–1410, <https://doi.org/10.1016/j.asej.2020.02.006>.
- [30] Pajares J., Acebes F., Poza D., Martín-Cruz N., Lopez-Paredes A., Managing project complexity, *Contributions from Systems Thinking*, 26 Th International Congress on Project Management and Engineering Terrassa (2022) 118-129.
- [31] H. Mikkelsen, J.O. Riis, *Project Management: A Multi-Perspective Leadership Framework*, 2017.
- [32] A.A. Fashina, M.A. Omar, A.A. Sheikh, F.F. Fakunle, Exploring the significant factors that influence delays in construction projects in Hargeisa, *Heliyon* 7 (2021) e06826, <https://doi.org/10.1016/j.heliyon.2021.e06826>.
- [33] A. Patel, A. Shelake, A. Yadhav, Sustainable construction by using novel frameworks using BIM, LEED, and Lean methods, *Mater Today Proc* (2023), <https://doi.org/10.1016/j.matpr.2023.02.238>.
- [34] F. Zamora-Polo, A. Luque-Sendra, F. Aguayo-González, G. González, Conceptual framework for the use of building information modeling in engineering education, *Int. J. Eng. Educ.* 35 (2019) 744–755.

- [35] Ö. Çimen, Development of a circular building lifecycle framework: inception to circulation, *Results in Engineering* 17 (2023), <https://doi.org/10.1016/j.rineng.2022.100861>.
- [36] S. Rokoeei, Building information modeling in project management: necessities, challenges and outcomes, *Procedia Soc Behav Sci* 210 (2015) 87–95, <https://doi.org/10.1016/j.sbspro.2015.11.332>.
- [37] B. Dave, S. Boddy, L. Koskela, Challenges and Opportunities in Implementing Lean and BIM on an Infrastructure Project, *Lean with IT*, 2013, pp. 741–750.
- [38] L. Alarcón, E. Pellicer, *La producción sin pérdidas aplicada a la construcción*, 2009.
- [39] E.L. Jacobsen, N.S. Strange, J. Teizer, Lean construction in a serious game using a multiplayer virtual reality environment, in: *IGLC 2021 - 29th Annual Conference of the International Group for Lean Construction - Lean Construction in Crisis Times: Responding to the Post-Pandemic AEC Industry Challenges*, Department of Engineering, Civil Engineering Division, Pontificia Universidad Católica del Perú, 2021, pp. 55–64, <https://doi.org/10.24928/2021/0160>.
- [40] A. Khanzode, M. Fischer, D. Reed, G. Ballard, *A Guide to Applying the Principles of Virtual Design & Construction (VDC) to the Lean Project Delivery Process*, 2006.
- [41] E.N. Shaqour, The impact of adopting lean construction in Egypt: level of knowledge, application, and benefits, *Ain Shams Eng. J.* 13 (2022), <https://doi.org/10.1016/j.asej.2021.07.005>.
- [42] W. Al Balkhy, R. Sweis, Z. Lafhaj, Barriers to adopting lean construction in the construction industry—the case of Jordan, *Buildings* 11 (2021), <https://doi.org/10.3390/buildings11060222>.
- [43] E. Placer, Tesis Doctoral: *Vigilancia Tecnológica y Procesos de Gestión de la Información como Factores Claves para la Innovación en PYMES*, 2016.
- [44] J. Stark, *Decision Engineering Product Lifecycle Management Volume 1: 21st Century Paradigm for Product Realization*, third ed., third ed., Springer, 2015 <https://doi.org/10.1007/978-3-319-17440-2>.
- [45] C. Vila, D. Ugarte, J. Ríos, J. V. Abellán, Project-based collaborative engineering learning to develop Industry 4.0 skills within a PLM framework, *Procedia Manuf.* 13 (2017) 1269–1276, <https://doi.org/10.1016/j.promfg.2017.09.050>.
- [46] A. Saaksvouri, A. Immonen, *Product Lifecycle Management*, third ed., Springer, 2008.
- [47] M. Agost, F. Romero, P. Company, C. Vila, *Aplicación de Utilidades PLM para la Gestión de Proyectos colaborativos de Desarrollo de Nuevos Productos*, X Congreso Internacional de Ingeniería de Proyectos, 2006, pp. 903–994.
- [48] M. Kliment, R. Popovič, J. Janek, Analysis of the Production Process in the Selected Company and Proposal a Possible Model Optimization through PLM Software Module Tecnomatix Plant Simulation, Elsevier Ltd., 2014, pp. 221–226, <https://doi.org/10.1016/j.proeng.2014.12.147>.
- [49] J. Sauza Bedolla, F. Ricci, J. Martínez Gómez, P. Chiabert, Fostering PLM implementation in SMEs: modelling and managing verification processes, in: *IFAC Secretariat*, 2013, pp. 1762–1767, <https://doi.org/10.3182/20130619-3-RU-3018.00489>.
- [50] S. Rashidian, R. Drogemuller, S. Armani, The compatibility of existing BIM maturity models with lean construction and integrated project delivery, *J. Inf. Technol. Construct.* 27 (2022) 496–511, <https://doi.org/10.36680/j.itcon.2022.024>.
- [51] B. Dave, V. Oy, L.J. Koskela, Analysis framework for the interaction between lean construction and Building Information Modelling, in: *17th Annual Conference of the International Group for Lean Construction*, 2009, pp. 221–234. <https://www.researchgate.net/publication/45622276>.
- [52] P. Oskouie, D.J. Gerber, T. Alves, B. Becerik-Gerber, Extending the interaction of building information modeling and lean construction, in: *20th Annual Conference of the International Group for Lean Construction*, 2012.
- [53] J.R. Jupp, V. Singh, Similar concepts, distinct solutions, common problems: learning from PLM and BIM deployment, *International Federation for Information Processing (2014)* 31–40.
- [54] R. Harik, L. Rivest, A. Bernard, B. Eynard, A. Bouras, Product lifecycle management for digital transformation of industries. <http://www.springer.com/series/6102>, 2016.
- [55] P. Chiabert, A. Bouras, F. Noël, Ríos José, product lifecycle management to support industry 4.0. <https://doi.org/10.1007/978-3-030-01614-2>, 2018.
- [56] G. Mangialardi, C. Di Biccari, C. Pascarelli, M. Lazoi, A. Corallo, BIM and PLM Associations in Current Literature, Springer New York LLC, 2017, pp. 345–357, https://doi.org/10.1007/978-3-319-72905-3_31.
- [57] V. Gecevška, I. Veza, N. Stefanic, Lean PLM-information technology strategy for innovative and sustainable business environment, *International Journal of Industrial Engineering and Management (IJEM)* 3 (2012) 15–23. www.iim.ftn.uns.ac.rs/ijem_journal.php.
- [58] T. Stojanov, V. Gecevška, Z. Anisic, Lean product lifecycle management approach, *International Journal of Industrial Engineering and Management (IJEM)* 4 (2013) 207–214. www.iim.ftn.uns.ac.rs/ijem_journal.php.
- [59] N. El Faydy, L. El Abbadi, Interpretive structural modelling of critical success factor for lean product lifecycle management in industry 4.0, *International Journal of Production Management and Engineering* 11 (2023) 65–72, <https://doi.org/10.4995/ijpme.2023.18840>.
- [60] E.F. Nada, E.A. Laila, Interpretive structural modeling of critical success factors for lean PLM implementation, *Journal of System and Management Sciences* 12 (2022) 74–86, <https://doi.org/10.33168/JSMS.2022.0304>.
- [61] V. Malla, Structuration of lean-agile integrated factors for construction projects, *Construct. Innovat.* (2023), <https://doi.org/10.1108/CI-05-2022-0105>.
- [62] R.L. Owen, L. Koskela, *Agile Construction Project Management*, Greater Manchester, 2006.
- [63] P. Checkland, J. Scholes, *La Metodología de los sistemas suaves de acción*, first ed., Noriega Editores, México, 1994.
- [64] P. Checkland, J. Poulter, *Soft systems methodology. Método Radical para Integrar Actividades Organizativas*, 2010.
- [65] John Sterman, *Business Dynamics: Systems Thinking and Modeling for a Complex World*, Irwin/McGraw-Hill, 2000.
- [66] M.D. Rojas López, C.R. Arango, L. Bastidas, Modelamiento del ciclo de la construcción en Colombia mediante dinámica de sistemas, *Revista Ingenierías Universidad de Medellín* 15 (2016) 43–62, <https://doi.org/10.22395/rium.v15n29a3>.
- [67] S. Cummings, J. Brocklesby, J. Davies, Demystifying the viable system model as a tool for organizational analysis, *Asia-Pacific Journal of Operational Research* 12 (1995) 65–86.
- [68] Barry. Richmond, Inc, *High Performance Systems, an Introduction to Systems Thinking: Ithink Software, High Performance Systems*, 2001.
- [69] S. Aram, C. Eastman, Integration of PLM solutions and BIM system for the AEC industry, in: *The International Association for Automation and Robotics in Construction*, 2013, pp. 1046–1055, <https://doi.org/10.22260/ISARC2013/0115>.
- [70] F. Blampain, M. Bricogne, B. Eynard, C. Bricogne, S. Pinon, Digital Thread and Building Lifecycle Management for Industrialization of Construction Operations: A State-Of-The-Art Review, Springer Science and Business Media Deutschland GmbH, 2023, pp. 884–894, https://doi.org/10.1007/978-3-031-15928-2_77.
- [71] C. Boton, L. Rivest, D. Forgues, J. Jupp, Comparing PLM and BIM from the Product Structure Standpoint (2016) 443–453, https://doi.org/10.1007/978-3-319-54660-5_40i.
- [72] A. Eldeep, M. Farag, L.M. Abd El-hafez, Using BIM as a lean management tool in construction processes – a case study: using BIM as a lean management tool, *Ain Shams Eng. J.* 13 (2022), <https://doi.org/10.1016/j.asej.2021.07.009>.
- [73] D. Silva, K.L. De Jesus, B. Villaverde, A.I. Enciso, A.N. Mecija, J.O. Mendoza, Interdisciplinary Framework: A Building Information Modeling Using Structural Equation Analysis in Lean Construction Project Management, IOS Press BV, 2021, pp. 234–240, <https://doi.org/10.3233/FAIA210253>.
- [74] A.J. Likita, M.B. Jelodar, V. VishnuPriya, J.O.B. Rotimi, N. Vilasini, Lean and BIM implementation barriers in New Zealand construction practice, *Buildings* 12 (2022), <https://doi.org/10.3390/buildings12101645>.
- [75] D.J. Gerber, B. Becerik-Gerber, A. Kunz, Building information modeling and lean construction: technology, methodology and advances from practice, in: *Haifa*, 2010, pp. 1–11. <https://www.researchgate.net/publication/278667977>.
- [76] R. Navarro, A. Tiwari, C. Turner, Improving product lifecycle management implementations by applying “lean” principles, *Int. J. Prod. Lifecycle Manag.* 6 (2013) 357–380, <https://doi.org/10.1504/IJPLM.2013.063212>.