



BMJ Open Economic evaluation of a novel genetic screening test for risk of venous thromboembolism compared with standard of care in women considering combined hormonal contraception in Switzerland

C Simone Sutherland,¹ Zanfina Ademi,^{1,2} Joëlle Michaud,³ Nadine Schur,¹ Myriam Lingg,¹ Arjun Bhadhuri,¹ Thierry D. Pache,⁴ Johannes Bitzer,⁵ Pierre Suchon,^{6,7} Valerie Albert ,⁸ Kurt E. Hersberger ,⁸ Goranka Tanackovic,³ Matthias Schwenkglens¹

To cite: Sutherland CS, Ademi Z, Michaud J, *et al.* Economic evaluation of a novel genetic screening test for risk of venous thromboembolism compared with standard of care in women considering combined hormonal contraception in Switzerland. *BMJ Open* 2019;**9**:e031325. doi:10.1136/bmjopen-2019-031325

► Prepublication history and additional material for this paper are available online. To view these files, please visit the journal online (<http://dx.doi.org/10.1136/bmjopen-2019-031325>).

Received 14 May 2019

Revised 04 October 2019

Accepted 08 October 2019



© Author(s) (or their employer(s)) 2019. Re-use permitted under CC BY-NC. No commercial re-use. See rights and permissions. Published by BMJ.

For numbered affiliations see end of article.

Correspondence to

Dr C Simone Sutherland;
simone.sutherland@unibas.ch

ABSTRACT

Aim The aim of this study was to assess the cost effectiveness of the Pill Protect (PP) genetic screening test for venous thromboembolism (VTE) risk compared with standard of care (SoC), for women considering combined hormonal contraceptives (CHCs) in Switzerland.

Methods A two-part microsimulation model was developed to estimate VTE events, costs and quality-adjusted life years (QALYs) associated with the PP and SoC strategies. In the first portion of the model, a cohort of 1 million Swiss first-time seekers of a CHC were simulated. It was determined whether each woman would receive a CHC or non-CHC by using prescribing patterns elicited from a modified Delphi study. These results formed the basis of the SoC strategy. For the PP strategy, a PP test was included and the results considered in addition to SoC practice. Each woman then entered a Markov model that captured morbidity and mortality over a lifetime. The risk of having a VTE was derived from the risk algorithm that underpins the PP test. The remaining model inputs relating to population characteristics, costs, health resource use, mortality and utilities were derived from published studies or national sources. The model was validated and calibrated to align with population-based studies. Extensive uncertainty analyses were conducted.

Results From a Swiss health system perspective, the PP strategy in comparison with the SoC strategy generated an additional CHF 231, and gained 0.003 QALYs per woman, leading to an incremental cost-effectiveness ratio of CHF 76 610 per QALY gained. Assuming a threshold of CHF 100 000 per QALY gained, the PP strategy is likely to be cost effective. Our results were generally robust to variations in the parameter values.

Conclusions The PP test may be cost effective in Switzerland for screening women seeking CHCs for their risk of VTE based on the current evidence.

Strengths and limitations of this study

- We used advanced quantitative methods to appropriately model the long-term costs and effects of the strategies compared.
- In addition, we undertook primary qualitative research through a modified Delphi study to inform the pathway of SoC patients through the model.
- The model was calibrated and validated to accurately predict estimates of venous thromboembolism using published data from European cohort studies.
- Extensive sensitivity and scenario analyses were undertaken to test the robustness of the results.
- Limitations are that our clinical and cost-effectiveness results are dependent on the accuracy of Pill Protect to predict the occurrence of venous thromboembolism events (which has been validated retrospectively but not yet prospectively or externally), and the hypothesis that all Swiss clinicians behave as assessed by our modified Delphi study.

INTRODUCTION

The development of the contraceptive ‘pill’ began in the 20th century and gained popularity due to its benefits in controlling menstrual bleeding and as a simple and effective family planning mechanism.^{1 2} The combination of ethinyl estradiol (EE) and various progestins has become the basis for combined (hormonal) oral contraceptives. Combined hormonal contraceptives (CHCs) comprise oral pills and other contraceptive devices (ie, rings or patches) that contain oestrogen in combination with a progestogen.

Venous thrombosis is a serious medical condition that occurs when a blood clot

(thrombus) forms in one or more veins of the body. One particular form of venous thrombosis is called deep vein thrombosis (DVT). Here, the blood clot occurs in deep veins, typically of the legs. Such blood clots may travel through the bloodstream and lodge in lungs, where they can block blood flow, causing pulmonary embolism (PE). The term, venous thromboembolism (VTE), incorporates both conditions of DVT and PE.³ The incidence of VTE increases with age from 1:100 000 in children per year to 1:10 000 for individuals per year in the reproductive age, and finally to 1:1000 individuals per year at the age of 50–60.⁴ All ages included, the disease occurs in 1–2 per 1000 individuals per year.⁵ The association between dosage of EE in CHCs and VTE has been known since 1970,¹⁶ and recent studies show that VTE risk in CHC users is 3–18 times higher than for non-users according to the hormonal combination underlying the CHC.⁷

Genetic studies have identified many variations associated with the development of VTE.⁸ Among them are variations in Factor V Leiden⁹ and Factor II G20210 (also known as prothrombin)¹⁰ or deficiencies in C and S proteins. In addition, VTE is a multifactorial disease influenced by genetic factors but also by behavioural and environmental factors such as smoking status and hormonal treatment. Several studies have developed algorithms to estimate thrombosis risk according to an individual's clinical and/or genetic profile,¹¹ but few have estimated this for CHC users specifically. The field of personalised medicine tailored to people's genetic profiles by using specific algorithms is expected to expand in the next decades following recent initiation into Swiss clinical practice. Personalised approaches could be used to inform patients about their risk of VTE. For many first-time seekers of CHCs, genetic testing may flag up an increased VTE risk associated with a CHC prescription which exceeds the benefits and for which alternative contraceptive methods exist.

The Swiss Society of Gynaecology and Obstetrics (SSGO) guidelines and published recommendations¹² suggest that clinicians assess thrombosis risk in patients and only prescribe CHCs for those with low or no apparent thrombogenic risk. However, women often do not know their medical or family history and clinicians make qualitative judgements of when the combined risks of CHCs exceed the benefits.

The Pill Protect (PP) algorithm was developed and validated using published PILL Genetic Risk Monitoring and Cohort Lausanne cohorts.¹³ The algorithm quantifies a CHC user's VTE risk according to her genetic and behavioural characteristics. Retrospective validation results showed the algorithm successfully predicted thromboembolic events for oral contraceptive users (area under the receiver operator characteristic curve=0.71, 95% CI 0.69 to 0.74). The algorithm underlies the PP genetic test currently reimbursed in Swiss clinical practice under certain conditions for health providers. Although several alternative tests evaluating clinical and genetic

thrombosis risk exist, only PP assesses VTE risk related directly to CHC use.

Recent reviews of the literature have found scarcity of economic evaluations for screening genetic risk of VTE in first-time CHC users.^{14 15} Furthermore, most of the studies were based on short-term decision tree models, although a personalised microsimulation model may be a more appropriate specification.¹⁶ This is the first study to assess clinical, quality of life, cost outcomes and cost-effectiveness of the PP test when screening first-time seekers of CHCs at risk of VTE in comparison to the Swiss standard of care (SoC).

METHODS

We developed an individual sampling model simulating VTE and other clinical events occurring over the lifetime of each woman based on her personal characteristics (using Swiss and European prevalence data) and the contraceptive method recommended to her. One million women were simulated, and the model was populated with inputs derived from literature searches, national databases, local pharmacies and expert opinion from a modified Delphi study that we conducted. The model calculated annual outcomes for costs, VTEs, life years gained and quality-adjusted life years (QALYs) gained. Perspectives of cost assessed included a Swiss health system perspective considering direct medical costs irrespective of payer (base-case analysis), a health insurer perspective only considering reimbursement by insurers within the framework of the Swiss statutory health insurance (45% of inpatient services, 100% of drug treatment and PP test costs, 50% of laboratory fees and 0% of contraceptive interventions) and a societal perspective including all direct costs and productivity costs.

A lifetime time horizon (maximum of 85 years since model entry) was used for the model and considered appropriate as single and recurrent VTE events often occur in the longer term and may have long-term consequences. However, the model does not take into consideration that early detection of genetic risk for thrombosis might lead to prophylactic treatments later in life, except for the choice of contraception method. A discount rate of 3% for costs and outcomes was applied as is typical for Swiss economic evaluation.¹⁷

Population, intervention, comparator, outcomes and setting

Our analysis targeted Swiss women aged 15–29 years, as this was the age range of potential first-time users seeking CHCs elicited from the modified Delphi study described in the 'strategy description'. The comparator was the Swiss SoC also described in strategy description, while the intervention incorporated the PP test into SoC. The setting was Switzerland, and the following outcomes were reported: VTEs, mortality, life years gained, QALYs, costs and cost per QALY gained.

Strategy description

Schematic diagrams of the SoC and PP clinical pathways are illustrated in [figure 1](#). For both SoC ([figure 1A](#)) and

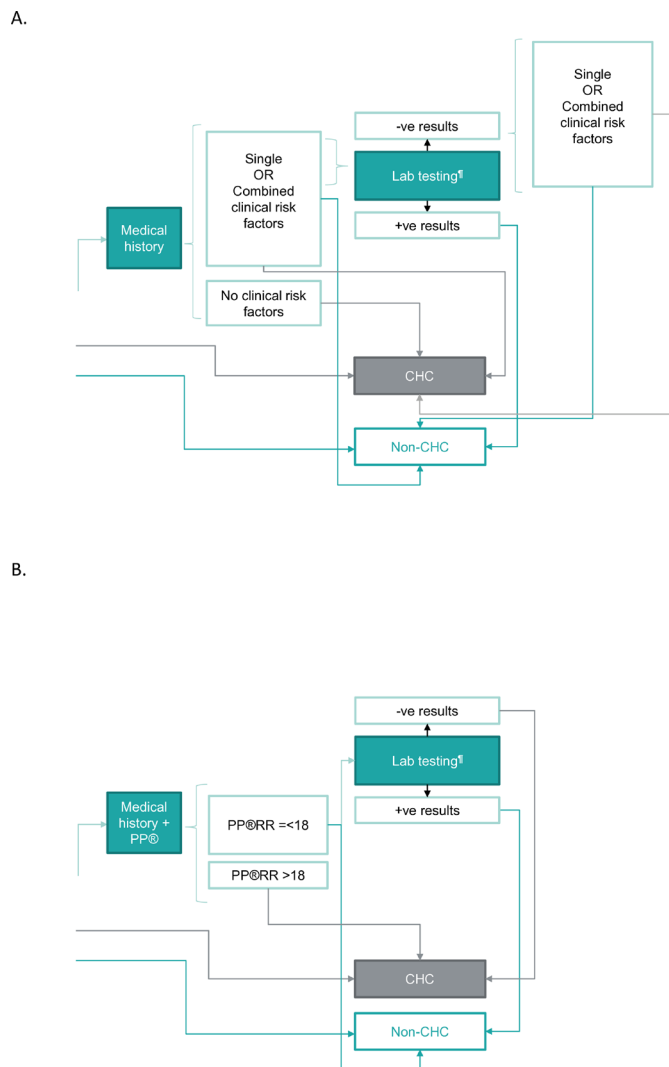

Figure 1 (A) Clinical decision algorithm and resulting possible pathways, standard of care. (B) Clinical decision algorithm and resulting possible pathways, Pill Protect (PP); CHC, combined hormonal contraceptives; RR, relative risk.

PP (figure 1B), the first step for the clinician is to review the woman's medical history and subsequently recommend an alternative to CHCs (such as progestin-only pills, condoms, diaphragms or sponges), or prescribe a CHC. However, for the PP strategy, the first step also includes the completion of the PP test (refer to figure 1B), and if the test indicates high relative risk (RR) of VTE, a non-combined contraceptive is recommended. Otherwise, patients are automatically prescribed a CHC unless they have a positive family history of thrombosis in which case additional thrombophilia testing takes place and the result of this determines prescription of either a CHC or non-combined contraceptive. A threshold of 18 was established for a high RR of VTE; it was chosen because it is very close the highest naturally occurring risk in a woman's lifetime (during the postpartum period).

We determined characteristics of SoC in practices of Swiss clinicians recommending CHCs, by undertaking a modified Delphi study between 2017 and 2018. We asked

questions to clinicians related to how general practice for recommending CHCs in Switzerland is carried out. Nineteen gynaecologists completed the first round, six the second round (97% agreement) and three participated in a final round used to clarify a few questions where second round consensus was not reached. The results of the Delphi study indicated that clinicians' prescription processes in Switzerland are broadly aligned with SSGO recommendations¹² (refer to online supplementary appendix table A1). Clinicians are cautious in prescribing CHCs to women with apparently high VTE risk, and often seek further biochemical (ie, Protein C, S, lupus anti-coagulants, etc.) and genetic tests (ie, Factors II and V) if positive family history of VTE is present. In addition, they do not prescribe CHCs to women with a confirmed genetic risk (ie, Factor II or V Leiden), and at times avoid CHC prescription in the presence of multiple clinical risk factors (ie, body mass index (BMI), smoking, age), even when genetic testing has confirmed the absence of Factor II G20210A and Factor V Leiden mutations which are known to be contributing to thrombosis risk.

Modelling

We developed a microsimulation model in StataMP V.15 (College Station, TX, USA). Within the model, events occur at an individual level. The simulation of 1 million women seeking prescription of contraception for the first time was generated based on characteristics of age, BMI,¹⁸ smoking status,¹⁹ family history¹³ and nine genetic factors.

The first step in the model simulates each patient through a clinical decision pathway, determined by the strategy (PP or SoC), to establish whether or not a CHC is prescribed based on the patient's baseline characteristics. Once the contraceptive intervention is determined for each individual (CHC or non-combined contraceptive), each woman enters the Markov part of the model for her lifetime. This is done separately for the SoC and PP strategies. The model contains five main health states: no VTE, first VTE, second VTE, post-VTE and death (figure 2). Through this state-transition modelling, costs and utilities associated with each health state are calculated and accrued over the lifetime. Details on the different health states are provided next.

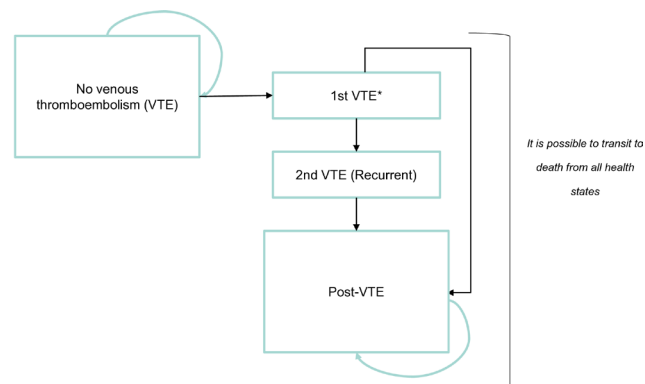

*The Pill Protect® AbsoluteRisk algorithm*coefficient is used to predict the 1st VTE for each woman

Figure 2 Structure of Markov model.



Each woman begins the model without previous VTE event ('no VTE') but is at risk of death or having a first VTE ('first VTE'). If a VTE occurs, the model determines whether it is DVT only or also PE. A patient who survives the VTE then remains in the post-VTE health state for her remaining life (until 'death') or until another VTE event occurs ('second VTE event'). Options for transitions after second VTE mirror those after first VTE, however the event probabilities may differ.

The post-VTE health state comprises women after one or two VTE events. Here, additional morbidity associated with living after VTE is incorporated (table 1). It is assumed CHC use is stopped after a VTE, and contraception switched to a non-combined variety. Costs of contraception continue to incur for the period each woman is estimated to use contraception, determined at baseline in the model. The model is run for each woman up until the point she reaches the 'death' state.

Modelling assumptions

Key modelling assumptions include: the estimates derived from PP algorithm accurately predict relative VTE risk of women with different risk factors. The data obtained from the modified Delphi panel accurately represent actual clinical practice related to contraceptives prescription in Switzerland. Also, we assumed the PP algorithm in combination with appropriate calibration allowed appropriate modelling of real-life occurrence and distribution of VTE events. We also assumed that risks from CHCs were only present while women take CHCs (ie, no spill-over effects) and additional surgery and life events that possibly increase VTE risk did not occur during one's lifetime. We limited the number of recurring VTE events to 'two' at most, and due to lack of evidence, did not incorporate further risk reduction of VTE for those given anti-coagulant prophylaxis (ACP) after VTE.

Validation and calibration

Several modelling calibration and validation exercises were undertaken. Primarily, the model was first designed in Microsoft Excel 2016 and then duplicated in StataMP V.15. Both models produced alike results demonstrating internal validity. In addition, parameters relating to absolute incidence of VTE were calibrated against a Danish cohort study for women aged 15–50 years²⁰ and a Swedish cohort study for women aged over 50.²¹ In order that accurate results in comparison to the cohort studies were produced, we adjusted the VTE incidence parameters estimated from the risk algorithm underlying the PP test,¹³ by an age-related calibration factor. We tested several age-related calibration factors and applied the factor providing results closest to the cohort studies. The weighted-average incidence of VTE in CHC non-users (ages 15–29) was 1.7 per 10000 women years based on the 8-year Danish cohort study.²⁰ Our model predicted a similar VTE incidence in the same age population, of 2.1 per 10000 women years when the model was run for a duration of 8 years. Our slightly higher result was

probably driven by our age distribution, as the median entry age into our model was 21 years; hence, the incidence estimate is similar to those of the same age in the Danish cohort study (ie, ages 20–24; VTE incidence 2.1 per 10000 women years). The median life expectancy simulated by the model was 87 years, which indicates validity as it is close to actual life expectancy of Swiss women (85 years).

Model input parameters

Clinical efficacy, event and population characteristics

Table 1 summarises population, clinical efficacy and event parameters used for the analysis. Parameters relating to population characteristics, BMI and expected duration of CHC use according to age are detailed in online supplementary appendix table A2–A4. The probability that a woman has a first VTE event was calculated using the PP algorithm derived from a study by McDaid *et al*¹³ (for additional calibration to real world data, see above). One of the algorithm components is the RR of having a VTE related to a CHC according to its generation or formulation (ie, second, third, fourth, cyproterone acetate, etc.). This RR of VTE for CHC users compared with non-users was derived from pooled estimates of cohort studies reported by Martinez *et al*.²² RR of VTE for the progestin-only pill and non-hormonal contraception was estimated to be 1.03 (95% CI 0.76 to 1.39) and 1, respectively.

The proportion of VTE events that were DVT and PE were 41.0% and 59.0%, respectively, derived from a USA population study.²³ A Danish database was used to determine that onset of DVT resulted in 1.5% cardiovascular events (myocardial infarction (MI) or stroke) and onset of PE resulted in 1.7% cardiovascular events in the first year.²⁴ Probability of death related to PE and DVT was derived from Italian hospital records.²⁵ To understand recurrence of VTE, a study by Laczkovics *et al* in 2007 was used.²⁶ Mortality for recurrent VTE was assumed to be the same as for first VTE.

Underlying probability of death from general causes is based on Swiss Federal Statistical Office (SFSO) lifetables.

Health-related quality of life (HRQoL)

Table 1 summarises HRQoL values for the model. Utility (preference-based HRQoL) in the female Swiss population is based on a Swiss-specific valuation algorithm.²⁷ Using this algorithm, the microsimulation model calculates age-related utility on an annual basis, and when a VTE event occurs, or a woman remains in post-VTE, the weighted disutility of PE and DVT is applied.

Disutility values after DVT²⁸ and PE²⁸ were derived from Norwegian data. This disutility was applied long term in the post-VTE state as the studies that the values were taken from estimated disutility resulting from DVT/PE for at least 10 years following the event. Disutilities for stroke and MI events were derived from an external study.²⁹

Table 1 Key model inputs

Inputs	Mean estimate (95% CI)	Source
Clinical efficacy and event inputs		
RR of contraceptives		
Second generation: levonorgestrel	3.48 (2.26 to 5.09)	Martinez <i>et al</i> 2012 ²²
Third generation : gestodene, desogestrel	5.65 (3.67 to 8.28)	
Fourth generation: drospirenone, dienogestrel	5.78 (3.05 to 10.61)	
Cyproterone acetate	5.74 (3.74 to 8.39)	
Other (ie, Qlaira)	3.48 (2.26 to 5.09)	
Progestogen only: desogestrel	1.03 (0.76 to 1.39)	Mantha <i>et al</i> 2012 ⁴³
Non-combined: that is, of condoms, IUD, and so on	1	Assumption
Proportion of CHCs		
Second generation: levonorgestrel	47.7% (45% to 50.4%)	Modified Delphi study
Third generation: gestodene, desogestrel	27.0% (24.6% to 29.4%)	
Fourth generation: drospirenone, dienogestrel	17.5% (15.4% to 19.5%)	
Cyproterone acetate	7.1% (6.1% to 8.1%)	
Other (<i>estradiol valerate/dienogest, etonogestrel, chlormadinone acetate</i>)	0.8% (0.5% to 1.1%)	
Proportion of non-CHCs		
Non-CHCs: desogestrel	42.3% (39.4 to 45.2)	Modified Delphi study
Non-CHCs: that is, condoms, contraceptive sponge, and so on	57.7% (49.1 to 66.3)	
VTE-related events		
Proportion of VTE that is DVT alone	41%	Silverstein <i>et al</i> , 1998 ²³
Proportion of VTE that is DVT and PE	59%	
<i>Probability</i>		
DVT leads to MI or stroke	0.015	Sørensen <i>et al</i> , 2007 ²⁴
PE leads to MI or stroke	0.017	
Mortality for PE	0.045 (0.031 to 0.065)	Compagni <i>et al</i> , 2013 ²⁵
Mortality for DVT	0.007 (0.0033 to 0.0128)	
Probability of recurrent VTE	0.0429	Laczkovics <i>et al</i> , 2007 ²⁶
Utility inputs		
<i>Constant</i>	0.84822	Perneger <i>et al</i> , 2010 ²⁷
<i>Age coefficient</i>	0.00208	
<i>Age coefficient2</i>	0.00002	
<i>Gender coefficient*NOTE=1, since female</i>	0.02090	
VTE PE disutility	-0.09	Tavoly <i>et al</i> , 2016 ²⁸
VTE DVT disutility	-0.08	Utne <i>et al</i> , 2016 ²⁸
Disutility stroke	-0.2547	Sullivan <i>et al</i> 2011 ²⁹
Disutility MI (acute)	-0.1690	
Death	0.00	Assumption
Cost inputs		
Consultation costs		
Consultation with clinician for CHC: first visit	CHF 91	TARMED Tarifbrowser 1.08 (22.001), ³² Modified Delphi study
Consultation with clinician for CHC: second visit	CHF 91	TARMED Tarifbrowser 1.08 (22.001) ³²
Third visit (if labs required)	CHF 91	

Continued

Table 1 Continued

Inputs	Mean estimate (95% CI)	Source
PP test	CHF 270	Gene Predictis (oral communication, 21 March 2017)
Laboratory testing		
Laboratory testing for <i>FV Leiden/FII</i> (including administrative and extraction fees)	CHF 616 (553 to 679)	Viollier Switzerland, ⁴⁴ SFOPH, Analysenliste (AL) 2021, 4700, ⁴⁴ Modified Delphi study
Laboratory testing for Protein C, S and Lupus anticoagulant only (including administrative fees)	CHF 185 (241 to 252)	Viollier Switzerland, ⁴⁴ SFOPH, AL, SFOPH, 4700, SFOPH, ⁴⁵ Modified Delphi study
<i>Extraction cost for DNA testing (FV Leiden/FII)</i>	CHF 61	SFOPH, AL 2021 ⁴⁵
<i>Administrative costs for any laboratory testing (added tax)</i>	CHF 24	SFOPH, AL 4700 ⁴⁵
Hospitalisation costs, VTE		
DVT	CHF 6813 (6501 to 7194)	SFSO, ¹⁸ DRG F63 ⁴⁶
PE	CHF 8722 (8499 to 9033)	SFSO, ¹⁸ DRG E64 ⁴⁶
Cardiovascular events related to VTE		
MI	CHF 9141 (8974 to 9401)	SFSO, ¹⁸ DRGs F41, F60 ⁴⁶
Stroke	CHF 13940 (13262 to 13 744)	SFSO, ¹⁸ DRGs B04B, B39, B70 ⁴⁶
Haematologists consultations and visits		
Cost per one outpatient visit (patients require two visits in the first year to manage VTE)	CHF 132	TARMED Tarifbrowser 1.08, 22.002 ³²
Anticoagulant prophylaxis (3 months)	CHF 238	SFOPH, Spezialtaetenliste ³²
CHC generation: progestin contained		
Annual costs		
Second generation: levonorgestrel	CHF 143 (128 to 157)	TopPharm Pharmacies (toppharm Apotheke)
Third generation : gestodene, desogestrel	CHF 169 (152 to 186)	
Fourth generation: drospirenone, dienogestrel	CHF 226 (20 to 249)	
Cyproterone acetate	CHF 170 (153 to 187)	
Other	CHF 302 (263 to 340)	
Non-combined contraceptives		
Progestogen only: desogestrel	CHF 228 (205 to 251)	TopPharm Pharmacies (toppharm Apotheke)
Non-combined alternatives	CHF 177 (159 to 195)	Apotheke HERSBERGER BASEL
Indirect costs		
Productivity loss per disability claim DVT (short term)	CHF 4286 (CHF 2857 to 9183)	SFSO data and expert opinion
Productivity loss per disability claim PE (short term)	CHF 6122 (CHF 2857 to 9183)	SFSO data and expert opinion

CHCs, combined hormonal contraceptives; CHF, Swiss Francs; DRG, diagnosis-related group; DVT, deep venous thrombosis; FII, Factor II; FV, Factor V; IUD, intrauterine device; MI, myocardial infarction; PE, pulmonary embolism; PP, Pill Protect; RR, relative risk; SFOPH, Swiss Faculty of Public Health; SFSO, Swiss Federal Statistical Office; VTE, venous thromboembolism event.

Health resource use and direct costs

Table 1 details cost and resource use values for the model. We selected unit costs in Swiss francs (CHF) and 2016 prices. Costs derived from older sources were inflated to 2016 values using the Swiss Consumer Price Index provided by the SFSO.³⁰ Direct costs related to recommending contraception in Switzerland included

gynaecologist visits and, where applicable, the PP test, thrombophilia tests and further biochemical tests for women with low PP RR scores but positive family history of VTE.

Hospitalisation costs related to a VTE event, stroke or MI were derived from the Swiss diagnosis-related group (DRG) reimbursement database.³¹ Where more than one

DRG was relevant, the weighted average was calculated. Unit costs for haematologist visits for women with a VTE were derived from TARMED,³² and we assumed visit duration of 30 min. Unit costs for drugs with relevant Anatomical Therapeutic Chemical Classification System codes were obtained from the Swiss Federal Office of Public Health Specialty List.³³

Market share data and costs of CHCs were provided by TopPharm Pharmacies in Basel, Switzerland.³⁴ The annual cost for non-combined contraceptives was taken from a weighted average of the costs of condoms, diaphragms, contraceptive sponges and contraceptive pills that only include desogestrel from a Swiss pharmacy (*personal communication, Prof. Hersberger*).

Indirect costs related to productivity losses based on SFSO data^{35–37} and expert opinion were included in the societal perspective. Additional details regarding these calculations are provided in the online supplementary appendix.

One-way sensitivity analysis

We varied all key model input parameters (refer to [table 1](#)) individually using the 95% CI when available or otherwise $\pm 25\%$ of the base-case value.

Probabilistic sensitivity analysis (PSA)

In accordance with Consolidated Health Economic Evaluation Reporting Standards guidelines,³⁸ we included analysis of joint parameter uncertainty through a PSA by running the model using parameter distributions instead of mean values, to generate 1000 simulations. The inputs in the PP algorithm calculating the VTE and the PP RR score, and characteristics related to the population of 1 million women remained fixed, except for the mean estimate of protein C/S prevalence which was assigned a beta distribution. Proportions derived from our modified Delphi study were also assigned beta distributions. Log normal distributions were assigned to RR parameters with the SE of the $\ln(\text{RR})$ calculated from the 95% CI derived from the original studies. For parameters with no available 95% CI, the SE was assumed to be 10% of the mean estimate. Beta distributions were assigned to transition probabilities, and gamma distributions to cost inputs and utility decrements.

Scenario analyses

We investigated 12 scenarios varying key model parameters by running analyses where:

1. Only high-risk individuals, based on the assessment by SGGQ questionnaire (having a family history with two or more clinical risk factors), proceeded through the PP algorithm within the PP strategy.
2. Only low-risk individuals, based on the assessment by SGGQ questionnaire, proceeded through the PP algorithm within the PP strategy.
3. The age of first-time users varied (15–49 years old).
4. The proportion of clinicians who review a woman's medical history was varied. In scenario 4a, it was

assumed that 100% of clinicians considered medical history in the SoC and PP strategies, while scenario 4b assumed 100% of clinicians, in the PP strategy only, considered medical history.

5. We assumed that if more than one clinical risk factor was present, all clinicians did not recommend CHCs.
6. Discount rates varied to 2% and to 5%.
7. Shortened time horizons of 15, 30 and 50 years were evaluated.
8. The PP RR threshold of 18 in the base case varied from 5 to 40.
9. The clinical decision algorithm of 'SoC' was adjusted. For 9a, we assumed that no clinical decision algorithm was applied in the SoC strategy and 100% of SoC women received CHCs, for 9b assumed only second generation CHCs were prescribed if a CHC was recommended; and for 9c assumed no clinical decision algorithm was applied in SoC and 100% of SoC women received a progesterone-only pill.
10. Variations in the market share were applied. For 10a, we based the distribution of CHCs prescribed on Swiss market share data (31% second generation, 38% third generation, 22% fourth generation, 9% cyproterone acetate CHCs). For 10b, 100% of SoC women were given contraception according to a random sampling distribution of Swiss market proportions (17% given non-combined contraception, 26% second generation CHC, 32% third generation, 19% fourth generation, 7.5% cyproterone acetate CHC).
11. We assessed the impact of using the PP test instead of a Factor II or a Factor V test.
12. The CHC duration in 15–19 years old women was assumed to be the maximum possible duration (until 50 years old or occurrence of a VTE).

Patient and public involvement (PPI)

There was no PPI for this study.

RESULTS

Base-case results analysis showed the PP strategy is associated with 21 fewer VTE-related deaths and 669 fewer first VTEs ([table 2](#)) for a population of 1 million women over their lifetime horizon. The PP strategy was also associated with higher costs relative to SoC mostly attributable to the addition of the PP test itself, and more CHC prescriptions ([table 3](#)). These higher costs were to a small part offset by reductions in unneeded thrombophilia laboratory testing, VTE-related hospitalisations and treatments, and prescriptions of non-combined contraceptives which cost more than CHCs in Switzerland. For the PP strategy in comparison with the SoC strategy, base-case cost-effectiveness results indicated slightly higher discounted health system costs of CHF 231 per woman and a gain of approximately 0.003 QALYs per woman, generating an incremental cost-effectiveness ratio (ICER) of CHF 76 610 per QALY gained ([table 4](#)). When the PP strategy

**Table 2** Results: clinical outcomes without discounting, base-case scenario

	SoC	PP	Incremental*
Average LYGs	64.038	64.041	0.002
Average age at death	84.410	84.412	0.002
Persons with CHCs prescribed	733 361	763 705	30 344
Number of first VTEs†	108 026	107 357	-669
VTE-related deaths	3418	3397	-21

*Incremental calculations based on Pill Protect (PP) standard of care (SoC).

†This was estimated over a lifetime (since model entry) and not only during the lifespan when combined hormonal contraceptives (CHCs) are taken.

LYG, life years gained; VTE, venous thromboembolism event.

was assessed from the societal and health insurer perspectives, ICERs of CHF 75 229 and 84 624 per QALY gained were generated, respectively.

The key input parameters in the model were varied individually in one-way sensitivity analyses (online supplementary appendix figure A1). None of these variations resulted in an ICER over CHF 100 000 per QALY. Assessment of the parameters with the biggest impact on cost effectiveness show that reducing the proportion of clinicians who conduct a medical history assessment before prescribing a CHC had the biggest impact (online supplementary appendix figure A1).

We conducted 12 scenario analyses (table 5). Scenario 1 indicated that PP was cost effective when targeting only high-risk individuals. On the other hand, PP generated an ICER of CHF 53 708 per QALY gained where high-risk women (with two combined clinical risk factors and/or positive family history of VTE) received a non-combined

contraceptive in any case, and women with no apparent risk were assessed using PP (scenario 2b).

We tested scenarios that were less likely to occur. In scenario 10b, PP was associated with an ICER of CHF 31 138 per QALY gained. Here, clinicians were assumed to prescribe CHCs according to the market share in Switzerland (without considering medical history). Under scenario 12, where women who were first prescribed CHCs during their adolescent years remained on CHCs until 50 years old (unless VTE occurs sooner), PP was associated with an ICER of CHF 28 911 per QALY gained. Under scenario 8 where the PP RR threshold which determines whether the patient undergoes further thrombophilia testing or not was reduced, ICERs close to CHF 50 000 per QALY gained were produced.

In the PSA, we found the probability of PP being cost effective assuming a CHF 100 000 per QALY gained threshold exceeded 99% (figures 3 and 4).

DISCUSSION

We developed an individual sampling model to assess the cost effectiveness of a PP strategy where the PP test is used to inform the prescription of CHCs, with the purpose of reducing overall risks of contraceptive users experiencing VTEs. The PP strategy (PP test combined with SoC) was compared with SoC alone in terms of costs and QALYs accruing over the lifetime of Swiss women aged 15–29 years who are potential first-time users seeking CHCs. The economic evaluation was conducted from the Swiss health system, health insurer and societal perspectives. In the base case, PP generated ICERs of CHF 76 610, 75 229 and 84 624 per QALY gained for the health system, societal and health insurer perspectives, respectively. The results were quite robust across a wide range of sensitivity and scenario analyses. Considering a cost-effectiveness threshold in Switzerland of CHF 100 000 per QALY (tentatively assumed in other Swiss analyses), and if our

Table 3 Results for costs per women (CHF), health system perspective

	Undiscounted			Discounted		
	SoC	PP	Incremental*	SoC	PP	Incremental*
PP	0	270	270	0	270	270
Consultation	182	182	0	182	182	0
Laboratory testing	34	11	-22	34	11	-22
CHCs	1314	1372	57	1085	1132	47
Non-CHCs	579	511	-68	476	421	-55
VTE inpatient	906	900	-6	243	235	-8
VTE treatment (ACP)	26.70	26.53	-0.17	7.16	6.93	-0.23
VTE (MI/stroke)	20.97	20.83	-0.14	5.63	5.44	-0.19
Total costs	3062.67	3293.36	230.69	2032.79	2263.37	231.58

*Incremental calculations based on Pill Protect (PP) standard of care (SoC).

ACP, anticoagulant prophylaxis; CHCs, combined hormonal contraceptives; MI, myocardial infarction; VTE, venous thromboembolism event.

Table 4 Results, cost effectiveness, base-case scenario

	Undiscounted				Discounted			
	SoC	PP	Incremental*	ICER (CHF per QALY)	SoC	PP	Incremental*	ICER (CHF per QALY)
Average QALYs per woman	51.803	51.810	0.007		23.901	23.904	0.003	
<i>Average costs per woman (CHF)</i>								
Health system	3063	3294	231	32 642	2033	2264	231	76 610
Societal	3471	3699	228	32 169	2148	2374	227	75 229
Health insurer	543	799	256	36 147	218	473	255	84 624

*Incremental calculations based on Pill Protect (PP) standard of care (SoC).

CHF, Swiss francs; ICER, incremental cost-effectiveness ratio; QALY, quality-adjusted life year.

main assumptions hold true, the PP strategy may be cost effective for the studied population.

Our results show that many apparently low-risk individuals are in fact at substantial risk, with young women especially affected. The latter is further supported by real-world data that show that substantial number of DVTs related to CHC occur every year in Switzerland³⁹ despite the clinical screening indicated by the modified Delphi study. Furthermore, other publications already indicated that the limited number of genetic tests included in the standard thrombophilia testing (Factor II G20210A variant and Factor V Leiden), as well as the clinical information assessed, are insufficient to reliably estimate risk of DVT (de Haan H.G. *et al*⁴⁰; Suchon P, *et al*.⁴¹

Primarily, we found that the PP test may present value for women ages 15–29 in general, and for individuals perceived as ‘low risk’ with no obvious non-genetic risk factors. Based on the model presented in here (notably scenario 2b), it appears that from the economic and clinical point of view, an effective strategy would be to keep first screening all women through the SSGO questionnaire and then use the PP test to further assess the risk for women that initially appeared to be at ‘low risk’. According to this approach, women that appear at high risk with the questionnaire would be prescribed a non-CHC contraception immediately, while women that appear at ‘low risk’ would then undergo PP testing and potentially additional laboratory testing for Protein S, lupus antigens, and so on (eg, when there is a presence of positive family history and PP results indicate low genetic risk) and would finally be prescribed CHC or non-CHC based on the laboratory results. Second, our scenario analyses also highlighted that the screening of younger women maintains the best values (scenario 3a and b), especially if young women continue to take prescribed CHCs for the duration of their childbearing years (scenario 12).

Another strength of this analysis is that it has incorporated current prescribing patterns in Switzerland by directly eliciting behavioural patterns through a modified Delphi study. This enabled us to model SoC pathways

for recommending CHCs related to age, which generally aligned with SSGO guidelines¹² (which recommend undertaking precautionary measures and additional assessments for patients presenting VTE risk). However, although SSGO guidelines recommend that ‘low’-risk CHCs (second generation) are prescribed, the Delphi experts and market share data indicated that further generations are regularly prescribed instead. The additional benefits associated with further generations may explain this lack of adherence to the SSGO guidelines. Nonetheless, the results demonstrate that the role of clinicians and adherence to guidelines do impact cost effectiveness (scenario 4) and hence understanding prescribing patterns and patient preferences for CHCs will remain to be key in maintaining cost-effective approaches from the Swiss perspective.

Study limitations include assuming PP realistically predicts VTE events and adequately reflects proportional risks from genetic and clinical risk factors, and assuming the SoC pathway in the model realistically represents real clinical practice in Switzerland. The PP algorithm has been developed and validated retrospectively in a cohort comprising about 800 women who developed VTE while using CHCs and a similar number of controls who were also CHC users, using state-of-the-art split-sample methods.¹³ While it has been shown to perform better than other published models and is the first model specific to CHC use, external validation has not yet occurred. Modelling also assumed that BMI remained constant throughout the lifetime and that laboratory testing costs were covered by health insurance in 50% of cases. Also, few clinicians participated in the second and third rounds of the Delphi study. Finally, it was beyond the model scope to capture certain risk factors for VTE including pregnancies, surgeries and more than two occurrences of VTE in one’s lifetime. Nevertheless, it would be interesting to assess the potential benefits that could appear if all women with high genetic risk of thrombosis would be identified early enough and preventatively treated during pregnancy and post partum.



Table 5 Scenario analyses from a health system perspective (with discounting)

Input parameter(s)	Base-case value	Scenario value	SoC		PP		Incremental costs (CHF)	Incremental QALYs	ICER CHF per QALY
			Average costs (CHF)	Average QALYs	Average costs (CHF)	Average QALYs			
Base case	All	NA	2033	23.901	2264	23.904	231	0.0030	76610
1. PP targets only 'high-risk' groups		Only PP for persons at high risk, while low-risk individuals go through SoC clinical pathway	2033	23.901	2276	23.902	243	0.0009	257926
2. Low-risk groups		a) Only PP for persons at low risk clinical risk factors), while high-risk individuals go through SoC clinical pathway b) Only PP for persons at low risk clinical risk factors), while high-risk individuals receive non-CHC	2033	23.901	2269	23.904	236	0.0021	113759
3. Age of first-time user	15–29	15–19	2239	24.557	2470	24.560	231	0.0029	78840
		20–24	2010	23.730	2240	23.733	230	0.0031	74170
		25–29	1573	22.806	1808	22.809	235	0.0023	101908
		30–34	1287	21.771	1525	21.773	238	0.0018	134312
		35–39	1201	20.625	1369	20.624	168	-0.0012	SoC dominant
		40–44	1174	19.371	1347	19.370	173	-0.0016	SoC dominant
		45–49	1040	18.013	1223	18.012	183	-0.0012	SoC dominant
		20–29 (uniform)	1792	23.267	2024	23.270	232	0.0026	88146
		20–29 (weighted)	1884	23.462	2115	23.465	231	0.0029	79164
4. Proportion of clinicians who review a woman's medical history during the recommendation of a CHC	84%	a. SoC and PP—100% medical history b. SoC 84% (same), PP 100% medical history	2021	23.901	2247	23.904	226	0.0031	73616
			2033	23.901	2247	23.904	214	0.0022	96178
5. Combined clinical risk factors	Delphi R3	a) assuming that 100% of clinicians would not recommend CHCs if more than one clinical risk factor is present	2034	23.902	2264	23.904	230	0.0026	87601
6. Discount rates	3%	5%	1751	16.698	1983	16.700	232	0.0019	120207
		2%	2253	29.834	2483	29.838	230	0.0039	59020
7. Time horizon	85 years	15 years	1707	10.591	1938	10.592	231	0.0009	270492
		30 years	1867	17.139	2097	17.141	230	0.0020	116633
		50 years	1939	21.903	2169	21.906	230	0.0028	82973

Continued

Table 5 Continued

Input parameter(s)	Base-case value	Scenario value	SoC		PP		Incremental costs (CHF)	Incremental QALYs	Incremental costs (CHF)	Incremental QALYs	ICER CHF per QALY
			Average costs (CHF)	Average QALYs	Average costs (CHF)	Average QALYs					
8. PP thresholds (5–40)	18	Threshold buffer ($\pm 10\%$)	2033	23.901	2264	23.904	231	0.0030	231	0.0030	77289
	5		2033	23.901	2362	23.911	329	0.0093	329	0.0093	35337
	10		2033	23.901	2295	23.908	262	0.0063	262	0.0063	41279
	11		2033	23.901	2288	23.907	255	0.0057	255	0.0057	44390
	12		2033	23.901	2282	23.907	249	0.0052	249	0.0052	47572
	13		2033	23.901	2277	23.906	244	0.0048	244	0.0048	50878
	14		2033	23.901	2274	23.906	241	0.0043	241	0.0043	55539
	15		2033	23.901	2270	23.905	237	0.0039	237	0.0039	60385
	16		2033	23.901	2268	23.905	235	0.0036	235	0.0036	66041
	17		2033	23.901	2266	23.905	233	0.0033	233	0.0033	70518
	19		2033	23.901	2263	23.904	230	0.0028	230	0.0028	83379
20		2033	23.901	2261	23.904	228	0.0025	228	0.0025	91892	
25		2033	23.901	2257	23.903	224	0.0016	224	0.0016	138605	
40		2033	23.901	2254	23.901	221	-0.0002	221	-0.0002	SoC dominant	
9. Changes to comparator strategy ('standard of care (SoC)')	Clinical pathway based on Delphi study	a. Do nothing (assign 100% CHC in SoC)	1982	23.894	2264	23.904	282	0.0105	282	0.0105	26925
		b. SoC and PP—prescribe all second generation CHCs (RR and cost second generation only for CHC prescriptions)	2022	23.905	2256	23.907	234	0.0021	234	0.0021	112446
		c. SoC only—no screening, prescribe progestogen only	1926	23.913	2264	23.904	338	-0.0088	338	-0.0088	SoC dominant
10. Market share	Lab testing	a	2037	23.900	2267	23.904	230	0.0033	230	0.0033	70101
		b	2023	23.896	2267	23.904	244	0.0078	244	0.0078	31138
11. PP instead of Factor II G20210A and Factor V Leiden tests	Lab testing	PP	2033	23.901	2034	23.902	1	0.0009	1	0.0009	751
12. CHC duration in ages 15–19	CHC duration based on distribution	35 years CHC duration (maximum)	4249	24.539	4456	24.546	207	0.0072	207	0.0072	28911

CHC, combined hormonal contraceptive; CHF, Swiss franc; ICER, incremental cost-effectiveness ratio; NA, not applicable; PP, Pill Protect; QALY, quality-adjusted life year; RR, relative risk.



Figure 3 Cost-effectiveness planes for the health system, health insurer and societal perspectives; CHF, Swiss francs; QALYs, quality-adjusted life years.

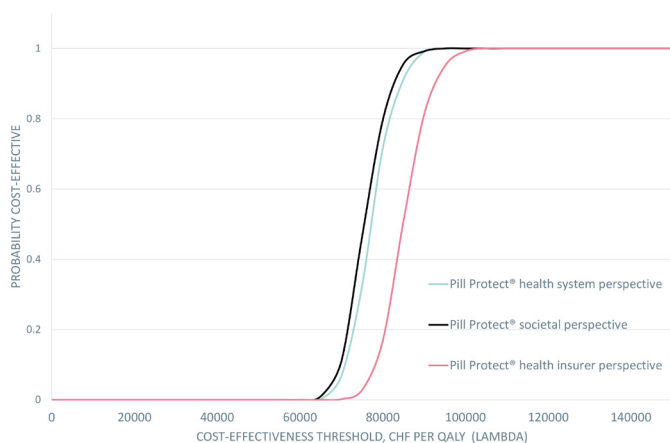

Figure 4 Cost-effectiveness acceptability curves; CHF, Swiss francs; QALYs, quality-adjusted life years.

Our literature review found that PP is currently the only algorithm available for screening for VTE risk related to CHCs, although other algorithms potentially marketable as products for future practice exist, such as ThromboInCode.⁴² Although this algorithm is not yet available in Switzerland and not specifically indicated for use in CHC prescribing, it potentially may be used in this way and considered a competitive alternative test. However, the PP test assesses more genetic variants linked to VTE risk in the context of CHC use than ThromboInCode. Nevertheless, future comparison of ThromboInCode with PP might be informative.

Overall, this study has indicated an opportunity for PP to provide accurate diagnosis and cost-effective benefits when used during the first recommendation of contraceptives for young women in Switzerland.

Author affiliations

¹Institute of Pharmaceutical Medicine (ECPM), University of Basel, Basel, Switzerland

²School of Public Health and Preventive Medicine, Monash University, Melbourne, Victoria, Australia

³Gene Predictis SA, Lausanne, Switzerland

⁴Women's Health Watch, Clarens-Montreux, Switzerland

⁵Department of Obstetrics and Gynecology, University Hospital Basel, Basel, Switzerland

⁶Laboratory of Haematology, La Timone Hospital, Marseille, France

⁷C2VN, Aix Marseille Université, INSERM, INRA, Marseille, France

⁸Pharmaceutical Care Research Group (PCRG), University of Basel, Basel, Switzerland

Acknowledgements The authors would like to thank Anis Fadhlouli and the remaining clinicians (anonymous) who participated in our modified Delphi study, and to those who willingly shared their knowledge (Robert Escher, Dimitrios Tsakiris) with the study team for the enhancement of our research project.

Contributors CSS led the Delphi study with practical assistance from ML and further design input from TP, JB, PS, ZA, JM, GT and MS. CSS undertook primary development of the ISM in MS Excel and NS programmed Stata model. ZA undertook model parameterisation. GT and MS designed the project. CSS, ZA, JM, GT and MS undertook the design of the base case and scenarios and parameters. GT and JM undertook literature review tasks. KH and VA provided pharmaceutical expertise. GT and MS obtained public funding for the project. All authors contributed to the drafting, revision, writing and of the manuscript.

Funding The research underlying this publication has been primarily funded by the Commission for Technology and Innovation (CTI; now Innosuisse), a Swiss public funding institution fostering academia-industry collaborations, under CTI Grant Number 18712.1 PFES-ES. According to CTI rules, an additional funding contribution of the involved company (Gene Predictis S.A.) was obligatory. Authors ZA, CSS, NS and MS have received the obligatory research funding by Gene Predictis S.A. via employment institution, and JM and GT are employed by Gene Predictis S.A.

Competing interests GT and JM are employed by and shareholders of Gene Predictis S.A., Thierry D. Pache is a Board Member and shareholder of Gene Predictis S.A. and Johannes Bitzer is a Scientific Board Member of Gene Predictis S.A.

Patient consent for publication Not required.

Provenance and peer review Not commissioned; externally peer reviewed.

Data availability statement Data are available upon reasonable request.

Open access This is an open access article distributed in accordance with the Creative Commons Attribution Non Commercial (CC BY-NC 4.0) license, which permits others to distribute, remix, adapt, build upon this work non-commercially, and license their derivative works on different terms, provided the original work is properly cited, appropriate credit is given, any changes made indicated, and the use is non-commercial. See: <http://creativecommons.org/licenses/by-nc/4.0/>.

ORCID iDs

Valerie Albert <http://orcid.org/0000-0001-5604-5468>

Kurt E. Hersberger <http://orcid.org/0000-0001-8678-697X>

REFERENCES

- Goldzieher JW, Rudel HW. How the oral contraceptives came to be developed. *JAMA* 1974;230:421–5.
- Jensen JT, Speroff L. Health benefits of oral contraceptives. *Obstet Gynecol Clin North Am* 2000;27:705–21.
- CADTH Optimal Use Reports. *Effectiveness of factor V Leiden and prothrombin mutation testing in patients presenting with a first unprovoked venous thromboembolic episode: a systematic review and economic analysis*. Ottawa (ON): Canadian Agency for Drugs and Technologies in Health, 2015.
- Rosendaal FR. Causes of venous thrombosis. *Thromb J* 2016;14:24.
- Heit JA, Phelps MA, Ward SA, et al. Familial segregation of venous thromboembolism. *J Thromb Haemost* 2004;2:731–6.
- Fruzzetti F, Trémollières F, Bitzer J. An overview of the development of combined oral contraceptives containing estradiol: focus on estradiol valerate/dienogest. *Gynecol Endocrinol* 2012;28:400–8.
- Plu-Bureau G, Maitrot-Mantelet L, Hugon-Rodin J, et al. Hormonal contraceptives and venous thromboembolism: an epidemiological update. *Best Pract Res Clin Endocrinol Metab* 2013;27:25–34.
- Germain M, Chasman DI, de Haan H, et al. Meta-Analysis of 65,734 individuals identifies TSPAN15 and SLC44A2 as two susceptibility loci for venous thromboembolism. *Am J Hum Genet* 2015;96:532–42.
- Kujovich JL. Factor V Leiden thrombophilia. *Genet Med* 2011;13:1–16.

- 10 Junker R, Koch HG, Auberger K, *et al.* Prothrombin G20210A gene mutation and further prothrombotic risk factors in childhood thrombophilia. *Arterioscler Thromb Vasc Biol* 1999;19:2568–72.
- 11 Hippisley-Cox J, Coupland C. Development and validation of risk prediction algorithm (QThrombosis) to estimate future risk of venous thromboembolism: prospective cohort study. *BMJ* 2011;343:d4656.
- 12 Merki-Feld G, Bitzer J, Seydoux J. Avis d'experts No. 35 Risque thromboembolique sous contraception hormonale, 2015. Available: <https://www.sggg.ch/fr/informations-dexperts/archives/> [Accessed 11 Oct 2018].
- 13 McDaid A, Logette E, Buchillier V, *et al.* Risk prediction of developing venous thrombosis in combined oral contraceptive users. *PLoS One* 2017;12:e0182041.
- 14 Ademi Z, Sutherland CS, Van Stiphout J, *et al.* A systematic review of cost-effectiveness analysis of screening interventions for assessing the risk of venous thromboembolism in women considering combined oral contraceptives. *J Thromb Thrombolysis* 2017;44:494–506.
- 15 Vernon E, Hiedemann B, Bowie BH. Economic evaluations of thrombophilia screening prior to prescribing combined oral contraceptives: a systematic and critical review. *Appl Health Econ Health Policy* 2017;15:583–95.
- 16 Husereau D, Marshall DA, Levy AR, *et al.* Health technology assessment and personalized medicine: are economic evaluation guidelines sufficient to support decision making? *Int J Technol Assess Health Care* 2014;30:179–87.
- 17 Ademi Z, Pfeil AM, Hancock E, *et al.* Cost-Effectiveness of sacubitril/valsartan in chronic heart-failure patients with reduced ejection fraction. *Swiss Med Wkly* 2017;147:w14533.
- 18 Parrott R, Hong SJ, Greenberg M. Family history unawareness of blood clot risk: links to misdiagnoses and illness uncertainties in personal and expert realms. *J Health Commun* 2015;20:35–42.
- 19 Firmann M, Mayor V, Vidal PM, *et al.* The CoLaus study: a population-based study to investigate the epidemiology and genetic determinants of cardiovascular risk factors and metabolic syndrome. *BMC Cardiovasc Disord* 2008;8:6.
- 20 Lidegaard Øjvind, Nielsen LH, Skovlund CW, *et al.* Risk of venous thromboembolism from use of oral contraceptives containing different progestogens and oestrogen doses: Danish cohort study, 2001–9. *BMJ* 2011;343:d6423.
- 21 Johansson M, Johansson L, Lind M. Incidence of venous thromboembolism in northern Sweden (veins): a population-based study. *Thromb J* 2014;12:6.
- 22 Martinez F, Ramirez I, Pérez-Campos E, *et al.* Venous and pulmonary thromboembolism and combined hormonal contraceptives. systematic review and meta-analysis. *Eur J Contracept Reprod Health Care* 2012;17:7–29.
- 23 Silverstein MD, Heit JA, Mohr DN, *et al.* Trends in the incidence of deep vein thrombosis and pulmonary embolism: a 25-year population-based study. *Arch Intern Med* 1998;158:585–93.
- 24 Sørensen HT, Horvath-Puho E, Pedersen L, *et al.* Venous thromboembolism and subsequent hospitalisation due to acute arterial cardiovascular events: a 20-year cohort study. *Lancet* 2007;370:1773–9.
- 25 Compagni A, Melegaro A, Tarricone R. Genetic screening for the predisposition to venous thromboembolism: a cost-utility analysis of clinical practice in the Italian health care system. *Value Health* 2013;16:909–21.
- 26 Laczkovics C, Grafenhofer H, Kaider A, *et al.* Risk of recurrence after a first venous thromboembolic event in young women. *Haematologica* 2007;92:1201–7.
- 27 Perneger TV, Combesure C, Courvoisier DS. General population reference values for the French version of the EuroQol EQ-5D health utility instrument. *Value Health* 2010;13:631–5.
- 28 Utne KK, Tavoly M, Wik HS, *et al.* Health-Related quality of life after deep vein thrombosis. *Springerplus* 2016;5:1278.
- 29 Sullivan PW, Slejko JF, Sculpher MJ, *et al.* Catalogue of EQ-5D scores for the United Kingdom. *Med Decis Making* 2011;31:800–4.
- 30 Bundesamt für Statistik. Konsumentenpreise, 2018. Available: <https://www.bfs.admin.ch/bfs/de/home/statistiken/preise/landesindex-konsumentenpreise.html> [Accessed 16 Oct 2018].
- 31 Bundesamt für Statistik. SwissDRG-Kodes (patientenbezogene Diagnosegruppen) gemäss Version 5.0, 2014. Available: <https://www.bfs.admin.ch/bfsstatic/dam/assets/2422598/master> [Accessed 11 Oct 2018].
- 32 FMH Swiss Medical Board. TARMED Tarifbrowser 1.08, valid from 1.1.2012, 2018. Available: https://www.fmh.ch/ambulante_tarife/tarmed-tarif/tarmed_tarifbrowser-datenbank.html [Accessed 11 Oct 2018].
- 33 SFOPH. Spezialtaetenliste, 2018. Available: <http://www.spezialtaetenliste.ch/> [Accessed 11 Oct 2018].
- 34 Apotheken. Apthekeon, 2018. Available: <https://www.toppharm.ch/> [Accessed 21 Jan 2019].
- 35 Bundesamt für Statistik. Ständige Wohnbevölkerung nACh Geschlecht und Altersklasse, am Ende des Jahres, 2017. Available: <https://www.bfs.admin.ch/bfsstatic/dam/assets/3202750/master> [Accessed 11 Oct 2018].
- 36 Bundesamt für Statistik. Erwerbstätigenquoten nACh Nationalität und Altersgruppe, 2017. Available: <https://www.bfs.admin.ch/bfs/de/home/statistiken/kataloge-datenbanken/tabellen.assetdetail.3783306.html> [Accessed 11 Oct 2018].
- 37 Bundesamt für Statistik. Monatlicher Bruttolohn (Zentralwert) nACh Berufsgruppen, Lebensalter und Geschlecht, 2014. Available: <https://www.bfs.admin.ch/bfsstatic/dam/assets/327991/master> [Accessed 11 Oct 2018].
- 38 Husereau D, Drummond M, Petrou S, *et al.* Consolidated Health Economic Evaluation Reporting Standards (CHEERS)--explanation and elaboration: a report of the ISPOR Health Economic Evaluation Publication Guidelines Good Reporting Practices Task Force. *Value Health* 2013;16:231–50.
- 39 Blondon M, Boehlen F, Fontana P, *et al.* Genetic testing to identify women at risk of venous thromboembolism with contraceptive pills: Evidence or hope-based tool? *Swiss Med Wkly* 2016;146:w14321.
- a5917563-6024-48e2-8050-6c90a9df3b6a. de Haan HG, Bezemer ID, Doggen CJM, *et al.* Multiple SNP testing improves risk prediction of first venous thrombosis. *Blood* 2012;120:656–63.
- 41 Morange P-E, Suchon P, Trégouët D-A. Genetics of venous thrombosis: update in 2015. *Thromb Haemost* 2015;114:910–9.
- 42 Rubio-Terrés C, Soria JM, Morange PE, *et al.* Economic analysis of thrombo inCode, a clinical-genetic function for assessing the risk of venous thromboembolism. *Appl Health Econ Health Policy* 2015;13:233–42.
- 43 Mantha S, Karp R, Raghavan V, *et al.* Assessing the risk of venous thromboembolic events in women taking progestin-only contraception: a meta-analysis. *BMJ* 2012;345:e4944.
- 44 Robertson S, Kremer P, Aisbett B, *et al.* Consensus on measurement properties and feasibility of performance tests for the exercise and sport sciences: a Delphi study. *Sports Med Open* 2017;3.
- 45 Bundesamt für Gesundheit BAG. Analysenliste, 2018. Available: <https://www.bag.admin.ch/bag/de/home/versicherungen/krankenversicherung/krankenversicherung-leistungen-tarife/Analysenliste.html> [Accessed 16 Oct 2018].
- 46 de Visser MC, Poort SR, Vos HL, *et al.* Factor X levels, polymorphisms in the promoter region of factor X, and the risk of venous thrombosis. *Thromb Haemost* 2001;85:1011–7.