

SCIENTIFIC REPORTS



OPEN

Cartography of rhodopsin-like G protein-coupled receptors across vertebrate genomes

Maiju Rinne¹, Zia-Ur-Rehman Tanoli^{1,2}, Asifullah Khan² & Henri Xhaard¹ 

We conduct a cartography of rhodopsin-like non-olfactory G protein-coupled receptors in the Ensembl database. The most recent genomic data (releases 90–92, 90 vertebrate genomes) are analyzed through the online interface and receptors mapped on phylogenetic guide trees that were constructed based on a set of ~14,000 amino acid sequences. This snapshot of genomic data suggest vertebrate genomes to harbour 142 clades of GPCRs without human orthologues. Among those, 69 have not to our knowledge been mentioned or studied previously in the literature, of which 28 are distant from existing receptors and likely new orphans. These newly identified receptors are candidates for more focused evolutionary studies such as chromosomal mapping as well for in-depth pharmacological characterization.

Interestingly, we also show that 37 of the 72 human orphan (or recently deorphanized) receptors included in this study cluster into nineteen closely related groups, which implies that there are less ligands to be identified than previously anticipated. Altogether, this work has significant implications when discussing nomenclature issues for GPCRs.

G protein-coupled receptors (GPCRs) are signalling proteins activated by for example neurotransmitters and neuromodulators and as such are involved in many physiological processes. Their location as a cellular gateway makes them key targets for drug discovery and chemical biology^{1–3}, and 30–50% of drugs on the market have been reported to target GPCRs directly or indirectly⁴.

GPCRs are well known for sharing a three-dimensional architecture characterized by seven transmembrane α -helical segments^{5,6} connected by loops. In the rhodopsin family, a well conserved disulphide bridge often connects the second extracellular loop and the third transmembrane segment. This architecture is reflected at the sequence level by conserved sets of amino acids that serve structurally or as determinants of signal transduction, e.g. to name a few the E/DRY, CWxP, NPxxY motifs in the transmembrane segments 3, 6 and 7 of the rhodopsin family^{7,8}. Additional family-specific motifs have been identified for examples in connecting loops⁹. Within each transmembrane segment, the most conserved amino acid will be referred to here as pivots (pivot amino acids are not always fully conserved: N1.50, 98% conservation; D2.50, 90%; R3.50, 95%; W4.50, 97%; P5.50, 78%; P6.50, 99%; P7.50, 88% see⁷). These amino acids are used as a basis of the widely used Ballesteros-Weinstein numbering¹⁰, where equivalent positions are reported by transmembrane segment number followed by relative distance to pivot, itself assigned the index 50.

The International Union of Basic and Clinical Pharmacology (IUPHAR) is responsible for the international classification of GPCRs and issues regular recommendations. GPCRs have been divided into five main families based on phylogenetic analyses^{11–13}. The largest, *Rhodopsin*, in human ~700 members, subdivides into four branches (α , β , γ and δ) and 13 sub-branches¹¹ and has originated through local duplications about 1400–1100 million years ago¹⁴. Families are further divided into subtypes¹⁵ that arouse, for many, 350–500 million years ago from two rounds of whole genome duplication (2R)^{16–22}. In ray-finned fish (not in lobe-finned or jawless fishes), a third specific genome duplication took place about ~250 million years ago, leading to fish-specific duplicates^{23–25}. In tunicates, GPCRs originated before the 2R and after the separation of invertebrates from chordates^{24–26}. In lamprey, it remains unclear whether the cyclostome-gnathostome split at the origin of jawed vertebrates happened before or after the second round of genome duplication^{27–29}.

¹Drug Research Program, Division of Pharmaceutical Chemistry and Technology, Faculty of Pharmacy, University of Helsinki, P.O. Box 56, FI-00014 University of Helsinki, Helsinki, Finland. ²Department of Computer and Information Sciences, Pakistan Institute of Engineering and Applied Sciences (PIEAS), P.O. 45650, Nilore, Islamabad, Pakistan. Correspondence and requests for materials should be addressed to H.X. (email: henri.xhaard@helsinki.fi)











Representative species	Lamprey	Fishes (<i>Actinopterygii</i>)		Fishes (<i>Sarcopterygii</i>)	Amphibian	Reptiles	Birds	Mammals		
	<i>Petromyzon marinus</i>	Cypriniformes (<i>Danio rerio</i>); Characiformes (<i>Astyanax mexicanus</i>)	<i>Lepisosteus oculatus</i> + <i>Takifugu rubripes</i> and 7 others	<i>Latimeria chalumnae</i>	<i>Xenopus tropicalis</i>	<i>Anolis carolinensis</i> ; <i>Pelodiscus sinensis</i>	<i>Gallus gallus</i> + 4 others	Monotreme	Marsupial	Placental
Whole genome duplication	1R/2R?	3R	3R, except <i>Lepisosteus oculatus</i> 2R	2R	2R	2R	2R	2R	2R	2R
Pictogram										
Number of genomes	1	2	9	1	1	2	5	1	3	65
Paralogous GPCR clades identified	22	118	134	95	69	74	52	16	19	11

Table 1. Species-specific counts of non-olfactory GPCRs clades without human orthologues in Ensembl.R91.

As consequence of the origin of vertebrate GPCRs through the 2R/3R, in an ideal scenario, for each ancestral receptor we expect four/eight paralogues (that can be referred to as “ohnologues”¹⁶, many ohnologues are simply equivalent to subtypes). Nonetheless, local duplications and deletions (pseudogenes)³⁰ may make the current day picture complex and, consequently, the expect four/eight ohnologues are most often not seen^{18,30}. Furthermore, ligand binding preferences do not necessarily indicates the closest possible evolutionary relationships; some receptors have acquired the same ligand specificity several times, for example α_1 -, α_2 -, and β - adrenoceptors that are parts of the amine family^{31,32}, or e.g. the cannabinoid receptors CB₁ and CB₂, and the recently deorphanized GPR₅₅ that are activated by the same endogenous ligand 2-Arachidonoylglycerol³³.

GPCRs have been identified and characterized in the 70’s and cloned in the 80’s, e.g. the well-studied rhodopsin³⁴ and β_2 -adrenergic receptor³⁵. The apparition of genomics in the 2000’s has brought an explosion in the amount of discovered GPCRs, yet GPCRs are in most cases named according to their human orthologues^{26,36–38}. This leads to complex nomenclature issues especially when new clades without human orthologues are identified^{39–41}. In addition, the repertoires in non-human vertebrate species are much less explored, and new subtypes or orphan receptors are often not annotated at all. The only way to date to tackle the issue of GPCRs in non-vertebrate species is the tedious manual annotation based on phylogenetic information.

Here, we conducted this manual annotation based on the online Ensembl database. The transcripts predicted in Ensembl are based on automated alignments matched to curated homologues sequences or ESTs. Ensembl gene trees are based on a consensus of five tree reconstruction methods: a maximum likelihood based on two types of distances and a neighbor-joining tree based on three types of distances. This annotation is a first step towards an experimental classification that would include cloning, pharmacological characterization, as well as a chromosomal analysis.

Results and Discussion

Overview. All data used for this study are available online and can be easily accessed using the codes provided (see the Experimental section).

This study was conducted based on the Ensembl genomic data^{42,43} twice with a five-year interval: 2012–2013, Ensembl release 67 (referred to as Ensembl.R67); and 2017–2018, Ensembl.R90–Ensembl.R.92. The text is organized according to the Ensembl.R91 trees (December 2017, available as an archive, see Experimental section). Some of the groupings may slightly differ in future releases. Ensembl.R92 (April.2018) became available during the final preparation of this manuscript and was used to solve a few ambiguities, as mentioned in text. The proposed new gene symbols were submitted to HUGO (Human Genome Nomenclature Committee) for initial consideration; for this purpose the suggested genes symbols were reevaluated against the Ensembl.R.94 (December 2018) and Ensembl.R.95 (February 2019) releases. They will be submitted to the other relevant committees on publication (MGNC, Mouse Genomic Nomenclature Committee; RGNC, Rat Genome and Nomenclature Committee, ZNC, Zebrafish Nomenclature Committee; XGC, Xenopus Gene Nomenclature Committee; CGNC, Chicken Gene Nomenclature Consortium). Therefore all gene symbols presented in this manuscript should be regarded as tentative until approved by the relevant committees.

Altogether, in Ensembl.R92 we identified 142 clusters of genes corresponding to non-olfactory rhodopsin-like GPCRs without human orthologues (Tables 1, 2), of which 69 have not been to our best knowledge previously described. Twenty-eight are distant from any group of receptors and likely orphan, and the others probable subtypes of existing receptors (Table 2). Not surprisingly, most of the new receptors are present in ray-finned fishes and only a few in placental mammals (Table 1). Nonetheless, most (23) of the new orphan receptors are found in two or more species clades (considering separately ray-finned and lobe-finned fishes, amphibians, birds, reptiles, monotreme, marsupial and placental mammalians). In addition, families that are evolutionary more recent and faster evolving such as purine (PUR) and chemokine (CHEM) contains a larger number of previously unidentified receptors (Table 2). We furthermore identify groups of ambiguous branching that need to wait for more and/or increased quality sequence data to be characterized (not annotated, see text below).

There are few aspects to keep in mind regarding manual annotations. First, we do not have enough manuscript space to detail the annotation of each of the 142 new receptor clades. Two examples are given as Supporting

	AMIN	MECA	PTGER	MLT	OPN	PEP	CHEM	SOG & MCH	LGR	MRG	PURIN	Others	Total
Subtypes	13	5	1	20	3	24	12	13	2	3	20	7	123
Orphans	2	1	1	0	0	1	5	2	0	0	10	2	24
Total orphan + subtypes	15	7	2	20	3	25	17	15	2	3	30	9	147
Including, novel	6	3	1	1	0	9	7	3	0	0	27	8	66

Table 2. Family-specific counts of non-olfactory GPCRs clades without human orthologues in Ensembl.R91.

information. The annotation process is in our opinion straightforward enough to be reproducible by the reader using the online data. Secondly, this is not a full characterization of the novel receptors, which would require pharmacological studies and chromosomal organization studies. Thirdly, sometimes the branching alone do not allow a distinction between subtypes or new orphan receptor clades. Fourthly, small discrepancies may exist between the guide trees and the text of this article, essentially because the guide trees are older (R.67). We encourage the readers to look at the most recent data and build an informed opinion.

Amine and trace amine receptors (AMIN). In the AMIN family (Fig. 1a,b) we suggest one new orphan receptor and four new subtypes that to our best knowledge have not been previously reported. This family was among the first discovered and its evolution has been comprehensively studied (see e.g.⁴⁴), in particular, for dopamine receptors^{40,45}.

Gene tree ADRA2A,2B, 2C; ADRB1,2,3; DRD1,5; DRD2,3,4; HTR2A,2B,2C; HTR6; HRH2. In the dopamine D_{2,3,4} receptor family, there are two new fish-specific clades found in coelacanth and ray-finned fishes: see ENSDARP00000127653, named here D_{2L} (gene: DRD2L)(not to be confused with the long splice variant of D₂); and see ENSAMXP00000016690, named D_{4L}. Previous work characterized the expression in zebrafish of a single D₃ and three D₂ receptors⁴⁶, whereas this study suggest seven zebrafish receptors in the D_{2,3,4} family: D_{2a}, D_{2b}, D_{2L}, D₃, D_{4a}, D_{4b}, and D_{4L}. A previously cloned and pharmacologically characterized α₂-adrenoceptor D subtype (ADRA2D) subtype was also found⁴⁷. Near the histamine receptor H₂ (HRH2), rooted by two lampreys, a gene cluster from gar/coelacanth/amphibian/sauropsids(7), see ENSMAP00000006842, was named GPR₁₈₇.

ADRA1A,1B,1C; HTR1A,1B,1C,1D,1E; HTR5,7. We identified at least two unannotated 5-hydroxytryptamine subtypes: 5-HT_{7B} (HTR7B) found in gar/fishes(10)/coelacanth, see ENSLACP00000008875, that has likely been cloned in zebrafish⁴⁸, and a set of genes in gar/coelacanth/sauropsids(7), see ENSLACP00000011078, that we name 5-HT_{7C} (HTR7C). A cluster of five genes from gar/coelacanth/birds(3), see ENSLOCP00000003684, may be orthologues of the mammalian 5-HT_{5B}. The 5-HT_{5B} is pseudogenic in humans, but well characterized in mice⁴⁹.

HRH1,3,4; CHRM1,2,3,4,5. In the histamine H_{1,3,4} subtree, a set of genes from gar/fishes(2)/amphibian/sauropsids(7)/mammals(4, 2 marsupials), see ENSLOCP00000006664, was named H₅ (HRH5). Near the muscarinic cholinergic receptors 4 and 2, a group of ray-finned fish genes (8), see ENSDARP00000128513, was named CHRM_{4B}; these muscarinic receptors have been cloned from zebrafish⁵⁰.

HTR4; TAAR. Equally distant from 5-HT₄ and trace amine (TAAR) receptors, a monophyletic group containing fishes(9)/coelacanth/gar/amphibian, see ENSLACP00000014144, was left unannotated. Near the 5-HT₄ subtree, a set containing gar/fishes(10)/coelacanth genes, see ENSLACP00000004821, was named 5-HT_{4B} (gene HTR4B; not orthologous to human 5-HT₄ since this later has spotted gar). The TAAR have been studied in mouse, rat, human and chimpanzee⁵¹ and fishes, where their repertoire is substantially larger than in human^{52,53}. A set of ray-finned fish genes, see ENSLOCP000000022119, may belong to a previously unannotated subtype.

Melanocortin/EDG/Cannabinoid/Adenosine (MECA) receptors. In the MECA family (Fig. 2a) we identified one new orphans, a new subtype, and a fish-specific receptor clade.

ADORA1,2,3. Two sets of genes are likely subtypes of a new orphan receptor, GPR₁₈₈, rooted by lamprey and ascidian sequences, see ENSCINP000000025465. The first set contains gar/coelacanth(duplicated)/fishes(9), see ENSLOCP000000022091; and the second includes fishes(2)/coelacanth/amphibian/reptiles(2), see ENSGMOP000000016757. The duplicated coelacanth sequences open the possibility of a third subtype, but not conclusively.

MC1,2,3,4,5R; GPR119. The orphan receptor GPR₁₁₉ has a potential subtype named GPR_{119B}, found in gar/sauropsids(5), see ENSLOCP00000002170.

S1PR1,2,3,4; LPAR1,2,3; GPR3,6,12; CNR1,2. A cluster of ray-finned fishes (9) genes suggest a new receptor close to GPR₃, see ENSAMXP00000025994. Nearby, another set has genes of gar/fishes(9)/coelacanth/amphibian/sauropsids(3)/marsupial(1)/monotreme(1), see ENSLOCP000000021577, and corresponds to GPR₁₈₅; this receptor has been cloned in *Xenopus laevis* (named also GPR_x⁵⁴). Two novel sphingosine-1-phosphate receptor subtypes have been previously reported in zebrafish⁵⁵, which should correspond here to a set of fishes(17)/coelacanth/reptile(1) and to S1PR_{3a} in fishes(10)/coelacanth.

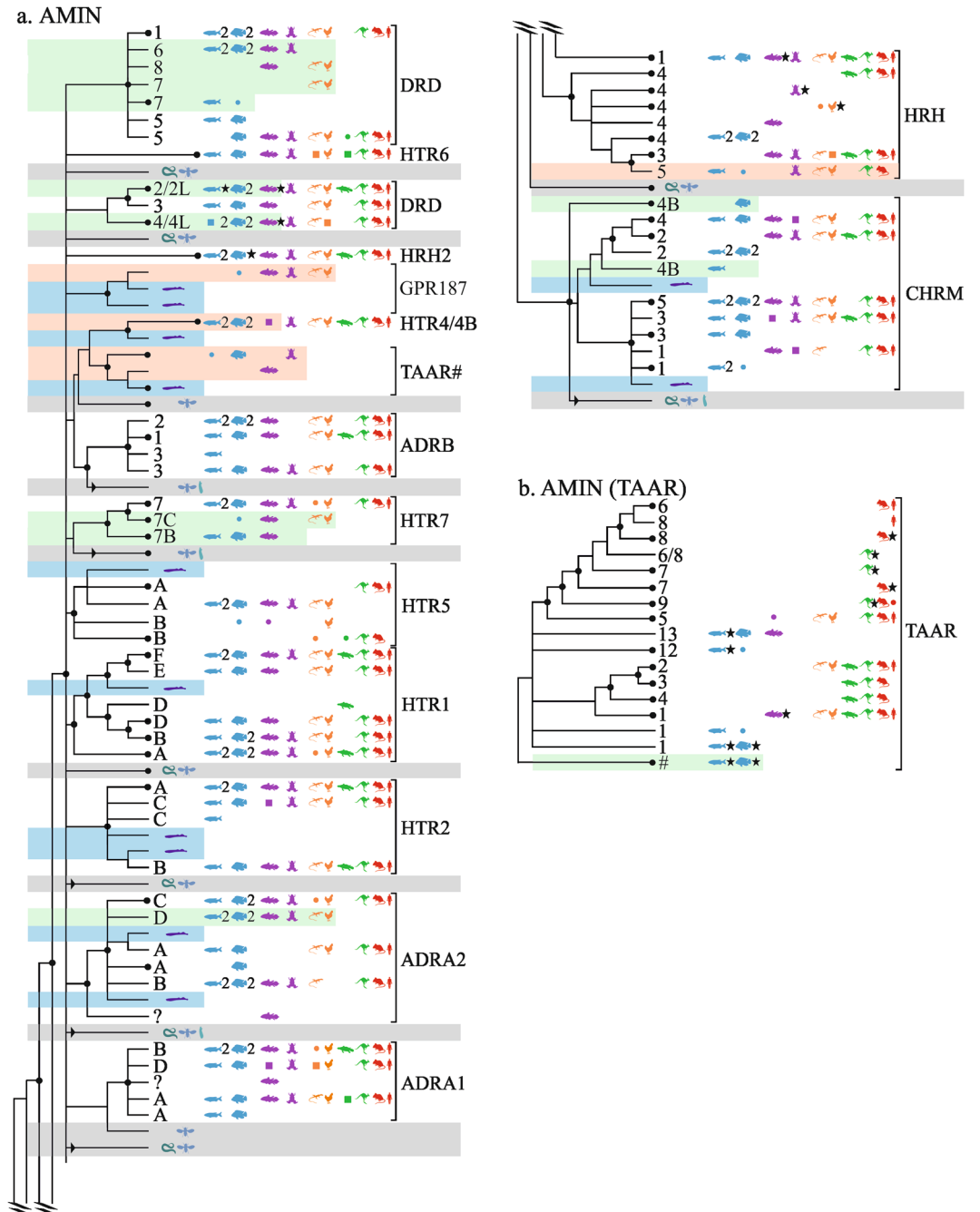

Figure 1. Overview of vertebrate GPCR clades mapped onto neighbor-joining trees of the α -branch (1/2). AMIN (a,b). Some branches are collapsed together. Species symbol, see Table 1. Squares, genes mistakenly removed during the curation process; circles, sequences of a representative species added in Ensembl.R90-R91 releases. Internal duplications (stars), presence of 3R duplicates (number “2”). Isolated non-assigned sequences (“?”) or genes in Ensembl.R67 that are not found in further releases (“ Δ ”). Bootstrap values above 65% (black circles). Highlights: new receptors that have (green) or have not (light red) been to our knowledge previously reported; presence of putative ancestral sequences from lamprey (light blue) or early vertebrates or invertebrates (light grey). Some branches have been collated together.

Opsin (OPN) receptors. In the OPN family (Fig. 2b), one new fish-specific opsin was identified. OPN has been extensively studied, in particular cone visual pigments⁵⁶, UV-sensitive photoreceptors⁵⁷, and melanopsins⁵⁸. Zebrafish has 10 classical visual photo pigments and 32 non-visual opsins^{57,59}.

OPN1MW/LW/SW; OPN3/4/5; RHO; RRH. Near OPN_{8a} , receptors from a set found in gar/fishes(7), see ENSLOCP00000020544, were named OPN_{8b} . They come in addition to the OPN_{4-9} in zebrafish⁵⁹.

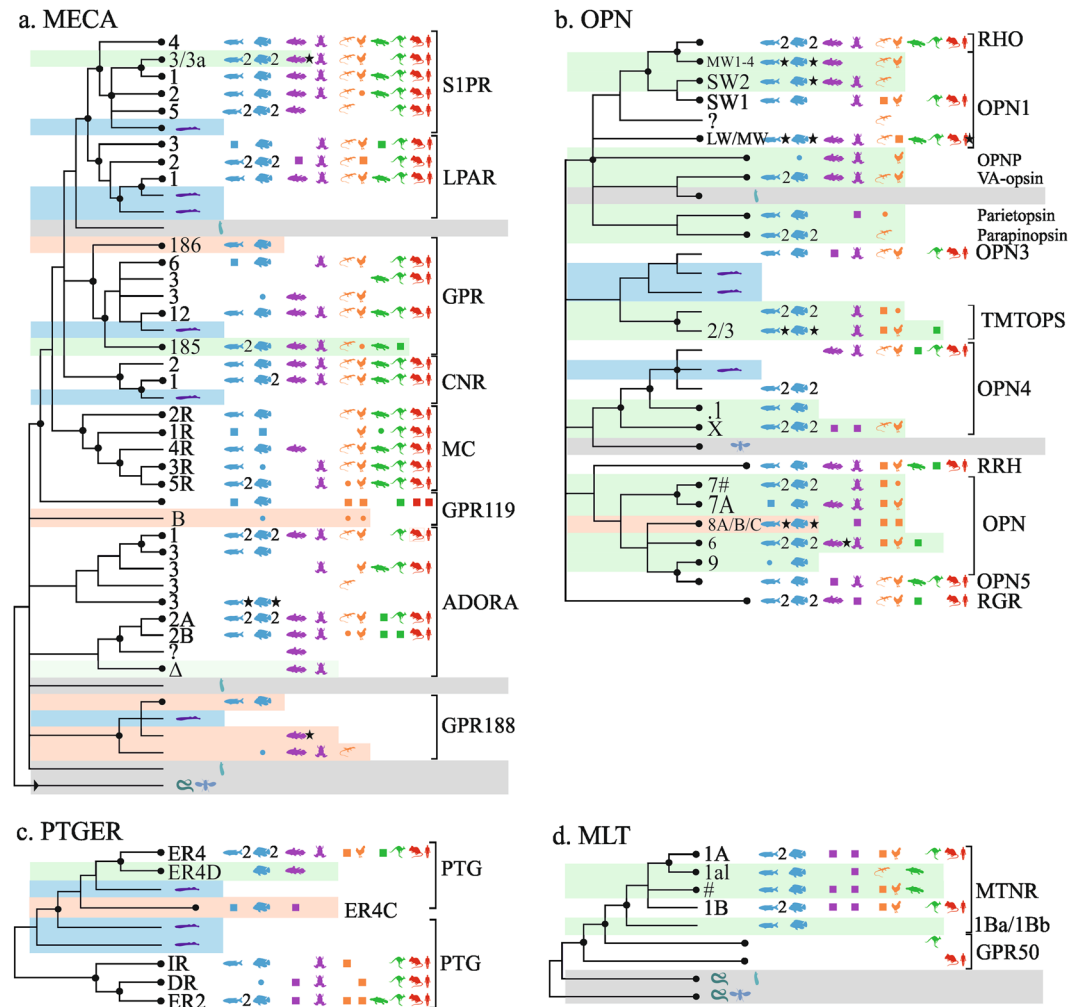

Figure 2. Overview of vertebrate GPCR clades mapped onto neighbor-joining trees of the α -branch (2/2). MECA (a); OPN (b); PTGER (c); MLT (d). Caption otherwise similar to Fig. 1.

Prostaglandin (PTGER) receptors. In the PTGER family, one new subtype was identified (Fig. 2c).

PTGER_{1,2,3,4}; PTGDR; PTGIR; PTGFR; TBXA_{2R}. Near *PTGER₄*, a group of fishes(7)/coelacanth/spotted gar, see ENSLACP00000020254, is a probable new subtype, *PTGER_{4D}* that has been previously characterized in zebrafish⁶⁰. In addition, a group of gar/fishes(11)/coelacanth genes, rooted by lamprey, see ENSAMXP00000018684, suggests a new subtype *PTGER_{4C}*.

Melatonin (MLT) receptors. In the melatonin tree, no new receptors could be identified (Fig. 2d).

MLT; GPR50. Ambiguities in this tree were lifted in Ensembl.R92. A complete set containing gar/fishes(10)/coelacanth/amphibian(duplicated)/sauropsids(7)/platypus, see ENSLOCP00000018152, clusters with *GPR₅₀* (data from R.95). Another set includes lamprey/gar/fishes(9)/amphibian/sauropsids(2)/platypus, see ENSLOCP00000014362, was named *MTNR_{1a1}*. A third set of fishes (4), see ENSDARP00000070419, was named *MTNR_{1Ba/1Bb}*. Three MLT subtypes have been previously cloned in zebrafish⁶¹.

Peptide (PEP) receptors. In the PEP family (Fig. 3a–c), we identified ten vertebrate receptors without human orthologues, one of which is likely a new orphan. PEP is generally conserved, retaining many lamprey sequences at the root of receptor clades.

NTSR; GPR39; MLNR; GHRS; NMUR; TRHR. Near *GPR₃₉* and neurotensin receptors (gene: *NTSR*), rooted by lamprey, a set of gar/fishes(3)/coelacanth/amphibian genes, see ENSXETP00000007421, suggest a new orphan, *GPR₁₈₉*.

The motilin receptor (gene: *MLNR*) has one novel subtype, *MLNR_B* that contains coelacanth/amphibian/reptiles(2), see ENSLACP00000009190. A closely branched set of gar/fishes(9) genes, see ENSLOCP00000011352, may additionally belong to *MLNR_B*.

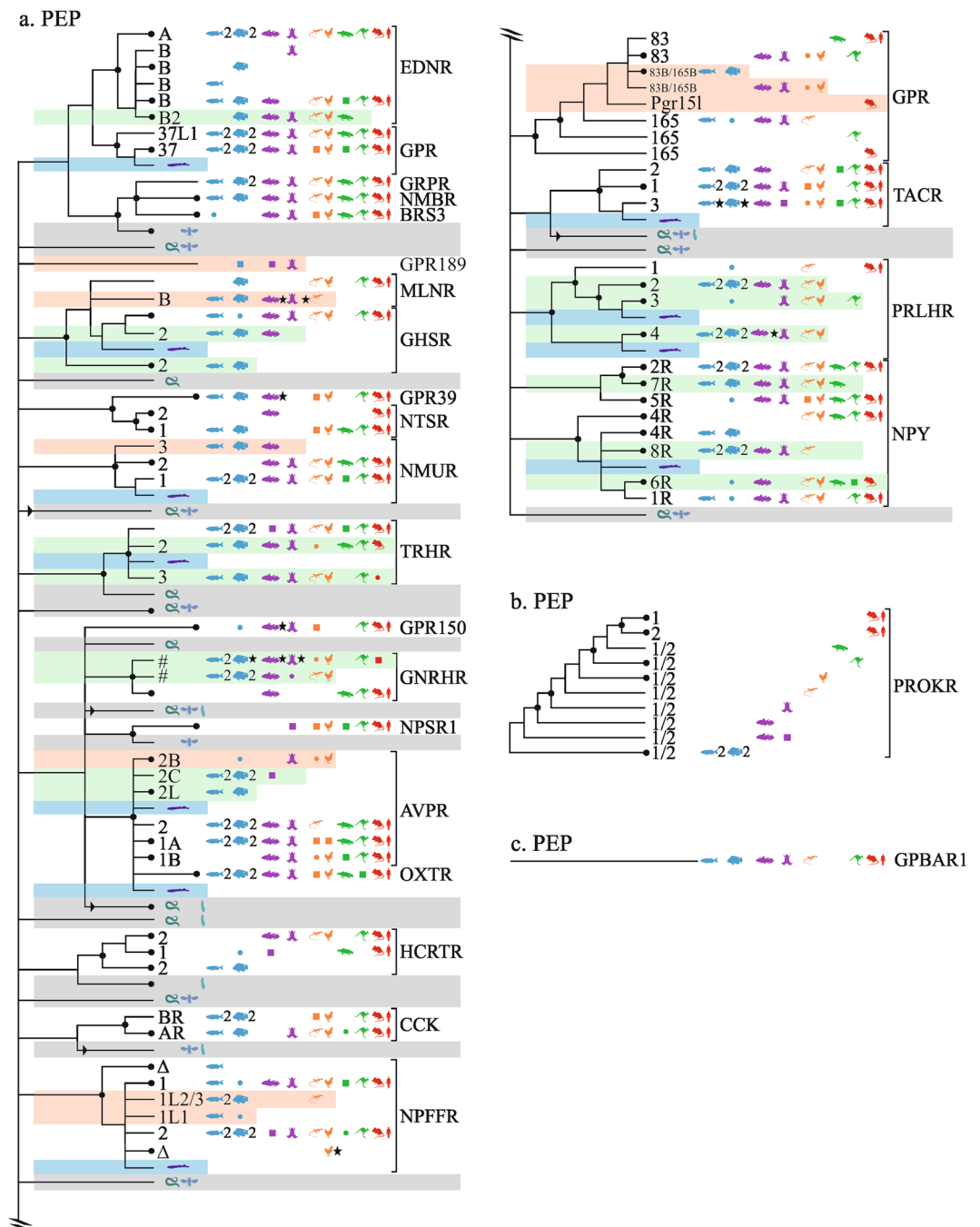

Figure 3. Overview of vertebrate GPCR clades mapped onto neighbor-joining trees of the β -branch. PEP receptors. Caption otherwise similar to Fig. 1.

The growth hormone secretagogue receptor (GHSR) tree includes three groups of fishes: one containing gar/zebrafish, see ENSLOCP00000009072, likely orthologous to human GHSR; one containing gar/fishes(10)/coelacanth, see ENSLOCP00000000036, that was named GHSR₂; and a set of fishes (11, duplicates in cave fish), see ENSAMXP00000003803, also orthologous to human GHSR. Four goldfish receptors (GHS-R1a type 1/type 2, GHS-R2a type 1/type 2) have been previously suggested^{62,63}.

The thyrotropin-releasing hormone receptors 1–3 (TRHR) are resolved in Ensembl.R92 as one orthologue and two paralogues of the human TRHR receptor. Four receptors (THR_{1a}, THR_{1b}, THR₂, THR₃) have been previously characterized in medaka fish⁶⁴ and three cloned in frog⁶⁵.

The neuromedin U receptors (NMUR) are divided into NMUR₁ and NMUR₂, both with lamprey orthologues (ENSPMAP00000009319, ENSPMAG00000001504). Two sets of fish genes were assigned to NMUR₁ (based on Ensembl.R92). A set of sequences found in lamprey (ENSPMAP00000007962) and gar/fishes(10)/coelacanth, see ENSLOCP00000004052, was named NMUR₃.

NPF; *QFRPR*; *HCTR*; *NPY4,8,6,1*; *NPY5*; *NPY7*; *NPY2R*; *PRLHR*. Two groups of genes are likely orthologues of *NPF*_{R1}: a gar/fishes(11) set, see ENSLOCP00000019807, named here *NPF*_{R1,2/3}; and gar/fishes(3), see ENSLOCP00000018374, named *NPF*_{R1,1}. Two reptile genes branch with either of these receptors.

Two groups of two novel prolactin releasing hormone receptors (*PRLHR*) are found: the first group is rooted by lamprey (ENSPMAP00000011235) and comprised of one set comprising gar/fishes(16, duplicated)/coelacanth/amphibian/birds(3), see ENSLOCP00000018414, named here *PRLHR*₂; and another set with gar/amphibian/sauropsids(7)/marsupials(2), see ENSLOCP00000022432, named *PRLHR*₃. The other group is also rooted by lamprey (ENSPMAP00000008908) and comprises a gar/fishes(7)/coelacanth/amphibian/sauropsids(6) set, named *PRLHR*₄; and another gar/fishes(9)/coelacanth set, see ENSLACP00000014694 (removed from Ensembl subsequent releases). Three homologues of the mammalian receptors have been cloned in chicken⁶⁶, presumably *PRLHR*₂₋₄.

In the neuropeptide Y receptor family, three unannotated receptors *NPY*₆, *NPY*₇, and *NPY*₈ have been described previously⁶⁷⁻⁷⁰.

AVPR; *OXTR*; *NPSR*; *GNHR*. Three clusters of vasopressin (*AVPR*) receptor genes are found: one with gar/amphibian/sauropsids(6), see ENSLOCP0000001209, named *AVPR*_{2B}; one comprised of fishes(4) genes, see ENSDARPO0000119491, named *AVPR*_{2j}; and one with gar/fishes(14)/coelacanth, see ENSLOCP00000013628, named *AVPR*_{2C}. Presumably *AVPR*_{2j} and *AVPR*_{2C} have been previously reported and named respectively V2-like and V2B⁷¹.

We found several interesting gonadotropin-releasing hormone receptors (*GNRHR*) groups, most including lamprey sequences at their root, whose annotation will require further study since Ensembl.R92 has clarified some of the branchings, but not all. The first contains gar/fishes(27)/coelacanth/amphibian, see ENSLOCP00000017682. The second includes fishes(16)/coelacanth/amphibian/sauropsids(6), see ENSLOCP00000010658. The remaining groups are coelacanth/amphibian/reptile(1), reptiles(5), and placental(31)/marsupial(3) mammals (see ENSMEUP00000014678). The evolution of *GNRH* receptors has been previously studied⁷² and four zebrafish *GNRHR* previously cloned⁷³.

GRPR; *BRS3*; *NMBR*; *EDNRA,B*; *GPR37,37L*. A group constituted of gar/fishes(8)/coelacanth/amphibian/sauropsids(7)/platypus, see ENSLOCP00000018439, likely corresponds to a previously reported endothelin receptor, *EDNR*_{B2}⁷⁴.

TACR1,2,3; *PROKR1,2*; *GPR83*; *GPR165*. Ensembl.R92 resolves *Pgr*₁₅₁ as a new orphan present in many species: gar/fishes(8)/coelacanth/amphibian/sauropsids(6)/mammals(14 genes from rodents/rabbit), see ENSLACP00000018091. Ensembl.R95 reveals a new subtype of *GPR*₈₃, annotated *GPR*_{83L}, and *Pgr*₁₅₁ to be a mammalian duplicate of *GPR*₁₆₅.

Chemokine (CHEM) receptors. In CHEM, we report eight novel receptors, of which four are likely orphans, one divided into two subtypes (Fig. 4a). The assignment of receptors in CHEM is difficult due to a fast evolution rate and numerous internal duplications, and additional subtypes will certainly be defined when more data becomes available. Evolution of the chemokine system has been comprehensively studied⁷⁵.

LTB4R, *FPRI,2,3*, *GPR32*, *GPR33*, *CMKLR1*, *C5ARI*, *C3ARI*, *PTGDR2*, *GPR1*, *GPR152*. Near the leukotriene-4 receptors (*LTB*₄R_s) we suggest a new orphan receptor *GPR*₁₉₀, composed of two (or three) subtypes. A set of gar(duplicated)/fishes(16)/coelacanth(duplicated)/sauropsids(7) genes, see ENSLOCP00000021707, was named *GPR*_{190A}. The second subtype is composed of gar(duplicated)/fishes(32,internal duplications)/marsupials(2), see ENSLOCP00000021705, and named *GPR*_{190B}. A lonely platypus sequence (ENSOANP00000021820), complete with respect to its GPCR signature, may represent a third subtype. Two sets of genes near *LTB*₄R_{1/2} (in Ensembl.R92) may be orthologues of existing human receptors (sets removed in E.95). Three *LTB*₄R have been identified in zebrafish⁷⁶.

The branching near the formyl peptide receptors *FRP*_{1,2,3} and *GPR*₃₂ is especially blurred, and Ensembl.R92 helps understand the recent history. *FRP*_{1,2,3} have arose through local duplications, and marsupial(3) sequences, see ENSSHAP00000001972, are likely orthologous to the *FRP*_{1,2,3} set. *GPR*₃₂ is likely rooted by seven monotreme and marsupial genes, see ENSOANP00000022386; and the *FRP*_{1,2,3}-*GPR*₃₂ group is likely rooted by a sequence from turtle, see ENSPSIP00000009727.

Near *GPR*₁ (in Ensembl.R92), a complex cluster contains four sets of coelacanth genes (some duplicated) branching with two sets of fishes and one set (9 duplicates) of amphibian genes, see ENSLACG00000005198. This group was named *GPR*_{1B}.

Near *GPR*₃₃ and the chemerin chemokine-like receptor 1 (*CMKLR*₁), taking shape in Ensembl.R92, there is a set comprised of fishes(2)/amphibian/reptile(lizard) genes, see ENSXETP00000062533, that was named *GPR*₁₉₁. Nearby is another orphan, with several subtypes, named *GPR*₁₉₃ and composed of: coelacanth/reptile(lizard), see eg ENSLACP00000014297; gar/fishes(20, internally duplicated), see ENSLOCP00000021780; isolated genes from lizard (ENSACAP00000004236) and coelacanth (ENSLACP00000021116). There is also a large set of gar/fishes (31 genes, see si:dkey-117a8.4) of ambiguous positioning. Nearby, a set of gar/fishes(26, internal duplications) genes, see ENSLOCP00000022270, was named *GPR*₁₉₂; *GPR*₁₉₂ may be divided into subtypes since it is branched to coelacanth/sauropsid (5) and amphibian/reptiles(5) sets, indicating an internal duplication in tetrapods.

CCR1,2,3,4,5,6,7,8,9,10; *ACKR2,4*; *CXCR1,2,3,4,5,6*; *CX3CR1*; *XCR1*. Three sets of fish genes were difficult to assign. Two of these sets are resolved in Ensembl.R92 and tentatively assigned to the fishes orthologues to *CCR*₈, see ENSLOCP00000022371, as well as to a fish-specific clade containing gar/fishes(8), see

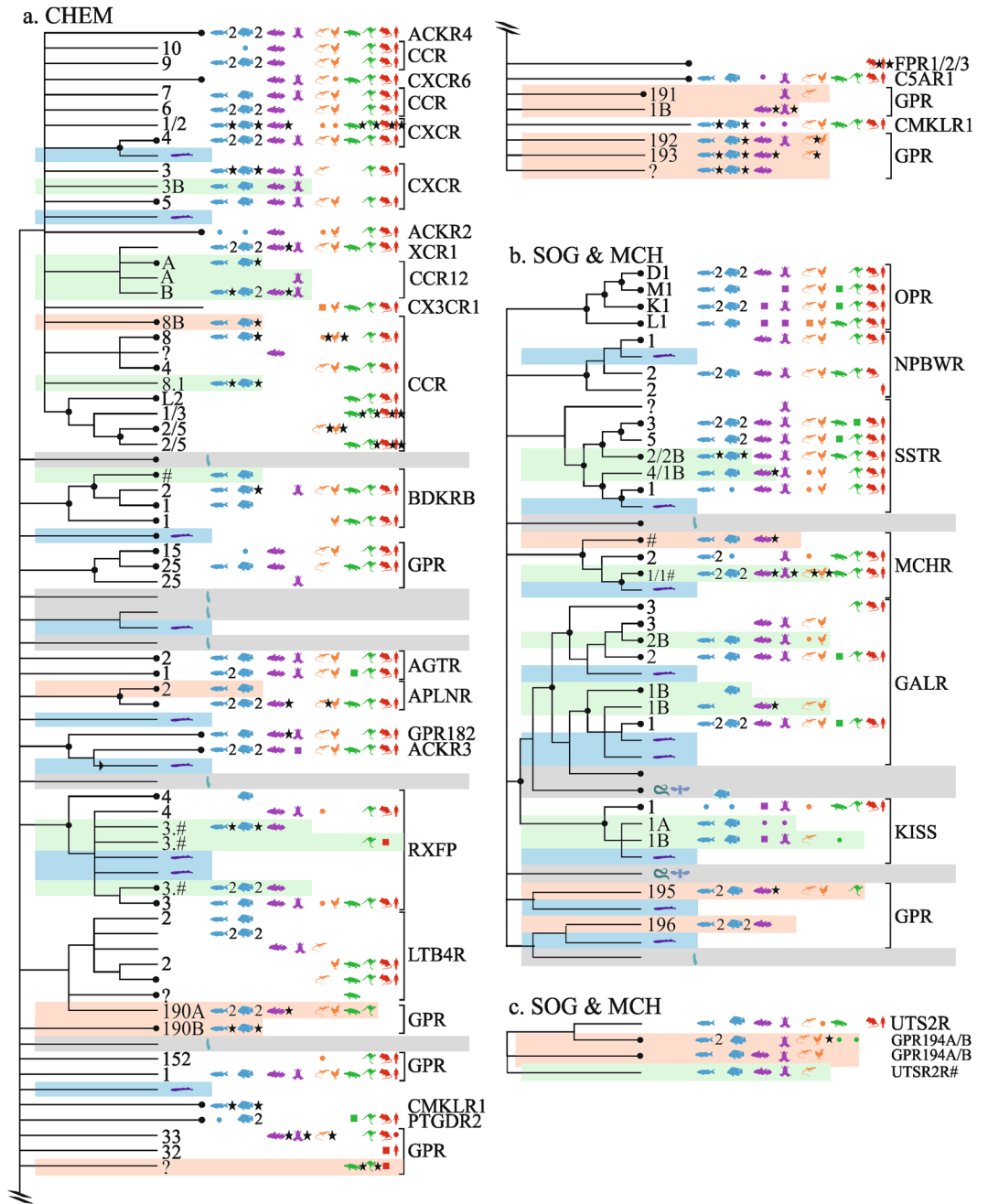

Figure 4. Overview of vertebrate GPCR clades mapped onto neighbor-joining trees of the γ -branch. (a) CHEM (b,c) SOG and MCH receptors. Caption otherwise similar to Fig. 1.

ENSLOCP0000000990, named CCR_{8B}. A third group comprising gar(duplicated)/fishes(14)/coelacanth, see ENSLOCP00000022422, is located at the root of the mammalian CCR_{1,2,3,4,5} and CX3CR₁ and probably correspond to orthologues of CCR₂ and CCR₅. We also identified already reported fish-specific receptors, CXCR_{3B} characterized in common carp⁷⁷ (ENSLOCP00000016977) and CCR_{12A,B} identified in orange-spotted grouper (see ENSLOCP00000022265)⁷⁸.

AGTR1,2; *BDKRB1,2*; *GPR15,25,182*; *APLNR*; *ACKR3*; *RXFP3,4*. The bradykinin receptor B2 (*BDKRB₂*) has an additional set gar/fishes(6) genes, probable result of a local duplication, see ENSLOCP00000021801. A set of gar/fishes(20)/coelacanth (also a fragmental wallaby sequence), see ENSLOCP00000020198, may be paralogous to the apelin receptor (*APLNR*). A second group of fishes(11) nearby, see ENSAMXP00000021714, was assigned as *APLNR₂*.

Human relaxin/insulin-like family peptide receptor 3 (*RXFP₃*) has orthologues in fish (ENSLOCP00000021654); a paralogous group comprising gar/fishes(18)/coelacanth, see ENSLOCP00000009554. Near *RXFP₄* (that has fish orthologues too) there is evidence of a new subtype comprised of gar/fishes(22, duplicated)/coelacanth/

mammal(2, including one marsupial) sequences, see ENSLOCP00000022049), as well as a fish-specific set of duplicates (9, annotated rxfp3.2b). These new receptors have been named here RXFP_{3,#} pending further studies and probably have been previously described as RXFP₃₋₂ and RXFP₃₋₃^{79,80}.

Somatostatin-opioid-galanin (SOG) and melanin-concentrating hormone (MCH) receptors.

In the SOG and MCH families we suggest five previously unreported receptor types (Fig. 4b,c), including three orphans. For a review of neuropeptide signaling systems see⁸¹.

OPRD1, *MI*, *KI*, *L1*; *NPBWR1,2*; *SSTR1,2,3,4,5*; *MCHR1,2*. In the somatostatin (SSTR) receptor group, near SSTR₂ a gar/fishes(5) group named SSTR_{2B}, probable result of an internal duplication, see ENSLOCP00000021860, has been described previously as SSTR₆⁸². Nearby, a group of fishes and coelacanth represent a new SSTR subtype, SSTR_{1B}, since SSTR₄ has lost its fishes with the exception of coelacanth^{82,83}.

Branching close to MCHR₂, there is a gar/fish(10)/coelacanth(duplicated) set, see ENSLACP00000004413. Near MCHR₁, two new subtypes are suggested: a coelacanth/amphibian/reptile(1) set, see ENSLACP00000017963; and a larger set comprising gar/fishes(14,duplicated)/coelacanth/sauropsids(5), see ENSLACP00000009737. Mammals have five melanocortin receptors and one or two MCH receptors, zebrafish six melanocortin (extra MC5RB) and three MCH receptors; fugu four MCR (MC3R missing) and two MCHR; Two MCHR receptors have been cloned in goldfish and four MCHR receptors have been cloned in *Xenopus tropicalis*⁸⁴. No annotations are proposed due to the complexity of the Ensembl trees for this subfamily.

CCKAR; *CCKBR*; *GPR19*; *KISS1R*; *GALR1,2,3*. Near the Kisspeptin receptor 1 (KISS₁), three unassigned sets of genes were detected. The first contains gar/amphibian, see ENSLOCP00000002856, and was named KISS_{1R_A}. The second set contains gar/fishes(10)/coelacanth/amphibian, see ENSLOCP00000003036, and was named KISS_{1R_B}; this receptor has likely been studied in ray-finned fishes⁸⁵. A related set contains gar/coelacanth/reptiles(2), see ENSLOCP00000008391, and the tree furthermore includes fragmental sequences at the root of KISS₁ (not discussed here).

In Ensembl.R92, the human galanin receptor 1 (GALR₁) has two sets of paralogous fish genes (human GALR₁ having its own fishes), rooted by a lamprey sequence (ENSPMAP00000000353). A set of gar/fishes(7)/coelacanth(2)/sauropsids(7) genes, see ENSLACP00000010695, was named GALR_{1B}. Near GALR₃, a paralogous branch with gar/fishes(10)/coelacanth/amphibian/sauropsids(4), see ENSLOCP00000001326, was named GALR_{2B}. Avians have been reported to have two new types in addition to Galr₁ and Galr₂: GalR₁, GalR₁-like, GalR₂-like; four galanin receptors have been isolated from European sea bass (named GalR_{1a}, 1b, 2a, 2b)^{86,87}.

Two new orphans were identified near the cholecystokinin (CCK) A and B receptors (grouped with PEP in Ensembl.R92). One is composed of fishes(8)/coelacanth(2)/sauropsids(6), see ENSLOCP000000021858, and was named GPR₁₉₅; this receptor may have two subtypes because of coelacanth duplicates. The other is fish-specific and in Ensembl.R92 occupies its own tree, see ENSLOCP00000007402. It contains lamprey, 3R-duplicated ray-finned fishes(16), and coelacanth, and was named as GPR₁₉₆.

UTS2R. Previously four urotensin 2 receptor (UTS_{2R}) subtypes have been named as UTS_{2R₂₋₅}⁸². A set of gar/fishes(6)/coelacanth/amphibian/sauropsids(6), see ENSLACP00000012826, is orthologous to human UTS_{2R}; A set from gar/fishes(9)/coelacanth/amphibian, see ENSLACP00000003013 is a probable new UTS_{2R} subtype. The Ensembl.R95 gene tree suggest two subtypes of a new orphan receptor, GPR₁₉₄: gar/fishes(2)/sauropsids/marsupials(2)/monotreme, see ENSLOCP00000022204, named GPR_{194A}; and gar/fishes(10)/amphibian/birds(3), see ENSLOCP000000021948, named GPR_{194B}.

Leucine-rich repeat (LGR) and Mas-related (MRG) receptors. In the MRG and LGR families, no new vertebrate receptors were found (Fig. 5a,b).

LGR4,5,6; *LHCGR*; *FSHR*; *TSHR*; *RXFP1,2*. The LGRs are rooted by a set of fish genes (6, see ENSTRUP00000003361) likely orthologous to human LGR₅. A set of gar/fishes(2)/coelacanth/amphibian/sauropsids(5)/marsupials(2) genes, see ENSLOCP00000018098, corresponds to the previously described RXFP_{1B}⁷⁹, annotated here RXFP_{2L} (marsupial and bird genes not found in R.95). A fish-specific luteinizing hormone receptor (LH), see ENSLOCP00000020088, has also been reported⁸⁸.

MRGPRD; *MRGPRF*; *MRGPRG*; *MRGPRE*; *MRGPRX1,2,3,4*; *MRGPRa,b*; *MAS1*; *1L*. The evolution of the MAS1, MAS1 oncogene-like, and MAS-related GPR (MRG) families is complexified by numerous internal duplications. A large group of sauropsid sequences, locally duplicated, could be orthologous to the mammalian MRGPR, see ENSGALP000000047269, named here MRGPR₁; A group of placental and marsupial mammals, see ENSSHAP00000018195, named MRGPRH. Nearby is a cluster of reptile genes, see ENSACAP00000019338, which may be orthologous or may represent a new subtype. MAS receptors have been reported to arise in amphibians⁸⁹, and the MAS family tree is rooted by a group of amphibians, MAS_{1L}, see ENSXETP000000063951. Three clusters of fish genes were positioned in Ensembl.R91 with MAS/MRGPRD but in the newer Ensembl.R92 are aggregated with GPR_{1B} (see ENSLACP00000001563, described above in the CHEM/CMKRL1 tree).

Purine (PUR) receptors. The PUR family is the most uncharted and we identified 27 new receptors, including 12 orphans (Fig. 5c).

LPAR4,5,6; *PTAFR*; *F2LR1/2/3*; *P2RY8*; *P2YR10*; *F2R*; *GPR4,18,35,55,65,68,132,174*. Near LPAR₅, a set of gar(duplicated)/fishes(2)/coelacanth(3, internally duplicated) was assigned to a new orphan probably with two

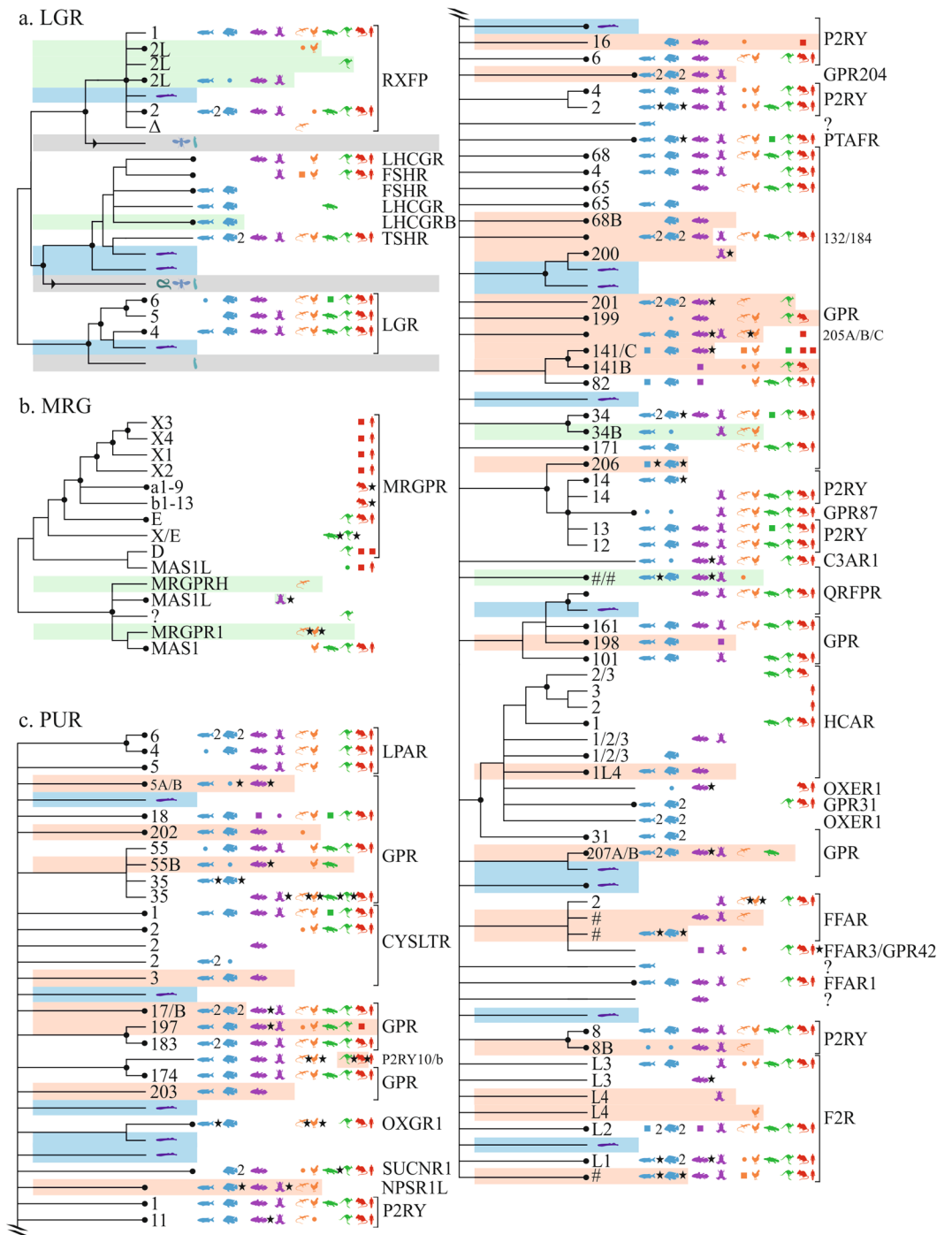

Figure 5. Overview of vertebrate GPCR clades mapped onto neighbor-joining trees of the δ -branch. (a) LGR (b) MGR (c) PUR. Caption similar to that of Fig. 1.

subtypes, see ENSLOCP00000021495, named $LPAR_{5A/B}$. Near PTAFR, a set of genes comprising gar/coelacanth(duplicated)/sauropsids(2)/mammalian (2, one marsupial), see ENSLOCP0000002041, was named GPR_{199} .

Near $LPAR_{4/6}$, a set with gar/fishes(4)/coelacanth/reptile(1), see ENSLOCP00000021661, was named GPR_{202} . Another orphan is composed of two amphibian and two lamprey sequences, see ENSXETP00000036876, named GPR_{200} . Near GPR_{55} , a full set of genes from gar/fishes(2)/coelacanth(duplicated)/sauropsids(5)/monotreme(1), see ENSLOCP00000021497, was named GPR_{55B} .

The receptors GPR_4 , GPR_{68} , GPR_{65} and GPR_{132} branch together with a new orphan, named GPR_{201} , divided into two subtypes. One of these subtypes contains gar(7 duplicates)/fishes(2)/reptile(1)/marsupials(2), see ENSLACP00000013584; the other contains gar/fishes(10)/coelacanth, see ENSLACP00000020885.

Near GPR_{65} (GPR_{68} in E.95) there is a set of fishes(5)/coelacanth, see ENSLACP00000000626, was named GPR_{68B} . Near GPR_{132} a set of gar/fishes(10)/coelacanth genes, see ENSLACP00000009633, was assigned to

GPR₁₈₄. Near P₂RY₁₀ and GPR₁₇₄, a group of gar/fishes(3)/coelacanth genes, see ENSLACP00000004667, was named GPR₂₀₃.

The coagulation factor II receptor F₂RL₃ is prone to local duplications, for example in spotted gar (see ENSLOCP00000014196) or coelacanth (see ENSLACP00000003039). Near F₂RL₃, a group of amphibian/birds(5), see ENSXETP00000005770, was named F₂RL₄. A set of fishes(18) paralogous to human F₂R, see ENSAMXP00000020201, need further consideration for annotation.

Near P₂RY₈, a group constituted of gar/fish/coelacanth/amphibian/reptiles(2), see ENSLOCP00000021876, was named P₂RY_{8B}. Nearby a coelacanth duplicate (ENSLACP00000004454) could not be assigned. In P₂RY₁₀, a set of receptors resulting from a mammalian-specific internal duplication, see ENSMUSP00000133122, were assigned to P₂RY_{10B}.

GPR20,31; HCAR1,2,3; OXER1. Near GPR₂₀ we suggest a new orphan, divided into two subtypes: a group of constituted of gar/fishes(6)/reptiles(3)/monotreme(1), see ENSLOCP0000001967, named here GPR_{207A}; and gar/coelacanth(duplicated), see ENSLOCP00000021450, named GPR_{207B}. A set of fishes(21), see ENSLOCP00000021469, is probably orthologous to the mammalian oxoecosanoid receptor 1 (OXER1); in such case a set of fish/amphibian(2) genes, see ENSLOCP00000020331, is paralogous. The subtypes 1–3 of the hydroxycarboxylic acid receptors HCA, found only in mammals, are closely related and thus the likely result of recent duplications. Two sets of fishes are branched to the mammalian subtypes, of which gar/fishes(8)/coelacanth, see ENSLOCP00000022252, was named HCAR₁₁.

GPR34,82,87,171; P2RY12,13,14. P₂RY₁₃ has an extra set of fishes(3), see ENSLOCP00000002272, indicating an internal duplication. Near GPR₃₄ there are two groups of sequences: one gar/fishes(41, many duplicates), see ENSLOCP00000021478, named here GPR₂₀₆; another set with gar/fish/amphibian/sauropsids(5), see ENSLOCP00000016952, was named GPR_{34B}.

SUCNRI; OXGRI; P2RY1,2,4,6; GPR17; GPR183; CYSTLR1,2. Branched distantly from others is a new orphan divided into three sets: two with genes from gar(2)/coelacanth/reptile, see ENSACAP00000008615, named GPR_{205C} and GPR_{205B}; the second gar/fishes(9)/coelacanth/amphibian/sauropsids(4), see ENSACAP00000013831, named GPR_{205A}. Near P₂RY₁ (NPSR₁ in R.95) there is a cluster of genes from gar/fishes(23)/coelacanth/amphibian(triplicates)/sauropsids(7), see ENSLOCP00000022457, that we named NPSR_{1L}. Near P₂RY₆ there are two sets of unannotated genes: a complete group with gar/fishes(3)/coelacanth/reptile(1)/mammals(21), see ENSLOCP00000021492, named here P₂RY₁₆; and, distant and rooted by duplicated lampreys (see ENSMAP00000011278), a cluster comprised of gar/fishes(18, duplicates)/coelacanth/amphibian, see ENSLOCP00000021662, that we named GPR₂₀₄. A set of genes from ray-finned fishes(10)/coelacanth(duplicated)/sauropsids(5)/mammals(5), including one monotreme and one marsupial, see ENSLOCP00000021877, was assigned as GPR₁₉₇. A gar/fishes(8) specific group of genes, see ENSLOCP00000014291, is branched near GPR₁₇, and we named it GPR_{17B}. Another group rooted by lamprey (triplicate, ENSMAP00000011192) comprised of gar/fishes(4)/coelacanth, see ENSMAP00000011192, was named CYSLTR_{3A}. Two other fishes (gar, cave fish) nearby open the possibility of another subtype CYSLTR_{3B}.

FFAR_{1,2,3}. Free fatty acid receptors (FFAR) have generally undergone many internal duplications. A small gene cluster from coelacanth/amphibian/reptile, see ENSLACP00000002775, is likely a new new subtype FFAR_{2#} (annotation in process). A set of 32 genes from fishes, see ENSLOCP00000006360, is likely belonging to FFAR_{2#} (Ensembl.R92).

GPR141; GPR101,161,176. These two clusters of orphan receptors were initially aggregated with PURIN receptors but form independent groups in Ensembl.R92. A set containing gar/fishes(10)/coelacanth, see ENSLOCP00000014127, was named GPR_{141C}. A set with coelacanth/sauropsids(4)/mammals(15, including two monotremes), see ENSLACP00000005080, was named GPR_{141B}. A set of fishes(10)/amphibian, see ENSXETP00000035434, was named GPR₁₉₈.

Other families. We grouped together receptors that we could not link to the main families, and in this group we identify seven novel receptors (Fig. 6). Interestingly, nine of the orphan groups are closely associated with a lamprey or tunicate sequence, showing an ancient origin; and there are clear grouping for some of the orphans into subtype groups.

GPR22. A set from gar/fishes(17,duplicated)/coelacanth/amphibian/reptile/marsupial, see ENSLOCP00000017943, is a new subtype GPR_{22L}, which may divide further into different subtypes.

GPR139; GPR142. Three sets of genes indicate an orphan divided into three subtypes: coelacanth/fishes(4), see ENSLACP00000014196, named here GPR_{210A}; gar/coelacanth, see ENSLACP00000019189 (not in R.95); gar/fishes(2)/coelacanth, see ENSLACP00000015589, named GPR_{210B}.

GPER1. A new subtype in ray-fin fishes (8) has been previously reported, which may be a fish-specific duplicate (3R)⁹⁰.

GPR20. An independent group of fishes(8), see ENSAMXP00000025847, was named GPR₂₀₈; a set of fishes(10)/coelacanth/amphibian/sauropsids(7)/marsupial/monotreme genes, see ENSAMXP00000019172, is distant

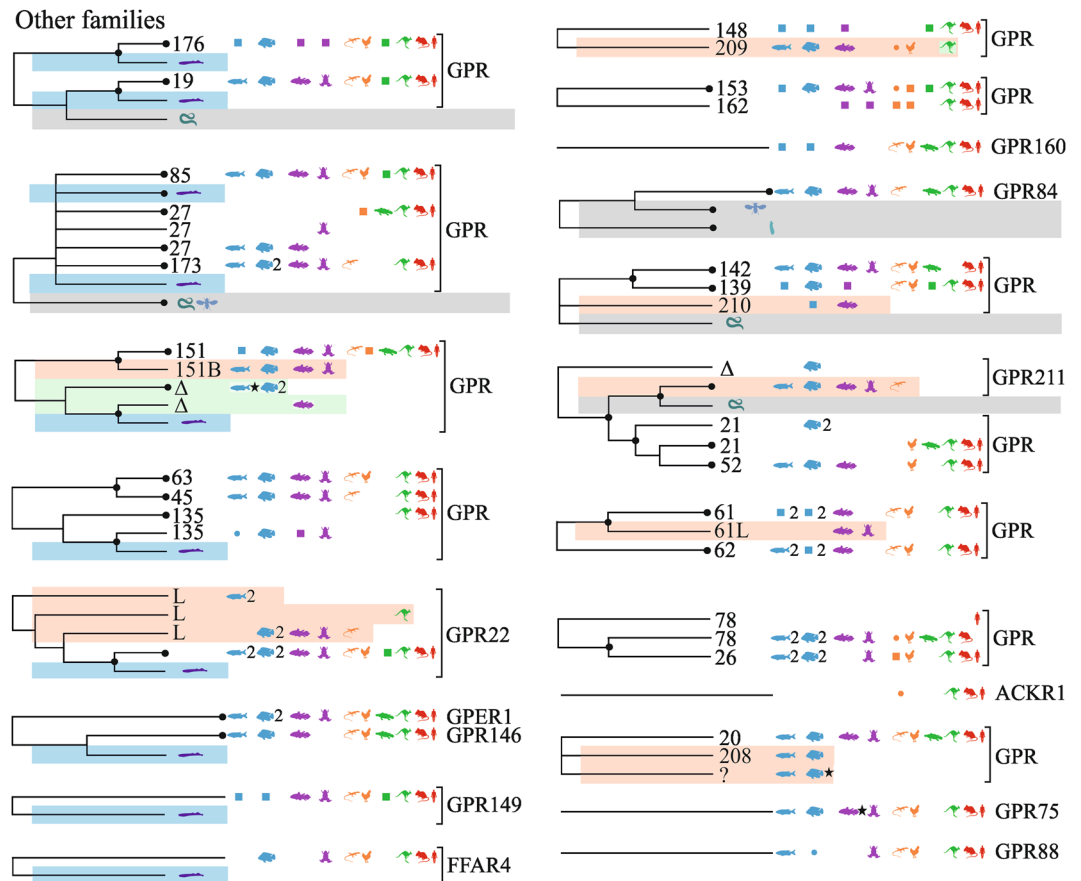

Figure 6. Overview of vertebrate GPCR clades mapped onto neighbor-joining trees for orphans without clear families. Caption otherwise similar to that of Fig. 1.

from GPR₂₀'s placental mammals and may represent a new subtype. A group of gar/fishes(15) is also nearby in Ensembl.R92 (annotated lpar5b), see ENSLOCP00000021496.

GPR151. A set of fishes(9)/coelacanth/amphibian, see ENSLACP00000009338, was named GPR_{151B}.

GPR148. A set of fish(2)/sauropsids(5)/marsupial(1), see ENSLOCP00000021506, was named GPR₂₀₉. A second spotted gar, see ENSLOCP00000021505, may indicate another subtype.

GPR61. A set coelacanth/ambiphan, see ENSLACP00000015922, is likely paralogous to GPR₆₂.

GPR21,52. A set of gar/fishes(10)/coelacanth/amphibian/lizard, see ENSLACP00000013616, named GPR₂₁₁.

Conservation across families. We used the set of sequences aligned across families to study the relative conservation of the subtypes across four representative species (human, mouse, bird, amphibian and fish) (see Supporting information; 189 aligned positions). Generally, as expected the more “ancient” branches such as α -branch and β -branch are relatively conserved compared to more recent branches (χ -branch and δ -branch). In the α -branch (Fig. 7A,B), the most conserved are LPAR₁ and CNR₁ in MECA that share sequence identity above 90% towards their human orthologue (human-zebrafish LPAR₁, 96%; human-mouse LPAR₁, 99%; human-zebrafish CNR₁ 92% and human-mouse CNR₁ 99%). Conservation is also high in the AMIN family (Fig. 7A) where the DRD_{1/2}, ADRA_{2C} and CHR_{M3/4/5} have percent sequence identities above 90% towards the human receptors. In the β -branch, in PEP GPR₂₂ and HCRTR₂ maintain sequence identity above 90% from amphibian to mouse (Fig. 7C). Few receptors of the γ -branch maintain sequence identity above 80% through species (Fig. 7D), but this is the case of OPRD₁, OPRK₁, GALR₁ and SSTR₁ (most conserved OPRM₁, human-zebrafish 93%; human-mouse 99%). In the δ -branch conservation is less (Fig. 7E), and the most conserved are TSHR (80–93%) and P2RY₁ (81–98%). In the unassigned receptors (Fig. 7F), GPER₁ is the most conserved (human-zebrafish 87%; human-mouse 95%). Not surprisingly, GPR₈₅ (human-zebrafish, 94%; human-mouse, 100%), an orphan receptor closely related to the amine family and named “Super Conserved Receptor” shows a very high conservation too (initially grouped with AMIN, Fig. 7A).

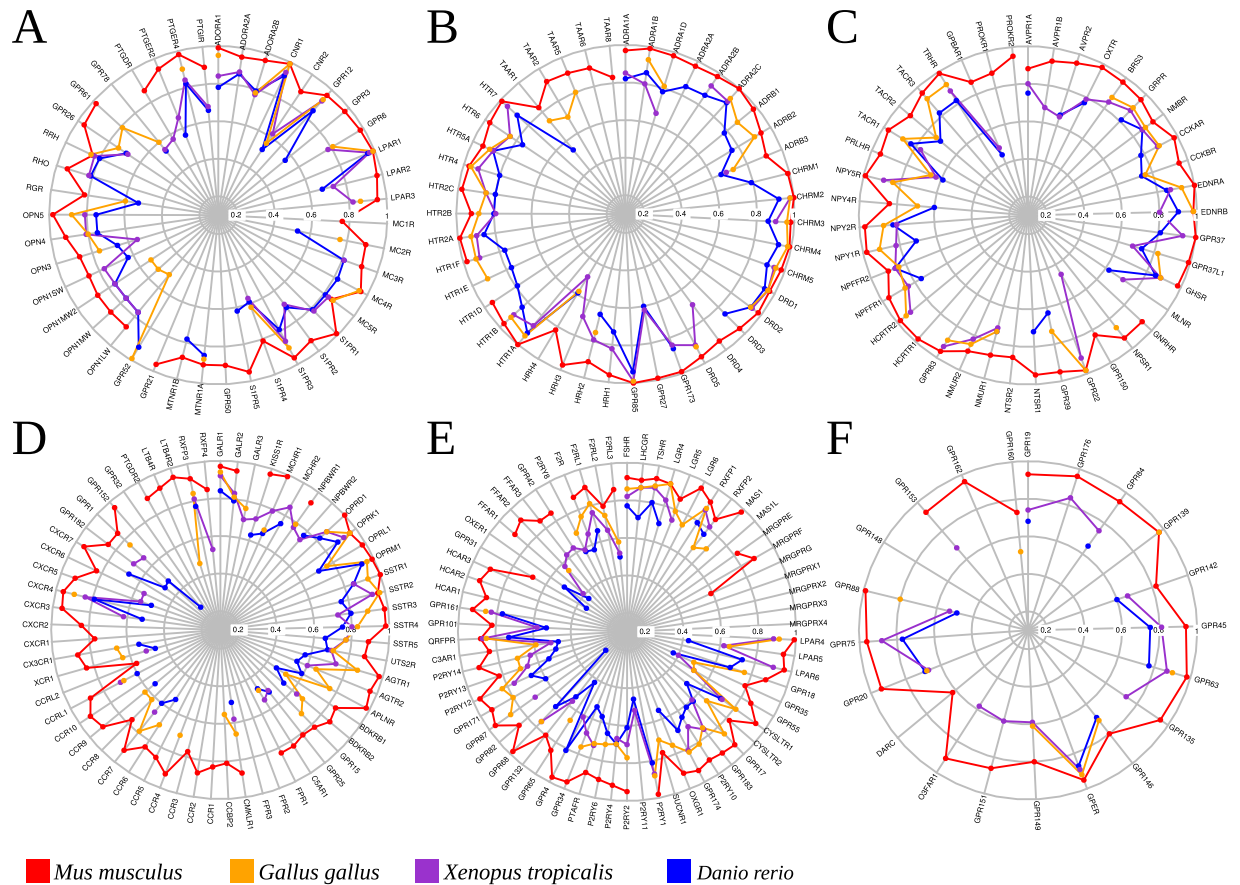

Figure 7. Percent sequence identity (189 aligned positions) to their human orthologues for four representative species: mouse (*Mus musculus*), chicken (*Gallus gallus*), western clawed frog (*Xenopus tropicalis*) and zebrafish (*Danio rerio*). (A,B), α - (C), β - (D), γ - (E) δ - branches and (F) other families.

Concluding remarks. The novel receptors are identified based on sequence data alone. The complete integrity of the sequences, validated by the conserved GPCR motifs, suggest that these are not pseudogenic. The groupings have been highly stable during the last five years, especially inside monophyletic groups, and most likely to remain so. Generally, the branchings in the fast-evolving PUR and CHEM families (see eg especially near FRP_{1,2,3} and GPR_{32,33}), and for distant sequences such as lamprey, have been the most rearranged over the different Ensembl releases. The automated rearrangements have been nonetheless parsimonious, ie groups have been reassigned as orthologues rather than paralogues of known receptors.

This study raises numerous nomenclature issues, but in the same time sets a framework on the extent of yet-to-be studied vertebrate receptors. A difficult issue is that without establishing ligand binding preferences new sequences cannot be defined as “subtypes” or “orphan” receptors; we thus chose to keep the “subtype” denomination only for the likely cases. Importantly, the ligand binding preferences are not fully indicative of close evolutionary relationships; some receptors have acquired the same ligand specificity several times, for example α_1 -, α_2 -, and β -adrenoceptors^{31,32}.

This study maps the extent of orthologues of human GPCRs to vertebrate species. Furthermore, it explores the pool of yet-to-be-studied GPCRs, suggesting at minima 69 sets of novel receptors in vertebrates not orthologous to human. The clustering data allows to group orphan receptors and thus probably brings down the number of endogenous ligands yet to be identified. Nineteen of these groups are maintained in Ensembl.R92 and thus worthy of consideration: In MECA, GPR3/6/12; in PEP, GPR83/165, EDNR/GPR37/37L1, GPR39/NTSR; in CHEM, GPR15/25, GPR182/ACK3; in PUR, GPR20/35/55, GPR101/161, P2RY10/GPR174, GPR17/183, GPR87/P2RY14, GPR31/HCAR; and in other families GPR85/27/173, GPR45/63/135, GPR153/162, GPR139/142, GPR21/52, GPR61/62, GPR26/78; for a few of these receptors an endogenous ligand has been suggested⁹¹. The data at the basis of this study are available online (see the Experimental section) and will continue to be improved following especially the sequencing of novel genomes and the increased coverage of existing genomes.

Experimental Section

Ensembl data. The Ensembl.R90 includes 89 vertebrate genomes: eleven ray-finned fishes (e.g. zebrafish, spotted gar), one lobe-finned fish, one amphibian, five birds, two reptilians, three marsupial, one monotreme and 65 eutherian mammals, as well as early vertebrates (lamprey, two tunicates) and invertebrates (one insect and one nematode). The most recent release, Ensembl.R92, includes 94 genomes.

New receptors were identified based on the branching presented on the Ensembl-generated trees. Three genomes are at the cornerstone for assessing a new receptors: coelacanth, frog, and spotted gar, and we separate them (“spotted gar” referred to simply as “gar”) from the other fishes. Spotted gar diverged from the teleost lineage before the 3R⁹²). New orphan receptors were named in numerical order starting from 181, using the numbers left empty (for human genes) by the HUGO Gene Nomenclature Committee. New subtypes were identified either numerically or alphabetically.

Guide trees. The data used to build the guide trees are based on an automatically extracted and curated set of 14,000 sequences is described as Supporting Information. This earlier data are used in this manuscript only to build guide trees and compute sequence identities in transmembrane regions.

Data Accessibility

All genomic data from the Ensembl releases is freely accessible online in few simple steps: (1) log to <http://www.ensembl.org> or to the Ensembl archives <https://www.ensembl.org/info/website/archives/index.html> (2) query the name of the receptor of interest or the provided codes; (3) select (usually) the first Gene hit on the list; (4) click on “gene tree” in the left-hand panel; (5) browse the tree data: in particular, branches can be expanded and sequences visualized. The sequence data used to construct the guide trees is accessible upon request. Note added following acceptance: The genes identified in this manuscript have been submitted to the HGNC, and will be submitted to the MGNC, RGNC, XNC, and ZNC nomenclature committees on publication.

References

- Ahonen, T. J. *et al.* Synthesis of 7 β -hydroxy-8-ketone opioid derivatives with antagonist activity at mu- and delta-opioid receptors. *Eur. J. Med. Chem.* **151**, 495–507 (2018).
- Leino, T. O. *et al.* Azulene-based compounds for targeting orexin receptors. *Eur. J. Med. Chem.* **157**, 88–100 (2018).
- Turku, A. *et al.* Pharmacophore Model To Discover OX₁ and OX₂ Orexin Receptor Ligands. *J. Med. Chem.* **59**, 8263–8275 (2016).
- Hauser, A. S., Attwood, M. M., Rask-Andersen, M., Schiöth, H. B. & Gloriam, D. E. Trends in GPCR drug discovery: new agents, targets and indications. *Nat. Rev. Drug Discov.* **16**, 829–842 (2017).
- Palczewski, K. *et al.* Crystal structure of rhodopsin: A G protein-coupled receptor. *Science* **289**, 739–45 (2000).
- Wang, C. *et al.* Structure of the human smoothed receptor bound to an antitumour agent. *Nature* **497**, 338–43 (2013).
- Isberg, V. *et al.* GPCRDB: an information system for G protein-coupled receptors. *Nucleic Acids Res.* **42**, D422–D425 (2014).
- Isberg, V. *et al.* Generic GPCR residue numbers – aligning topology maps while minding the gaps. *Trends Pharmacol. Sci.* **36**, 22–31 (2015).
- Ruuskanen, J. O. *et al.* Identification of duplicated fourth alpha2-adrenergic receptor subtype by cloning and mapping of five receptor genes in zebrafish. *Mol. Biol. Evol.* **21**, 14–28 (2004).
- Ballesteros, J. A. & Weinstein, H. [19] Integrated methods for the construction of three-dimensional models and computational probing of structure-function relations in G protein-coupled receptors. *Methods Neurosci.* **25**, 366–428 (1995).
- Fredriksson, R., Lagerström, M. C., Lundin, L.-G. & Schiöth, H. B. The G-Protein-Coupled Receptors in the Human Genome Form Five Main Families. Phylogenetic Analysis, Paralogue Groups, and Fingerprints. *Mol. Pharmacol.* **63**, 1256–1272 (2003).
- Fredriksson, R. & Schiöth, H. B. The Repertoire of G-Protein-Coupled Receptors in Fully Sequenced Genomes. *Mol. Pharmacol.* **67**, 1414–1425 (2005).
- Kolakowski, L. F. GCRDB: a G-protein-coupled receptor database. *Receptors Channels* **2**, 1–7 (1994).
- Krishnan, A., Almén, M. S., Fredriksson, R. & Schiöth, H. B. The origin of GPCRs: identification of mammalian like Rhodopsin, Adhesion, Glutamate and Frizzled GPCRs in fungi. *PLoS One* **7**, e29817 (2012).
- Bylund, D. B. *et al.* Pharmacological characteristics of alpha 2-adrenergic receptors: comparison of pharmacologically defined subtypes with subtypes identified by molecular cloning. *Mol. Pharmacol.* **42**, 1–5 (1992).
- Ohno, S. *Evolution by Gene Duplication*. (Springer Berlin Heidelberg, 1970), <https://doi.org/10.1007/978-3-642-86659-3>.
- Lundin, L. G. Evolution of the vertebrate genome as reflected in paralogous chromosomal regions in man and the house mouse. *Genomics* **16**, 1–19 (1993).
- Dehal, P. & Boore, J. L. Two Rounds of Whole Genome Duplication in the Ancestral Vertebrate. *PLoS Biol.* **3**, e314 (2005).
- García-Fernández, J. The genesis and evolution of homeobox gene clusters. *Nat. Rev. Genet.* **6**, 881–892 (2005).
- Lagman, D. *et al.* The vertebrate ancestral repertoire of visual opsins, transducin alpha subunits and oxytocin/vasopressin receptors was established by duplication of their shared genomic region in the two rounds of early vertebrate genome duplications. *BMC Evol. Biol.* **13**, 238 (2013).
- Yun, S. *et al.* Prevertebrate Local Gene Duplication Facilitated Expansion of the Neuropeptide GPCR Superfamily. *Mol. Biol. Evol.* **32**, 2803–17 (2015).
- Pasquier, J. *et al.* Molecular evolution of GPCRs: Kisspeptin/kisspeptin receptors. *J. Mol. Endocrinol.* **52**, T101–17 (2014).
- Amores, A. *et al.* Zebrafish hox clusters and vertebrate genome evolution. *Science* **282**, 1711–4 (1998).
- Meyer, A. & Van de Peer, Y. From 2R to 3R: evidence for a fish-specific genome duplication (FSGD). *Bioessays* **27**, 937–45 (2005).
- Steinke, D., Hoegg, S., Brinkmann, H. & Meyer, A. Three rounds (1R/2R/3R) of genome duplications and the evolution of the glycolytic pathway in vertebrates. *BMC Biol.* **4**, 16 (2006).
- Kamesh, N., Aradhya, G. K. & Manoj, N. The repertoire of G protein-coupled receptors in the sea squirt *Ciona intestinalis*. *BMC Evol. Biol.* **8**, 129 (2008).
- Escriva, H., Manzon, L., Youson, J. & Laudet, V. Analysis of lamprey and hagfish genes reveals a complex history of gene duplications during early vertebrate evolution. *Mol. Biol. Evol.* **19**, 1440–50 (2002).
- Kuraku, S., Meyer, A. & Kuratani, S. Timing of Genome Duplications Relative to the Origin of the Vertebrates: Did Cyclostomes Diverge before or after? *Mol. Biol. Evol.* **26**, 47–59 (2008).
- Hedges, S. B. & Kumar, S. A molecular timescale for vertebrate evolution. *Nature* **392**, 917–920 (1998).
- Lynch, M. & Conery, J. S. The evolutionary fate and consequences of duplicate genes. *Science* **290**, 1151–5 (2000).
- Vincent, J. D., Cardinaud, B. & Vernier, P. Evolution of monoamine receptors and the origin of motivational and emotional systems in vertebrates. *Bull. Acad. Natl. Med.* **182**, 1505–14; discussion 1515–6 (1998).
- Xhaard, H., Rantanen, V.-V., Nyrönen, T. & Johnson, M. S. Molecular evolution of adrenoceptors and dopamine receptors: implications for the binding of catecholamines. *J. Med. Chem.* **49**, 1706–19 (2006).
- Pertwee, R. G. GPR55: a new member of the cannabinoid receptor clan? *Br. J. Pharmacol.* **152**, 984–6 (2007).
- Nathans, J. & Hogness, D. S. Isolation, sequence analysis, and intron-exon arrangement of the gene encoding bovine rhodopsin. *Cell* **34**, 807–14 (1983).
- Dixon, R. A. F. *et al.* Cloning of the gene and cDNA for mammalian β -adrenergic receptor and homology with rhodopsin. *Nature* **321**, 75–79 (1986).

36. Gloriam, D. E., Fredriksson, R. & Schiöth, H. B. The G protein-coupled receptor subset of the rat genome. *BMC Genomics* **8**, 338 (2007).
37. Lagerström, M. C. *et al.* The G protein-coupled receptor subset of the chicken genome. *PLoS Comput. Biol.* **2**, e54 (2006).
38. Sarkar, A., Kumar, S. & Sundar, D. The G protein-coupled receptors in the pufferfish *Takifugu rubripes*. *BMC Bioinformatics* **12**(Suppl 1), S3 (2011).
39. Harding, S. D. *et al.* The IUPHAR/BPS Guide to PHARMACOLOGY in 2018: updates and expansion to encompass the new guide to IMMUNOPHARMACOLOGY. *Nucleic Acids Res.* **46**, D1091–D1106 (2017).
40. Yamamoto, K. *et al.* Evolution of Dopamine Receptor Genes of the D1 Class in Vertebrates. *Mol. Biol. Evol.* **30**, 833–843 (2013).
41. Hoyer, D. 5-HT Receptor Nomenclature: Naming Names, Does It Matter? A Tribute to Maurice Rappaport. *ACS Chem. Neurosci.* **8**, 908–919 (2017).
42. Flicek, P. *et al.* Ensembl 2012. *Nucleic Acids Res.* **40**, D84–D90 (2012).
43. Aken, B. L. *et al.* Ensembl 2017. *Nucleic Acids Res.* **45**, D635–D642 (2017).
44. Vernier, P., Cardinaud, B., Valdenaire, O., Philippe, H. & Vincent, J. D. An evolutionary view of drug-receptor interaction: the bioamine receptor family. *Trends Pharmacol. Sci.* **16**, 375–81 (1995).
45. Haug-Baltzell, A., Jarvis, E. D., McCarthy, F. M. & Lyons, E. Identification of dopamine receptors across the extant avian family tree and analysis with other clades uncovers a polyploid expansion among vertebrates. *Front. Neurosci.* **9**, 361 (2015).
46. Boehmler, W. *et al.* Evolution and expression of D2 and D3 dopamine receptor genes in zebrafish. *Dev. Dyn.* **230**, 481–93 (2004).
47. Ruuskanen, J. O. *et al.* Conserved structural, pharmacological and functional properties among the three human and five zebrafish α 2-adrenoceptors. *Br. J. Pharmacol.* **144**, 165–177 (2005).
48. Sourbron, J. *et al.* Serotonergic Modulation as Effective Treatment for Dravet Syndrome in a Zebrafish Mutant Model. *ACS Chem. Neurosci.* **7**, 588–98 (2016).
49. Matthes, H. *et al.* Mouse 5-hydroxytryptamine5A and 5-hydroxytryptamine5B receptors define a new family of serotonin receptors: cloning, functional expression, and chromosomal localization. *Mol. Pharmacol.* **43**, 313–9 (1993).
50. Nuckels, R. J., Forstner, M. R. J., Capalbo-Pitts, E. L. & Garcia, D. M. Developmental expression of muscarinic receptors in the eyes of zebrafish. *Brain Res.* **1405**, 85–94 (2011).
51. Lindemann, L. *et al.* Trace amine-associated receptors form structurally and functionally distinct subfamilies of novel G protein-coupled receptors. *Genomics* **85**, 372–85 (2005).
52. Gloriam, D. E. I. *et al.* The repertoire of trace amine G-protein-coupled receptors: large expansion in zebrafish. *Mol. Phylogenet. Evol.* **35**, 470–82 (2005).
53. Hashiguchi, Y. & Nishida, M. Evolution of trace amine associated receptor (TAAR) gene family in vertebrates: lineage-specific expansions and degradations of a second class of vertebrate chemosensory receptors expressed in the olfactory epithelium. *Mol. Biol. Evol.* **24**, 2099–107 (2007).
54. Rios-Cardona, D., Ricardo-González, R. R., Chawla, A. & Ferrell, J. E. A role for GPRX, a novel GPR3/6/12-related G-protein coupled receptor, in the maintenance of meiotic arrest in *Xenopus laevis* oocytes. *Dev. Biol.* **317**, 380–8 (2008).
55. Hisano, Y. *et al.* Comprehensive analysis of sphingosine-1-phosphate receptor mutants during zebrafish embryogenesis. *Genes Cells* **20**, 647–58 (2015).
56. Chinen, A., Hamaoka, T., Yamada, Y. & Kawamura, S. Gene duplication and spectral diversification of cone visual pigments of zebrafish. *Genetics* **163**, 663–75 (2003).
57. Sato, K. *et al.* Two UV-Sensitive Photoreceptor Proteins, *Opn5m* and *Opn5m2* in Ray-Finned Fish with Distinct Molecular Properties and Broad Distribution in the Retina and Brain. *PLoS One* **11**, e0155339 (2016).
58. Bellingham, J. *et al.* Evolution of melanopsin photoreceptors: discovery and characterization of a new melanopsin in nonmammalian vertebrates. *PLoS Biol.* **4**, e254 (2006).
59. Davies, W. I. L. *et al.* An extended family of novel vertebrate photopigments is widely expressed and displays a diversity of function. *Genome Res.* **25**, 1666–79 (2015).
60. Iwasaki, R. *et al.* Molecular and pharmacological characterization of zebrafish ‘contractile’ and ‘inhibitory’ prostanoid receptors. *Biochem. Biophys. Res. Commun.* **438**, 353–358 (2013).
61. Reppert, S. M., Weaver, D. R., Cassone, V. M., Godson, C. & Kolakowski, L. F. Melatonin receptors are for the birds: molecular analysis of two receptor subtypes differentially expressed in chick brain. *Neuron* **15**, 1003–15 (1995).
62. Kaiya, H., Mori, T., Miyazato, M. & Kangawa, K. Ghrelin receptor (GHS-R)-like receptor and its genomic organisation in rainbow trout, *Oncorhynchus mykiss*. *Comp. Biochem. Physiol. A. Mol. Integr. Physiol.* **153**, 438–50 (2009).
63. Kaiya, H., Miura, T., Matsuda, K., Miyazato, M. & Kangawa, K. Two functional growth hormone secretagogue receptor (ghrelin receptor) type 1a and 2a in goldfish, *Carassius auratus*. *Mol. Cell. Endocrinol.* **327**, 25–39 (2010).
64. Mekuchi, M. *et al.* Molecular cloning, gene structure, molecular evolution and expression analyses of thyrotropin-releasing hormone receptors from medaka (*Oryzias latipes*). *Gen. Comp. Endocrinol.* **170**, 374–80 (2011).
65. Bidaud, I. *et al.* Distribution of the mRNAs encoding the thyrotropin-releasing hormone (TRH) precursor and three TRH receptors in the brain and pituitary of *Xenopus laevis*: effect of background color adaptation on TRH and TRH receptor gene expression. *J. Comp. Neurol.* **477**, 11–28 (2004).
66. Wang, Y. *et al.* Identification of the receptors for prolactin-releasing peptide (PrRP) and *Carassius* RFamide peptide (C-RFa) in chickens. *Endocrinology* **153**, 1861–74 (2012).
67. Fredriksson, R., Larson, E. T., Yan, Y.-L., Postlethwait, J.-H. & Larhammar, D. Novel neuropeptide Y Y2-like receptor subtype in zebrafish and frogs supports early vertebrate chromosome duplications. *J. Mol. Evol.* **58**, 106–14 (2004).
68. Fredriksson, R., Sjödin, P., Larson, E. T., Conlon, J. M. & Larhammar, D. Cloning and characterization of a zebrafish Y2 receptor. *Regul. Pept.* **133**, 32–40 (2006).
69. Larsson, T. A. *et al.* Early vertebrate chromosome duplications and the evolution of the neuropeptide Y receptor gene regions. *BMC Evol. Biol.* **8**, 184 (2008).
70. Larhammar, D. & Bergqvist, C. A. Ancient Grandeur of the Vertebrate Neuropeptide Y System Shown by the Coelacanth *Latimeria chalumnae*. *Front. Neurosci.* **7**, 27 (2013).
71. Ocampo Daza, D., Lewicka, M. & Larhammar, D. The oxytocin/vasopressin receptor family has at least five members in the gnathostome lineage, including two distinct V2 subtypes. *Gen. Comp. Endocrinol.* **175**, 135–43 (2012).
72. Kim, D.-K. *et al.* Revisiting the evolution of gonadotropin-releasing hormones and their receptors in vertebrates: secrets hidden in genomes. *Gen. Comp. Endocrinol.* **170**, 68–78 (2011).
73. Tello, J. A., Wu, S., Rivier, J. E. & Sherwood, N. M. Four functional GnRH receptors in zebrafish: analysis of structure, signaling, synteny and phylogeny. *Integr. Comp. Biol.* **48**, 570–87 (2008).
74. Hyndman, K. A., Miyamoto, M. M. & Evans, D. H. Phylogeny, taxonomy, and evolution of the endothelin receptor gene family. *Mol. Phylogenet. Evol.* **52**, 677–687 (2009).
75. DeVries, M. E. *et al.* Defining the origins and evolution of the chemokine/chemokine receptor system. *J. Immunol.* **176**, 401–15 (2006).
76. Okuno, T., Ishitani, T. & Yokomizo, T. Biochemical characterization of three BLT receptors in zebrafish. *PLoS One* **10**, e0117888 (2015).

77. Chadzinska, M., Golbach, L., Pijanowski, L., Scheer, M. & Verburg-van Kemenade, B. M. L. Characterization and expression analysis of an interferon- γ 2 induced chemokine receptor CXCR3 in common carp (*Cyprinus carpio* L.). *Dev. Comp. Immunol.* **47**, 68–76 (2014).
78. Ni, L.-Y. *et al.* Identification and expression analysis of three XCR1-like receptors from *Epinephelus coioides* after *Cryptocaryon irritans* infection. *Fish Shellfish Immunol.* **67**, 95–102 (2017).
79. Good, S., Yegorov, S., Martijn, J., Franck, J. & Bogerd, J. New Insights into Ligand-Receptor Pairing and Coevolution of Relaxin Family Peptides and Their Receptors in Teleosts. *Int. J. Evol. Biol.* **2012**, 1–14 (2012).
80. Yegorov, S. & Good, S. Using paleogenomics to study the evolution of gene families: origin and duplication history of the relaxin family hormones and their receptors. *PLoS One* **7**, e32923 (2012).
81. Elphick, M. R., Mirabeau, O. & Larhammar, D. Evolution of neuropeptide signalling systems. *J. Exp. Biol.* **221**, jeb151092 (2018).
82. Tostivint, H. *et al.* Molecular Evolution of Gpcrs: Somatostatin/urotensin II receptors. *J. Mol. Endocrinol.* **52**, T61–T86 (2014).
83. Mizusawa, K. *et al.* Molecular cloning and expression of two melanin-concentrating hormone receptors in goldfish. *Peptides* **30**, 1990–6 (2009).
84. Kobayashi, Y., Hamamoto, A., Hirayama, T. & Saito, Y. Molecular cloning, expression, and signaling pathway of four melanin-concentrating hormone receptors from *Xenopus tropicalis*. *Gen. Comp. Endocrinol.* **212**, 114–123 (2015).
85. Nocillado, J. N. *et al.* The Kiss2 receptor (Kiss2r) gene in Southern Bluefin Tuna, *Thunnus maccoyii* and in Yellowtail Kingfish, *Seriola lalandi* - functional analysis and isolation of transcript variants. *Mol. Cell. Endocrinol.* **362**, 211–20 (2012).
86. Ho, J. C. W., Jacobs, T., Wang, Y. & Leung, F. C. Identification and characterization of the chicken galanin receptor GalR2 and a novel GalR2-like receptor (GalR2-L). *Gen. Comp. Endocrinol.* **179**, 305–12 (2012).
87. Martins, R. S. T. *et al.* Novel galanin receptors in teleost fish: Identification, expression and regulation by sex steroids. *Gen. Comp. Endocrinol.* **205**, 109–120 (2014).
88. Maugars, G. & Dufour, S. Demonstration of the Coexistence of Duplicated LH Receptors in Teleosts, and Their Origin in Ancestral Actinopterygians. *PLoS One* **10**, e0135184 (2015).
89. Bader, M., Alenina, N., Andrade-Navarro, M. A. & Santos, R. A. Mas and Its Related G Protein-Coupled Receptors, Mrgprs. *Pharmacol. Rev.* **66**, 1080–1105 (2014).
90. Pinto, P. I. S. *et al.* Duplicated membrane estrogen receptors in the European sea bass (*Dicentrarchus labrax*): phylogeny, expression and regulation throughout the reproductive cycle. *J. Steroid Biochem. Mol. Biol.*, <https://doi.org/10.1016/j.jsbmb.2017.12.019> (2017).
91. Alexander, S. P. *et al.* The concise Guide to Pharmacology 2017/18: G protein-coupled receptors. *Br. J. Pharmacol.* **174**(Suppl 1), S17–S129 (2017).
92. Pasquier, J. *et al.* Evolution of gene expression after whole-genome duplication: New insights from the spotted gar genome. *J. Exp. Zool. Part B Mol. Dev. Evol.* **328**, 709–721 (2017).

Acknowledgements

This work was financially supported by Waldemar von Frenckells and Oskar Öflunds foundations (M.R.), by a grant from Higher Education Commission (HEC) of Pakistan under the indigenous Ph.D. program (074-1844-PS4-406) (ZUR. T.) and by the University of Helsinki internal funding (H.X.). Dr Elspeth Bruford from the HUGO nomenclature committee is thanked for the initial assessment of the suggested gene symbols, an input that helped improve the manuscript. Dr Vigneshwari Subramanian is thanked for the R scripts used to create Figure 7. The Drug Discovery and Chemical Biology Consortium is thanked for organizing the computational infrastructure in the Xhaard group. CSC-IT is thanked for providing access to supercomputing resources. The European COST action (CA18133, ERNEST) is thanked for organizing a network of GPCR researchers.

Author Contributions

Sequence retrieval and bioinformatics Z.U.R.T., A.K., H.X.; Data analysis, M.R., H.X.; Prepared the Figures and Tables, M.R.; Drawn the pictograms, M.R.; Wrote the manuscript (main contribution), M.R., H.X., Study design, H.X.

Additional Information

Supplementary information accompanies this paper at <https://doi.org/10.1038/s41598-018-33120-8>.

Competing Interests: The authors declare no competing interests.

Publisher's note: Springer Nature remains neutral with regard to jurisdictional claims in published maps and institutional affiliations.



Open Access This article is licensed under a Creative Commons Attribution 4.0 International License, which permits use, sharing, adaptation, distribution and reproduction in any medium or format, as long as you give appropriate credit to the original author(s) and the source, provide a link to the Creative Commons license, and indicate if changes were made. The images or other third party material in this article are included in the article's Creative Commons license, unless indicated otherwise in a credit line to the material. If material is not included in the article's Creative Commons license and your intended use is not permitted by statutory regulation or exceeds the permitted use, you will need to obtain permission directly from the copyright holder. To view a copy of this license, visit <http://creativecommons.org/licenses/by/4.0/>.

© The Author(s) 2019