

# Immunization with Soluble BDC 2.5 T Cell Receptor-Immunoglobulin Chimeric Protein: Antibody Specificity and Protection of Nonobese Diabetic Mice against Adoptive Transfer of Diabetes by Maternal Immunization

By Una McKeever,\* Sanjay Khandekar,\* John Newcomb,\* Jerome Naylor,\* Paul Gregory,\* Pamela Brauer,\* Michael Jesson,\* Brian Bettencourt,\* Erica Burke,\* Amy Alderson,\* Julian Banerji,\* Kathryn Haskins,<sup>†</sup> and Barry Jones\*

From \*Procept Incorporated, Cambridge, Massachusetts 02139; and the <sup>†</sup>Barbara Davis Center for Childhood Diabetes, Denver, Colorado 80262

## Summary

The BDC 2.5 T cell clone is specific for pancreatic  $\beta$ -cell antigen presented by I-A<sup>b7</sup>, and greatly accelerates diabetes when injected into 10–21-d-old nonobese diabetic (NOD) mice. The BDC 2.5 T cell receptor (TCR) has been solubilized as a TCR-IgG1 chimeric protein. All NOD mice immunized against BDC 2.5 TCR-IgG1 produced antibodies recognizing TCR  $\alpha$ /C $\beta$  epitopes that were inaccessible on the T cell surface. 56% of the mice produced antibodies against the BDC 2.5 clonotype that specifically blocked antigen activation of BDC 2.5 cells. We have used the adoptive transfer model of diabetes to demonstrate that maternal immunization with soluble TCR protects young mice from diabetes induced by the BDC 2.5 T cell clone.

As a result of the somatic recombination of TCR gene segments in developing T cells, each TCR contains some structural epitopes that are unique to a particular T cell clone and some that are shared among different clones (1). Immunity against a TCR could therefore regulate the function of either a specific T cell clone or a set of clones *in vivo*, depending on the nature of the epitope recognized. In the rat and mouse models of experimental autoimmune encephalomyelitis (EAE)<sup>1</sup>, oligoclonal suppression of autoreactive T cells appeared to occur after immunization with peptides derived from the  $\alpha$ - or  $\beta$ -chains of the TCR of encephalitogenic T cells. Immunization of Lewis rats with synthetic peptides based on the V $\beta$ -8.2 CDR2 (2) or V $\beta$ -D $\beta$ -J $\beta$  (3) sequences of the TCR of rat encephalitogenic T cells suppressed the induction of EAE. Immunization of B10.PL or (SJL  $\times$  B10.PL) F<sub>1</sub> mice with a peptide derived from framework region 3 of the TCR V $\beta$ -8.2 chain protected both strains against EAE (4, 5). Similar immunizations of DBA/2 or (PLJ  $\times$  SJL) F<sub>1</sub> mice with a V $\beta$ -8.2 CDR2 peptide appeared to induce clonal anergy in all V $\beta$ -8.2<sup>+</sup> T cells (6). The mechanism of regulation by TCR

peptide immunization is thought to involve primed CD4<sup>+</sup> (5) or CD8<sup>+</sup> (6) T cells that recognize the peptide in association with MHC molecules on the surface of either an APC or the autoreactive T cell itself (7). Although there are experimental data suggesting that T cells primed against the TCR V $\beta$ -8.2 CDR2 peptide can inhibit the activation of myelin basic protein-specific encephalitogenic rat T cells *in vitro* (8), the details and immunosuppressive effects of the mechanism are uncertain. T cells have yet to be shown to process their own TCR and present MHC-associated epitopes. Likewise, it is not known whether professional APC present TCR epitopes derived from autoimmune T cells in the course of disease. Furthermore, in rat EAE, immunization with the V $\beta$ -8.2 CDR2 peptide sometimes increased the severity of disease and converted the normally acute, self-limiting disease into a chronic disorder (9).

An alternative approach to immunotherapy is to perform TCR immunizations designed to induce antibodies against TCR variable region epitopes expressed on the T cell surface. The ability of injections of V $\beta$ -8.1/.2 family-specific mAb to prevent EAE in mice (10) suggests the feasibility of this approach. Although it has been shown that immunization with peptides representing TCR V $\beta$ -8.2 CDR2 (11), conserved VDJ, and consensus J $\alpha$  sequences (3) could stimulate the production of antibodies recognizing cell-surface TCR, V $\beta$ -8.2 CDR2 peptide immunization was not always successful in stimulating such a response in rats (9).

<sup>1</sup>Abbreviations used in this paper. dc, dual chain; EAE, experimental autoimmune encephalomyelitis; HRP, horseradish peroxidase; MOI, multiplicity of infection; NOD, nonobese diabetic; sc, single chain; SS<sup>-</sup>, cell surface staining negative; SS<sup>+</sup>, cell surface staining positive.

Moreover, several peptides based on the sequence of mouse TCR V $\beta$ -6 stimulated antibody responses against the peptides but not the intact TCR (12). To investigate immunoregulation resulting from an antibody response against TCR epitopes, a more reliable immunogen is required. Fortunately, newly developed techniques for the production of soluble TCR (13–16) now allow immunization with proteins containing the extracellular domains of the TCR. Such immunization should stimulate the immune system with an array of different T cell epitopes, some of which are likely to resemble those of native cell-surface TCR.

The BDC 2.5 T cell clone is I-A<sup>g7</sup>-restricted and specific for pancreatic islet  $\beta$ -cell antigen (17, 18). In vivo, it accelerates the onset of diabetes when injected into young nonobese diabetic (NOD) mice (19). We have produced soluble recombinant BDC 2.5 TCR by constructing a chimeric protein composed of the extracellular domains of the TCR chains (V $\alpha$ -1/C $\alpha$ , and V $\beta$ -4/C $\beta$ ) linked to the hinge, CH2 and CH3 domains of the mouse IgG1 heavy chain. The technique is similar to that used for the production of a  $\gamma/\delta$  TCR in transiently transfected COS cells (20); but we have used a baculovirus expression system shown previously to allow the successful production of soluble  $\alpha/\beta$  TCR from the D0-11.10 T cell hybridoma (21), and the N15 cytotoxic T lymphocyte clone (22).

The studies reported here characterize the immunological specificity of the antibody response to BDC 2.5 TCR-IgG1 protein in NOD mice. Unlike rat and mouse EAE, diabetes in the NOD mouse does not involve obviously restricted TCR V $\alpha$  or V $\beta$  gene segment usage (23), and it is extremely unlikely that immunization with a single TCR would affect the natural progression of disease. We have therefore investigated the ability of antibodies raised against BDC 2.5 TCR-IgG1 to protect against the adoptive transfer of diabetes by the BDC 2.5 T cell clone in young NOD mice. Because the recipient NOD mice are injected with BDC 2.5 cells between 10 and 21 d of age, they are too immature to be actively immunized. We have overcome this difficulty by immunizing female NOD mice and mating them. Their offspring have been investigated for the effect of maternally transferred anti-TCR antibodies on the diabetogenic activity of injected BDC 2.5 T cells.

## Materials and Methods

**Mice.** NOD mice were purchased from Taconic Farms (Germantown, NY), NOD/LtRIP-Tag transgenic mice (24) from the Animal Resources Unit of The Jackson Laboratory (Bar Harbor, ME), and AKR/J mice from The Jackson Laboratory. The RIP-Tag transgene is a recombinant simian virus 40 oncogene in which the rat insulin 5' promoter has been inserted immediately upstream of the simian virus 40 early region (25). Transgene expression is restricted to the  $\beta$ -cell and results in the formation of  $\beta$ -cell tumors in the pancreas in vivo. Offspring of crosses between NOD/Lt RIP-Tag and normal NOD mice were weaned and provided with 5% (wt/vol) sucrose-supplemented water, and sugar cubes. From 10 wk of age, blood glucose levels were closely monitored, and when the mice became severely hypoglycemic

(blood glucose concentration  $\leq$ 50 mg/dl) they were killed for islet cell preparation.

**T Cell Lines.** The pancreatic  $\beta$ -cell-specific, I-A<sup>g7</sup>-restricted, NOD mouse T cell clones, BDC 2.5 and 6.9, were propagated as previously described (17, 18) with the modification that x-irradiated (5,000 rads) islet cells isolated from NOD/LtRIP-Tag mice were substituted for conventional NOD mouse islets as a source of antigen. Before antigen-specific proliferation assays, BDC 2.5 and BDC 6.9 cells were rested for at least 14 d after the last stimulation with antigen and spleen cells. The T cell responses were assayed in U-bottomed 96-well plate cultures. Each well contained  $2 \times 10^4$  cloned T cell and  $5 \times 10^5$  x-irradiated (3,000 rads) NOD spleen cells as a source of APC in 200  $\mu$ l Eagle's Hank's amino acid medium (Irvine Scientific, Santa Ana, CA) supplemented with 5% FCS (Hyclone Laboratories, Logan, UT), 2 mM glutamine, 100 U/ml penicillin, 100 U/ml streptomycin, and  $5 \times 10^{-5}$  M 2-ME. Cultures were set up with and without  $7.5 \times 10^3$  x-irradiated (5,000 rads) islet cells as a source of antigen, incubated at 37°C in 5% CO<sub>2</sub> for 96 h, and pulsed with 1  $\mu$ Ci [<sup>3</sup>H]thymidine (6.7 Ci/mmol; ICN, Irvine, CA) for the final 16 h of incubation. The cultures were harvested, and isotope incorporation measured by scintillation counting. The mean counts per minute were calculated from triplicate cultures.

The isolation and in vitro propagation of the I-A<sup>k</sup>-restricted, hen egg conalbumin peptide-specific AKR mouse T cell clone, D10 (TCR V $\alpha$ -2/V $\beta$ -8.2), has been described previously (26). The B1 T cell line was derived from the spleen of an unimmunized NOD mouse. The B1 cells appear to be specific for an unidentified autoantigen of NOD spleen cells. Although no cloning procedure was used, 100% of the cells express TCR V $\beta$ -8.1/2 as determined by immunofluorescent staining. The B1 line was propagated in vitro similarly to the D10 line, except that x-irradiated NOD spleen cells were used as a source of antigen. The I-E<sup>k</sup>-restricted, pigeon cytochrome C peptide-specific mouse T cell clone, B10 (TCR V $\alpha$ -11/V $\beta$ -16), was kindly provided by Dr. S.M. Hedrick (Department of Biology, University of California, San Diego); it was propagated in vitro as described previously (27).

**Cloning of TCR and IgG1 Genes.** Total RNA was prepared from  $\sim 5 \times 10^6$  cells (28) and 1.0  $\mu$ g converted to single-stranded cDNA using superscript reverse transcriptase (GIBCO/BRL, Gaithersburg, MD) according to the manufacturer's protocol. TCR and IgG1 genes were amplified from 5% of each cDNA preparation in 75- $\mu$ l reactions containing: 10 mM Tris-HCl, pH 8.3, 50 mM KCl, 0.001% (wt/vol) gelatin, 1.5 mM MgCl<sub>2</sub>, 200 mM dNTPs, 2.5 U AmpliTaq DNA polymerase (Perkin Elmer Corp., Branchburg, NJ), and 270 nM of each primer. Primers were designed using published gene sequences encoding the TCR V $\beta$ -4, V $\alpha$ -1, C $\alpha$  and C $\beta$  segments, and the IgG1 heavy chain constant-region (23, 29, 30). The primer pairs for the BDC 2.5 TCR  $\beta$ -chain cDNA were: MusV $\beta$ -4, 5'-CCTCTAGAAGATCTCCATGGGCTCCATTTTCTCAGTT-3'; and 5'D10 $\beta$ , 5'-GGAATTCAGATCTCCGTCTAGTCGTGATGAACCA-CGAGGTACCAGATCAG-3'. The primer pairs for the BDC 2.5  $\alpha$ -chain cDNA were: MusV $\alpha$ -1, 5'CCTCTAGAAGATCTGCATGCATTCTTACATGTTTACTA-3'; and 5'D10 $\alpha$ , 5'-GGAATTCAGATCTGATGGAGCAGTCGTTGATCCACGTGGTACCAGGTC-3'. The primer pairs for the IgG1 hinge, CH2 and CH3 cDNA were: 5'-IgG1, 5'-GCTGGTACCAGGGGTAGTGGTTGTAAGCCTTGCATATGTACAGTCCCAGAAGA-3'; and 3'-IgG1, 5'GAAGATCTCATTACCA-GGAGAGTGGGAGAGGCTCTTCTC-3'. Cycling parameters were 95°C for 30s, 62°C for 30s, and 72°C for 60s for 30 cycles. PCR products were cloned into the vector pCRII (Invitrogen,

San Diego, CA) to yield the plasmids pCR-BDC25 $\alpha$ , pCR-BDC25 $\beta$ , and pCR-IgG1. The cloned genes were completely sequenced using Sequenase (United States Biochemicals, Cleveland, OH) and the manufacturer's protocol. They were found to be identical to published sequences (23, 31).

**Construction of Baculovirus Transfer Vectors.** Standard techniques were used for construction of recombinant DNA (32). p5/598 and p7/598 (Fig. 1 B) were constructed by ligating into either the BamHI or BglII sites of the polyhedrin/P10 'double-promoter' plasmid, pAcUW51 (Pharming, San Diego, CA), both a BglII-KpnI, BDC 2.5 TCR  $\beta$ -chain cDNA fragment from pCR-BDC25 $\beta$ , and a KpnI-BglII, IgG1 cDNA fragment from pCR-IgG1. Next, the BDC 2.5 TCR-IgG1 baculovirus transfer-vector p20/599 (Fig. 1 B) was made by ligating between the EcoRI and KpnI sites of p5/598 an EcoRI-BamHI fragment encoding the BDC 2.5 TCR  $\beta$ /IgG1 chimeric chain from p7/598, and two fragments from pCR-BDC25 $\alpha$ ; a BglII-PvuII fragment and a PvuII-KpnI fragment, which together encode the BDC 2.5 TCR  $\alpha$ -chain.

Two "single-promoter" recombinant transfer vectors with genes encoding BDC 2.5 TCR single  $\alpha$ - and  $\beta$ -chains as IgG1 chimeras downstream of the polyhedrin promoter were also constructed. p7/599 was constructed by ligating into the BamHI site of pVL941 both a BglII-KpnI BDC 2.5 TCR  $\alpha$ -chain cDNA fragment from pCR-BDC25 $\alpha$ , and the KpnI-BglII IgG1 fragment for pCR-IgG1. Similarly, p3/598 was constructed by ligating into the BamHI site of pVL941 (PharMingen) both the BglII-KpnI, BDC 2.5 TCR  $\beta$ -chain cDNA and the KpnI-BglII, IgG1 cDNA fragments.

Similar procedures were used to construct baculovirus transfer vectors encoding D10 TCR-IgG1 and D10 TCR-IgG1 proteins. The vectors encoding D10 dual chain (dc) TCR ( $\alpha$ / $\beta$ -heterodimer), and the D10 TCR individual  $\alpha$ - and  $\beta$ -chains will be described elsewhere (Khandekar, S.S., P.P. Brauer, J.W. Naylor, H.-C. Chang, P. Kern, J.R. Newcomb, K.P. LeClair, H.S. Stump, B.M. Bettencourt, E. Kawasaki, J. Banerji, A.T. Profy, and B. Jones, manuscript submitted for publication).

**Production of Soluble TCR in Insect Cells.** Sf9 cells were cotransfected with the recombinant transfer plasmid and linearized BaculoGold viral DNA according to the manufacturer's (PharMingen) recommendations. Standard procedures (33) were used to generate and amplify clonal isolates of recombinant virus. Recombinant viruses have been named after the transfer plasmid using v as the prefix.

To produce TCR-IgG1 protein for purification, Sf9 or High 5 (Invitrogen) cells were grown at 27°C in 6–8 l spinner cultures in serum-free SF900II medium (GIBCO/BRL) supplemented with 10 U/ml penicillin, 100  $\mu$ g/ml streptomycin, and 0.25  $\mu$ g/ml amphotericin B (Sigma Chemical Co., St. Louis, MO). When the cell concentration reached  $0.8\text{--}1.2 \times 10^6$ /ml the cultures were infected with recombinant baculovirus at a multiplicity of infection (MOI) of 5 and incubated for a further 3 d. Supernatants were harvested by centrifugation and filtration through a 0.2- $\mu$ m filter.

To compare the expression levels of soluble TCR during infection with different recombinant baculoviruses, small-scale infections were performed. Duplicate or triplicate 60-mm dishes were seeded with  $2 \times 10^6$  Sf9 cells in trichoplusia hi medium Fred Hank medium (JRH Sciences, Lenexa, KS). After the cells had attached (15–60 min) they were infected at a MOI of 5 with recombinant baculovirus. After 3 d the culture supernatants were harvested.

**Recombinant Proteins.** The production of D10 scTCR in *Es-*

*cherichia coli* will be described elsewhere (Khandekar, S.S., P.P. Brauer, J.W. Naylor, J.R. Newcomb, B.M. Bettencourt, J. Banerji, A.T. Profy, and B. Jones, manuscript in preparation). Baculovirus-derived, immunoaffinity-purified soluble CD4 was kindly donated by Dr. Marie-Rose van Schravendijk (Procept Inc., Cambridge, MA).

**Antibodies and Reagents.** Hybridomas producing the C $\beta$ -specific H57-597 mAb (34) and the TCR C $\alpha$ -specific H28 mAb (35) were kindly provided by Dr. Ellis Reinherz (Dana-Farber Cancer Institute, Boston, MA). FITC-conjugated, or biotinylated anti-C $\beta$  H57, anti-V $\beta$ -8.1/8.2, anti-V $\beta$ -6, anti-V $\alpha$ -2, and anti-V $\gamma$ -3 mAb were purchased from Pharmingen. FITC-conjugated anti-V $\beta$ -4 mAb was purchased from Harlan Bioproducts for Science (Indianapolis, IN), and FITC-conjugated goat anti-mouse Ig from Organon Teknika, Durham, NC. Alkaline phosphatase-conjugated streptavidin was purchased from Kierkegaard and Perry Laboratories, Gaithersburg, MD, and alkaline phosphatase-conjugated goat antibodies specific for mouse Ig  $\kappa$ - and  $\lambda$ -light chains from Southern Biotechnology Associates Inc., Birmingham, AL.

The hybridoma producing the TCR C $\beta$ -specific mAb, 501.1.1, was derived from the spleen of a NOD mouse that had been primed and boosted with soluble BDC 2.5 TCR-IgG1 as described below. 4 d after the final i.p. injection of antigen, the spleen cells were fused with P3X63-Ag8.653 myeloma cells (American Type Culture Collection, Rockville, MD) using standard procedures (36).

The D10 T cell clone-specific mAb 3D3 (26) was purified by protein A affinity chromatography.

**Immunoaffinity Chromatography.** 30 mg of mAb H57 were covalently coupled to 15 ml of protein A beads (Repligen, Cambridge, MA) using dimethylpimchmidate as described (37). Baculovirus-infected insect cell supernatants were concentrated approximately fivefold using a concentrator with a 10-kD membrane filter (Pellicon; Millipore, Bedford, MA), filtered through a 0.2- $\mu$ m filter, and passed over a H57-protein A column at 4°C with a flow rate of 1–2 ml/min. The column was washed with 10 column-volumes of PBS and eluted with 50 mM citrate, pH 3.0. Eluted fractions were neutralized with 1 M Tris-HCl, pH 8.8, and dialyzed against PBS. Protein concentrations were determined by the Bradford method (38), using BSA as a standard.

Using similar procedures, mAb 3D3-protein A columns were prepared and used to purify the soluble D10 TCR preparations: D10 dcTCR, D10 scTCR, and D10 TCR-IgG1 (Khandekar et al., manuscript submitted for publication). mAb H28 and H57 columns were used to purify soluble D10 TCR  $\alpha$ - and  $\beta$ -chain proteins.

**Immunoprecipitations, SDS-PAGE Analysis, and Immunoblotting.** BDC 2.5 TCR-IgG1 was precipitated by standard procedures (39) using an overnight 4°C incubation with 10  $\mu$ l anti-C $\alpha$  H28 or anti-C $\beta$  H57 mAb covalently coupled protein A beads.  $4 \times 10^7\text{--}6 \times 10^7$  T cells were lysed in TBS containing 0.2% NP-40 (Sigma Chemical Co.) and protease inhibitors (1 mM PMSF, N $\alpha$ -p-tosyl-L-lysine chloromethyl ketone, EGTA, and EDTA; 2  $\mu$ M leupeptin and pepstatin; 0.6 TIU/ml aprotinin; Sigma) at 10<sup>7</sup> cells/ml for 45 min on ice. Lysates were clarified by centrifugation and each lysate was incubated with 100  $\mu$ l of H57 mAb-coupled protein A beads for 4 h. Subsequent steps in the analyses of both BDC 2.5 TCR-IgG1 and T cell-derived TCR were similar. The beads were extensively washed with TBS containing either 0.5% Triton X-100 for recombinant TCR or 0.05% NP-40 for T cell-derived material, and the TCR proteins eluted by boiling in SDS sample buffer (2.3% SDS, 10% glycerol, 62.5 mM

Tris-HCl, pH 6.8) for 3 min, with or without 5% 2-ME. The eluted proteins were fractionated by 10.5% or 12.5% SDS-PAGE (40). Protein bands were stained with Coomassie brilliant blue. For Western blotting, proteins were separated by nonreducing SDS-PAGE, transferred directly to Immobilon-P membrane (Millipore), and probed with antisera or mAbs diluted in PBS. Antibody reactivity was detected with either polyspecific goat anti-mouse Ig antibody conjugated to horseradish peroxidase (HRP) (Cappel Laboratories, Durham, NC) or goat anti-hamster IgG-HRP (Cappel) at a 1:2,000 dilution. Western blots were visualized using the enhanced chemiluminescence technique (ECL; Amersham Corp., Arlington Heights, IL). In some experiments the membranes were stripped and reprobed according to the manufacturer's recommendations.

**Analysis of BDC 2.5 TCR-IgG1 by BIAcore.** The binding of TCR C $\alpha$ -specific H28 mAb and C $\beta$ -specific H57 mAb to BDC 2.5 TCR-IgG1 protein was analyzed using the BIAcore biosensor (Pharmacia LKB Biotechnology Inc., Piscataway, NJ). 0.6  $\mu$ g of immunoaffinity-purified BDC2.5 TCR-IgG1 was coupled to dextran surface by standard amine chemistry (41). A blank control surface was activated and blocked in the absence of soluble TCR. Affinity-purified H57 and H28 mAb (each at 3  $\mu$ M) were injected over a control surface or over the BDC 2.5 TCR-IgG1-coupled surface. The mAb were dialyzed against and diluted in Hepes-buffered saline (10 mM Hepes, 150 mM NaCl, 3.4 mM EDTA, 0.005% surfactant P20, pH 7.4). Samples of 20  $\mu$ l were injected at a flow rate of 5  $\mu$ l/min and this flow rate was maintained throughout the experiment. Where necessary, the biosensor surface was regenerated with 10 mM HCl. All binding experiments were conducted at 25°C. The surface plasmon resonance signal was recorded as resonance units versus time and the data plotted as a "sensogram."

**Immunofluorescence Staining and Flow Cytometry.** 10<sup>6</sup> T cells were incubated for 30 min on ice with FITC-labeled antibodies or NOD mouse nonimmune serum or antiserum diluted in 10  $\mu$ l PBS supplemented with 5% fetal bovine serum and 0.1% sodium azide. The cells were washed three times. After the antiserum incubation, the cells were incubated for a further 30 min on ice with FITC-labeled goat anti-mouse Ig antibody and again washed. In experiments designed to investigate the ability of NOD antiserum to block the binding of TCR-specific antibodies the cells were preincubated with antiserum in excess, washed three times, and stained with FITC-labeled anti-V $\beta$ -4 and anti-C $\beta$  mAb. The stained cells were fixed in 1% (wt/vol) paraformaldehyde in 0.85% saline, and analyzed on a FACScan<sup>®</sup> (Becton Dickinson and Co., San Jose, CA) equipped with LYSYS II software.

**ELISA.** The amounts of soluble heterodimeric BDC 2.5 TCR-IgG1 produced in the baculovirus expression system were estimated by a direct sandwich ELISA. 96-well plates (MaxiSorp; Nunc, Naperville, IL) were coated overnight with 4  $\mu$ g/ml TCR C $\beta$ -specific H57 mAb at 4°C, and blocked with 1% BSA in borate-buffered saline for 2 h at room temperature. 100- $\mu$ l samples of soluble TCR diluted in borate-buffered saline with 1% BSA were added overnight at 4°C. The plates were then washed and biotin-conjugated TCR C $\alpha$ -specific H28 mAb (1:500 dilution) was added to each well. After 4 h incubation at room temperature the plates were washed and developed with phosphatase-labeled streptavidin (Kirkegaard and Perry Labs, Gaithersburg, MD) and 104 substrate (Sigma Chemical Co.). The OD at 405 nm was measured and the amounts of soluble heterodimeric BDC 2.5 TCR-IgG1 were estimated by comparison of OD values with a standard curve obtained with a reference preparation of H57 mAb affinity-purified BDC TCR-IgG1 protein.

For the analysis of serum antibodies from mice immunized with soluble recombinant TCR, 96-well plates were incubated overnight at 4°C with soluble TCR preparations at a concentration of 4  $\mu$ g/ml in borate-saline buffer, pH 8.5. Plates were washed and blocked by standard procedures (42). The solid phase was incubated overnight at 4°C with NOD nonimmune serum or antiserum, or TCR-specific mAb, followed by an incubation with alkaline phosphatase-conjugated antibodies specific for mouse Ig  $\kappa$ - and  $\lambda$ -light chains. When TCR  $\alpha$ -chain, V $\beta$ -8, and V $\alpha$ -specific biotinylated mAb were used in the first step, alkaline phosphatase conjugated streptavidin was used instead of the anti-light chain antibodies. The binding of antibodies was measured as absorbance at 405 nm after reaction of the immune complexes with 104 phosphatase substrate (Sigma Chemical Co.).

**Immunizations.** NOD mice of 6–8 wk of age were primed by the subcutaneous injection into each hind limb of  $\sim$ 50  $\mu$ l of a 1:1 (vol/vol) emulsion of PBS and CFA (Sigma Chemical Co.) containing 200–300  $\mu$ g/ml of recombinant TCR protein. Where indicated, mice were boosted at least 14 d after priming, by the i.p. or i.v. injection of 20  $\mu$ g of recombinant protein in PBS into each animal. Mice were bled from the retroorbital sinus 4 d after the last boosting injection, and the sera were heat inactivated by incubation at 56°C for 30 min.

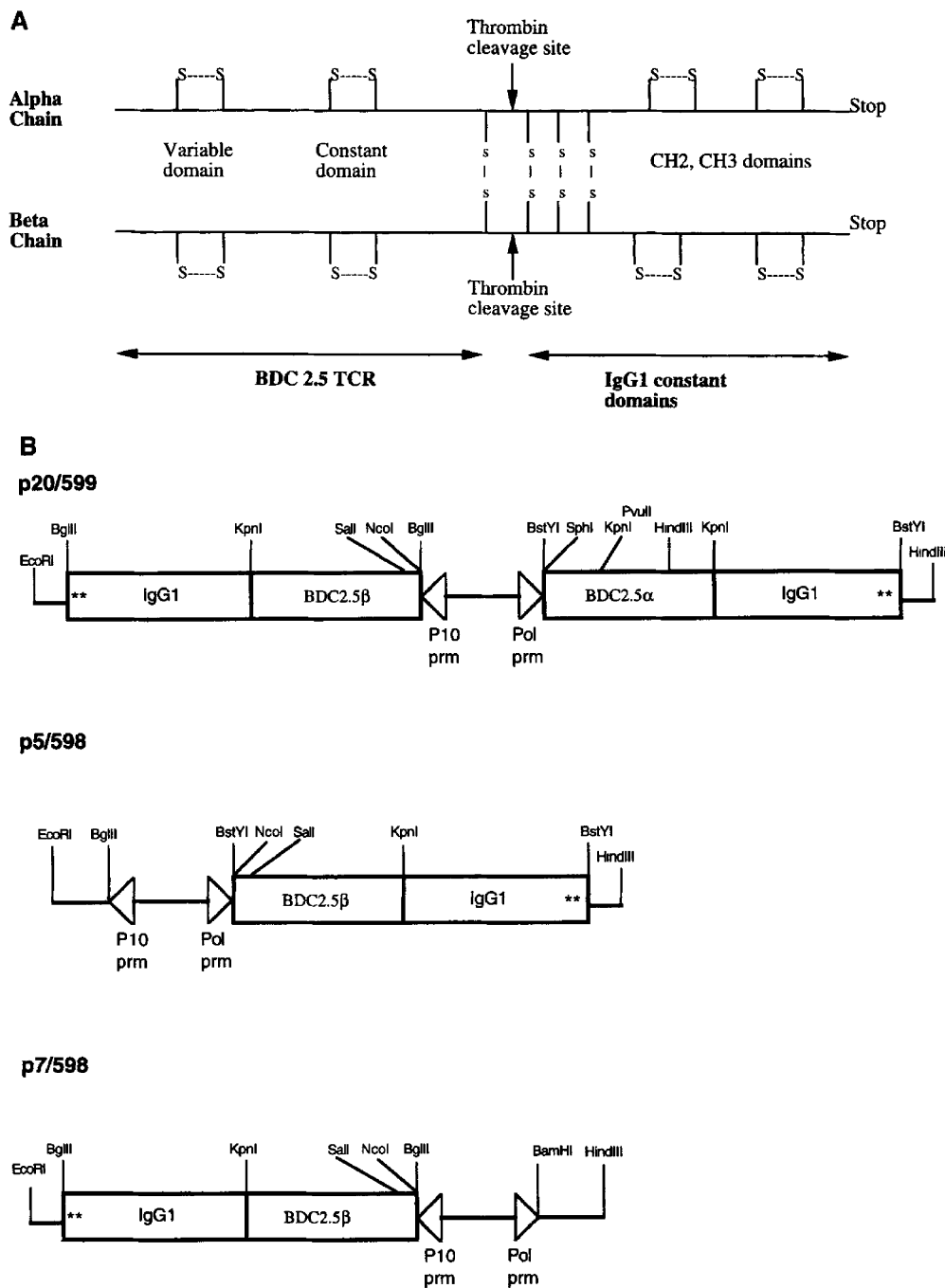
**Pancreatic Islet Isolation, and T Cell Purification.** Islet cells were isolated from (NOD/Lt RIP-Tag  $\times$  NOD) F<sub>1</sub> mouse pancreata as previously described (43), but with the modification that immediately after death the pancreas was infused with a collagenase (Boehringer Mannheim) solution (4.0 mg/ml) via the common bile duct. The pancreas was excised, incubated in vitro for 15 min at 37°C, and the encapsulated tumors dissected from exocrine tissue and forced through a 70- $\mu$ m nylon mesh (cell strainer; Falcon, Oxnard, CA) to produce a single cell suspension.

Normal mouse T cells were purified from spleen cells using T cell enrichment columns (R & D Systems, Minneapolis, MN) according to the manufacturer's instructions.

**Adoptive Transfer of Diabetes by BDC 2.5 and BDC 6.9 T Cell Clones.** The procedure was essentially that described previously (19). NOD mice between 10 and 21 d of age were injected with 5  $\times$  10<sup>6</sup> to 10  $\times$  10<sup>6</sup> T cells in a volume of 0.5 ml. A total of three injections spaced at weekly intervals was administered. Urinary sugar was monitored using test tape (Eli Lilly and Co., Indianapolis, IN) and the onset of diabetes was confirmed by measuring blood sugar levels with a Glucose Analyzer 2 (Beckman Instruments Inc., Palo Alto, CA). A blood sugar concentration of >10 mM indicated diabetes. Experiments were terminated as soon as diabetes was diagnosed or by 4 wk after the first injection of T cells.

## Results

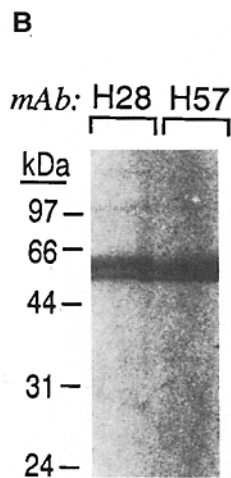
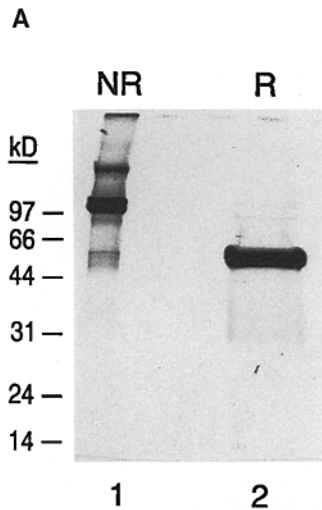
**Characterization of Soluble TCR-IgG1 Chimeric Receptors.** A schematic diagram of the TCR-IgG1 chimeric protein encoded by the recombinant baculovirus is shown in Fig. 1 A. TCR derived from the NOD mouse BDC 2.5 (TCR V $\alpha$ -1/V $\beta$ -4) T cell clone (18, 23) was expressed as a soluble TCR-IgG1 chimeric protein. Supernatants from Sf9 or High 5 cells infected with v20/599 (BDC 2.5 TCR-IgG1) recombinant baculovirus were fractionated by immunoaffinity chromatography on a TCR-C $\beta$ -specific, H57 mAb column. The bound and eluted BDC 2.5 receptor protein was analyzed by SDS-PAGE (Fig. 2 A). Under nonreduc-



**Figure 1.** The soluble BDC 2.5 chimeric protein and the baculovirus transfer vector encoding it. (A) Schematic of the BDC 2.5 TCR-IgG1 chimeric molecule. (B) Schematics showing the orientation of the TCR and IgG1 coding regions, and the polyhedrin and p10 promoters in the p20/599 transfer vector for the expression of BDC 2.5 TCR-IgG1. p5/598 and p7/598 were intermediate constructs used in making the transfer vectors. The construction of the vectors is described in Materials and Methods.

ing conditions, the purified receptor migrated as a major species of 110 kD, with a smaller amount of material at ~200 kD. After reduction, the protein showed a band at 50–55 kD, indicating that both nonreduced species were formed by the disulfide linkage of 50–55-kD subunits. The predicted molecular masses of the BDC 2.5 TCR  $\alpha$ -chain-IgG1 and  $\beta$ -chain-IgG1 polypeptides are 50,355 D and 55,319 D. The apparent molecular masses of 50–55 kD for the polypeptides are consistent with these values. Some variation in molecular mass of the recombinant protein is to be expected due to the variable high mannose-type

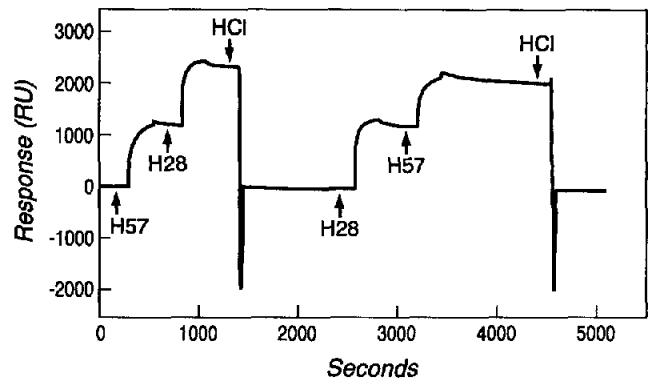
N-linked glycosylation which is known to modify recombinant proteins synthesized in baculovirus-infected insect cells (44–46). The data are also consistent with the major nonreduced 110-kD species being a dimer of a 50–55-kD subunit. The minor amounts of nonreduced species of higher molecular mass presumably represent oligomers formed by atypical disulfide bond formation. The presence of TCR  $\alpha$ - and  $\beta$ -chains in the immunoaffinity purified TCR-IgG1 protein was investigated by immunoprecipitation with  $C\alpha$ -specific H28 mAb, and  $C\beta$ -specific H57 mAb. Each antibody precipitated approximately equal amounts of



**Figure 2.** Analysis of NOD mouse soluble TCR-IgG1 chimeric proteins by SDS-PAGE. BDC 2.5 TCR-IgG1 protein was purified by immunoaffinity chromatography on an anti-C $\beta$  H57 mAb column. (A) BDC 2.5 TCR-IgG1 protein was analyzed by 12.5% SDS-PAGE under nonreducing (NR) and reducing (R) conditions (B) 20  $\mu$ l of immunoaffinity-purified BDC 2.5 TCR-IgG1 at a concentration of 0.75 mg/ml were precipitated with protein A-Sepharose beads coupled with H28 (anti-C $\alpha$ ) or H57 (anti-C $\beta$ ) mAb. The material eluted from the beads was analyzed by 12.5% SDS-PAGE under reducing conditions as described in Materials and Methods. The lanes are labeled with the protein A-Sepharose-coupled mAb used in the precipitation step. In (A) and (B) the protein bands were stained with Coomassie brilliant blue.

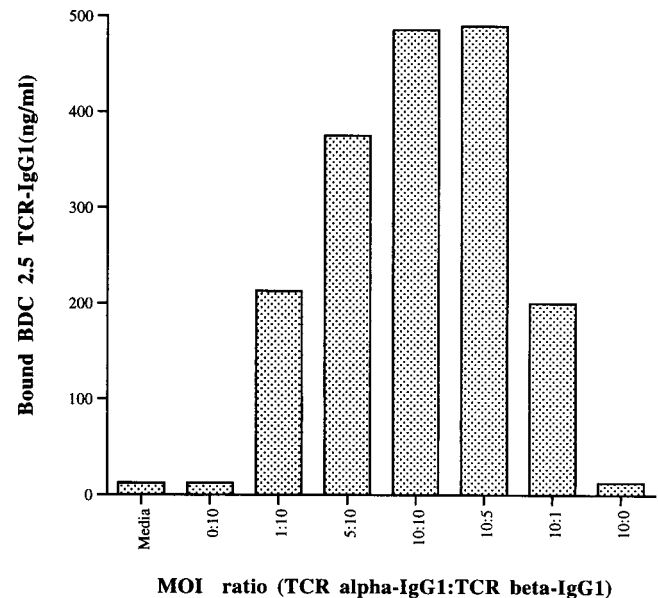
material which upon reduction yielded the 50–55-kD species (Fig. 2 B). The immunoprecipitations with H28- and H57-coupled beads were performed quantitatively. 20- $\mu$ l samples of H57-immunoaffinity purified BDC 2.5 TCR-IgG1 at a protein concentration of 0.75 mg/ml were precipitated with 10  $\mu$ l Sepharose beads that had been coupled with H28 or H57 mAb at a ratio of 2  $\mu$ g mAb/ml beads. Consequently, the approximately equal intensity of the H28- and H57-immunoprecipitated bands observed by SDS-PAGE (Fig. 2 B) indicated that the H57-immunoaffinity-purified material was mostly heterodimeric, although the presence of some aberrantly paired  $\alpha/\alpha$  and  $\beta/\beta$  homodimers could not be ruled out. The heterodimeric nature of the H57-immunoaffinity purified BDC 2.5 TCR-IgG1 was also indicated by the use of the BIAcore biosensor. Surface immobilized BDC 2.5 TCR-IgG1 bound both H57 and H28 mAb (Fig. 3). In this experiment the binding was confirmed by reversing the order of injection of the mAb after regeneration of the surface with 10 mM HCl. A control surface without immobilized TCR bound neither mAb (data not shown).

A direct sandwich ELISA similar to that described by Chang and colleagues (22) was developed for estimation of

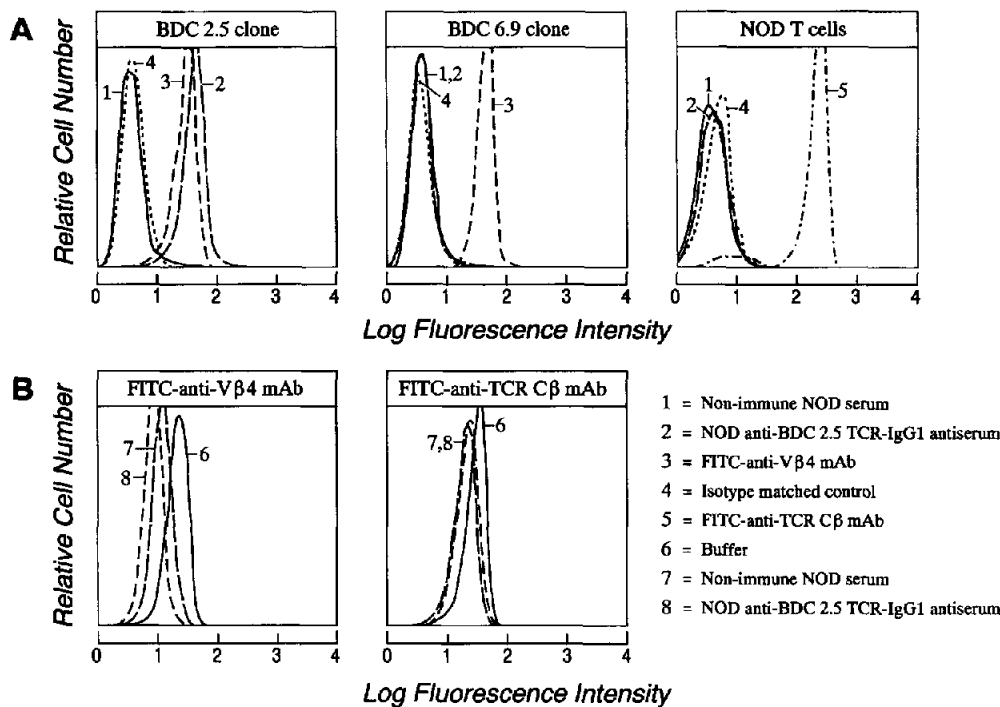


**Figure 3.** BIAcore biosensor measurement of the binding of H28 and H57 mAb to immobilized BDC 2.5 TCR-IgG1. Affinity-purified H57 and H28 mAb were sequentially injected at a concentration of 3  $\mu$ M over a surface coupled with 0.6  $\mu$ g immunoaffinity-purified BDC 2.5 TCR-IgG1 protein. The flow rate was 5  $\mu$ l/min. At the end of each binding cycle, the biosensor surface was regenerated with 10 mM HCl.

the yield of BDC 2.5 TCR-IgG1. Soluble TCR preparations or baculovirus culture supernatants were incubated on plates coated with C $\beta$ -specific mAb H57, and the captured TCR was detected with biotinylated C $\alpha$ -specific mAb H28 and phosphatase-labeled streptavidin. A standard curve was generated by the titration of a standard preparation of purified BDC 2.5 TCR-IgG1. Only heterodimeric soluble TCR should be detected by the ELISA. This was verified by the demonstration that no binding material was found in



**Figure 4.** Estimation of amounts of heterodimeric BDC 2.5 TCR-IgG1 by ELISA. Sf9 cells were infected with recombinant baculovirus at a MOI of  $5 \times 10^7$ /plate. Infections were with v7/599 (BDC 2.5 TCR  $\alpha$ -IgG1) alone, v3/598 (BDC 2.5 TCR  $\beta$ -IgG1) alone, or mixtures of the two. After incubation for 3 d, supernatants were harvested and the BDC 2.5 TCR-IgG1 assayed by ELISA as described in Materials and Methods. The ratios of the MOI of v7/599 to v3/598 used to infect the cells are shown on the abscissa.



**Figure 5.** NOD mice immunized with the BDC 2.5 TCR-IgG1 protein produce antibodies specific for the BDC 2.5 cell-surface TCR. (A) T cells of the indicated type were stained by indirect immunofluorescence with (1) nonimmune NOD serum (line) or (2) anti-BDC 2.5 TCR-IgG1 antiserum (long broken line) followed by FITC goat anti-mouse Ig antibody. TCR expression was demonstrated by direct immunofluorescent staining with (3) FITC anti-V $\beta$ 4 mAb (short broken line) for BDC 2.5 and 6.9 cells, and (5) FITC anti-TCR C $\beta$  mAb for purified NOD splenic T cells (long-short broken line). (4) Isotype-matched controls were FITC-anti-V $\beta$ 6 for the V $\beta$ 4-specific mAb, and FITC anti-V $\gamma$ 3 for the TCR C $\beta$ -specific mAb (dotted line). (B) BDC 2.5 cells were preincubated (30 min on ice in presence of 0.1% sodium azide) with (6) buffer alone (line), (7) a 1:10 dilution of pooled NOD mouse

nonimmune serum (long broken line), or (8) a 1:10 dilution of NOD mouse anti-BDC 2.5 TCR-IgG1 antiserum (short broken line). The cells were then stained with FITC anti-V $\beta$ 4 mAb, or FITC anti-TCR C $\beta$  as indicated.

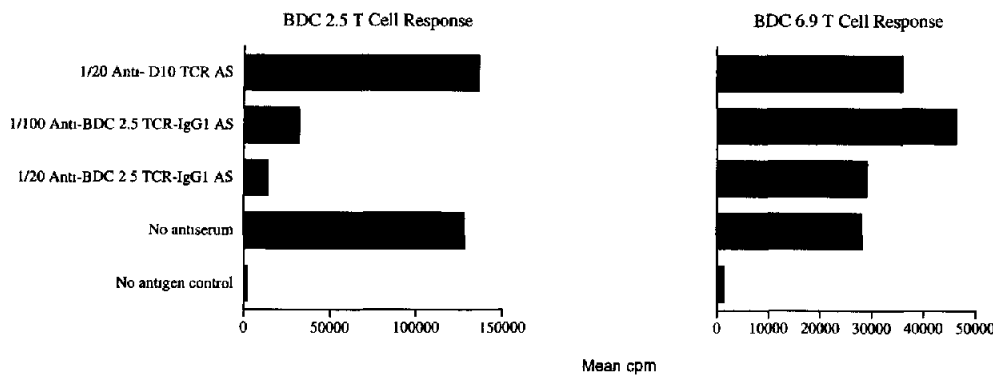
the supernatants of Sf9 cultures infected with either the v7/599 or the v3/598 recombinant baculovirus containing gene constructs encoding only the BDC 2.5 TCR  $\alpha$ -IgG1 or  $\beta$ -IgG1 chains (Fig. 4), whereas the supernatants of cultures simultaneously infected with both v7/599 and v3/598 contained heterodimeric material at a level of 500 ng/ml when the ratios of the v7/599:v3/598 MOI were 10:10 and 10:5. The ELISA could therefore be used with confidence to routinely monitor the amounts of heterodimeric BDC 2.5 TCR-IgG1 protein purified from the supernatants of large scale Sf9 and High 5 spinner cultures infected with the "double-promoter" recombinant baculovirus v20/599 encoding both the chimeric TCR  $\alpha$ -IgG1 and  $\beta$ -IgG1 constructs. In five batches, varying in volume from 3 to 7 liters, 0.5–1 mg/liter was routinely obtained after H57-immunoaffinity purification. This represented an overall yield of 12.5–25% since the unfractionated culture supernatants appeared to contain  $\sim$ 4 mg/liter as estimated by the ELISA.

**The Antibody Response to the BDC 2.5 TCR-IgG1 Chimeric Protein.** NOD mice were primed with the BDC 2.5 TCR-IgG1 protein in CFA. Boosting injections without adjuvant were given 14–21 d after priming and repeated after a further 14 d. All antisera collected 4 d after the second boosting were found to contain antibodies recognizing the soluble BDC 2.5 TCR-IgG1 protein by the ELISA, whereas indirect immunofluorescence revealed that 18 out of the 32 animals immunized made antibodies that bound the surface of the BDC 2.5 T cell clone (TCR: V $\alpha$ -1/V $\beta$ -4). Each of these 18 antisera appeared to be specific for the BDC 2.5 clone because BDC 6.9 cells (TCR: V $\alpha$ -13.1/V $\beta$ -4) were

not stained. The antisera reacting only in the ELISA were pooled, and the pool will be referred to as cell surface-staining negative (SS<sup>-</sup>). The 18 antisera that both reacted in the ELISA and stained the BDC 2.5 cells were also pooled to produce a cell surface-staining positive pool (SS<sup>+</sup>).

Analysis of the SS<sup>+</sup> pool indicated that the antibodies produced in response to BDC 2.5 TCR-IgG1 immunization and which recognized the BDC 2.5 cell surface were clonotype specific. The data are shown in Fig. 5 A. The antiserum pool stained BDC 2.5 T cells but not BDC 6.9 T cells or normal splenic NOD T cells, suggesting that the antibodies recognized clonotypic epitopes of the BDC 2.5 TCR. Detailed mapping of these epitopes in the variable region of the BDC 2.5 TCR was not possible due to the lack of mAb specific for this receptor; however, some association with the V $\beta$ -4 segment was indicated by the initial observation that individual mouse antisera could inhibit the binding of V $\beta$ -4 family-specific, FITC-labeled mAb to the BDC 2.5 cell surface. Data obtained with the SS<sup>+</sup> pool are shown in Fig. 5 B. BDC 2.5 cells were incubated with antiserum, nonimmunized NOD mouse serum, or buffer, washed, and stained with anti-V $\beta$ -4 or anti-C $\beta$  FITC-mAb. Pretreatment with the anti-BDC 2.5 TCR-IgG1 antiserum reproducibly inhibited staining with the anti-V $\beta$ -4 mAb in comparison with pretreatment with nonimmune serum. As expected, given the apparent clonotype specificity of the antiserum (Fig. 5 A), it did not interfere with the binding of the C $\beta$ -specific, H57 mAb any more strongly than nonimmune serum.

Antibodies recognizing TCR clonotypic epitopes are usually able to inhibit the antigen-specific responses of the



**Figure 6.** NOD mouse anti-BDC 2.5 TCR-IgG1 antiserum specifically blocks the antigen-specific response of the BDC 2.5 T cell clone in vitro. Rested BDC 2.5 or 6.9 T cells were preincubated (37°C for 1 h) with or without the indicated dilutions of antisera raised against BDC 2.5 TCR-IgG1 or D10 dcTCR proteins, and then tested for their response to NOD/RIP-Tag islet cells and NOD APC in the standard proliferation assay. The anti-D10 dcTCR antiserum used as a control was raised in

AKR mice, and contained antibodies specific for cell-surface clonotypic epitopes of the D10 T cell clone. Unstimulated control cultures received APC without islet cells. The values represent the mean [<sup>3</sup>H]thymidine incorporated during a 16-h pulse after a 72-h culture period.

appropriate T cell clone in vitro (47). Likewise, the SS<sup>+</sup> antiserum strongly inhibited the in vitro proliferative response of the BDC 2.5 cells to antigen, but had no effect on the response of the BDC 6.9 cell (Fig. 6). The responses of both the BDC 2.5 and BDC 6.9 T cell clones were stimulated by irradiated NOD mouse spleen cells as a source of APC, and NOD/LtRIP-Tag pancreatic islet cells as a source of antigen.

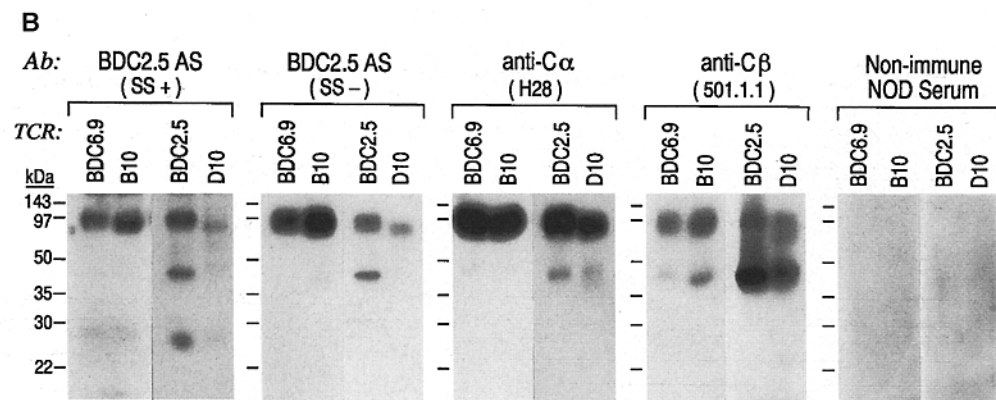
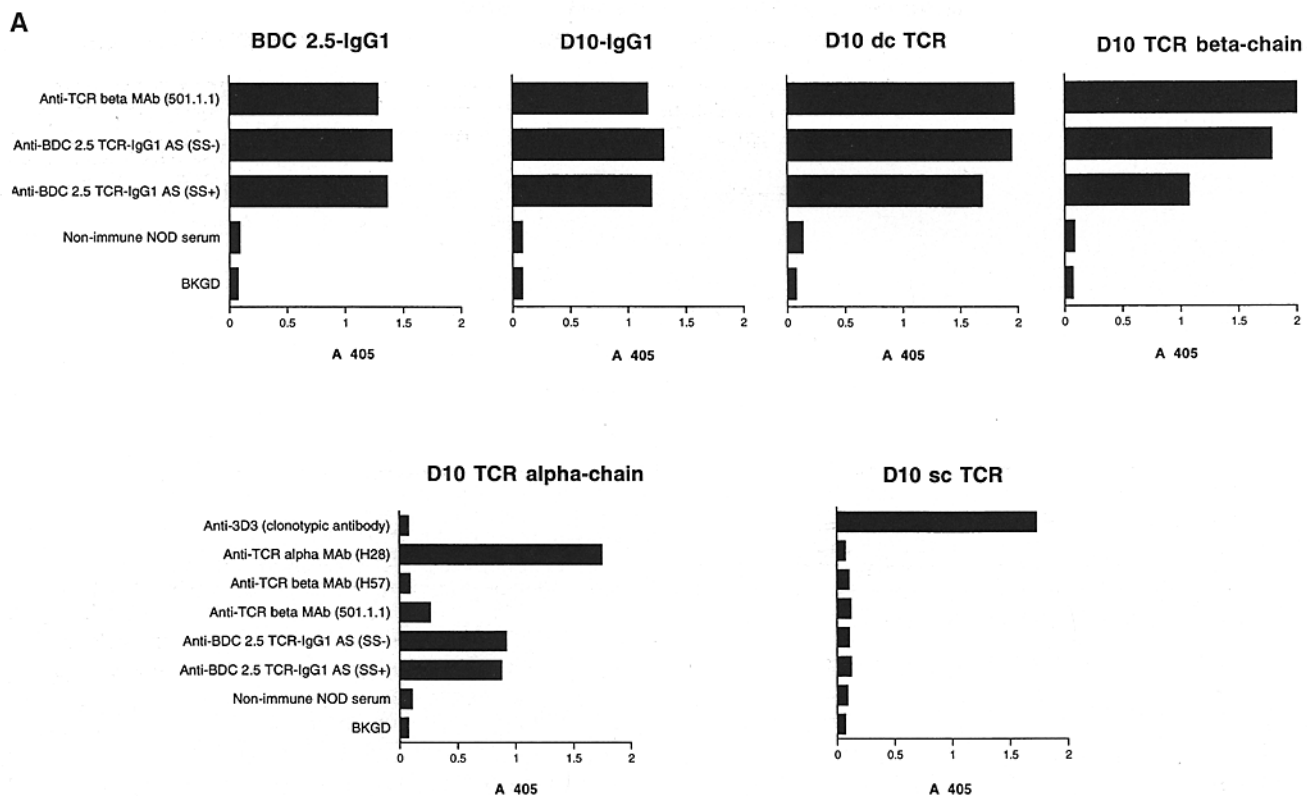
The TCR specificities of the SS<sup>-</sup> and SS<sup>+</sup> pools were compared by ELISA using different soluble TCR immobilized on the plates. Both SS<sup>-</sup> and SS<sup>+</sup> antisera bound to BDC 2.5 TCR-IgG1 and D10 TCR-IgG1 (TCR V $\alpha$ -2/V $\beta$ -8.2) proteins (Fig. 7 A); the latter receptor was derived from the hen egg conalbumin-specific and I-A<sup>k</sup>-restricted D10 T cell clone (26). The cross-reaction appeared to be due to antibodies specific for epitopes of the  $\alpha$ - and  $\beta$ -chains of the TCR rather than the IgG1 constant region domains of the chimeric protein because the antisera recognized the D10 dcTCR, and the D10 TCR individual  $\alpha$ - and  $\beta$ -chains (Fig. 7 A). These D10 TCR proteins were produced in soluble form by deletion of the transmembrane and cytoplasmic portions of the TCR without the addition of the CH2 and CH3 domains of IgG1. In each, the carboxyl terminus was formed by the amino acid immediately following the cysteine residue that participates in interchain disulfide bond formation. Both the SS<sup>+</sup> and SS<sup>-</sup> antisera failed to recognize the D10 single-chain (sc) TCR containing only the V $\alpha$  and V $\beta$  segments joined by a synthetic linker of 27 amino acids (Fig. 7 A). That the variable region of the D10 scTCR was intact was demonstrated by the ELISA data showing the presence of the conformational, clonotypic epitope recognized by the 3D3 mAb (Fig. 7 A). Both the V $\beta$ -8 and V $\alpha$ -2 family-specific epitopes were also present (data not shown). The absence of reactivity of the SS<sup>+</sup> and SS<sup>-</sup> antisera with the D10 scTCR therefore suggests that the cross-reactivity with the D10 dcTCR, and the  $\alpha$ -chain and  $\beta$ -chain proteins was due to antibodies specific for the TCR C $\alpha$  and C $\beta$  domains.

The question arose as to why the SS<sup>+</sup> antiserum was apparently specific for TCR clonotypic epitopes detected by

indirect immunofluorescent staining of the BDC 2.5 cell surface and yet broadly cross-reactive against different soluble TCR by the ELISA. There were two possible explanations. Either the constant region epitopes recognized in the soluble TCR were unavailable for antibody binding in the cell membrane-bound native BDC 2.5 TCR, or the soluble TCR expressed unique C $\alpha$  and C $\beta$  determinants formed by posttranslational modification, e.g., glycosylation, specific to the baculovirus-infected insect cell. To address these possibilities, TCR were immunoprecipitated by the anti-C $\beta$  mAb, H57, from NP-40 detergent extracts of BDC 2.5 (TCR V $\alpha$ -1/V $\beta$ -4), BDC 6.9 (TCR V $\alpha$ -13.1/V $\beta$ -4), B10 (TCR V $\alpha$ -11/V $\beta$ -16), and D10 (TCR V $\alpha$ -2/V $\beta$ -8.2) T cell clones, and analyzed by 10.5% SDS-PAGE under nonreducing conditions. Immunoblots were then performed with the same SS<sup>+</sup> and SS<sup>-</sup> antiserum pools previously analyzed by the ELISA. The reactivity of both antisera with material of ~90 kD (Fig. 7 B), regardless of the T cell source, indicated the presence of antibodies specific for linear, constant region epitopes of the T cell-synthesized TCR. Control mAb recognizing constant regions of TCR  $\alpha$ - (H28) and  $\beta$ - (501-1.1) chains reacted with material of identical size for each TCR. In addition, both the SS<sup>+</sup> and SS<sup>-</sup> antisera have been shown to immunoprecipitate TCR released by NP-40 detergent extraction of the BDC 2.5, BDC 6.9, D10 and B10 T cell clones (data not shown), indicating that denaturation of the TCR in SDS is not required for exposure of the constant region epitopes recognized by the antisera.

*Maternal Immunization with BDC 2.5 TCR-IgG1 Protects Young NOD Offspring from Diabetes Induced by the Adoptive Transfer of the BDC 2.5 T Cell Clone.* One group of 8–10-wk-old female NOD mice was immunized with BDC 2.5 TCR-IgG1 protein. A second group was similarly immunized with the D10 TCR-IgG1 protein, and a third group was not immunized. All the mice were mated with 8–10-wk-old male NOD mice. In the immunized groups, mating began on the day of the first boosting injection, and pregnant mice were further boosted by the intravenous injection of 20  $\mu$ g TCR-IgG1 between days 13 and 16 of





**Figure 7.** NOD mice immunized with the BDC 2.5 TCR-IgG1 protein produce antibodies specific for constant region epitopes exposed in soluble forms of the TCR. (A) The wells of 96-well plates were coated with the indicated recombinant, soluble TCR preparations: BDC 2.5 TCR-IgG1, D10 TCR-IgG1, D10 dcTCR, D10  $\beta$ -chain, D10  $\alpha$ -chain, and D10 scTCR. After incubation with the sera or antibodies indicated on the ordinate, antibody binding to the plated TCR was detected by alkaline phosphatase-coupled antibodies

specific for mouse Ig  $\kappa$  and  $\lambda$  light chains. TCR  $\alpha$ -chain (H28)- and  $\beta$ -chain (H57)-specific mAb, and the 3D3 mAb were biotinylated, and their binding was detected with alkaline phosphatase-coupled streptavidin. The ELISA show that NOD mouse anti-BDC 2.5 TCR-IgG1 SS<sup>-</sup> and SS<sup>+</sup> antisera reacted with epitopes shared by BDC 2.5 TCR-IgG1, D10 TCR-IgG1, D10 dcTCR and the D10 TCR  $\alpha$ - and  $\beta$ -chains, but not with D10 scTCR that lacked the TCR constant-regions. (B) Equivalent numbers of cells from each of the four T cell clones (BDC 6.9, B10, BDC 2.5, and D10) were lysed in NP-40, and the TCR were immunoprecipitated with anti-TCR C $\beta$ -specific mAb H57 as described in Materials and Methods. Protein was separated by SDS-PAGE under nonreducing conditions and immunoblotted with the indicated serum (1:200 dilution). H28 mAb was used at 4  $\mu$ g/ml, and 501.1.1 mAb was used as a hybridoma supernatant. Antibody reactivity was detected with either polyspecific goat anti-mouse Ig Ab conjugated to HRP or goat anti-hamster IgG-HRP at a 1:2,000 dilution as described in Materials and Methods.

gestation. Nursing mothers were given final boosts 14 d later. Sera were collected 4 d after the final boost, and indirect immunofluorescent cell surface staining (described earlier in Results) was used to determine which BDC 2.5 TCR-IgG1-immunized mothers had mounted a BDC 2.5 clonotype-specific response. All of the D10 TCR-IgG1 immunized mothers made antibodies specific for the cell surface clonotype of the D10 TCR as indicated by immunofluorescent staining of D10 cells but not B1 clone T cells

(also using TCR V $\beta$ -8 segment) or AKR mouse splenic T cells. The serological specificity of the immune response to soluble D10 TCR will be described in detail elsewhere.

At 10–21 d of age, pups born of the immunized NOD mothers and a group of nonimmunized mothers were injected (i.p.) once per week for 3 wk with  $5 \times 10^6$ – $10 \times 10^6$  viable T cells of either the BDC 2.5 or BDC 6.9 islet-specific clones. The onset of diabetes was monitored, and the data are presented in Table 1. As expected from previ-

**Table 1.** Effect of BDC 2.5 TCR-IgG1 Immunization of Female NOD Mice on the Incidence of Adoptively Transferred Diabetes in Their Offspring

Soluble TCR immunization of NOD mother	Maternal antibodies produced	Incidence of diabetes in offspring injected with the diabetogenic T cell clone	
		BDC 2.5	BCD 6.9
Nonimmunized	None	20/63 (32%)	7/16 (44%)
BDC 2.5 TCR-IgG1	BDC 2.5 clonotype-specific	0/21 (0%)	4/10 (40%)
BDC 2.5 TCR-IgG1	TCR constant region-specific—non-T cell surface reactive	17/29 (59%)	8/18 (44%)
D10 TCR-IgG1	D10 clonotype-specific	6/28 (21%)	Not tested

Female NOD mice were primed with TCR-IgG1 proteins in CFA and boosted without adjuvant 14–21 d later. On the day of boosting the mice were mated with male NOD mice. Pregnant mice were further boosted by intravenous of TCR-IgG1 between days 13 and 16 of gestation. Nursing mothers were given final boosts 14 d later. Nonimmunized mice received no TCR-IgG1 injections. Antibody specificity was determined by indirect immunofluorescence (as described above) with mothers' sera 4 d after the final boost. In BDC 2.5 TCR-IgG1 immunized mice that failed to make a BDC 2.5 clonotype-specific response, the production of antibodies to the TCR constant region was demonstrated by the ELISA described above. At 10–21 d of age the offspring were injected once per week for 3 wk with  $5 \times 10^6$ – $1 \times 10^7$  BDC 2.5 or BDC 6.9 T cells. Diabetes was monitored and diagnosed as described in Materials and Methods.

ously published data (19), both BDC 2.5 and BDC 6.9 T cells induced the early onset of diabetes. Disease occurred between 10 and 25 d after the first injection of cells in 30–50% of pups delivered by nonimmunized mothers, as opposed to the natural time of onset, which is usually at >3 mo of age in unmanipulated NOD mice. Immunizations of mothers that successfully resulted in a BDC 2.5 TCR clonotype-specific antibody response appeared to completely protect their pups from the induction of diabetes by the adoptive transfer of the BDC 2.5 T cell clone. In contrast, injection of the BDC 6.9 clone into pups from mothers producing BDC 2.5 TCR clonotype-specific antibodies resulted in accelerated diabetes with an incidence similar to that in control pups from nonimmunized mothers. As described above, the islet-specific BDC 6.9 T cell clone is clonotypically distinct from BDC 2.5; therefore the protection against adoptively transferred disease afforded by maternal immunization appeared to be immunologically specific. The immunological specificity of the maternally transferred protection was further demonstrated by the failure of immunization against the D10 clonotype to provide protection (Table 1). The BDC 2.5 TCR clonotype specificity of the maternally transferred protection strongly suggests that it was mediated via the transfer of specific antibodies from the mother, either transplacentally or in milk, or by both routes. This interpretation was supported by the demonstration that 3–4-wk-old offspring of mothers successfully immunized with TCR-IgG1 protein contained titers of clonotype-specific antibodies between 1/100 and >1/1000, as determined by indirect immunofluorescence.

## Discussion

Infection of insect cells with recombinant baculovirus has enabled the production of soluble BDC 2.5 TCR-IgG1

in the milligram amounts required for the immunization of mice. The recombinant protein was purified by C $\beta$ -specific H57 mAb-immunoaffinity chromatography. SDS-PAGE of purified material under nonreducing conditions revealed a major species with an apparent molecular mass of 110 kD, which is within the range predicted from the molecular sizes of the BDC TCR  $\alpha$ -IgG1 and  $\beta$ -IgG1 chains, and a larger species of  $\sim$ 200 kD. Since reduction of purified protein yielded a band migrating in the size range expected for the separate chimeric chains (50–55 kD), the larger non reduced species probably resulted from covalent aggregation due to mispaired disulfide bonds. Immunoprecipitation of approximately equal amounts of the purified protein with both the H57 mAb and the C $\alpha$ -specific H28 mAb, as judged by SDS-PAGE, indicated that the H57-immunoaffinity purification yielded material that was mainly composed of  $\alpha/\beta$  heterodimers. The heterodimeric nature of the purified protein was also supported by equivalent reactivity with both mAb in a BIAcore experiment. Analysis of the conformation and functional activity of BDC 2.5 TCR-IgG1 was not possible due to the lack of a BDC 2.5 clonotype-specific mAb, and the unknown nature of the peptide which, when complexed with I-A<sup>k</sup> MHC class II molecule of the NOD mouse, forms the antigen for the BDC 2.5 T cell clone. We have, however, used a similar technique to produce and purify a soluble version of the D10 TCR in milligram amounts. In BIAcore experiments this recombinant protein was shown to bind the 3D3 mAb, which recognizes a conformational D10 clonotypic epitope, the V $\beta$ -8 reactive SEC 2 superantigen, and the specific antigen complex of I-A<sup>k</sup> and conalbumin peptide (Khandekar et al., manuscript submitted for publication). Because immunization of NOD mice with the purified BDC 2.5 TCR-IgG1 stimulated the production of antibodies recognizing clonotypic epitopes of the BDC 2.5 cell surface

TCR, it would appear that similarly to the soluble D10 TCR, structural features of the variable regions of the native TCR are possessed by the BDC 2.5 TCR-IgG1 protein.

BDC 2.5 TCR-IgG1 immunization experiments provided evidence that when administered in a soluble form, a TCR can be immunogenic in mice of the strain from which it was derived. Immunization of NOD mice with the NOD-derived BDC 2.5 TCR-IgG1 protein stimulated antibody responses against both constant- and variable-region epitopes of the TCR. The production of antibodies that both recognized clonotypic epitopes of the native cell-surface TCR and inhibited antigen-specific activation of the BDC 2.5 T cell clone suggested that BDC 2.5 TCR-IgG1 immunizations might block the induction of diabetes by the adoptive transfer of the BDC 2.5 clone *in vivo*. Using the maternal transfer of BDC 2.5 TCR-specific antibodies we have indeed been able to demonstrate that soluble TCR immunization can bring about the clonal regulation of T cell function *in vivo*. There was a strong correlation between the production of TCR clonotype-specific antibodies in BDC 2.5 TCR-IgG1 immunized NOD mothers and the inhibition of diabetes induction by the BDC 2.5 T cell clone in their offspring.

NOD mice that were immunized with BDC 2.5 TCR-IgG1 consistently mounted antibody responses against TCR constant region epitopes. The NOD mouse anti-BDC 2.5 TCR-IgG1 antisera recognized antigens on baculovirus-produced soluble versions of the BDC 2.5 TCR, the D10 TCR, and the individual  $\alpha$ - and  $\beta$ -chains of the D10 TCR. The antisera did not react with these nonclonotypic antigens of TCR expressed *in situ* on the surface of T cell clones. It can be concluded that during immunization *in vivo*, the BDC 2.5 TCR-IgG1 protein presented TCR constant region antigens to the immune system that are not normally exposed on the T cell surface. Furthermore, the reaction of the antisera with the constant region antigens could be detected by immunoblotting of BDC 2.5, BDC 6.9, D10, and B10 TCR immunoprecipitated from the respective T cell clones, indicating that some of the antigens are linear epitopes. It is possible that these epitopes were exposed and immunogenic in the recombinant soluble BDC 2.5 TCR-IgG1 preparations due to errors in folding, or partial denaturation of the protein. However, the ability of the antisera to immunoprecipitate TCR from nonionic detergent extracts of different T cell clones suggests that native TCR constant region epitopes were recognized. The epitopes appear to be hidden in the TCR when it is present *in situ* as an integral membrane protein of the T cell, probably due to their close proximity to either the cell-surface membrane, or components of the CD3 complex. Because they are normally unavailable for immune recognition, the constant region antigens presumably escape B cell tolerance during development of the immune system *in vivo*.

In addition to antibodies to the cryptic constant region epitopes, 56% of BDC 2.5 TCR-IgG1 immunized NOD mice produced antibodies that strongly stained the BDC 2.5 cell surface by indirect immunofluorescence. The anti-

sera did not stain either the BDC 6.9 T cell clone or NOD mouse splenic T cells, and whereas they blocked the antigen-specific activation of BDC 2.5 cells *in vitro*, they did not interfere with the activation of BDC 6.9 cells by the same antigen. Among the BDC 2.5 TCR epitopes recognized by the antisera, some at least appeared to be close enough to the V $\beta$  segment to allow the antibodies to block, albeit to a relatively small extent, the binding of a V $\beta$ -4 family-specific mAb to the BDC 2.5 cell-surface receptor. The antisera did not contain antibodies recognizing V $\beta$ -4 family-specific epitopes, because they did not stain BDC 6.9 cells which also use the V $\beta$ -4 gene segment. The data suggest that the antisera recognized BDC 2.5 clonotypic determinants.

The serologic specificities of the antibody response in NOD mice immunized with the syngeneic BDC 2.5 TCR-IgG1 do not seem to be unique because we have observed very similar responses in AKR mice immunized with soluble D10 TCR (Jesson, M.I., U. McKeever, S. Khandekar, J. Newcomb, J. Naylor, P. Gregory, P. Brauer, B. Bettencourt, J. Banerji, and B. Jones, manuscript in preparation). The effect of the IgG1 portion on the immunogenicity of the chimeric receptor has not been formally evaluated in the NOD mouse. Preliminary data in AKR mice indicated that soluble D10 dcTCR produced in the baculovirus system without the IgG1 domains could also stimulate antibody responses. The responses were of similar potency and specificity to those mounted against the D10 TCR-IgG1 protein, and therefore the Fc portion of the TCR-IgG1 protein does not appear to increase the immunogenicity of the TCR appreciably.

The success of soluble TCR-IgG1 immunization in stimulating the production of antibodies recognizing native clonotypic epitopes of the BDC 2.5 TCR led us to perform an experiment designed to investigate the concept that TCR immunization *in vivo* can bring about the clonal regulation of autoimmune T cells. As explained in the introduction to this article, we had to adopt a strategy of maternal immunization in order to provide TCR-specific serum antibodies in the young (2-3-wk-old) NOD mice used as recipients of the diabetogenic T cells. The data indicate that when BDC 2.5 TCR-IgG1 immunization successfully stimulated a BDC 2.5 clonotype-specific antibody response in the NOD mothers, then the litters were protected from the induction of diabetes by the BDC 2.5 T cell clone. Protection appeared to be T cell clone specific because maternal immunization against the BDC 2.5 clonotype did not prevent the transfer of diabetes by the BDC 6.9 T cell clone. Immunological specificity was also supported by the failure of D10 TCR-IgG1 immunizations that stimulated a D10 TCR clonotype-specific antibody response in the NOD mothers to protect the offspring against diabetes induced by the BDC 2.5 T cell clone. As expected, BDC 2.5 TCR-IgG1 immunizations that only stimulated a response to non-cell-surface TCR constant region epitopes failed to afford protection in the litters.

The data demonstrate that using a relatively simple expression and purification strategy, it is possible to produce a

soluble TCR-IgG1 protein in which the TCR portion possesses clonotypic determinants that are immunogenic and cross-reactive with those found in the functionally active cell-surface form of the TCR. The ability of syngeneic immunizations with BDC 2.5 TCR-IgG1 to induce a humoral response that appeared to inhibit T cell-induced disease in a clone-specific fashion supports the concept that TCR vaccinations that stimulate humoral immunity can potentially modulate the course of a T cell mediated autoimmune disease. The challenge now is to design TCR vaccination strategies that can alter the course of spontaneous autoimmune disease. Although in the outbred human population it seems unlikely that autoimmune diseases will be generally triggered by T cell clones that share a clonotypic epitope, multiple sclerosis may prove to be an exception. Oksenberg and colleagues (48) have found common amino acid sequence motifs in the VDJ region of T cells using the V $\beta$ -5.2/3 gene segment in multiple sclerosis brain plaques. These VDJ sequences might represent immunogenic clonotypic epitopes that could be targeted by TCR vaccination. Recent experiments in an adoptive transfer model of mouse EAE with the encephalitogenic T cell clone L10C1 indicate that suppression of a single T cell clone can prevent disease (49). L10C1 recognizes the MBP epitope p87-99, and the CDR3 sequences in the TCR  $\alpha$ - and  $\beta$ -chains are homologous to those in rat clones specific for MBP p87-99 and human multiple sclerosis brain plaques. After injection of L10C1 cells into (PL/J  $\times$  SJL/J)F1 mice, treatment of the mice with an altered peptide ligand prevented EAE. The heterogeneous expression of TCR genes observed in the inflammatory infiltrates of EAE induced by L10C1 in untreated mice was dramatically reduced by administration of the altered peptide ligand after the onset of paralysis. Our data demonstrating the efficacy of TCR vaccination in the adoptive transfer model of mouse insulin-dependent diabetes mellitus suggest that vaccination against the CDR3 epitope(s) shared by L10C1 and human brain plaque sequences could prevent disease in a

similar fashion. Treatment with anti-TCR antibodies of appropriate specificity should also be effective, and in the human this would be a clinically acceptable approach.

While vaccination against TCR clonotypes will probably not be applicable to all autoimmune diseases, vaccination against particular TCR V-regions might be more feasible. Although the topic of TCR V-gene usage in autoimmunity is controversial (50), there are data to suggest that some human autoimmune diseases involve T cells that use a restricted repertoire of TCR V-region segments, for example, TCR V $\beta$ -3, 6, 14, 15, and 17 in rheumatoid arthritis (51-54), and TCR V $\beta$ -3 and 13.1 in the skin lesions of psoriasis (55). The progression of such diseases might be ameliorated by soluble TCR immunizations that stimulate an antibody response against the family specific epitopes of the particular V $\beta$  segments involved. Indeed, as mentioned in the introduction to this article, immunization against peptides derived from the TCR V $\beta$ -8.2 segment could sometimes prevent EAE in those strains of rat and mouse in which the encephalitogenic T cells use the V $\beta$ -8.2 gene predominantly. TCR peptide vaccination seems to prime T cells that regulate encephalitogenic T cell function via an ill-defined mechanism (7). In contrast, the mechanism of TCR-specific antibody-mediated immunoregulation is comparatively straightforward, and we have now designed strategies where soluble TCR immunizations can stimulate an antibody response that oligoclonally modulates T cells using V $\beta$ -genes belonging to a particular family. Mouse strains of the V $\beta^a$  haplotype have a genomic deletion of the V $\beta$  5, V $\beta$  8, V $\beta$  9, V $\beta$  11, V $\beta$  12, and V $\beta$  13 gene loci (56). Vaccination of these strains with a soluble TCR containing one of the missing V $\beta$  segments should induce the formation of antibodies against its family-specific epitopes (57). We are currently investigating the immunoregulatory activity of maternal immunization against a TCR V $\beta$ -family in F<sub>1</sub> offspring that inherit a functional complement of V $\beta$ -gene segments from a father of a nondeleted strain.

---

We thank our colleagues mentioned in the text for providing reagents; Dr. Ellis Reinherz for helpful advice and discussion; Annmarie Jurczak, Thao Duong, and Gina Stroh for excellent technical assistance; Stanley Erck for his enthusiastic support, and Dr. Donald Capra for his detailed review of the work.

Address correspondence to Una McKeever, Procept Inc., 840 Memorial Drive, Cambridge, MA 02138.

Received for publication 11 March 1996 and in revised form 26 June 1996.

## References

1. Davis, M.M., and P.J. Bjorkman. 1988. T-cell antigen receptor genes and T-cell recognition. *Nature (Lond.)* 334:395-402.
2. Vandenbark, A.A., G. Hashim, and H. Offner. 1989. Immunization with a synthetic T-cell receptor V-region peptide protects against experimental autoimmune encephalomyelitis. *Nature (Lond.)* 341:541-544.
3. Howell, M.D., S.T. Winters, T. Olee, H.C. Powell, D.J. Carlo, and S.W. Brostoff. 1989. Vaccination against experimental allergic encephalomyelitis with T cell receptor peptides. *Science (Wash. DC)* 246:668-670.
4. Kumar, V., R. Tabibiazar, H.M. Geysen, and E. Sercarz. 1995. Immunodominant framework region 3 peptide from TCR V $\beta$ 8.2 chain controls murine experimental autoimmune encephalomyelitis. *J. Immunol.* 154:1941-1950.

5. Kumar, V., and E.E. Sercarz. 1993. The involvement of T cell receptor peptide-specific regulatory CD4<sup>+</sup> T cells in recovery from antigen-induced autoimmune disease. *J. Exp. Med.* 178:909–916.
6. Gaur, A., R. Haspel, J.P. Mayer, and C.G. Fathman. 1993. Requirement for CD8<sup>+</sup> cells in T cell receptor induced clonal unresponsiveness. *Science (Wash. DC)*. 259:91–94.
7. Offner, H., G.A. Hashim, and A.A. Vandenbark. 1994. Immunity to T cell receptor peptides: theory and application. *Regulatory Peptides*. 51:77–90.
8. Offner, H., M. Vainiene, B. Celmk, A.D. Weinberg, A. Buenafe, and A.A. Vandenbark. 1994. Coculture of TCR peptide-specific T cells with basic protein-specific T cells inhibits proliferation, IL-3 mRNA, and transfer of experimental autoimmune encephalomyelitis. *J. Immunol.* 153:4988–4996.
9. Desquenne-Clark, L., T.R. Esch, L. Otvos, and E. Heber-Katz. 1991. T-cell receptor peptide immunization leads to enhanced and chronic experimental allergic encephalomyelitis. *Proc. Natl. Acad. Sci. USA.* 88:7219–7223.
10. Acha-Orbea, H., D.J. Mitchell, L. Timmerman, D.C. Wrath, G.S. Tausch, M.K. Waldor, S.S. Zamvil, H.O. McDevitt, and L. Steinman. 1988. Limited heterogeneity of T cell receptors from lymphocytes mediating autoimmune encephalomyelitis allows specific immune intervention. *Cell.* 54:263–273.
11. Hashim, G.A., A.A. Vandenbark, A.B. Galang, T. Diamanduros, E. Carvalho, J. Srinivasan, R. Jones, M. Vainiene, W.J. Morrison, and H. Offner. 1990. Antibodies specific for V $\beta$ 8 receptor peptide suppress experimental autoimmune encephalomyelitis. *J. Immunol.* 144:4621–4627.
12. MacNeil, D., E. Fraga, and B. Singh. 1993. Characterization of murine T cell responses to peptides of the variable region of self T cell receptor  $\beta$ -chains. *J. Immunol.* 151:4045–4054.
13. Lin, A.Y., B. Devaux, A. Green, C. Sagerstrom, J.R. Elliot, and M.M. Davis. 1990. Expression of T cell antigen receptor heterodimers in a lipid-linked form. *Science (Wash. DC)*. 249:677–679.
14. Gregoire, C., N. Reai, F. Schweisguth, A. Necker, G. Mazza, N. Auphan, A. Millward, A.-M. Schmitt-Verhulst, and B. Malissen. 1991. Engineered secreted T-cell receptor  $\alpha\beta$  heterodimers. *Proc. Natl. Acad. Sci. USA.* 88:8077–8081.
15. Novotny, J., R.K. Ganju, S.T. Smiley, R. Hussey, M.A. Luther, M.A. Recny, R.F. Siliciano, and E.L. Reinherz. 1991. A soluble, single-chain T-cell receptor fragment endowed with antigen-combining properties. *Proc. Natl. Acad. Sci. USA.* 88:8646–8650.
16. Hoo, W.F., M.J. Lacy, L.K. Denzin, E.W. Voss, K.D. Hardman, and D.M. Kranz. 1992. Characterization of a single-chain T-cell receptor expressed in *Escherichia coli*. *Proc. Natl. Acad. Sci. USA.* 89:4759–4763.
17. Haskins, K., M. Portas, B. Bradley, D. Wegmann, and K. Lafferty. 1988. T-lymphocyte clone specific for pancreatic islet antigen. *Diabetes.* 37:1444–1448.
18. Haskins, K., M. Portas, B. Bergman, K. Lafferty, and B. Bradley. 1989. Pancreatic islet-specific T-cell clones from non-obese diabetic mice. *Proc. Natl. Acad. Sci. USA.* 86:8000–8004.
19. Haskins, K., and M. McDuffie. 1990. Acceleration of diabetes in young NOD mice with a CD4<sup>+</sup> islet-specific T cell clone. *Science (Wash. DC)*. 249:1433–1436.
20. Eilat, D., G.E. Kikuchi, J.E. Coligan, and E.M. Shevach. 1992. Secretion of a soluble, chimeric  $\gamma\delta$  T-cell receptor-immunoglobulin heterodimer. *Proc. Natl. Acad. Sci. USA.* 89:6871–6875.
21. Kappler, J., J. White, H. Kozono, J. Clements, and P. Marrack. 1994. Binding of a soluble  $\alpha\beta$  T-cell receptor to superantigen/major histocompatibility complex ligands. *Proc. Natl. Acad. Sci. USA.* 91:8462–8466.
22. Chang, H.-C., Z.Z. Bao, Y. Yao, A.G.D. Tse, E.C. Goyarts, M. Madsen, E. Kawasaki, P. Brauer, J.C. Sacchetti, S.G. Nathenson, and E.L. Reinherz. 1994. A general method of facilitating heterodimeric pairing between two proteins: application to expression of  $\alpha$  and  $\beta$  T cell receptor extracellular segments. *Proc. Natl. Acad. Sci. USA.* 91:11408–11412.
23. Candéas, S., J. Katz, C. Benoist, D. Mathis, and K. Haskins. 1991. Islet-specific T-cell clones from nonobese diabetic mice express heterogeneous T-cell receptors. *Proc. Natl. Acad. Sci. USA.* 88:6167–6170.
24. Hamaguchi, K., H.R. Gaskin, and E. Leiter. 1991. NIT-1, a pancreatic  $\beta$ -cell line established from a transgenic NOD/Lt mouse. *Diabetes.* 40:842–849.
25. Hanahan, D. 1985. Heritable formation of pancreatic  $\beta$ -cell tumors in transgenic mice expressing recombinant insulin/simian virus 40 oncogenes. *Nature (Lond.)*. 315:115–122.
26. Kaye, J., S. Porcelli, J. Tite, B. Jones, and C.A. Janeway. 1983. Both a monoclonal antibody and antisera specific for determinants unique to individual cloned helper T cell lines can substitute for antigen and antigen-presenting cells in the activation of T cells. *J. Exp. Med.* 158:836–856.
27. Sorger, S.B., S.M. Hedrick, P.J. Fink, M.A. Bookman, and L.A. Matis. 1987. Generation of diversity in T cell receptor repertoire specific for pigeon cytochrome C. *J. Exp. Med.* 165:279–301.
28. Chomczynski, P., and N. Sacchi. 1987. Single-step method of RNA isolation by acid guanidinium thiocyanate-phenol-chloroform extraction. *Anal. Biochem.* 162:156–159.
29. Barth, R.K., B.S. Kim, N.C. Lan, T. Hunkapiller, N. Sobieck, A. Winoto, H. Gershenfeld, C. Okada, D. Hansburg, I.L. Weissman, and L. Hood. 1985. The murine T-cell receptor uses a limited repertoire of expressed V $\beta$  gene segments. *Nature (Lond.)*. 316:517–523.
30. Kabat, E.A., T.T. Wu, M. Reid-Miller, H.M. Perry, and K.S. Gottesman. 1987. Sequences of Proteins of Immunological Interest. U.S. Department of Health and Human Services, Bethesda, MD. 530–548.
31. French, D.L., R.R. Pollock, H.L. Aguila, and M.D. Scharff. 1991. The molecular and biochemical characterization of mutant monoclonal antibodies with increased antigen binding. *J. Immunol.* 146:2010–2016.
32. Sambrook, J., E.H. Fritsch, and T. Maniatis. 1989. Molecular Cloning: A Laboratory Manual. Cold Spring Harbor Laboratory, Cold Spring Harbor, NY. 5.33–5.90.
33. Page, M.J., and B.C. Rodgers. 1995. Selection of recombinant baculoviruses by visual screening. In *Baculovirus Expression Protocols*. C.D. Richardson, editor. Humana Press, Totowa, NJ. 102–127.
34. Becker, M.L.B., R. Near, M. Mudgett-Hunter, M.N. Margolis, R.T. Kubo, J. Kaye, and S.M. Hedrick. 1989. Expression of a hybrid immunoglobulin-T cell receptor protein in transgenic mice. *Cell.* 58:911–921.
35. Kubo, R.T., W. Born, J.W. Kappler, P. Marrack, and M. Pigeon. 1989. Characterization of a monoclonal antibody which detects all murine  $\alpha\beta$  T cell receptors. *J. Immunol.* 142:2736–2742.
36. Harlow, E., and D. Lane. 1988. Monoclonal antibodies. In

- Antibodies: A Laboratory Manual. Cold Spring Harbor Laboratory, Cold Spring Harbor, New York. 139–243.
37. Harlow, E., and D. Lane. 1988. Immunoaffinity purification. *In* *Antibodies: A Laboratory Manual*. Cold Spring Harbor Laboratory, Cold Spring Harbor, New York. 511–552.
  38. Bradford, M.M. 1976. A rapid and sensitive method for the quantitation of microgram quantities of protein utilizing the protein-dye binding. *Anal. Biochem.* 72:248–254.
  39. Harlow, E., and D. Lane. 1988. Immunoprecipitation. *In* *Antibodies: A Laboratory Manual*. Cold Spring Harbor Laboratory, Cold Spring Harbor, New York. 421 pp.
  40. Laemmli, U.K. 1970. Cleavage of structural proteins during the assembly of the head of bacteriophage T4. *Nature (Lond.)*. 227:680–682.
  41. Johnsson, B., S. Lofas, and G. Lindquist. 1991. Immobilization of proteins to a carboxymethyl-dextran-modified gold surface for biospecific interaction analysis in surface plasmon resonance sensors. *Anal. Biochem.* 198:268–277.
  42. Harlow, E., and D. Lane. 1988. Immunoassay. *In* *Antibodies: A Laboratory Manual*. Cold Spring Harbor Laboratory, Cold Spring Harbor, New York. 553 pp.
  43. Bergman, B., and K. Haskins. 1994. Islet-specific T-cell clones from the NOD mouse respond to  $\beta$ -granule antigen. *Diabetes*. 43:197–203.
  44. Kuroda, K., H. Geyer, R. Geyer, W. Doerfler, and H.-D. Klenk. 1990. The oligosaccharides of influenza virus hemagglutinin expressed in insect cells by a baculovirus vector. *Virology*. 174:418–429.
  45. Aced, P.A., and A.P. Elhammer. 1994. Glycosylation of recombinant protein in insect cells: the insect cell line Sf9 does not express the mannose 6-phosphate recognition signal. *Biochemistry*. 33:8793–8797.
  46. Davidson, D.J., R.K. Bretthauer, and F.J. Castellino. 1991.  $\alpha$ -mannosidase-catalyzed trimming of high-mannose glycans in noninfected and baculovirus infected *Spodoptera frugiperda* cells (IPLB-SF-21AE). A possible contributing regulatory mechanism for assembly of complex-type oligosaccharides in infected cells. *Biochemistry*. 30:9811–9815.
  47. White, J., K.M. Haskins, P. Marrack, and J. Kappler. 1983. Use of I region-restricted, antigen-specific T cell hybridomas to produce idiotypically specific anti-receptor antibodies. *J. Immunol.* 130:1033–1037.
  48. Oksenberg, J.R., M.A. Panzara, A.B. Begovich, D. Mitchell, H.A. Erlich, M. Sherritt, J. Rothbard, C.C.A. Bernard, and L. Steinman. 1993. Selection for T-cell receptor V $\beta$ -Db-J $\beta$  gene rearrangements with specificity for a myelin basic protein peptide in brain lesion of multiple sclerosis. *Nature (Lond.)*. 362:68–70.
  49. Brocke, S., K. Gijbels, M. Allegretta, I. Ferber, C. Piercy, T. Blankenstein, R. Martin, U. Utz, N. Karin, D. Mitchell, et al. 1996. Treatment of experimental encephalomyelitis with a peptide analogue of myelin basic protein. *Nature (Lond.)*. 379:343–346.
  50. Gold, D.P. 1994. TCR V gene usage in autoimmunity. *Curr. Opin. Immunol.* 6:907–912.
  51. Paliard, X., S.G. West, J.A. Lafferty, J.R. Clements, P. Marrack, and B.L. Kotzin. 1991. Evidence for the effects of a superantigen in rheumatoid arthritis. *Science (Wash. DC)*. 253:325–329.
  52. Howell, M.D., J.P. Diveley, K.A. Lundeen, A. Esty, S.T. Winters, D.J. Carlo, and S.W. Brostoff. 1991. Limited T-cell receptor  $\beta$ -chain heterogeneity among interleukin-2 receptor-positive synovial T cells suggests a role for superantigen in rheumatoid arthritis. *Proc. Natl. Acad. Sci. USA*. 88:10921–10925.
  53. Grom, A., S.D. Thompson, L. Luyrink, M. Passo, E. Choi, and D.N. Glass. 1993. Dominant T cell receptor b chain variable region V $\beta$ 14<sup>+</sup> clones in juvenile rheumatoid arthritis. *Proc. Natl. Acad. Sci. USA*. 90:11104–11108.
  54. Jenkins, R.N., A. Nikaem, A. Zimmerman, K. Meek, and P.E. Lipsky. 1993. T cell receptor V $\beta$  gene bias in rheumatoid arthritis. *J. Clin. Invest.* 92:2688–2701.
  55. Chang, J.C.C., L.R. Smith, K.J. Froming, B.J. Schwabe, J.A. Laxer, L.L. Caralli, H.H. Kurland, M.A. Karasek, D.I. Wilkinson, D.J. Carlo, and S.W. Brostoff. 1994. T cells in psoriatic lesions preferentially use T cell receptors V $\beta$ 3 and/or V $\beta$ 13.1 genes. *Proc. Natl. Acad. Sci. USA*. 91:9282–9286.
  56. Behlke, M.A., H.S. Chou, K. Huppi, and D.Y. Loh. 1986. Murine T-cell receptor mutants with deletions of  $\beta$ -chain variable region genes. *Proc. Natl. Acad. Sci. USA*. 83:767–771.
  57. Kappler, J.W., T. Wada, J. White, E. Kushnir, M. Blackman, J. Bill, N. Roehm, and P. Marrack. 1987. T cell receptor V $\beta$  segment that imparts reactivity to a class II major histocompatibility complex product. *Cell*. 49:263–271.