



Published in final edited form as:

Nature. 2010 September 9; 467(7312): 211–213. doi:10.1038/nature09368.

Production of *p53* gene knockout rats by homologous recombination in embryonic stem cells

Chang Tong¹, Ping Li^{1,†}, Nancy L. Wu², Youzhen Yan², and Qi-Long Ying¹

¹ Eli and Edythe Broad Center for Regenerative Medicine and Stem Cell Research at USC, Department of Cell & Neurobiology, Keck School of Medicine, University of Southern California, Los Angeles, CA 90033, USA

² USC/Norris Cancer Center Transgenic/Knockout Core Facility, Keck School of Medicine, University of Southern California, Los Angeles, CA 90033, USA

Abstract

The use of homologous recombination to modify genes in embryonic stem (ES) cells provides a powerful means to elucidate gene function and create disease models¹. Application of this technology to engineer genes in rats has previously been impossible in the absence of germline competent ES cells in this species. We have recently established authentic rat ES cells^{2, 3}. Here we report the generation of the first gene knockout rats using the ES cell-based gene targeting technology. We designed a targeting vector to disrupt the tumor suppressor gene *p53* (also known as *Tp53*) in rat ES cells *via* homologous recombination. *p53* gene-targeted rat ES cells can be routinely generated. Furthermore, the *p53* gene-targeted mutation in the rat ES cell genome can transmit through the germline *via* ES cell-rat chimeras to create *p53* gene knockout rats. The rat is the most widely used animal model other than humans in biological research^{4–7}. The establishment of gene targeting technology in rat ES cells, in combination with advances in genomics and the vast amount of research data on physiology and pharmacology in this species, now provides a powerful new platform for the study of human disease.

In the past two decades, gene targeting in mouse ES cells has been used as a unique and powerful tool for elucidating gene function and addressing fundamental biological questions in mammals¹. This ES cell-based gene targeting technology allows us to create precise and conditional gene replacements (knock-in) or loss of function mutations (knockout) of the chosen locus. So far, this technology is only available for the mouse because of the inability to establish germline competent ES cell lines from other species. The rat is a more widely used model for studying human normal and disease processes and for testing drug efficacy

Users may view, print, copy, download and text and data- mine the content in such documents, for the purposes of academic research, subject always to the full Conditions of use: http://www.nature.com/authors/editorial_policies/license.html#terms

Correspondence and requests for materials should be addressed to Q.L.Y. (qying@usc.edu).

[†]Present address: Key Laboratory of Molecular Medicine, Ministry of Education, Fudan University, Shanghai 200032, China

Author Contributions C.T. designed and performed most of the experiments described in the paper. P.L. and Q.L.Y. derived and cultured rat ES cells. N.L.W. and Y.Y. performed blastocyst injections. Q.L.Y. conceived the study and wrote the paper.

Author Information The *p53* gene-targeted rats generated in this study will be deposited in the Rat Resource and Research Center at University of Missouri. Q.L.Y. is an inventor on a patent relating to this study filed by the University of Edinburgh and licensed to StemCells Inc.

and toxicity prior to human clinical trials⁴⁻⁷. Although several technologies have been used to genetically alter rats⁸⁻¹⁴, our ability to manipulate the rat genome and create rat disease models is greatly limited without the ES cell-based gene targeting technology. Recently, we developed the 3i/2i culture system that enabled the derivation of germline competent rat ES cells for the first time^{2, 3, 15}. To investigate whether the ES cell-based gene targeting technology developed for the mouse can be generally applied to the rat, we targeted the *p53* gene in rat ES cells.

p53 is a tumor suppressor and mutations in the *p53* gene are the most frequently observed genetic lesions in human cancers¹⁶. The rat *p53* gene locus on Chromosome 10 consists of 10 exons with the translation start codon located within exon 2 (Fig. 1a). We designed a targeting vector to disrupt the *p53* gene *via* homologous recombination in rat ES cells (Fig. 1a). The vector contained 6.7kb 5' and 1.6kb 3' homology arms which were amplified from Dark Agouti (DA) rat ES cell genomic DNA. Positive selection was provided by a CAG-EGFP-IRES-Pac cassette and negative selection by a phosphoglycerate kinase1-diphtheria toxin-A chain (PGK-DTA) selection cassette. Correctly targeted rat ES cells expressed puromycin N-acetyl transferase (Pac) and green fluorescent protein (GFP). The PGK-DTA cassette was placed at the end of 3' homology arm and was not incorporated into the chromosomes when homologous recombination occurred. Random integration of PGK-DTA was expected to reduce the number of puromycin resistant ES cell clones with random targeting vector integrations, enabling the enrichment of correctly targeted cells¹⁷.

In the targeted cells, CAG-EGFP-IRES-Pac replaced exons 2-5 of *p53* (Fig. 1b), resulting in a loss of function mutation (*p53^{tm1(EGFP-pac)}*). PCR primers were used to screen puromycin resistant rat ES cells for homologous recombination with the 3' arm of homology. The 5' PCR primer (tgcggtgggctctatggcttct) was located in the *Pac* gene. The 3' PCR primer (cggacatggacatctggtgga) was located between exon 8 and exon 9. The size of the expected PCR product in correctly targeted cells was 2140bp. We also designed 5', 3' and internal hybridization probes for the further confirmation of rat *p53* gene targeting by Southern blot (Fig. 1a, b).

To test whether the rat *p53* gene could be disrupted *via* homologous recombination, we introduced the *p53* gene targeting vector into DA rat ES cells by electroporation. Puromycin was added to the culture medium to select for transfected cells. We picked and expanded puromycin-resistant colonies and identified correctly targeted cells by PCR and Southern blot analysis. We transfected two male DA rat ES cell lines: DAc8 and DAc4 with the *p53* vector. As summarized in Supplementary Table 1, we obtained fourteen *p53* gene-targeted DA rat ES cell clones. Targeting efficiencies in DAc8 and DAc4 ES cells were 1.12% and 3.70%, respectively. Detailed PCR and Southern blot screening results are provided in Supplementary Fig. 1 and 2.

One *p53* gene-targeted rat ES cell clone, DAc8-p53-#1, was used to examine transmission of the *p53^{tm1(EGFP-pac)}* through the rat germline. DAc8-p53-#1 rat ES cells were GFP positive as expected (Fig. 2a). The correct targeting event in the DAc8-p53-#1 cells was also verified by Southern blot analysis using 5', 3' and internal probes (Fig. 2b). To further confirm that one of the *p53* alleles was disrupted in DAc8-p53-#1 rat ES cells, we designed PCR primers

to amplify and sequence the genomic DNA flanking the *p53* gene targeted region (Fig. 2c). The results showed that the *p53* targeting vector replaced the endogenous *p53* locus via homologous recombination (Fig. 2d-g). DAc8-p53-#1 ES cell-rat chimeras were prepared by microinjecting the cells into 79 blastocysts collected from E4.5 Fischer 344 (F344) rats. Microinjected blastocysts were transferred to pseudo-pregnant female Sprague Dawley (SD) rats. 24 live-born pups were produced, among which 10 male and 6 female pups were pigmented, indicating contributions from the DAc8-p53-#1 ES cells (Supplementary Fig. 3). The 10 male chimeras were mated with SD female rats to test for germline transmission of the targeted *p53* allele. All 10 male chimeras were fertile and produced over 600 offspring, among which one carried the DA rat ES cell genome as identified by the appearance of agouti coat color (Supplementary Fig. 4a). However, PCR genotyping result showed that this germline animal did not inherit the gene-targeted *p53* allele (Supplementary Fig. 4b, c).

Failure of mouse ES cells to contribute to the germline is often caused by chromosomal abnormalities in ES cells¹⁸. This is also likely to be true for rat ES cells. We examined the karyotype of DAc8-p53-#1 rat ES cells and found that over 65 percent of the cells were polyploid (Supplementary Fig. 5a). This is likely the reason for its low germline transmission efficiency. From mouse ES cell studies, it has been suggested that chromosomal abnormalities are associated with a selective growth advantage, and that the use of small, slower growing clones rather than large, rapidly growing clones for blastocyst injection will significantly improve the germline transmission rate¹⁸. We investigated whether germline competency of DAc8-p53-#1 rat ES cells could be improved through subcloning. DAc8-p53-#1 rat ES cells were plated at a clonal density as has been reported for mouse ES cells^{19, 20}. Around 10% of the cells formed round and compact colonies (Supplementary Fig. 5b). These colonies were picked and expanded to establish subclones. We karyotyped 20 DAc8-p53-#1 rat ES cell subclones and identified 2 subclones with euploid chromosome numbers (Supplementary Fig. 5c). The subclones grew as round and compact colonies (Supplementary Fig. 5d). The subclones were microinjected into a total of 39 F344 rat blastocysts. 2 male chimeras were produced and 1 was a germline chimera (Fig. 3a). This germline chimera generated 76 offspring among which were 6 germline pups. 3 of the germline pups, 1 male and 2 female, were GFP positive, indicating the inheritance of the *p53^{tm1(EGFP-pac)}* allele (Fig. 3b). Genotyping and Southern blot analysis further confirmed that these 3 pups were *p53* heterozygote animals carrying one wild-type and one targeted *p53* alleles (Fig. 3c, d).

To generate *p53* homozygous (knockout) rats, we intercrossed the three *p53* heterozygote rats. 12 pups were produced and 9 were GFP-positive (Fig. 4a). Genotyping analysis revealed that among the 9 GFP-positive pups, 7 were heterozygous and 2 were homozygous for the *p53^{tm1(EGFP-pac)}* allele (Fig. 4b). Northern and Western blot analyses further confirmed the absence of *p53* mRNA and p53 protein in the *p53* homozygote pup (Fig. 4c, d).

We have demonstrated that gene targeting *via* homologous recombination can be achieved in authentic pluripotent rat ES cells. Most importantly, the gene-targeted mutation in rat ES cells can transmit through the germline to produce gene knockout rats. The availability of ES cell-based gene targeting technology in the rat enables us to produce sophisticated and

precise genetic modifications, such as subtle mutations, gene replacements and chromosome rearrangements²¹. More importantly, by combining the Cre/loxP and inducible gene expression systems^{22–24}, we can introduce temporal control and tissue specific changes in genes in rat models *via* ES cell-mediated genetic modifications. Due to the wide use of rats in physiological and pharmacological studies, we anticipate that many of the rat models generated using ES cell-mediated gene targeting will provide a powerful platform for the study of human health and disease.

METHODS SUMMARY

***p53* gene targeting in rat ES cells**

Rat ES cells were routinely maintained in 2i conditions as described^{2, 3}. The rat *p53* gene targeting vector was constructed by insertions of 6.7kb 5' and 1.6kb 3' homology arms into the pCAG-EGFP-IRES-Pac plasmid. The rat *p53* gene targeting vector was introduced into DA rat ES cells by electroporation. After electroporation, 0.5µg/ml puromycin was added to select for transfected cells. The emerging puromycin-resistant colonies were picked and expanded. *p53* gene-targeted rat ES cell clones were identified by PCR screening and Southern blot analysis.

Generation of *p53* gene knockout rats

p53 gene-targeted DA rat ES cells were injected into blastocysts collected from E4.5 timed-pregnant F344 rats as described for mouse ES cell injections²⁵. ES cell-injected blastocysts were transferred to E3.5 pseudo-pregnant SD rats. Contribution of the injected *p53* gene-targeted DA rat ES cells in the resulting chimeras was identified by the appearance of agouti coat color. Male chimeras were bred with SD female rats to produce offspring carrying the *p53* gene-targeted mutation. *p53* heterozygote rats were intercrossed to produce *p53* knockout rats. Animal experiments were performed according to the investigator's protocols approved by the USC Institutional Animal Care and Use Committee (IACUC).

METHODS

Mice and Rats

CF-1 (Charles River Laboratory Stain Code 023) and Tg(DR4)1Jae/J (Jackson Laboratory Stock number 003208) (DR-4) strains of mice were used to prepare mouse embryonic fibroblasts (MEFs). MEFs prepared from the DR-4 mouse strain are resistant to G418, 6-thioguanine, puromycin and hygromycin. E4.5 timed-pregnant Fischer 344 inbred rats (F344/NHsd) and E3.5 pseudo-pregnant SD outbred rats (Hsd:Sprague Dawley SD) were purchased from Harlan Laboratories. Animal experiments were performed according to the investigator's protocols approved by the USC Institutional Animal Care and Use Committee (IACUC).

Rat ES cell culture

Rat ES cells were cultured at 37°C in a humidified 5% CO₂ incubator. They were routinely maintained on mitotically-inactivated CF-1 MEFs with N2B27 medium supplemented with 3µM CHIR99021 and 1µM PD0325901 (2i medium)^{2, 3, 15}. Rat ES cells attach loosely to

the feeders, so it is very easy to detach rat ES cells from the feeders by mechanical pipetting. Rat ES cells were passaged every 2–3 days. For passaging, rat ES cells were detached from feeders by pipetting and harvested by centrifugation. 0.025% trypsin/EDTA was added to the cell pellet to prepare a single cell suspension. 0.025% trypsin/EDTA solution was prepared by adding 5 ml of 2.5% trypsin (Invitrogen), 5 ml of chicken serum (Sigma) and 0.5 ml of 0.5 M EDTA (Invitrogen) to 500 ml sterile PBS. After trypsinization, GMEM/10% FCS medium was added to neutralize the trypsin. The cells were collected by centrifugation and resuspended in 2i medium. Rat ES cells were plated at a density of 8×10^4 cells/cm² so that they reached 60–80% confluency after 2–3 days in culture.

Construction of rat *p53* gene targeting vector

Gene targeting vectors must contain a drug-selectable marker in order to select recombinants. The selection marker gene is most commonly controlled by the PGK promoter in most mouse gene targeting vectors²⁶. Initially, we constructed the rat *p53* gene targeting vector using the PGK promoter to drive the expression of the EGFP-IRES-Pac selection cassette. Less than 20 puromycin-resistance colonies grew up after the electroporation of 100µg of the *p53* gene targeting vector into 7×10^6 rat ES cells. Rat ES cells are very sensitive to drug selection and we reasoned that low PGK promoter activity in rat ES cells might prevent the isolation of drug-resistance colonies. The CMV early enhancer/chicken β actin (CAG) promoter has been shown to drive high level gene expression in both mouse and rat ES cells^{3, 27, 28}. We compared the activity of PGK and CAG promoters in rat ES cells using the Dual-Luciferase Reporter Assay (Promega). The activity of the CAG promoter was 36 times higher than that of the PGK promoter. We then constructed a *p53* gene targeting vector using the CAG promoter to drive the expression of the EGFP-IRES-Pac selection cassette. The pCAG-EGFP-IRES-Pac plasmid was used as the backbone for the construction of rat *p53* gene targeting vector. The 5' and 3' homology arms were amplified from DA rat genomic DNA using Expand High Fidelity PCR System (Roche). The following primer pairs were used to amplify the homology arms: 5'-gtc gac aga agt tct cgg agc ggg tgc tga act-3', 5'-atc ctc cat gac agt tat ctg ca-3' (for 5' homology arm); 5'-tag gat cca caa agt cac aga gcc act ttc a-3', 5'-tag gat ccc ctc tga ctt att ctt get ct tag-3' (for 3' homology arm). PCR products were subcloned into the TOPO® vector (Invitrogen) and confirmed by DNA nucleotide sequencing. To construct the rat *p53* gene targeting vector, the 6.7 kb 5' homology arm was first inserted into the *SalI* site of the pCAG-EGFP-IRES-Pac plasmid, following by the insertion of the 1.6 kb 3' homology arm into the *BamHI* site. Finally, the PGK-DTA-polyA negative selection cassette was inserted at the end of the 3' homology arm.

Introducing the *p53* gene targeting vector into rat ES cells by electroporation

The passage numbers of DAc8 and DAc4 rat ES cell lines used for performing *p53* gene targeting were 32 and 14, respectively. The majority of rat ES cells attach loosely to feeders and grow as round and compact colonies, while few rat ES cells form flat and adherent colonies. We pre-selected adherent DAc8 rat ES cells and kept expanding them as adherent culture. It took over 15 passages to generate a high proportion of adherent DAc8 rat ES cells in culture and this was the reason why we used the high passage number of DAc8 rat ES cells for the first *p53* gene targeting experiment. Now we found that rat ES cells grown as

adherent cells in culture are mostly karyotypically abnormal. DAc8 and DAc4 rat ES cells remain euploid after 35–40 passages if they are passaged using the method described in the “Rat ES cell culture” section. Rat ES cells were dissociated into single cells using 0.025% trypsin/EDTA and trypsin was neutralized with GMEM/10%FCS medium. After washing twice with PBS, 7×10^6 Rat ES cells were mixed with 100 μ g of linearized *p53* gene targeting vector in 0.8 ml PBS and transferred to a 4 mm-gap Gene Pulser Cuvette (Bio-Rad). The cuvette was placed in the electroporation holder of the Bio-Rad Gene Pulser XCell™ (Bio-Rad) and electroporated at 200V, 500 μ F. After electroporation, the cells were plated into three 100-mm tissue culture dishes pre-seeded with mitotically-inactivated DR-4 MEFs and cultured in 2i medium. Rat ES cells are very sensitive to drug selection compared to mouse ES cells. The following drug selection scheme was applied: First, one day after electroporation, puromycin was added to the medium at 0.5 μ g/ml. The cells were incubated in the presence of puromycin for 2 days. Following this incubation, the puromycin was removed and fresh rat ES cell culture medium was added. The cells were then incubated in the absence of puromycin for one day. This process represents one “cycle” in the selection strategy. Selection was completed after 3 consecutive cycles. The emerging puromycin-resistant colonies were picked and expanded.

PCR screening for rat *p53* homologous recombination

Puromycin-resistant colonies were expanded and split into two duplicate 96-well plates, one of which was used for PCR screening while the other remained in culture. Genomic DNA was extracted from each clone using ZR-96 Quick-gDNA kit (Zymo research) and eluted in 30 μ l of distilled water. The PCR primer pair for screening correctly targeted cells was described in the main text. PCR reactions were performed using the following cycle conditions: 95°C for 2 min to denature the DNA, then 95°C for 20 sec, 60°C for 20 sec and 72°C for 1 min, for 40 cycles. PCR amplification products were separated on 1% agarose gels. The expected size fragment from correctly targeted *p53* cells was 2140bp.

Subcloning and karyotyping

For subcloning, 1×10^4 DAc8-p53-#1 rat ES cells were plated onto a 100-mm dish pre-seeded with CF-1 MEFs and cultured in 2i medium. The culture medium was changed every other day. 8 days after plating, colonies with a round and compact morphology were picked and each colony was placed into a drop of 10 μ l 0.025% trypsin/EDTA. After incubation at room temperature for 3–5 min, the colonies were dissociated into single cells by pipetting and directly transferred to a 96-well plate pre-seeded with CF-1 MEFs and cultured in 2i medium supplemented with 1%FCS (addition of 1%FCS is necessary to neutralize trypsin). The next day, FCS/trypsin containing 2i medium was carefully removed and fresh 2i medium was added. The cells were then passaged and expanded as described above. For karyotyping, rat ES cells were plated onto 6-well plates at a density of 1×10^6 cells/well. One day after plating, 100ng/ml colcemid (Sigma) was added to the culture which was incubated for 2 hours. The rat ES cells were then harvested for metaphase preparation by standard methods²⁵.

Blastocyst injection

Blastocysts were collected from E4.5 timed-pregnant F344 rats. After washing through several drops of M2 medium (Sigma), blastocysts were transferred to an oil overlaid microdrop of M16 medium (Sigma) in a 35-mm plastic tissue culture dish and incubated for 2–4 hours at 37°C in a humidified 5% CO₂ incubator to allow the expansion of the blastocoel cavity. 12–15 *p53* gene-targeted rat ES cells were injected into each well-expanded blastocyst using the same technique as described for mouse ES cell injections²⁵. ES cell-injected blastocysts were transferred to E3.5 pseudo-pregnant SD rats as follows. First, pseudo-pregnant rats were anesthetized by intraperitoneal injection of 50mg/kg ketamine (Bioniche Pharma USA) and 10mg/kg xylazine (Akorn, Inc). The uterus was exteriorized and a hole was made in the uterus with a 27 gauge needle a few millimeters down from the utero-tubal junction. 8–10 ES cell-injected blastocysts were transferred into the uterus with a mouth-controlled embryo transfer pipette. At the end of procedure, the rat was placed in a clean cage and kept warm until it recovered from anesthesia. Pups were normally born 18–19 days after the transfer of blastocysts. Contribution of the *p53* gene-targeted rat ES cells to the resulting chimeras was identified by the appearance of agouti coat color. Male chimeras were bred with SD female rats to produce offspring carrying the *p53^{tm1(EGFP-pac)}* mutation.

Southern blot analysis

Genomic DNA was extracted from rat ES cells or rat tail biopsies using Puregene Tissue Core Kit A (Qiagen). 10µg genomic DNA from each sample was used for Southern blot analysis. After digestion with *SpeI* (for 5' and internal probes) or *HindIII* (for 3' probe), the genomic DNA samples were analyzed by gel electrophoresis with a 1% agarose gel. After electrophoresis, the gel was denatured, neutralized and blotted by capillary transfer with 20 × SSC on a nylon membrane as described²⁹. The DNA membrane was fixed and hybridized with digoxigenin labeled Southern blot hybridization probes according to the manufacture's instruction (Roche).

Genotyping

Rat tail genomic DNA was extracted using Puregene Tissue Core Kit A (Qiagen). 100ng of genomic DNA from each sample was mixed with PCR primers and used to amplify genomic DNA with Paq5000 DNA polymerase (Stratagene). Thermal cycling conditions were: 95°C for 2 min to denature the DNA, followed by 95°C for 20 sec, 62°C for 20 sec and 72°C for 20 sec for 40 cycles.

Northern blot analysis

Total RNA was extracted from different organs of 2-week old wild-type, *p53* heterozygote and *p53* homozygote rats using the RNeasy kit (Qiagen). 3µg total RNA from each sample was separated by gel electrophoresis with a 1% denaturing formaldehyde gel in 1×MOPS buffer and blotted onto positively charged nylon membrane in 20× SSC. The RNA membrane was fixed by UV-crosslinking and hybridized with the digoxigenin labeled *p53* cDNA probe according to the manufacture's instruction (DIG Northern Starter kit, Roche).

p53 cDNA template used for preparing the probe was generated by PCR using primers 5'-atg gag gat tca cag tcg gat at-3' and 5'-aaa tgg caa gaa agg agg g-3'.

Western blot analysis

Whole cell lysate was prepared from different organs of 2-week old wild-type, *p53* heterozygote and *p53* homozygote rats. 30µg of whole cell lysate from each sample was separated by SDS-PAGE and analyzed by Western blot with the *p53* primary antibody (Cell Signaling Technology, #2524) using the standard protocol²⁹.

Supplementary Material

Refer to Web version on PubMed Central for supplementary material.

Acknowledgments

This work was supported by a NIH/NCRR grant to Q.L.Y (1R01 RR025881). We thank members of the Ying lab and the USC Stem Cell Core for technical assistance; G. Chester for ordering rats; R. Montano and colleagues for rat husbandry; T. Saunders, E. Bryda and M. Pera for critical reading of the manuscript; E. Kho for financial support. We are also grateful to M. Pera and R. Maxson for their support and encouragement.

References

1. Capecchi MR. Gene targeting in mice: functional analysis of the mammalian genome for the twenty-first century. *Nat Rev Genet.* 2005; 6:507–512. [PubMed: 15931173]
2. Buehr M, et al. Capture of authentic embryonic stem cells from rat blastocysts. *Cell.* 2008; 135:1287–1298. [PubMed: 19109897]
3. Li P, et al. Germline competent embryonic stem cells derived from rat blastocysts. *Cell.* 2008; 135:1299–1310. [PubMed: 19109898]
4. Gill TJ 3rd, Smith GJ, Wissler RW, Kunz HW. The rat as an experimental animal. *Science (New York NY).* 1989; 245:269–276.
5. Jacob HJ. Functional genomics and rat models. *Genome research.* 1999; 9:1013–1016. [PubMed: 10568741]
6. Aitman TJ, et al. Progress and prospects in rat genetics: a community view. *Nat Genet.* 2008; 40:516–522. [PubMed: 18443588]
7. Jacob HJ, Kwitek AE. Rat genetics: attaching physiology and pharmacology to the genome. *Nature Rev Genet.* 2001; 3:33–42. [PubMed: 11823789]
8. Kitada K, et al. Transposon-tagged mutagenesis in the rat. *Nature methods.* 2007; 4:131–133. [PubMed: 17220894]
9. Izsvak Z, et al. Generating knockout rats by transposon mutagenesis in spermatogonial stem cells. *Nature methods.* 2010; 7:443–445. [PubMed: 20473302]
10. Zan Y, et al. Production of knockout rats using ENU mutagenesis and a yeast-based screening assay. *Nature biotechnology.* 2003; 21:645–651.
11. Geurts AM, et al. Knockout rats via embryo microinjection of zinc-finger nucleases. *Science (New York, N Y).* 2009; 325:433.
12. Cozzi J, et al. Pronuclear DNA injection for the production of transgenic rats. *Methods in molecular biology (Clifton, N J).* 2009; 561:73–88.
13. Lu B, et al. Generation of rat mutants using a coat color-tagged Sleeping Beauty transposon system. *Mamm Genome.* 2007; 18:338–346. [PubMed: 17557177]
14. Mashimo T, et al. Generation of knockout rats with X-linked severe combined immunodeficiency (X-SCID) using zinc-finger nucleases. *PloS one.* 2010; 5:e8870. [PubMed: 20111598]
15. Ying QL, et al. The ground state of embryonic stem cell self-renewal. *Nature.* 2008; 453:519–523. [PubMed: 18497825]

16. Levine AJ, Momand J, Finlay CA. The p53 tumour suppressor gene. *Nature*. 1991; 351:453–456. [PubMed: 2046748]
17. McCarrick JW 3rd, Parnes JR, Seong RH, Solter D, Knowles BB. Positive-negative selection gene targeting with the diphtheria toxin A-chain gene in mouse embryonic stem cells. *Transgenic research*. 1993; 2:183–190. [PubMed: 8364601]
18. Liu X, et al. Trisomy eight in ES cells is a common potential problem in gene targeting and interferes with germ line transmission. *Dev Dyn*. 1997; 209:85–91. [PubMed: 9142498]
19. Nagy A, Rossant J, Nagy R, Abramow-Newerly W, Roder JC. Derivation of completely cell culture-derived mice from early-passage embryonic stem cells. *Proceedings of the National Academy of Sciences of the United States of America*. 1993; 90:8424–8428. [PubMed: 8378314]
20. Hughes ED, et al. Genetic variation in C57BL/6 ES cell lines and genetic instability in the Bruce4 C57BL/6 ES cell line. *Mamm Genome*. 2007; 18:549–558. [PubMed: 17828574]
21. Adams DJ, van der Weyden L. Contemporary approaches for modifying the mouse genome. *Physiological genomics*. 2008; 34:225–238. [PubMed: 18559964]
22. Kuhn R, Torres RM. Cre/loxP recombination system and gene targeting. *Methods in molecular biology (Clifton, NJ)*. 2002; 180:175–204.
23. Belteki G, et al. Conditional and inducible transgene expression in mice through the combinatorial use of Cre-mediated recombination and tetracycline induction. *Nucleic acids research*. 2005; 33:e51. [PubMed: 15784609]
24. Feil R. Conditional somatic mutagenesis in the mouse using site-specific recombinases. *Handbook of experimental pharmacology*. 2007:3–28. [PubMed: 17203649]
25. Nagy, A.; Gertsenstein, M.; Vintersten, K.; Behringer, R. *Manipulating the mouse embryo, a laboratory manual*. 3. Cold Spring Harbor Laboratory Press; New York, USA: 2003.
26. Tybulewicz VL, Crawford CE, Jackson PK, Bronson RT, Mulligan RC. Neonatal lethality and lymphopenia in mice with a homozygous disruption of the c-abl proto-oncogene. *Cell*. 1991; 65:1153–1163. [PubMed: 2065352]
27. Niwa H, Yamamura K, Miyazaki J. Efficient selection for high-expression transfectants with a novel eukaryotic vector. *Gene*. 1991; 108:193–199. [PubMed: 1660837]
28. Ying QL, Nichols J, Chambers I, Smith A. BMP induction of Id proteins suppresses differentiation and sustains embryonic stem cell self-renewal in collaboration with STAT3. *Cell*. 2003; 115:281–292. [PubMed: 14636556]
29. Sambrook, J.; Russell, DW. *Molecular cloning: a laboratory manual*. Cold Spring Harbor Laboratory press; New York: 2001.

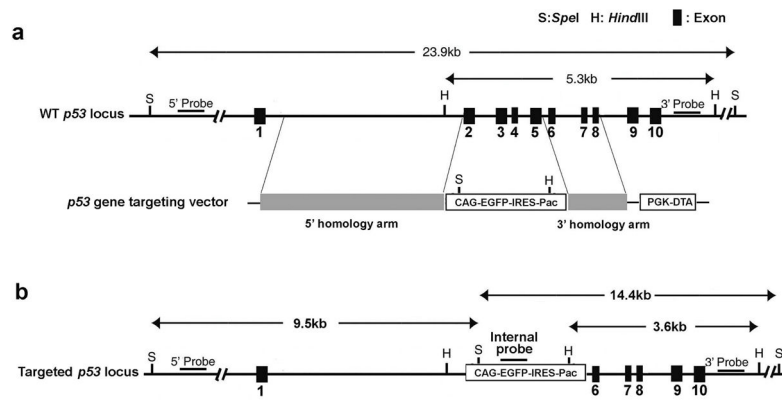

Figure 1. Schematic diagram showing the strategy to disrupt the rat *p53* gene via homologous recombination

a, Structures of the wild-type (WT) rat *p53* gene allele and the rat *p53* gene targeting vector.

b, The predicted structure of the gene-targeted rat *p53^{tm1(EGFP-pac)}* allele.

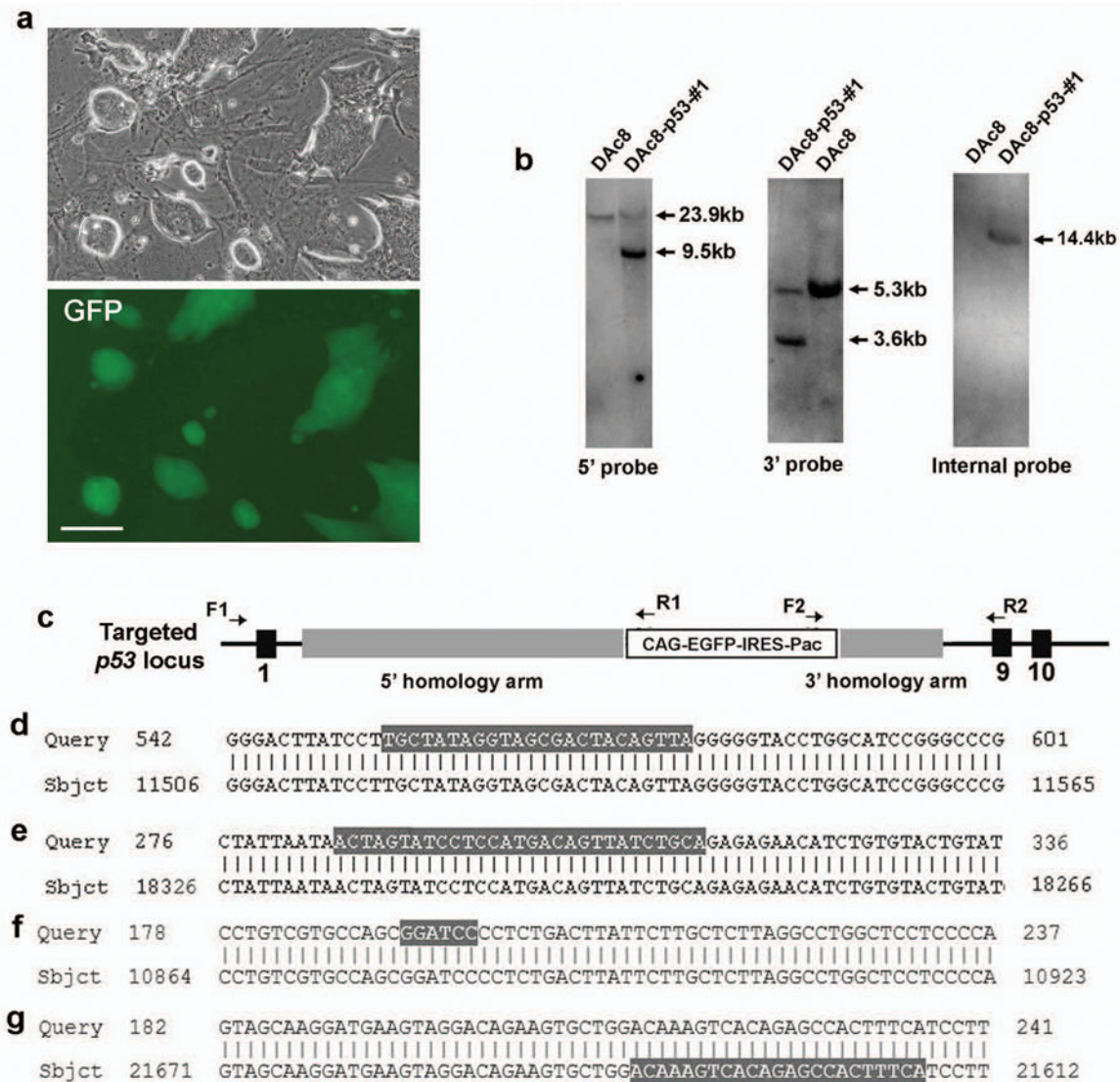

Figure 2. Confirmation of *p53* gene targeting in rat ES cells

a, Phase-contrast and fluorescence images of DAC8-p53-#1 rat ES cells. Scale bar, 50 μ m. **b**, Southern-blot analysis of *p53* gene-targeted rat ES cells using 5', 3' or internal probes. For Southern blot analysis with 5' or internal probes, genomic DNA from rat ES cells was digested with *SpeI*. For Southern blot analysis using 3' probe, rat ES cell genomic DNA was digested with *HindIII*. The expected sizes of wild-type and *p53* gene-targeted bands with different probes are shown in Fig. 1. **c**, The diagram showing the positions of two PCR primer pairs. **d-g**, Sequence alignment of PCR products amplified from DAC8-p53-#1 rat ES cells. The sequence of the PCR product (Query) amplified using the first pair of primers (F1 and R1) was aligned with the sequences of the rat genome (**d**) or the *p53* gene targeting vector (**e**). The sequence of the PCR product amplified using the second pair of primers (F2 and R2) was aligned with the sequences of the *p53* gene targeting vector (**f**) or the rat genome (**g**). The highlighted sequences represent the junctions between the homology arms and the rat genome (**d** and **g**) or the CAG-EGFP-IRES-Pac cassette (**e** and **f**).

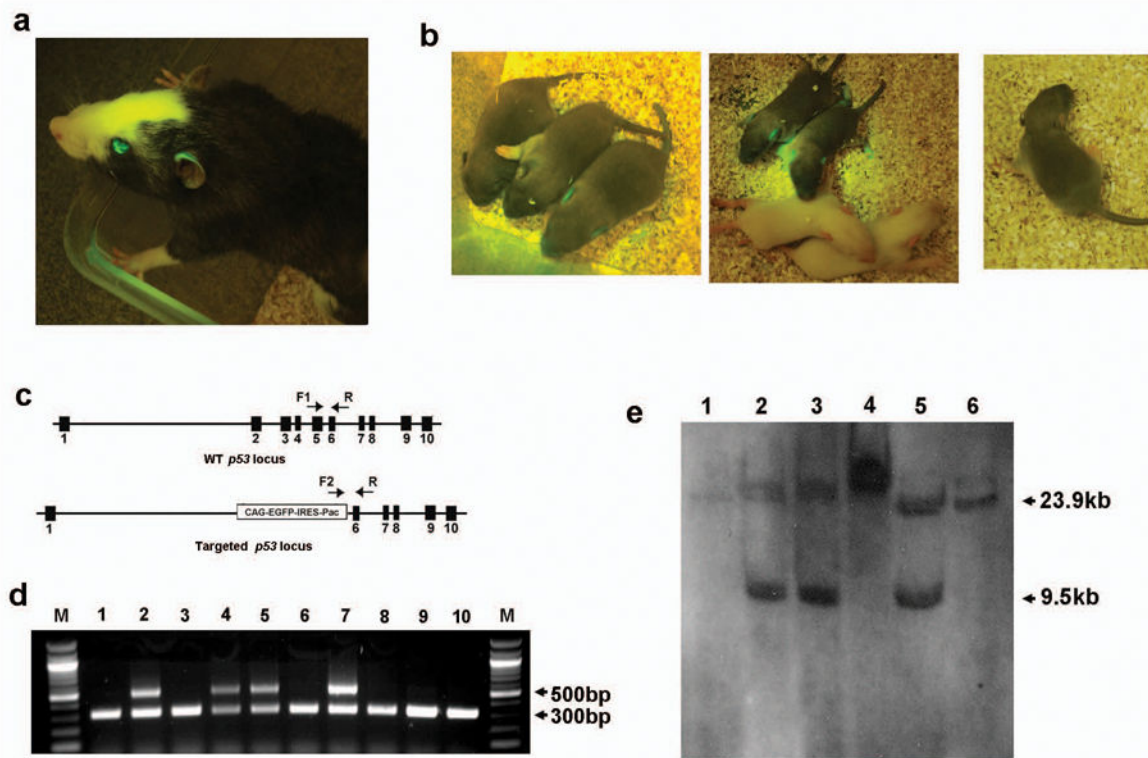

Figure 3. Germline transmission of the *p53* gene-targeted mutation in the rat

a, The male chimera generated from the DAC8-*p53*-#1 subclone. The agouti coat color and the appearance of GFP-positive tissues indicate that *p53* gene-targeted DAC8 rat cells were present in the ES cell-rat chimera. **b**, Offspring produced by breeding the male chimera shown in (**a**) with SD female rats. **c**, Diagrams showing the positions of three PCR primers designed for genotyping *p53* gene-targeted offspring. F1: gcg ttg ctc tga tgg tga c; F2: tgc ggt ggg ctc tat ggc ttc t; R: cag cgt gat gat ggt aag gat. The expected sizes of PCR products for wild-type and *p53* gene-targeted alleles are 309bp and 498bp, respectively. **d**, PCR genotyping analysis of the *p53* gene-targeted allele. M, 100bp DNA marker; 1, DAC8 rat ES cells; 2, DAC8-*p53*-#1 rat ES cells; 3, 6, and 8, the three GFP-negative germline offspring; 4, 5, and 7, the three GFP-positive offspring; 9 and 10, the two albino littermates. **e**, Southern blot analysis for the *p53* gene-targeted allele using the 5' probe. 1, 4, and 6 are the three GFP-negative germline offspring; 2, 3, and 5 are the three GFP-positive offspring.

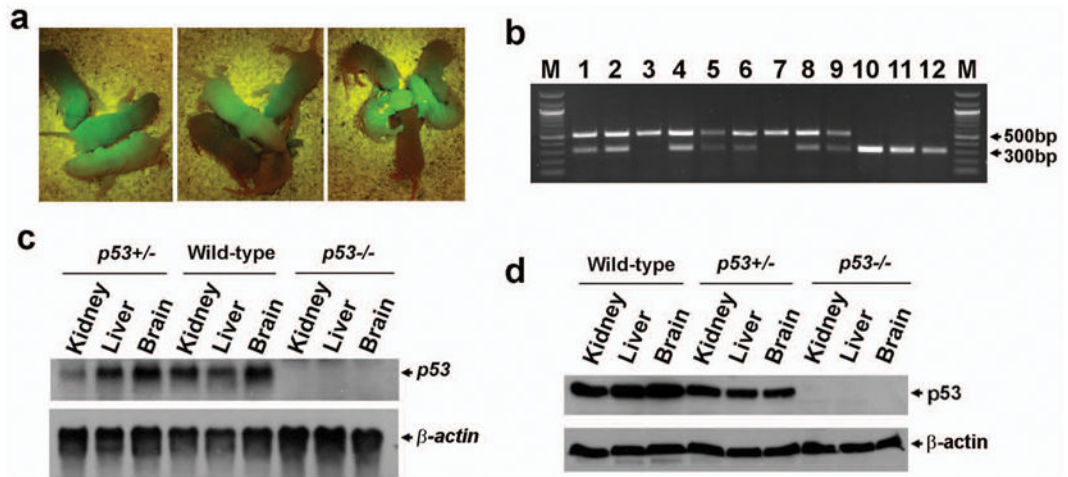

Figure 4. Generation of $p53$ gene knockout rats

a, Offspring generated by intercrossing $p53^{tm1(EGFP-pac)}$ heterozygote rats. **b**, Genotyping analysis on tail biopsies using PCR primers shown in Fig. 3c. M, 100bp DNA marker; 1–9, the nine GFP-positive offspring; 3 and 7, the two $p53^{tm1(EGFP-pac)}$ homozygote pups; 10–12, the three GFP-negative offspring. **c**, Detection of $p53$ mRNA by Northern blot. Northern analysis was performed by sequential hybridization with probes for $p53$ and β -actin. **d**. Detection of p53 protein by Western blot.