



# Interactions of *Salmonella enterica* Serovar Typhimurium and *Pectobacterium carotovorum* within a Tomato Soft Rot

Andrée S. George,<sup>a</sup> Clayton E. Cox,<sup>a</sup> Prerak Desai,<sup>b</sup> Steffen Porwollik,<sup>b</sup> Weiping Chu,<sup>b</sup> Marcos H. de Moraes,<sup>a</sup> Michael McClelland,<sup>b</sup> Maria T. Brandl,<sup>c</sup> Max Teplitski<sup>a</sup>

<sup>a</sup>Soil and Water Science Department, Genetics Institute, University of Florida-IFAS, Gainesville, Florida, USA

<sup>b</sup>Department of Microbiology and Molecular Genetics, University of California, Irvine, Irvine, California, USA

<sup>c</sup>Produce Safety and Microbiology Research Unit, Western Regional Research Center, Agricultural Research Service, U.S. Department of Agriculture, Albany, California, USA

**ABSTRACT** *Salmonella* spp. are remarkably adaptable pathogens, and this adaptability allows these bacteria to thrive in a variety of environments and hosts. The mechanisms with which these pathogens establish within a niche amid the native microbiota remain poorly understood. Here, we aimed to uncover the mechanisms that enable *Salmonella enterica* serovar Typhimurium strain ATCC 14028 to benefit from the degradation of plant tissue by a soft rot plant pathogen, *Pectobacterium carotovorum*. The hypothesis that in the soft rot, the liberation of starch (not utilized by *P. carotovorum*) makes this polymer available to *Salmonella* spp., thus allowing it to colonize soft rots, was tested first and proven null. To identify the functions involved in *Salmonella* soft rot colonization, we carried out transposon insertion sequencing coupled with the phenotypic characterization of the mutants. The data indicate that *Salmonella* spp. experience a metabolic shift in response to the changes in the environment brought on by *Pectobacterium* spp. and likely coordinated by the *csrBC* small regulatory RNA. While *csrBC* and *flhD* appear to be of importance in the soft rot, the global two-component system encoded by *barA sirA* (which controls *csrBC* and *flhDC* under laboratory conditions) does not appear to be necessary for the observed phenotype. Motility and the synthesis of nucleotides and amino acids play critical roles in the growth of *Salmonella* spp. in the soft rot.

**IMPORTANCE** Outbreaks of produce-associated illness continue to be a food safety concern. Earlier studies demonstrated that the presence of phytopathogens on produce was a significant risk factor associated with increased *Salmonella* carriage on fruits and vegetables. Here, we genetically characterize some of the requirements for interactions between *Salmonella* and phyto bacteria that allow *Salmonella* spp. to establish a niche within an alternate host (tomato). Pathways necessary for nucleotide synthesis, amino acid synthesis, and motility are identified as contributors to the persistence of *Salmonella* spp. in soft rots.

**KEYWORDS** food safety, *Pectobacterium*, produce, *Salmonella*, microbe-microbe interactions, transposons

Although traditionally associated with products of animal origin, over the last decade, multistate outbreaks of nontyphoidal *Salmonella* spp. associated with produce highlight the need to further understand the ecology of this human pathogen in alternate hosts, such as plants. Despite advances in understanding how this pathogen contaminates produce (1, 2), salmonellosis outbreaks linked to the consumption of fresh fruits and vegetables continue to present a global problem. Interactions between *Salmonella* spp. and the native microbial communities are hypothesized to contribute to the ability of this human pathogen to colonize plants (3–8). It has been reported that

Received 30 August 2017 Accepted 7 December 2017

Accepted manuscript posted online 15 December 2017

**Citation** George AS, Cox CE, Desai P, Porwollik S, Chu W, de Moraes MH, McClelland M, Brandl MT, Teplitski M. 2018. Interactions of *Salmonella enterica* serovar Typhimurium and *Pectobacterium carotovorum* within a tomato soft rot. *Appl Environ Microbiol* 84:e01913-17. <https://doi.org/10.1128/AEM.01913-17>.

**Editor** Andrew J. McBain, University of Manchester

**Copyright** © 2018 George et al. This is an open-access article distributed under the terms of the [Creative Commons Attribution 4.0 International license](https://creativecommons.org/licenses/by/4.0/).

Address correspondence to Andrée S. George, [aegorge@ufl.edu](mailto:aegorge@ufl.edu).

[This article was published on 14 February 2018 with Steffen Porwollik's surname misspelled as "Porwollik" in the byline and self-citation. The byline was updated in the current version, posted on 24 April 2018.]

*Salmonella enterica* strains may benefit from the presence of plant pathogens, such as *Pectobacterium carotovorum*, *Dickeya dadantii*, and *Xanthomonas* spp. (3, 7, 9). These bacteria cause disease on various plants, including leafy greens and tomatoes, and represent a risk factor for the increased likelihood of produce contamination with enterics (4, 6, 7). Several mechanisms underlying these interactions have been examined. Quorum sensing signal exchange between *Salmonella* and *Pectobacterium* spp., changes in the response of *Salmonella* spp. to the environment and the uptake of nutrients from degraded plant tissue have all been tested, although none of them fully account for the ability of *Salmonella* spp. to efficiently colonize lesions created by phytopathogens (3, 10–12).

Interactions with other bacteria are an important factor in the successful colonization of plant surfaces and tissues by *Salmonella* spp., although the importance to internal colonization remains understudied (1, 3). One of the tested hypotheses was that *Salmonella* spp. sense production of the population density-dependent signals by other bacteria within the soft rot and respond accordingly (10). While *Salmonella* spp. are known to possess the ability to detect *N*-acyl homoserine lactone (AHL) bacterial quorum sensing signals via the LuxR homologue SdiA (10, 13, 14), the exact function of this protein remains elusive (15, 16). While *Salmonella* spp. detected AHLs from *Pectobacterium* strains *in vitro*, the *sdiA* gene was expressed at a low level inside the tomato fruit or the soft rot, and, consequentially, the deletion of this regulator did not significantly impact fitness within soft rots (10). The deletion of the *Salmonella* second quorum sensing (QS) system mediated by the autoinducer 2 (AI-2) had no effect on growth in tomatoes with or without *Pectobacterium carotovorum*, providing further evidence that these two QS-mediated signal exchanges are not a driving force of this interaction (11).

Nutrient exchange or environmental change due to soft rot likely explains the growth benefit gained by *Salmonella* species. Transcriptomic studies of *Salmonella* spp. in *D. dadantii* soft rot lesions on cilantro and lettuce have shown that *Salmonella* spp. use distinct metabolic pathways and take advantage of the substrates and physico-chemical conditions that result from the maceration of leaf tissue by soft rotters (7). While *Salmonella* spp. clearly benefit from the presence of *Pectobacterium* spp., the mechanisms behind this phenomenon remain unclear. The process by which the plant cell wall-degrading enzymes (PCWDEs) of *Pectobacterium* spp. macerate plant tissue is well established (17–19). Changes in macerated plant tissue, such as a decrease in pH (20), the freeing of carbohydrate monomers and of starch (which is not metabolized by *Pectobacterium* spp.), and regulation of plant defenses in the early stages of infection create an environment in which *Salmonella* spp. are able to thrive (6, 21). Indeed, it has been shown that damage to plants, whether mechanical or microbial, enhances colonization by enteric pathogens (22). The release of nutrients from plant tissues provides a means for the survival for soft rot plant pathogens, such as *Pectobacterium carotovorum* (18, 19, 23). *Salmonella* spp., which do not possess PCWDEs, may scavenge the products released by the enzymatic activity of *Pectobacterium* species. Previously, we established that the deletion of the *kdgR* gene, which codes for a repressor of cell wall degradation and uptake of monomers and dimers resulting from the plant cell wall breakdown, was beneficial to the growth of *S. enterica* serovar Typhimurium strain ATCC 14028 (*S. Typhimurium* 14028) in soft rot (24). However, further investigation of the KdgR regulon did not offer a conclusive explanation for its role in the ability of *Salmonella* spp. to benefit from the presence of *Pectobacterium* species.

To obtain a more comprehensive picture of the biology of *Salmonella* spp. in *Pectobacterium* soft rot, we made use of a transposon-derived mutant library which we screened for both deleterious and beneficial mutations. This transposon insertion analysis indicates that motility and amino acid and nucleotide synthesis are important for the growth of *S. Typhimurium* 14028 in soft rot.

## RESULTS

**Plant maceration, and not the presence of *Pectobacterium carotovorum per se*, provides a benefit to *S. Typhimurium* 14028.** As shown in previous reports, *Salmo-*

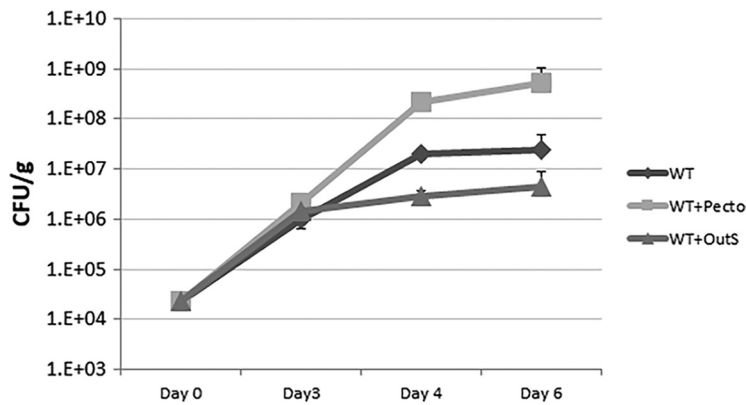

**FIG 1** Growth curves of wild-type *Salmonella* in tomatoes. Tomatoes were treated with no *Pectobacterium carotovorum* (wild type [WT]), with *Pectobacterium carotovorum* (WT + Pecto), and with a *Pectobacterium*  $\Delta outS$  mutant (WT + OutS). Cells were plated on xylose lysine deoxycholate (XLD) agar in triplicate ( $n = 6$  to  $9$ ) in and counted after 3, 4, and 6 days. Error bars reflect the standard error. Final concentrations are significantly different ( $P < 0.05$ ).

*Salmonella enterica* serovar Typhimurium strains reach higher cell numbers in tomatoes macerated by the plant pathogens of *Pectobacterium* than in intact tomatoes (6, 10, 12). To test the hypothesis that *P. carotovorum* degradation of plant tissue, and not the presence of the plant pathogen *per se*, promoted the growth of *S. Typhimurium* 14028, we constructed an *outS* mutant in *Pectobacterium carotovorum* strain WP114. This mutation results in bacteria that are unable to secrete the enzymes responsible for the breakdown of the plant cell wall (25). Expectedly, the resulting *P. carotovorum* mutant is unable to effectively secrete pectate lyases. In tomatoes infected with the *P. carotovorum* *outS* mutant, there were no visible signs of the characteristic soft rot disease progression (see Fig. S1 in the supplemental material). This observation is consistent with the previous report of the significantly reduced virulence of *P. carotovorum* *outS* mutants in other strains of this pathogen (26). Prior to the appearance of disease symptoms caused by the wild-type *Pectobacterium* bacterium (day 3), *S. Typhimurium* 14028 reached  $\sim 10^6$  CFU/g in all three sample groups: tomatoes only, tomatoes infected with *P. carotovorum* SR38, and tomatoes with the *P. carotovorum* *outS* mutant (Fig. 1). However, once soft rot symptoms developed in tomatoes infected with wild-type *P. carotovorum* SR38, the populations of *S. Typhimurium* 14028 reached  $10^9$  CFU/g. In contrast, the growth of *S. Typhimurium* 14028 in tomatoes that were free of *Pectobacterium carotovorum* reached a maximum density of about  $10^7$  CFU/g; in tomatoes coinfecting with *S. Typhimurium* 14028 and an *outS* mutant of *P. carotovorum*, the population sizes of *S. Typhimurium* 14028 did not occur to the same extent and were  $\sim 100$ -fold less than those in soft rotted tomatoes and 10-fold less than those in the *Salmonella*-only control tomato (Fig. 1). Statistical analysis showed that final population sizes were significantly different from each other ( $P < 0.05$ ). This test supported the null hypothesis that plant maceration, and not the presence of *Pectobacterium carotovorum* *per se*, leads to substantial growth increase of *S. Typhimurium* 14028.

***Salmonella* starch utilization genes are upregulated but not required for fitness within soft rots.** *P. carotovorum* is known to liberate amylose and amylopectin as a consequence of the degradation of the integrity of plant cells. *P. carotovorum* lacks the ability to utilize starch (27, 28). Because *Salmonella* spp. are capable of digesting starch (29), which can be up to 10% dry weight in mature green tomatoes (30, 31), we tested the hypothesis that this human pathogen benefits from the soft rot due to its ability to utilize starch that is liberated and unused by *P. carotovorum*. This approach was two-pronged and involved first an assessment of the expression of the *Salmonella* *malS* and *amyA* genes involved in starch utilization, and second, a determination of the fitness of corresponding mutants in intact and macerated tomato fruit tissue. In order to assess the expression, recombination-based *in vivo* expression technology (RIVET)

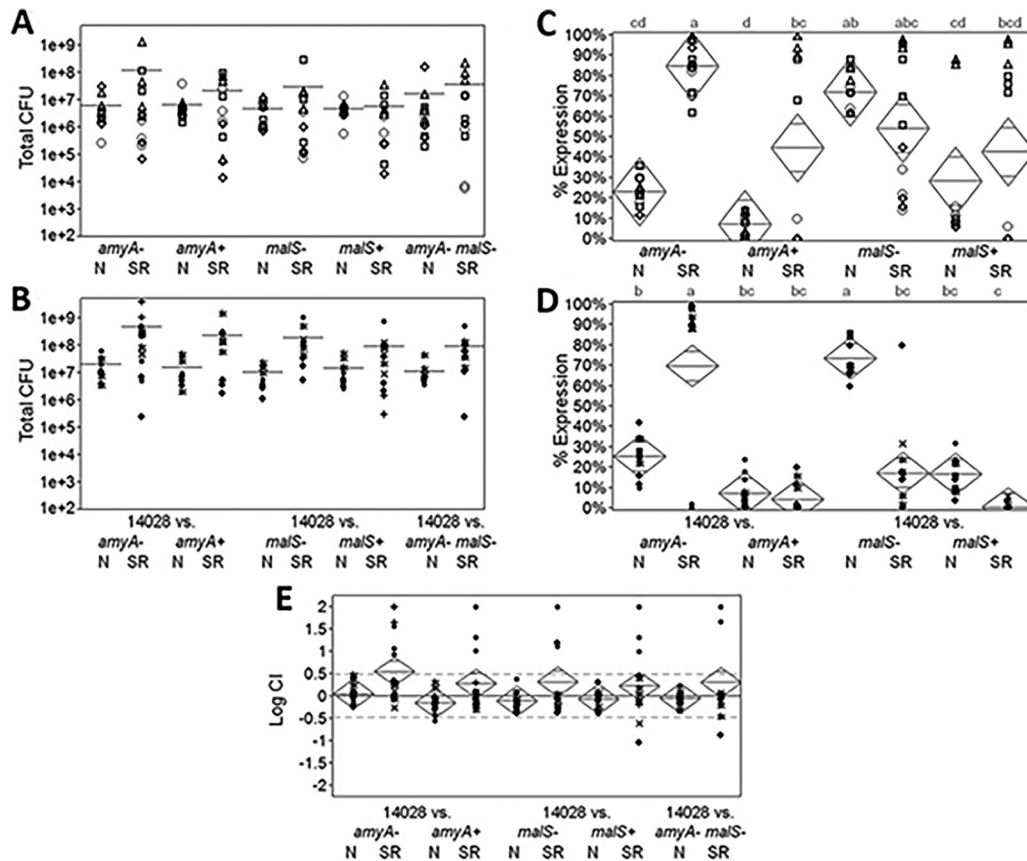

**FIG 2** Function of *amyA* and *malS*. *In vivo* assays in normal (N) or soft-rotted (SR) green tomatoes. (A) Single infections of marked  $\alpha$ -amylase mutants.  $n \geq 11$ . (B) Coinfections between marked  $\alpha$ -amylase mutants and WT *S. Typhimurium* 14028.  $n \geq 9$ . Bars show group means. Different markers represent samples from the same independent experiments. No differences were significant, as determined by the Tukey honestly significant difference (HSD) test. (C) Percent resolution of *tetR* in RIVET reporter promoter-*tnpR* (- mutants) or gene-*tnpR* (+ mutants) fusions in single infections with  $\alpha$ -amylase mutants only.  $n = 12$ . (D) Percent resolution of *tetR* in RIVET reporters in coinfections with marked  $\alpha$ -amylase mutants and WT *S. Typhimurium* 14028.  $n \geq 12$ . (E) Competitive fitness between WT *S. Typhimurium* 14028 and marked  $\alpha$ -amylase mutants during coinfections. Diamonds show means and 95% confidence interval bars at the top and bottom. Different markers represent samples from the same independent experiments. Lowercase letters identify significance groups, as determined by the Tukey HSD test.

was employed (32). Expression is measured as the percentage of cells which become susceptible to tetracycline as a result of the activation of the promoter of interest and the associated excision of the tetracycline cassette-containing reporter marker. As shown in Fig. 2, RIVET revealed that *amyA* was expressed only modestly in intact tomatoes (5 to 20%) but strongly (70 to 100%) in soft rots. The strongest induction was observed in *amyA* mutants, suggesting the presence of a feedback mechanism that likely depends on the availability of either the substrate or the degradation products. The basal expression level of *malS*, which encodes a periplasmic  $\alpha$ -amylase (33), was higher than that of *amyA*. In intact tomatoes, *malS* was expressed at 5 to 80%, while expression in soft rotted tomatoes was generally lower, although more varied. As with *amyA*, the expression patterns of *malS* suggest feedback regulation, as the expression of the *malS* RIVET reporter was highest in the *malS* mutant background. We observed some variability in the activation of *amyA* and *malS* reporters in soft rots, perhaps representative of the inherent heterogeneity of this environment. We then tested the fitness of the *Salmonella amyA* and *malS* mutants in soft rots and in intact green tomatoes compared to that of the wild-type *Salmonella* bacteria. As shown in Fig. 2E, there were no significant differences in the fitness of the mutants under any of the tested conditions. Therefore, the hypothesis that the benefits derived by *Salmonella*

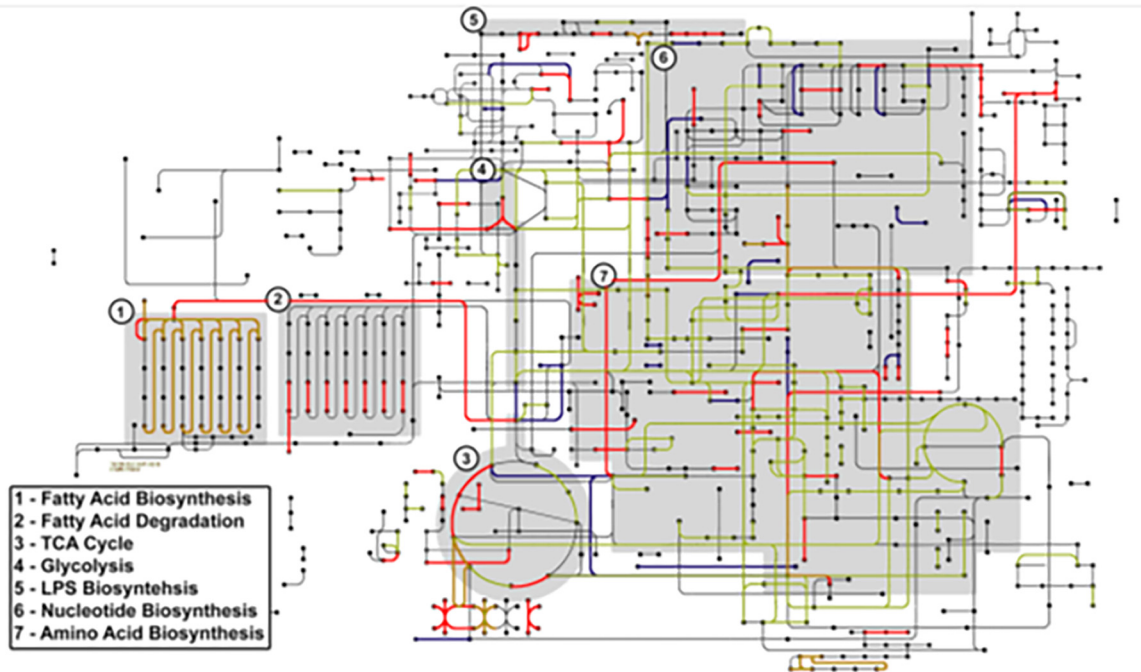

**FIG 3** *Salmonella* metabolic pathways affected by soft rot. Map of *Salmonella* metabolism downloaded from the Kyoto Encyclopedia of Genes and Genomes (KEGG) constructed from transposon insertion analysis (TIA) data. Lines represent genes under negative selection in the soft rot (blue), intact fruit, (red) and both conditions (green).

spp. from soft rot disease are due to their ability to scavenge starch via *amyA* and *malS* was proven null.

**Transposon insertion analysis reveals differences between metabolic pathways necessary for growth in the intact and soft rot tomatoes.** Having previously reported that *kdgR* alone is not responsible for the growth of *S. Typhimurium* 14028 in soft-rotted tomatoes (24) and in light of the fact that the starch-scavenging hypothesis was proven null, we performed a high-throughput assay in order to identify the full complement of genes responsible for this interaction. Transposon sequencing (Tn-Seq) has become an important tool for untangling complex metabolic networks in *Salmonella* spp. in a variety of habitats (34, 35). Here, we use a similar technique, transposon insertion analysis, to identify mutations that affect the ability of *S. Typhimurium* 14028 to grow in green tomatoes with and without soft rot.

In plants, enteric pathogens rely on a distinct set of genes in order to be competitive against the native microbiota (7, 36, 37). Libraries of *S. Typhimurium* 14028 mutants constructed with tagged transposons were seeded into intact green tomatoes, green tomatoes rotted with *Pectobacterium carotovorum*, and green tomatoes inoculated with a *Pectobacterium outS* mutant. Generally, similar *Salmonella* functions appear to be involved in the persistence within the intact tomatoes and those infected with the *outS* mutant (Fig. S2). This further supports the assertion that the soft rot, and not the presence of *Pectobacterium carotovorum*, is responsible for the observed growth increase. Overall, there was a large number of mutations that reduced *Salmonella* fitness in the soft rot and nearly as many mutants that benefited from the soft rot. Indeed, ~600 mutants (~54%) were less competitive in the soft rot than in the intact tomato, and ~500 mutants (~46%) (false-discovery rate [FDR], <0.05) were more competitive than the wild-type strain (Fig. S3).

The transposon mutant screen revealed that most insertion mutations were deleterious in both the intact and soft rot tomatoes, with ~300 individual mutations causing growth to a significantly lesser extent (FDR, <0.05) than the wild type (Table S1). Within intact tomatoes, ~220 mutations were deleterious, while only ~50 mutations were deleterious in soft rots. Figure 3 is a graphical representation of these findings with pathways down-

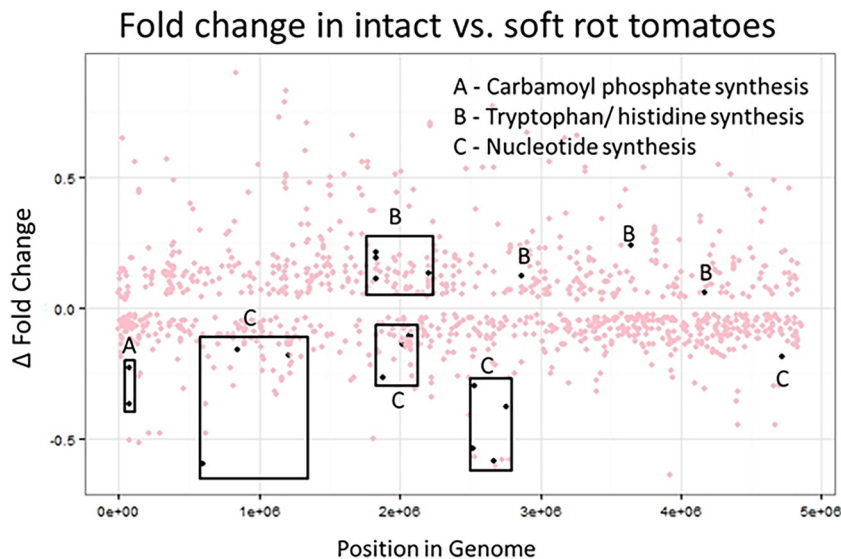
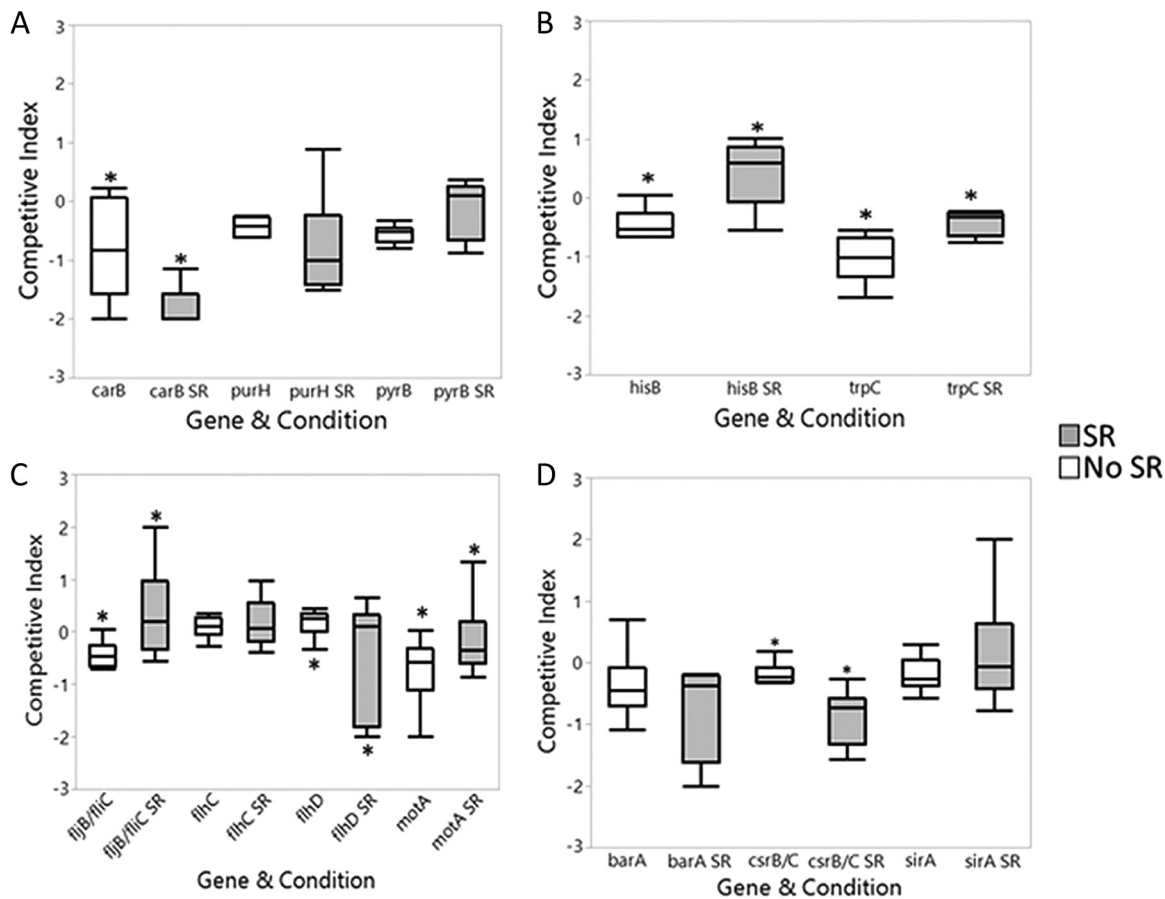

**FIG 4** Comparison of genes more or less fit in the soft rot and intact tomatoes. Dots represent significant differences (FDR, <0.05) in the fold change of mutants grown in both tomatoes with soft rot and with no soft rot. Negative values indicate the mutant is at a disadvantage, while positive values indicate a benefit. Black dots are genes which belong to a grouping (A, B, or C) and also cluster on the positive or negative side of the graph.

loaded from the Kyoto Encyclopedia of Genes and Genomes (KEGG). While fatty acid biosynthesis appears to be necessary under both conditions, their degradation seems important only in the intact fruit. The tricarboxylic acid cycle (TCA) also plays a role in both conditions, either directly by providing nutrients for *Salmonella* growth or indirectly through impacting energy yields. However, the conversion of oxoglutarate to succinyl-coenzyme A (succinyl-CoA) and the two-step conversion of fumarate to oxaloacetate were more important in the intact tomato. This supports previous evidence that *S. Typhimurium* 14028 is capable of using alternate metabolic pathways in the soft rot (24). For the most part, with the exception of the mannose-6-phosphate isomerase mutant (*manA*), mutants impaired in glycolytic pathways were less fit in intact fruit. Additionally, with the exception of *rfaF*, which was less competitive in both the soft rot and intact tomatoes, mutants in the lipopolysaccharide (LPS) genes were less competitive in the intact tomato than in soft rot. Finally, we observed that the mutations in nucleotide biosynthesis pathways were the only ones that resulted in the enhanced growth within soft rot. These data show that *S. Typhimurium* 14028 does not use the same essential functions in soft rot and intact tomato tissue.

**Nucleotide synthesis is required for growth of *Salmonella* in soft rot.** Nucleotide synthesis is a necessary step in the replication of DNA and cellular growth. We observed that mutants in genes involved in *de novo* nucleotide synthesis cluster on the negative side of the log scale (Fig. 4). This indicates that mutations in genes involved in purine and pyrimidine synthesis impart a significant disadvantage against the wild-type strain in the soft rot. Among these genes are the *pyr*, *pur*, and *car* genes. The *pyr* and *pur* genes are involved in pyrimidine and purine synthesis, respectively, while the *carAB* gene cluster is involved in the synthesis of arginine and pyrimidines. While the screen results indicate that control of purine and pyrimidine synthesis is important for *Salmonella* persistence in the soft rot, the individual competition assays showed no significant loss of fitness due to these mutations (Fig. 5A). However, the loss of fitness by *carB*, which is controlled by purine and pyrimidine levels (38), and the results support the notion that nucleotide synthesis is important.

**Amino acid synthesis is not required for growth in the soft rot.** *De novo* amino acid synthesis is important in environments where adequate nutrients are not supplied. It has been demonstrated that in seedlings and ripe tomatoes, *Salmonella* spp. require



**FIG 5** Competition assays in soft rotted and intact tomatoes. Assays were performed by first inoculating the tomatoes with 1:1 “in” ratio of wild type to mutant strains. After 3 days, the bacteria are harvested and grown on XLD agar at 42°C. The colonies were then patched onto LB with antibiotic to establish the “out” ratio of wild type to mutant. The  $\log_{10}$  of the out ratios of tomatoes with no soft rot (no SR) and those with soft rot (SR) were then compared. Analysis was performed using Student’s *t* test. Asterisks signify statistical differences ( $P < 0.05$ ). Genes tested were those involved in nucleotide synthesis (A), amino acid synthesis (B), motility (C), and regulation (D).

*de novo* amino acid synthesis (39, 40). As shown in Fig. 4, among the many mutants that outperformed the wild type in the soft rot were mutants of genes that were necessary for amino acid synthesis, such as histidine and tryptophan, as well as a GDP 3'-diphosphate (ppGpp), which may affect histidine regulation (41). The results of our screen revealed that mutants deficient in the *de novo* synthesis of amino acids, such as those of histidine (*his*) and tryptophan (*trp*), outcompeted the wild type in soft rotted tomatoes (Fig. 4). The results of the individual competition assays with *hisB* and *trpC* mutants supported these findings (Fig. 5B). Carrari et al. have shown that amino acid concentrations are not fully depleted in mature green tomatoes (42). Therefore, the levels of these amino acids are likely high enough in the soft rot that *Salmonella* spp. are able to scavenge them from the environment and thus avoid the metabolic load of their synthesis.

**Control of motility is important in soft rots but not through BarA-SirA.** Motility is a well-known virulence factor in *Salmonella* species (43, 44). Taxis toward energy sources has been established as a necessity in the inflamed intestine (45, 46). In cilantro soft rots, it has been demonstrated that genes involved in motility are downregulated (7). Our screen identified a number of genes involved in motility and its regulation as being important for soft rot colonization. To separate the consequences of regulatory and structural mutations, we tested phenotypes of mutants lacking the motor (but with an intact, although nonfunctional, flagellum), flagella (but with a functional motor), as well as a number of regulatory mutants that have decreased motility. The competitive

advantage gained by nonmotile mutants suggests that a loss of function of the motor via *motA* and loss of the flagella in the *fljB fljC* mutant (Fig. 5C) provide a benefit in the soft rot. The competitive fitness of mutants in genes known to regulate motility revealed that the deletion of *csrB* and *csrC*, two small regulatory RNAs that regulate the function of the RNA-binding protein CsrA (33), resulted in reduced fitness of *Salmonella* spp. in the soft rot (Fig. 5D). However, the deletion of the two-component system BarA/SirA, which regulates the expression of the global Csr regulatory system (47–49), had a minimal effect on the fitness of *S. Typhimurium* 14028 in macerated tomato tissue (Fig. 5D). However, the deletion of *flhD*, but not *flhC*, which both function to regulate flagella (among other genes) (50–52), was deleterious (Fig. 5C). This is in line with the fact that the *flhDC* operon is controlled by CsrA (48, 53) and our finding that *csrB* and *csrC* increase *S. Typhimurium* 14028 growth in soft rot. Thus, motility appears to impede soft rot colonization by *S. Typhimurium* 14028, being regulated through an unknown regulatory cascade that does not directly involve CsrA.

## DISCUSSION

*Salmonella enterica* serovar Typhimurium is highly adaptable and, therefore, capable of survival in a broad range of hosts. The ability of non-typhoidal *Salmonella* spp. to scavenge nutrients in plant and animal hosts is key to their ability to establish within diverse niches (4, 54–57). Their ability to exploit increased oxygen levels resulting from the depletion of clostridia in animals, to exclusively utilize nutritional resources under anaerobic conditions during cocolonization of macerated leaf tissue with *D. dadantii*, and to inhibit native microbiota by acidifying the environment in plants are common examples of this adaptability (5, 7, 58, 59). While there are instances in which native microbiota inhibit *Salmonella* proliferation (60, 61), non-typhoidal *Salmonella* spp. also benefit from the host native microbiota. The presence of bacteria and fungi that degrade plant tissues commonly increased *Salmonella* cell numbers in/on plants by at least 10-fold in laboratory studies (3, 6, 7, 62). The uptake and catabolism of a broad range of nutrients released from the degraded plant tissue, or made available through its degradation, partly enable this growth enhancement (7, 9). Here, we highlight the impact of *de novo* amino acid synthesis, nucleotide synthesis, and motility on the colonization of tomato soft rot by *S. Typhimurium* 14028.

Competition for amino acids in plant environments may be more critical for bacterial growth than that for carbohydrates, although cross-feeding in microbial communities can occur (63, 64). Contrary to previous reports that *de novo* amino acid synthesis is required for the growth of *Salmonella* spp. in intact plants (39, 40), soft rot conditions appeared to alleviate this need, as revealed by the competitive advantage gained by auxotrophic mutants in this study. Whether *Salmonella* spp. can scavenge amino acids and outcompete *Pectobacterium* spp. or whether other unknown interactions eliminate the need for amino acid synthesis is unclear. Given that *Salmonella* spp. have the ability to metabolize nutrients that do not serve as substrates in native bacteria in a variety of hosts (3), including in soft lesions of cilantro and lettuce (7), it is possible that they derive amino acids from metabolic pathways particular to their growth in soft rot, rather than through energetically expensive *de novo* synthesis.

Despite differences in growth requirements by *Salmonella* spp. in plant soft rot and animal hosts, there are also significant similarities. Goudeau et al. (7) demonstrated a considerable overlap in genes upregulated in cilantro and lettuce soft rot, and in the animal intestine, with 76% of the genes involved in metabolic processes. Similarly, purine and pyrimidine synthesis have both been shown to be required for *Salmonella* colonization of mice, pigs, and red tomatoes (39, 65, 66). Our study revealed that mutations in pyrimidine and purine synthesis along with those in *carB* are also attenuated in the soft rot. Despite individual *pyr* and *pur* mutants not showing a significant disadvantage against the wild type in the competition assays, a negative trend can be seen, as revealed in the data analysis. Mutations in *carB*, which is regulated by pyrimidine and purines (38), showed the greatest attenuation in the soft rot. The performance of this mutant, which is blocked at an intermediate step in pyrimidine



biosynthesis, suggests that pyrimidine biosynthesis is in fact necessary in the soft rot (67). Although *carB* plays a role in motility and biofilm formation in *Xanthomonas* spp., the competitive advantage of the nonmotile mutants that we observed in soft rot suggests that it performs dissimilar functions under the two conditions (68).

It is well established that *Salmonella* motility is required for virulence in mouse models (45, 46, 69), although it does not appear to be necessary in macrophages (70). Our finding that motility is disadvantageous in tomato soft rot compared to intact tomatoes is surprising but consistent with the previously described transcriptome of *Salmonella* Typhimurium in cilantro and lettuce leaf macerated by a closely related soft rot pathogen, *D. dadantii* (7). This may be due to increased nutrient availability, which reduces the need for taxis toward substrates, or to the initially abundant presence of cellulose, which can inhibit the movement of flagella (71). Alternatively, the energy conserved by the lack of motility or flagellar synthesis could result in increases in biomass.

The effect of mutations in the pathways regulating flagellar synthesis indicates that there is a concerted effort to respond to the environment generated by soft rot. Despite *flhC* and *flhD* functioning together to activate flagellar genes (51), only the *flhD*-deficient mutant was less competitive against the wild type, while the *flhC*-deficient mutant remained neutral. The ability of FlhC or FlhD to regulate other pathways to include those involved in respiration and cell division may offer an explanation about the inconsistent phenotype imparted by these mutations (71–73). Mutations in *flhD* (but not *flhC*) have been shown to lead to an increased rate of cell division, especially prior to the stationary phase, and to contribute to higher cell numbers (but not biomass) in the stationary phase, which could also explain the phenotypes seen here (74). It is noteworthy that FlhC/D also regulates genes of the Entner-Doudoroff pathway, which are shown to be important in growth of *S. Typhimurium* 14028 in tomato soft rot (24, 72). The loss of fitness by the disruption of *flhD* supports previous evidence that this pathway is involved in the growth of *S. Typhimurium* 14028 in the soft rot (24). In addition, *csrB* and *csrC*, which antagonize CsrA (a positive regulator of the *flhC-flhD* complex), were also attenuated in the soft rot (53, 75). The phenotypes of both the *flhD* and *csrB csrC* mutants are consistent with our observation that motility is disadvantageous to *S. Typhimurium* 14028 in the soft rot. Finally, it is worth noting that while a *csrB csrC* mutant was less competitive in the soft rot, the SirA and BarA mutants had no significant advantages or disadvantages. The BarA/SirA two-component system regulates motility through the *csr* regulatory mechanism (48).

The remarkable adaptability of non-typhoidal *Salmonella* spp. has likely contributed to their prominence among foodborne pathogens. Whether it is produce, meat, or poultry, there are few foods that are not susceptible to invasion by these pathogens. It is clear that non-typhoidal *Salmonella* spp. are well equipped to survive environments ranging from the harsh conditions in the phyllosphere to the acidic environments of tomatoes and macrophages. The work presented here sheds light on the intricate relationships that may occur throughout interspecies relationships and how non-typhoidal *Salmonella* spp. are able to effectively adapt to changing environments.

## MATERIALS AND METHODS

**Strain construction.** Deletion mutants were constructed using Datsenko–Wanner mutagenesis (76). Primers (Table 1) were designed to replace the entire open reading frame (ORF) (from the start to stop codons) with an *frt-kan-frt* cassette (76). Deletions were confirmed by PCR with the primers listed in Table 2. RIVET reporters were constructed by first removing a kanamycin resistance marker and then mating the plasmid pCE70 or pCE71 containing a *tnpR-lacZ* fusion into the mutant strain. The orientation of the insert was confirmed by PCR with primers upstream of the start site and downstream of the stop codon. Phage P22 grown on the *Salmonella* strain JS246 was then used to transduce a *res-tet-res* marker into the strain with a newly inserted *tnpR-lacZ*. The resulting strains were then purified using EGTA and screened on Evans blue-uranine (EBU) agar, as described previously (24).

**Bacterial culture and tomato infections.** *Salmonella* strains were grown overnight in a shaker at 37°C in Luria broth (LB) supplemented with kanamycin at 50 µg/ml (kan50) for mutants and LB supplemented with tetracycline at 10 µg/ml (tet10) for RIVET reporters. Wild-type *Salmonella enterica* serovar Typhimurium 14028 was grown without selection. *Pectobacterium carotovorum* SR38 and WPP14 *outS* mutants were grown overnight in 5 ml of LB broth in a shake incubator at 30°C.

**TABLE 1** Primers used in this study

Primer name	Sequence	Deletion primer
AG131	ATTGAGCAATACCGTCAGTCCGCGAAATAATCAGGAGTAATAAGAGCCTGTAGGCTGGAGCTGCTTCG	<i>carB</i> forward
AG132	ACATTATATTACAGGTCCGGTTAGAGCAATATCCGCCGGACCCCTTGTGCATATGAATATCCTCCTTAG	<i>carB</i> reverse
AG100	CATTCGTGCCAAAAGTGAATAAGTGTGAGCTACTTCAAAGTTGTGAGTGTAGGCTGGAGCTGCTTCG	<i>gntR</i> forward
AG101	TCCGCATGTCCGTGGTAAACTGGGCAAATCTATCCCTTTTATACCTTTTCATATGAATATCCTCCTTAG	<i>gntR</i> reverse
CEC202	TTCTGCAACGCAGGCAGCGTCAGCGTGTGGGTCATTGAGGACGTGTATGTAGGCTGGAGCTGCTTCG	<i>amyA</i> forward
CEC203.1	CTGCCGTAATTTTCGCTTCCCGGCAGCGCTCTGCCGCCGGGAAACGCTCACATATGAATATCCTCCTTAG	<i>amyA</i> reverse
CEC212	CAGTACGGCGACGATACGGTGTATGGTCTGTGGCGGGCCGCCGCTAATGTAGGCTGGAGCTGCTTCG	<i>malS</i> forward
CEC213.1	TTGTTTTGAAGGGGCTACCGGTACGCGAGGAGACCGGTAGCGCCACGACATATGAATATCCTCCTTAG	<i>malS</i> reverse

**Tomato infections.** For competitive fitness experiments, overnight cultures of a mutant and the wild-type strains were washed in phosphate-buffered saline (PBS) and diluted to  $\sim 10^4$  CFU/ml. These dilutions were combined in an approximately 1:1 ratio to prepare the inoculum. Three shallow wounds ( $\sim 1$  mm in diameter, 1 to 3 mm deep) were made in the epidermis of each green tomato. Inocula ( $3 \mu\text{l}$ ) containing approximately 10 to 100 CFU were injected, for a total of 30 to 300 CFU per tomato. In assays in which *Pectobacterium* spp. were added to the wounds, an additional  $3 \mu\text{l}$  of an undiluted but washed *Pectobacterium* suspension was inoculated into the tomatoes, as we have done before (24). *Salmonella* spp. were harvested after 3 days, as described before (24). Methods and data analyses were carried out

**TABLE 2** Strains and plasmid used in this study

Strain or plasmid	Genotype or description	Source, construction, or reference
Strains		
<i>Pectobacterium carotovorum</i>		
subsp. <i>carotovorum</i>		
SR38	Aggressive soft rot pathogen isolated from a shipment of Florida tomatoes	Bender et al. (77)
WPP14	<i>Pectobacterium carotovorum</i> subsp. <i>carotovorum</i> originally isolated from a diseased potato in Wisconsin	Gift from Amy Charkowski at University of Wisconsin-Madison
CCPcc 11	WPP14 <i>outS::frit-cam-frit</i>	This study
<i>Salmonella enterica</i> serovar Typhimurium		
14028	Wild type	American Type Culture Collection
BA3104	14028 <i>fljB::mudJ fljC::Tn10</i>	Iniguez et al. (78)
TIM145	14028 <i>flhC::mudJ</i>	Teplitski et al. (48)
JS246	14028 <i>yjeP::res1-tetRA-res1</i>	Datsenko and Wanner (76)
AT351	14028 <i>flhD::Tn10</i>	Teplitski et al. (48)
AT343	14028 <i>motA::Tn10</i>	Teplitski et al. (48)
RM6195	14028 <i>barA::kan</i>	Teplitski et al. (48)
TIM111	14028 <i>csrB::frit csrC::frit-kan</i>	Teplitski et al. (48)
BA746	14028 <i>sirA3::cam</i>	Iniguez et al. (78)
CA774	14028 <i>ackA-pta::kan</i>	Lawhon et al. (79)
AG51	14028 <i>carB::frit-kan-frit</i>	Made by Datsenko-Wanner mutagenesis using primers AG131 and AG132
KI3	14028 <i>gntR::frit-kan-frit</i>	Made by Datsenko-Wanner mutagenesis using primers AG100 and AG101
CEC6001	14028 <i>amyA::frit-kan-frit</i>	Made by Datsenko-Wanner mutagenesis using primers CEC202 and CEC203.1
CEC6003	14028 <i>malS::frit-kan-frit</i>	Made by Datsenko-Wanner mutagenesis using primers CEC212 and CEC213.1
CEC5001	JS246 <i>amyA::frit-kan-frit</i>	Made by Datsenko-Wanner mutagenesis using primers CEC201 and CEC203.1
CEC5003	JS246 <i>malS::frit-kan-frit</i>	Made by Datsenko-Wanner mutagenesis using primers CEC211 and CEC213.1
CEC8001	JS246 <i>amyA-frit-kan-frit</i>	Made by Datsenko-Wanner mutagenesis using primers CEC202 and CEC203.1
CEC8003	JS246 <i>malS-frit-kan-frit</i>	Made by Datsenko-Wanner mutagenesis using primers CEC212 and CEC213.1
MHM99	14028 <i>hisB::frit-kan-frit</i>	M. de Moraes, unpublished data
MHM73	14028 <i>trpC::frit-kan-frit</i>	de Moraes et al. (39)
MHM89	14028 <i>purH::frit-kan-frit</i>	de Moraes et al. (39)
MHM68	14028 <i>pyrB::frit-kan-frit</i>	de Moraes et al. (39)
Plasmid		
pKD4	FRT-kan-FRT template	Datsenko and Wanner (76)

as described before (37), with the addition that plates from tomatoes infected with *Pectobacterium* spp. were incubated at 42°C to reduce the growth of pectobacteria. For total growth experiments, inoculum and infection were performed as described above without the 1:1 ratio.

**Transposon insertion library construction, screening, and sequencing.** Construction of the MZ1597 library of Tn5 insertion mutants in *S. Typhimurium* 14028 using the Epicentre EZ Tn5<T7/Kan2> promoter insertion kit was described previously (39). The library was screened in green tomatoes inoculated with *S. Typhimurium* 14028 only, the *Salmonella* library and the wild-type *Pectobacterium carotovorum*, and the *Salmonella* library with an *outS* mutant of *P. carotovorum*. Prior to the inoculation, MZ1597 cultures were grown (with shaking at 250 rpm) for 16 h in LB broth supplemented with kanamycin at 37°C. Cultures of *P. carotovorum* were grown under the same conditions at 30°C. The cultures were pelleted, washed in PBS twice, and diluted 1:10, reaching a final density of approximately 10<sup>8</sup> CFU/ml. Three microliters of the suspension of MZ1597 was inoculated into three shallow (2 to 3 mm deep, 1 mm in diameter) wounds in tomato pericarps (~10<sup>6</sup> CFU per tomato); when added, *P. carotovorum* cultures were added in approximately 10-fold excess. Tomatoes were incubated at 22°C for 3 days until signs of the soft rot were fully visible in tomatoes inoculated with the wild-type *P. carotovorum*. *Salmonella* spp. were recovered by collecting ~1-g samples of the pericarp around the inoculation site, and samples from the same fruit were combined and homogenized in a stomacher (Sevrad). *Salmonella* cells were recovered by centrifugation and resuspended in 50 ml of LB broth followed by 6 h of growth at 37°C and 250 rpm, reaching ~10<sup>8</sup> CFU/ml. One milliliter of culture was recovered and used for library preparation.

**Barcode mapping.** Aliquots of around 5 × 10<sup>7</sup> CFU from input and output libraries were subjected to three washes in water, followed by proteinase K digestion, as described previously (39). After inactivation of the enzyme, a nested PCR regimen was performed to amplify the DNA regions adjacent to the barcode, as described before (39). The second PCR introduced standard dual 8-base indexes, which were unique to each sample. Samples were pooled and subjected to QIAquick PCR product purification (Qiagen), according to the manufacturer's recommendation. Illumina sequencing proceeded with custom primers Tn5\_EZ\_Right\_Seq\_fixed and Tn5\_EZ\_Index\_Seq\_new for a single indexed run with a read length of 25 bases. Barcode trimming, removal of duplicate reads using Picard tools, and mapping using Bowtie 2 were carried out as described previously (39). For the identification of barcoded mutants, the raw sequencing data consisted of single-end 25-bp reads. The first 18 bases, which represented the unique N18 tag for each Tn5 mutant, were extracted, and the abundances of all unique 18-mers were calculated using custom Perl scripts. The abundances of all N18 barcodes mapped within each annotated genome feature were summed in a strand-specific manner. This represented the aggregated abundance for each feature in the coding strand and the noncoding strand. The aggregated abundances for the input and output libraries were statistically analyzed using edgeR, and the log<sub>2</sub>-fold changes and FDRs were reported.

**Metabolic mapping and functional characterization.** Genes required for *Salmonella* survival in soft rot and intact tomatoes were retrieved from the TIA data set. An FDR of <0.05 and log<sub>2</sub>(fold change) of <0, FDR of <0.05 and log<sub>2</sub>(fold change) >0, and the intersection thereof were used in R studio to assign KEGG Orthology (KO) terms for *Salmonella enterica* serovar Typhimurium ATCC 14028 coding sequences, and the KEGG Mapper web interface was used to visualize metabolic pathways.

## SUPPLEMENTAL MATERIAL

Supplemental material for this article may be found at <https://doi.org/10.1128/AEM.01913-17>.

**SUPPLEMENTAL FILE 1**, PDF file, 1.0 MB.

## ACKNOWLEDGMENTS

We are thankful to Liuyi Bian and Michele Cabeza for technical assistance and Backyard Farms for supplying the tomatoes.

This research was funded by the Florida Education Fund Predoctoral fellowship program. This material is based upon work that is supported by the National Institute of Food and Agriculture, U.S. Department of Agriculture, under award no. 2017-67011-26064.

## REFERENCES

1. Teplitski M, Barak JD, Schneider KR. 2009. Human enteric pathogens in produce: un-answered ecological questions with direct implications for food safety. *Curr Opin Biotechnol* 20:166–171. <https://doi.org/10.1016/j.copbio.2009.03.002>.
2. Brandl MT. 2006. Fitness of human enteric pathogens on plants and implications for food safety. *Annu Rev Phytopathol* 44:367–392. <https://doi.org/10.1146/annurev.phyto.44.070505.143359>.
3. Brandl MT, Cox CE, Teplitski M. 2013. *Salmonella* interactions with plants and their associated microbiota. *Phytopathology* 103:316–325. <https://doi.org/10.1094/PHYTO-11-12-0295-RVW>.
4. Barak JD, Liang AS. 2008. Role of soil, crop debris, and a plant pathogen in *Salmonella enterica* contamination of tomato plants. *PLoS One* 3:e1657. <https://doi.org/10.1371/journal.pone.0001657>.
5. Kwan G, Charkowski A, Barak J. 2013. *Salmonella enterica* suppresses *Pectobacterium carotovorum* subsp. *carotovorum* population and soft rot progression by acidifying the microaerophilic environment. *mBio* 4:e00557-12. <https://doi.org/10.1128/mBio.00557-12>.
6. Wells JM, Butterfield JE. 1997. *Salmonella* contamination associated with bacterial soft rot of fresh fruits and vegetables in the marketplace. *Plant Dis* 81:867–872. <https://doi.org/10.1094/PDIS.1997.81.8.867>.

7. Goudeau DM, Parker CT, Zhou Y, Sela S, Kroupitski Y, Brandl MT. 2013. The *Salmonella* transcriptome in lettuce and cilantro soft rot reveals a niche overlap with the animal host intestine. *Appl Environ Microbiol* 79:250–262. <https://doi.org/10.1128/AEM.02290-12>.
8. Simko I, Zhou Y, Brandl MT. 2015. Downy mildew disease promotes the colonization of romaine lettuce by *Escherichia coli* O157:H7 and *Salmonella enterica*. *BMC Microbiol* 15:19. <https://doi.org/10.1186/s12866-015-0360-5>.
9. Yamazaki A, Li J, Hutchins WC, Wang L, Ma J, Ibekwe AM, Yang C-H. 2011. Commensal effect of pectate lyases secreted from *Dickeya dadantii* on proliferation of *Escherichia coli* O157:H7 edl933 on lettuce leaves. *Appl Environ Microbiol* 77:156–162. <https://doi.org/10.1128/AEM.01079-10>.
10. Noel JT, Joy J, Smith JN, Fatica M, Schneider KR, Ahmer BMM, Teplitski M. 2010. *Salmonella* SdiA recognizes *N*-acyl homoserine lactone signals from *Pectobacterium carotovorum* *in vitro*, but not in a bacterial soft rot. *Mol Plant Microbe Interact* 23:273–282. <https://doi.org/10.1094/MPMI-23-3-0273>.
11. Cox CE, McClelland M, Teplitski M. 2013. Consequences of disrupting *Salmonella* AI-2 signaling on interactions within soft rots. *Phytopathology* 103:352–361. <https://doi.org/10.1094/PHYTO-09-12-0237-FI>.
12. Marvasi M, Hochmuth GJ, Giurcanu MC, George AS, Noel JT, Bartz J, Teplitski M. 2013. Factors that affect proliferation of *Salmonella* in tomatoes post-harvest: the roles of seasonal effects, irrigation regime, crop and pathogen genotype. *PLoS One* 8:e80871. <https://doi.org/10.1371/journal.pone.0080871>.
13. Michael B, Smith JN, Swift S, Heffron F, Ahmer BMM. 2001. SdiA of *Salmonella enterica* is a LuxR homolog that detects mixed microbial communities. *J Bacteriol* 183:5733–5742. <https://doi.org/10.1128/JB.183.19.5733-5742.2001>.
14. Smith JN, Ahmer BMM. 2003. Detection of other microbial species by *Salmonella*: expression of the SdiA regulon. *J Bacteriol* 185:1357–1366. <https://doi.org/10.1128/JB.185.4.1357-1366.2003>.
15. Ahmer BMM. 2004. Cell-to-cell signalling in *Escherichia coli* and *Salmonella enterica*. *Mol Microbiol* 52:933–945. <https://doi.org/10.1111/j.1365-2958.2004.04054.x>.
16. Ahmer BMM, Smith JN, Dyszel JL, Lindsay A. 2007. Methods in cell-to-cell signaling in *Salmonella*. *Methods Mol Biol* 394:307–322. [https://doi.org/10.1007/978-1-59745-512-1\\_15](https://doi.org/10.1007/978-1-59745-512-1_15).
17. Abbott DW, Boraston AB. 2008. Structural biology of pectin degradation by Enterobacteriaceae. *Microbiol Mol Biol Rev* 72:301–316. <https://doi.org/10.1128/MMBR.00038-07>.
18. Barras F, van Gijsegem F, Chatterjee AK. 1994. Extracellular enzymes and pathogenesis of soft-rot *Erwinia*. *Annu Rev Phytopathol* 32:201–234. <https://doi.org/10.1146/annurev.py.32.090194.001221>.
19. Collmer A, Keen NT. 1986. The role of pectic enzymes in plant pathogenesis. *Annu Rev Phytopathol* 24:383–409. <https://doi.org/10.1146/annurev.py.24.090186.002123>.
20. Marquez-Villavicencio Mdel P, Weber B, Witherell RA, Willis DK, Charkowski AO. 2011. The 3-hydroxy-2-butanone pathway is required for *Pectobacterium carotovorum* pathogenesis. *PLoS One* 6:e22974. <https://doi.org/10.1371/journal.pone.0022974>.
21. Hugouvieux-Cotte-Pattat N, Condemine G, Nasser W, Reverchon S. 1996. Regulation of pectinolysis in *Erwinia chrysanthemi*. *Annu Rev Microbiol* 50:213–257. <https://doi.org/10.1146/annurev.micro.50.1.213>.
22. Brandl MT. 2008. Plant lesions promote the rapid multiplication of *Escherichia coli* O157:H7 on postharvest lettuce. *Appl Environ Microbiol* 74:5285–5289. <https://doi.org/10.1128/AEM.01073-08>.
23. Mole B, Habibi S, Dangel JL, Grant SR. 2010. Gluconate metabolism is required for virulence of the soft-rot pathogen *Pectobacterium carotovorum*. *Mol Plant Microbe Interact* 23:1335–1344. <https://doi.org/10.1094/MPMI-03-10-0067>.
24. George AS, González IS, Lorca GL, Teplitski M. 2016. Contribution of the *Salmonella enterica* KdgR regulon to persistence of the pathogen in vegetable soft rots. *Appl Environ Microbiol* 82:1353–1360. <https://doi.org/10.1128/AEM.03355-15>.
25. Shevchik VE, Robert-Baudouy J, Condemine G. 1997. Specific interaction between OutD, an *Erwinia chrysanthemi* outer membrane protein of the general secretory pathway, and secreted proteins. *EMBO J* 16:3007–3016. <https://doi.org/10.1093/emboj/16.11.3007>.
26. Shevchik VE, Condemine G. 1998. Functional characterization of the *Erwinia chrysanthemi* OutS protein, an element of a type II secretion system. *Microbiology* 144:3219–3228. <https://doi.org/10.1099/00221287-144-11-3219>.
27. Mikiciński A, Sobiczewski P, Sulikowska M, Puławska J, Treder J. 2010. Pectolytic bacteria associated with soft rot of Calla lily (*Zantedeschia* spp.) tubers. *J Phytopathol* 158:201–209. <https://doi.org/10.1111/j.1439-0434.2009.01597.x>.
28. Köiv V, Roosaare M, Vedler E, Kivistik PA, Toppi K, Schryer DW, Remm M, Tenson T, Mäe A. 2015. Microbial population dynamics in response to *Pectobacterium atrosepticum* infection in potato tubers. *Sci Rep* 5:11606. <https://doi.org/10.1038/srep11606>.
29. Raha M, Kawagishi I, Müller V, Kihara M, Macnab RM. 1992. *Escherichia coli* produces a cytoplasmic alpha-amylase, AmyA. *J Bacteriol* 174:6644–6652. <https://doi.org/10.1128/jb.174.20.6644-6652.1992>.
30. Garvey TC, Hewitt JD. 1991. Starch and sugar accumulation in two accessions of *Lycopersicon cheesmanii*. *Am Soc Hortic Sci* 116:77–79.
31. Wang F, Sanz A, Brenner ML, Smith A. 1993. Sucrose synthase, starch accumulation, and tomato fruit sink strength. *Plant Physiol* 101:321–327. <https://doi.org/10.1104/pp.101.1.321>.
32. Camilli D, Beattie D, Mekalanos J. 1994. Use of genetic recombination as a reporter of gene expression. *Proc Natl Acad Sci U S A* 91:2634–2638. <https://doi.org/10.1073/pnas.91.7.2634>.
33. Lawhon SD, Frye JG, Suyemoto M, Porwollik S, McClelland M, Altier C. 2003. Global regulation by CsrA in *Salmonella* Typhimurium. *Mol Microbiol* 48:1633–1645. <https://doi.org/10.1046/j.1365-2958.2003.03535.x>.
34. van Opijnen T, Bodi KL, Camilli A. 2009. Tn-seq: high-throughput parallel sequencing for fitness and genetic interaction studies in microorganisms. *Nat Methods* 6:767–772. <https://doi.org/10.1038/nmeth.1377>.
35. Khatiwara A, Jiang T, Sung S-S, Dawoud T, Kim JN, Bhattacharya D, Kim H-B, Ricke SC, Kwon YM. 2012. Genome scanning for conditionally essential genes in *Salmonella enterica* serotype Typhimurium. *Appl Environ Microbiol* 78:3098–3107. <https://doi.org/10.1128/AEM.06865-11>.
36. Parker CT, Kyle JL, Huynh S, Carter MQ, Brandl MT, Mandrell RE. 2012. Distinct transcriptional profiles and phenotypes exhibited by *Escherichia coli* O157:H7 isolates related to the 2006 spinach-associated outbreak. *Appl Environ Microbiol* 78:455–463. <https://doi.org/10.1128/AEM.06251-11>.
37. Noel JT, Arrach N, Alagely A, McClelland M, Teplitski M. 2010. Specific responses of *Salmonella enterica* to tomato varieties and fruit ripeness identified by *in vivo* expression technology. *PLoS One* 5:e12406. <https://doi.org/10.1371/journal.pone.0012406>.
38. Devroede N, Thia-Toong TL, Gigot D, Maes D, Charlier D. 2004. Purine and pyrimidine-specific repression of the *Escherichia coli* *carAB* operon are functionally and structurally coupled. *J Mol Biol* 336:25–42. <https://doi.org/10.1016/j.jmb.2003.12.024>.
39. de Moraes MH, Desai P, Porwollik S, Canals R, Perez DR, Chu W, McClelland M, Teplitski M. 2017. *Salmonella* persistence in tomatoes requires a distinct set of metabolic functions identified by transposon insertion sequencing. *Appl Environ Microbiol* 83:e03028-16. <https://doi.org/10.1128/AEM.03028-16>.
40. Kwan G, Pisithkul T, Amador-Noguez D, Barak J. 2015. *De novo* amino acid biosynthesis contributes to *Salmonella enterica* growth in alfalfa seedling exudates. *Appl Environ Microbiol* 81:861–873. <https://doi.org/10.1128/AEM.02985-14>.
41. Artz SW, Broach JR. 1975. Histidine regulation in *Salmonella* Typhimurium: an activator attenuator model of gene regulation. *Proc Natl Acad Sci U S A* 72:3453–3457. <https://doi.org/10.1073/pnas.72.9.3453>.
42. Carrari F, Baxter C, Usadel B, Urbanczyk-Wochniak E, Zanol M-I, Nunes-Nesi A, Nikiforova V, Centero D, Ratzka A, Pauly M, Sweetlove LJ, Fernie AR. 2006. Integrated analysis of metabolite and transcript levels reveals the metabolic shifts that underlie tomato fruit development and high-light regulatory aspects of metabolic network behavior. *Plant Physiol* 142:1380–1396. <https://doi.org/10.1104/pp.106.088534>.
43. Haiko J, Westerlund-Wikström B. 2013. The role of the bacterial flagellum in adhesion and virulence. *Biology (Basel)* 2:1242–1267. <https://doi.org/10.3390/biology2041242>.
44. Carsiotti M, Weinstein DL, Karch H, Holder IA, O'Brien AD. 1984. Flagella of *Salmonella* Typhimurium are a virulence factor in infected C57BL/6J mice. *Infect Immun* 46:814–818.
45. Stecher B, Barthel M, Schlumberger MC, Haberli L, Rabsch W, Kremer M, Hardt WD. 2008. Motility allows *S. Typhimurium* to benefit from the mucosal defence. *Cell Microbiol* 10:1166–1180. <https://doi.org/10.1111/j.1462-5822.2008.01118.x>.
46. Rivera-Chávez F, Winter SE, Lopez CA, Xavier MN, Winter MG, Nuccio SP, Russell JM, Laughlin RC, Lawhon SD, Sterzenbach T, Bevins CL, Tsolis RM, Harshey R, Adams LG, Bäuml AJ. 2013. *Salmonella* uses energy taxis to benefit from intestinal inflammation. *PLoS Pathog* 9:e1003267. <https://doi.org/10.1371/journal.ppat.1003267>.

47. Martínez LC, Martínez-Flores I, Salgado H, Fernández-Mora M, Medina-Rivera A, Puente JL, Collado-Vides J, Bustamante VH. 2014. *In silico* identification and experimental characterization of regulatory elements controlling the expression of the *Salmonella* *csrB* and *csrC* genes. *J Bacteriol* 196:325–336. <https://doi.org/10.1128/JB.00806-13>.
48. Teplitski M, Goodier RI, Ahmer BMM. 2003. Pathways leading from BarA/SirA to motility and virulence gene expression in *Salmonella*. *J Bacteriol* 185:7257–7265. <https://doi.org/10.1128/JB.185.24.7257-7265.2003>.
49. Romeo T. 1998. Global regulation by the small RNA-binding protein CsrA and the non-coding RNA molecule CsrB. *Mol Microbiol* 29:1321–1330. <https://doi.org/10.1046/j.1365-2958.1998.01021.x>.
50. Nishimura A, Hirota Y. 1989. A cell division regulatory mechanism controls the flagellar regulon in *Escherichia coli*. *Mol Gen Genet* 216:340–346. <https://doi.org/10.1007/BF00334374>.
51. Liu X, Matsumura P. 1994. The FlhD/FlhC complex, a transcriptional activator of the *Escherichia coli* flagellar class II operons. *J Bacteriol* 176:7345–7351. <https://doi.org/10.1128/jb.176.23.7345-7351.1994>.
52. Chilcott GS, Hughes KT. 2000. Coupling of flagellar gene expression to flagellar assembly in *Salmonella enterica* serovar Typhimurium and *Escherichia coli*. *Microbiol Mol Biol Rev* 64:694–708. <https://doi.org/10.1128/MMBR.64.4.694-708.2000>.
53. Wei BL, Brun-Zinkernagel A-M, Simecka JW, Prüß BM, Babitzke P, Romeo T. 2001. Positive regulation of motility and *flhDC* expression by the RNA-binding protein CsrA of *Escherichia coli*. *Mol Microbiol* 40:245–256. <https://doi.org/10.1046/j.1365-2958.2001.02380.x>.
54. Raffatellu M, George MD, Akiyama Y, Hornsby MJ, Nuccio SP, Paixao TA, Butler BP, Chu H, Santos RL, Berger T, Mak TW, Tsolis RM, Bevins CL, Solnick JV, Dandekar S, Bäuml AJ. 2009. Lipocalin-2 resistance confers an advantage to *Salmonella enterica* serotype Typhimurium for growth and survival in the inflamed intestine. *Cell Host Microbe* 5:476–486. <https://doi.org/10.1016/j.chom.2009.03.011>.
55. Kamada N, Chen G, Inohara N, Núñez G. 2013. Control of pathogens and pathobionts by the gut microbiota. *Nat Immunol* 14:685–690. <https://doi.org/10.1038/ni.2608>.
56. Teplitski M, Warriner K, Bartz J, Schneider KR. 2011. Untangling metabolic and communication networks: interactions of enterics with phyto-bacteria and their implications in produce safety. *Trends Microbiol* 19:121–127. <https://doi.org/10.1016/j.tim.2010.11.007>.
57. Hao L-Y, Willis DK, Andrews-Polymeris H, McClelland M, Barak JD. 2012. Requirement of siderophore biosynthesis for plant colonization by *Salmonella enterica*. *Appl Environ Microbiol* 78:4561–4570. <https://doi.org/10.1128/AEM.07867-11>.
58. Rivera-Chávez F, Lopez CA, Bäuml AJ. 2016. Oxygen as a driver of gut dysbiosis. *Free Radic Biol Med* 105:93–101. <https://doi.org/10.1016/j.freeradbiomed.2016.09.022>.
59. Rivera-Chávez F, Zhang LF, Faber F, Lopez CA, Byndloss MX, Olsan EE, Xu G, Velazquez EM, Lebrilla CB, Winter SE, Bäuml AJ. 2016. Depletion of butyrate-producing clostridia from the gut microbiota drives an aerobic luminal expansion of *Salmonella*. *Cell Host Microbe* 19:443–454. <https://doi.org/10.1016/j.chom.2016.03.004>.
60. Liao CH. 2008. Growth of *Salmonella* on sprouting alfalfa seeds as affected by the inoculum size, native microbial load and *Pseudomonas fluorescens* 2-79. *Lett Appl Microbiol* 46:232–236. <https://doi.org/10.1111/j.1472-765X.2007.02302.x>.
61. Janisiewicz WJ, Conway WS, Leverenz B. 1999. Biological control of postharvest decays of apple can prevent growth of *Escherichia coli* O157:H7 in apple wounds. *J Food Prot* 62:1372–1375. <https://doi.org/10.4315/0362-028X-62.12.1372>.
62. Wells JM, Butterfield JE. 1999. Incidence of *Salmonella* on fresh fruits and vegetables affected by fungal rots or physical injury. *Plant Dis* 83:722–726. <https://doi.org/10.1094/PDIS.1999.83.8.722>.
63. Wilson M, Lindow SE. 1994. Coexistence among epiphytic bacterial populations mediated through nutritional resource partitioning. *Appl Environ Microbiol* 60:4468–4477.
64. Zelezniak A, Andrejev S, Ponomarova O, Mende DR, Bork P, Patil KR. 2015. Metabolic dependencies drive species co-occurrence in diverse microbial communities. *Proc Natl Acad Sci U S A* 2015:6449–6454. <https://doi.org/10.1073/pnas.1421834112>.
65. O'Callaghan D, Maskell D, Liew FY, Easmon CSF, Dougan G. 1988. Characterization of aromatic- and purine-dependent *Salmonella* Typhimurium: attenuation, persistence, and ability to induce protective immunity in BALB/c mice. *Infect Immun* 56:419–423.
66. Carnell SC, Bowen A, Morgan E, Maskell DJ, Wallis TS, Stevens MP. 2007. Role in virulence and protective efficacy in pigs of *Salmonella enterica* serovar Typhimurium secreted components identified by signature-tagged mutagenesis. *Microbiology* 153:1940–1952. <https://doi.org/10.1099/mic.0.2006/006726-0>.
67. Raushel FM, Thoden JB, Holden HM. 1999. The amidotransferase family of enzymes: molecular machines for the production and delivery of ammonia. *Biochemistry* 38:7891–7899. <https://doi.org/10.1021/bi990871p>.
68. Zhuo T, Rou W, Song X, Guo J, Fan X, Kamau GG, Zou H. 2015. Molecular study on the *carAB* operon reveals that *carB* gene is required for swimming and biofilm formation in *Xanthomonas citri* subsp. *citri*. *BMC Microbiol* 15:225. <https://doi.org/10.1186/s12866-015-0555-9>.
69. Kortman GA, Raffatellu M, Swinkels DW, Tjalsma H. 2015. Nutritional iron turned inside out: intestinal stress from a gut microbial perspective. *FEMS Microbiol Rev* 38:1202–1234. <https://doi.org/10.1111/1574-6976.12086>.
70. Eriksson S, Lucchini S, Thompson A, Rhen M, Hinton JCD. 2003. Unravelling the biology of macrophage infection by gene expression profiling of intracellular *Salmonella enterica*. *Mol Microbiol* 47:103–118. <https://doi.org/10.1046/j.1365-2958.2003.03313.x>.
71. Pontes MH, Lee E-J, Choi J, Groisman EA. 2015. *Salmonella* promotes virulence by repressing cellulose production. *Proc Natl Acad Sci U S A* 112:5183–5188. <https://doi.org/10.1073/pnas.1500989112>.
72. Prüß BM, Campbell JW, Van Dyk TK, Zhu C, Kogan Y, Matsumura P. 2003. FlhD/FlhC is a regulator of anaerobic respiration and the Entner-Doudoroff pathway through induction of the methyl-accepting chemotaxis protein Aer. *J Bacteriol* 185:534–543. <https://doi.org/10.1128/JB.185.2.534-543.2003>.
73. Prüß BM, Liu X, Hendrickson W, Matsumura P. 2001. FlhD/FlhC-regulated promoters analyzed by gene array and *lacZ* gene fusions. *FEMS Microbiol Lett* 197:91–97. <https://doi.org/10.1111/j.1574-6968.2001.tb10588.x>.
74. Prüß BM, Matsumura P. 1996. A regulator of the flagellar regulon of *Escherichia coli*, FlhD, also affects cell division. *J Bacteriol* 178:668–674. <https://doi.org/10.1128/jb.178.3.668-674.1996>.
75. Liu MY, Gui G, Wei B, Preston JF, III, Oakford L, Yüksel Ü, Giedroc DP, Romeo T. 1997. The RNA molecule CsrB binds to the global regulatory protein CsrA and antagonizes its activity in *Escherichia coli*. *J Biol Chem* 272:17502–17510. <https://doi.org/10.1074/jbc.272.28.17502>.
76. Datsenko KA, Wanner BL. 2000. One-step inactivation of chromosomal genes in *Escherichia coli* K-12 using PCR products. *Proc Natl Acad Sci U S A* 97:6640–6645. <https://doi.org/10.1073/pnas.120163297>.
77. Bender RJ, Sargent SA, Brecht JK, Bartz JA. 1992. Effect of tomato grade on incidence of decay during simulated shipping. *Proc Fla State Hort Soc* 105:119–121.
78. Iniguez AL, Dong Y, Carter HD, Ahmer BMM, Stone JM, Triplett EW. 2005. Regulation of enteric endophytic bacterial colonization by plant defenses. *Mol Plant Microbe Interact* 18:169–178. <https://doi.org/10.1094/MPMI-18-0169>.
79. Lawhon SD, Maurer R, Suyemoto M, Altier C. 2002. Intestinal short-chain fatty acids alter *Salmonella typhimurium* invasion gene expression and virulence through BarA/SirA. *Mol Microbiol* 46:1451–1464. <https://doi.org/10.1046/j.1365-2958.2002.03268.x>.