

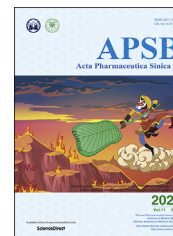

Chinese Pharmaceutical Association  
Institute of Materia Medica, Chinese Academy of Medical Sciences

Acta Pharmaceutica Sinica B

[www.elsevier.com/locate/apsb](http://www.elsevier.com/locate/apsb)  
[www.sciencedirect.com](http://www.sciencedirect.com)



## REVIEW

# Regulatory control of the Na–Cl co-transporter NCC and its therapeutic potential for hypertension



Nur Farah Meor Azlan, Maarten P. Koeners, Jinwei Zhang\*

*Institute of Biomedical and Clinical Sciences, Medical School, College of Medicine and Health, University of Exeter, Hatherly Laboratories, Exeter EX4 4PS, UK*

Received 24 May 2020; received in revised form 28 August 2020; accepted 31 August 2020

### KEY WORDS

NaCl-cotransporter NCC;  
Cardiovascular disease;  
CUL3/KLHL3-WNK-  
SPAK/OSR1;  
Blood pressure regulation;  
Kinase inhibitors;  
Membrane trafficking;  
Therapeutic targets;  
Hypertension

**Abstract** Hypertension is the largest risk factor for cardiovascular disease, the leading cause of mortality worldwide. As blood pressure regulation is influenced by multiple physiological systems, hypertension cannot be attributed to a single identifiable etiology. Three decades of research into Mendelian forms of hypertension implicated alterations in the renal tubular sodium handling, particularly the distal convoluted tubule (DCT)-native, thiazide-sensitive Na–Cl cotransporter (NCC). Altered functions of the NCC have shown to have profound effects on blood pressure regulation as illustrated by the over activation and inactivation of the NCC in Gordon's and Gitelman syndromes respectively. Substantial progress has uncovered multiple factors that affect the expression and activity of the NCC. In particular, NCC activity is controlled by phosphorylation/dephosphorylation, and NCC expression is facilitated by glycosylation and negatively regulated by ubiquitination. Studies have even found parvalbumin to be an unexpected regulator of the NCC. In recent years, there have been considerable advances in our understanding of NCC control mechanisms, particularly *via* the pathway containing the with-no-lysine [K] (WNK) and its downstream target kinases, SPS/Ste20-related proline-alanine-rich kinase (SPAK) and oxidative stress

*Abbreviations:* ATP, adenosine triphosphate; Ca<sup>2+</sup>, calcium ion; CCC, cation-coupled chloride cotransporters; CCT, conserved carboxy-terminal; CNI, calcineurin inhibitors; CUL3, cullin 3; DAG, diacylglycerol; DCT, distal convoluted tubule; DUSP, dual specificity phosphatases; ECF, extracellular fluid; ELISA, enzyme-bound immunosorbent analysis; ENaC, epithelial sodium channels; ERK, extracellular signal-regulated kinases; GABA, gamma-aminobutyric acid; HEK293, human embryonic kidney 293; I1, inhibitor 1; K<sup>+</sup>, potassium ion; KCC, potassium-chloride-cotransporters; KLHL3, kelch-like 3; KS-WNK1, kidney specific-WNK1; MAPK, mitogen-activated protein kinase; mDCT, mammalian DCT; MO25, mouse protein-25; mRNA, messenger RNA; Na<sup>+</sup>, sodium ion; NaCl, sodium chloride; NCC, sodium–chloride cotransporters; NKCC, sodium–potassium–chloride-cotransporter; OSR1, oxidative stress-responsive gene 1; PCT, proximal convoluted tubule; PHAI1, pseudohypoaldosteronism type II; PP, protein phosphatase; PV, parvalbumin; RasGRP1, RAS guanyl-releasing protein 1; ROMK, renal outer medullary potassium; SLC12, solute carrier 12; SPAK, Ste20-related proline-alanine-rich kinase; TAL, thick ascending limb; WNK, with-no-lysine kinases.

\*Corresponding author.

E-mail address: [j.zhang5@exeter.ac.uk](mailto:j.zhang5@exeter.ac.uk) (Jinwei Zhang).

Peer review under responsibility of Chinese Pharmaceutical Association and Institute of Materia Medica, Chinese Academy of Medical Sciences.

<https://doi.org/10.1016/j.apsb.2020.09.009>

2211-3835 © 2021 Chinese Pharmaceutical Association and Institute of Materia Medica, Chinese Academy of Medical Sciences. Production and hosting by Elsevier B.V. This is an open access article under the CC BY-NC-ND license (<http://creativecommons.org/licenses/by-nc-nd/4.0/>).

responsive 1 (OSR1), which has led to the discovery of novel inhibitory molecules. This review summarizes the currently reported regulatory mechanisms of the NCC and discusses their potential as therapeutic targets for treating hypertension.

© 2021 Chinese Pharmaceutical Association and Institute of Materia Medica, Chinese Academy of Medical Sciences. Production and hosting by Elsevier B.V. This is an open access article under the CC BY-NC-ND license (<http://creativecommons.org/licenses/by-nc-nd/4.0/>).

## 1. Renal sodium handling and hypertension

The renal system plays a critical role in the homeostasis of blood pressure. One of the ways this role is accomplished is through the maintenance of electrolyte balance in the extracellular fluid (ECF) whereby electrolyte intake is equalized with electrolyte excretion by the kidneys. As sodium ( $\text{Na}^+$ ) is the main ionic constituent of the ECF,  $\text{Na}^+$  reabsorption in the kidney is tightly coupled to obligatory water reabsorption. Thus, a disturbance in  $\text{Na}^+$  reabsorption provokes abnormal water retention or loss. Water retention in particular, increases blood pressure due to ECF volume expansion which places considerable strain on the blood vessels leaving the kidneys<sup>1</sup>. Consistent high blood pressure or hypertension is a major risk factor for many cardiovascular diseases<sup>2</sup>.

The functional unit of the kidney, the nephron, is divided into two segments: (i) the renal corpuscle for which blood plasma is filtered and (ii) the renal tubule where substances are reabsorbed. Of the 99% of  $\text{Na}^+$  reabsorbed along various parts of the renal tubule, 50%–60% is reabsorbed by the proximal convoluted tubule (PCT), 20%–30% is reabsorbed by the thick ascending limb (TAL), and 5%–10% by the distal convoluted tubule (DCT). Although a huge portion of  $\text{Na}^+$  is reabsorbed in the PCT, high salt ( $\text{NaCl}$ ) intake is usually offset by decreased  $\text{Na}^+$  reabsorption in the DCT as it is uniquely capable of adapting to changes in hormonal stimuli<sup>3</sup>. The importance of the DCT is further supported by insights gained from genetic disorders of hypertension that revealed a close association between  $\text{Na}^+$  handling in the DCT and blood pressure regulation.

## 2. Na–Cl cotransporter (NCC) and the *SLC12* gene family

The solute carrier 12 (*SLC12*) gene family encodes for the electroneutral cation-coupled chloride cotransporters (CCCs) family of membrane proteins. Genes within the family are highly homologous and are further divided into subfamilies of chloride translocation either with  $\text{Na}^+$  or potassium ( $\text{K}^+$ ) in a 1:1 stoichiometry<sup>4</sup>. The  $\text{Na}^+$  driven family consists of NCC and two isoforms of sodium–potassium–chloride cotransporter (NKCCs): NKCC1 and NKCC2. The  $\text{K}^+$  driven family of potassium–chloride cotransporters (KCCs) is made up of KCC1–KCC4. Two additional proteins, CCC6 and CCC9, are uncharacterized thus far. Although all members of the *SLC12* family are regulated by kinase-induced phosphorylation and phosphatase-induced dephosphorylation at key serine/threonine residues, phosphorylation has the opposite effects on the two subfamilies<sup>5</sup>. Phosphorylation activates the  $\text{Na}^+$ -dependent branches and inactivates the  $\text{Na}^+$ -independent branch.

Genetic mutations in genes that encode for the  $\text{Na}^+$  driven family revealed the importance of this subfamily in blood pressure regulation. NKCC2 is kidney-specific and is the major salt

transport pathway in the TAL (Fig. 1). Inhibition of NKCC2 by loop diuretics impairs  $\text{Na}^+$  reabsorption, ultimately decreasing blood pressure<sup>6</sup>. Loss-of-function mutations in the *SLC12A1* gene that encodes for NKCC2, such as c.1833 deletion, cause type 1 Bartter syndrome, a disorder characterised by hypokalaemia, alkalosis along with normal-to hypotension<sup>7</sup>. Contrarily, although NKCC1 is widely distributed, its blood pressure regulating effects remain poorly understood. NCC is exclusively expressed in the DCT and is the site of one of the most effective antihypertensive, thiazide diuretics<sup>8,9</sup>. As the NCC is important for fine-tuning of salt homeostasis, altered functions of the NCC have profound effects on blood pressure regulation. Gitelman syndrome, a loss of NCC function, is characterised by salt loss and hypotension. Gain-of-function mutations in genes encoding for the regulators of NCC lead to the clinical inverse of Gitelman, Gordon's syndrome [also known as pseudohypoaldosteronism type II (PHAII)], a disorder characterised by salt retention and hypertension<sup>10</sup>.

## 3. Regulation of the NCC

The distal nephron has a central role in blood pressure regulation<sup>1</sup>. This role is accomplished through maintenance of  $\text{Na}^+$  balance in the ECF. Although the majority of  $\text{Na}^+$  is reabsorbed in the proximal nephron, the distinctive capability of the DCT to respond to changes in hormonal stimuli means that it is responsible for fine-tuning of  $\text{Na}^+$  homeostasis in the ECF<sup>3</sup>. Amongst the  $\text{Na}^+$  transporters in the distal nephron, the effects of mutations in NCC, a salt transporter exclusively expressed in the DCT, and its regulators on the ECF, illustrates the importance of the NCC in blood pressure regulation.

NCC is functional in a homodimeric form and is glycosylated for efficient function and surface expression<sup>11</sup>. Like all the other *SLC12* family of cotransporters, NCC activity is regulated by phosphorylation/dephosphorylation at key serine/threonine residues. However, unlike the  $\text{K}^+$  driven family of *SLC12* cotransporters, phosphorylation activates the NCC and dephosphorylation halts their activity. Ubiquitination and consequent endocytosis of NCC downregulates NCC surface expression<sup>12</sup>.

### 3.1. Phosphorylation by WNK-SPAK/OSR1 kinases: master regulator of the NCC

Phosphorylation at key serine/threonine sites (Thr46, Thr55 and Thr60) triggers the activation of the NCC and inhibits the ubiquitination and subsequent endocytosis of NCC. With-no-lysine kinases (WNKs) are serine–threonine kinases that are characterized by the atypical placement of their catalytic lysine residue<sup>13</sup>. WNKs modulate the *SLC12* family of CCCs for transport between cells. Their primary target is the NCC (Fig. 2). Two isoforms of the WNK family (WNK1–4), WNK1 and WNK4, are expressed

in the mammalian DCT. However, the predominant isoform in the DCT is a kidney-specific short isoform of WNK1, kidney specific-WNK1 (KS-WNK1), which lacks a kinase domain. Although the physiological role of KS-WNK1 remains elusive, recent evidence suggests it has a positive effect on the WNK signaling<sup>14</sup>. In 2001, mutations in the genes that encode for WNK1 and WNK4 were discovered to cause Gordon's syndrome<sup>10,15,16</sup>. Mutations in the *WNK1* gene are intronic deletions that lead to the ectopic expression of full-length WNK1, an isoform that is expressed at low levels in the DCT. Mouse models overexpressing WNK1 displayed enhanced phosphorylation of NCC<sup>10,17</sup>. Increased phosphorylation and thus activation of NCC allows for more  $\text{Na}^+$  reabsorption, consequently raising blood pressure. The link was observed in animal models that carry mutated WNK4, which demonstrated increased phosphorylated NCC levels and produced Gordon's-like phenotype. *Wnk4* deficient mice displayed reduced NCC phosphorylation and hypotension similar to that of Gitelman phenotype<sup>18,19</sup>. These studies provided insight into the pathological mechanisms underlying hypertensive-causing WNK mutations, demonstrating an essential role for WNK in the kidney.

The molecular mechanism by which WNKs regulate blood pressure was discovered when it was reported that WNKs bind and phosphorylate both Ste20-related proline–alanine-rich kinase (SPAK) and oxidative stress-responsive gene 1 (OSR1) thus inducing their activation<sup>20–23</sup>. Furthermore, mice with defected SPAK and OSR1 had reduced baseline blood pressure significantly<sup>24–28</sup>. Increased phosphorylated NCC was observed in cells overexpressing SPAK<sup>29</sup>. Based on their interactions with WNKs and NCCs, it is believed that WNK regulates the NCC through SPAK/OSR1 (Fig. 2). Further analyses found that upon activation, SPAK and OSR1 subsequently bind mouse protein-25 (MO25), a scaffolding protein which significantly enhances their basal activity by 80- to 100-fold, respectively<sup>30</sup>. Active SPAK and OSR1 in complex with MO25 phosphorylate a selection of cotransporters including NCC at different residues: Thr45/46/50/55/60 and Ser71/73/91. Such

phosphorylation influences movement of salt through the NCC, ensuing changes in electrolyte balance which ultimately translate into changes in blood pressure. Phosphorylation of NCC enhances transport activity at the plasma membrane and also prevents NCC ubiquitination and consequent endocytosis<sup>31,32</sup>. Polymorphisms in the SPAK<sup>33,34</sup>, WNK1<sup>35–38</sup> and WNK4<sup>39</sup> have been linked to human hypertension.

More recent investigations reveal multiple physiological regulators of NCC such as dietary  $\text{K}^+$  intake, insulin and more. However, these electrolyte and hormonal stimuli are increasingly associated with the WNK–SPAK/OSR1 signaling pathway<sup>40–44</sup>. Notably, although aldosterone was previously thought to directly upregulate NCC, aldosterone has been shown to indirectly regulate the WNK–SPAK/OSR1 pathway and by extension, the NCC *via* modulation of plasma potassium levels<sup>42,45,46</sup>. Less extensively studied but recognized WNK–SPAK/OSR1-dependent hormonal manipulators of NCC are insulin, norepinephrine and angiotensin II<sup>47</sup>. A more detailed account of the modulators of the WNK–SPAK pathway can be found in recent reviews by Wu et al.<sup>12</sup> and Furusho et al.<sup>48</sup>. Taken together, these investigations support the role of WNK–SPAK/OSR1 as the master activator of the NCC.

### 3.2. Dephosphorylation by PP3/PP4: the counter-regulatory system

Although much work has been focused on phosphorylation induced activation of NCC, it has been reported that dephosphorylation of NCC involving the serine–threonine protein phosphatase (PP)-3 or calcineurin, along with PP1 and PP4, can counterbalance the kinases acting on the NCC (Fig. 2). Studies by Glover et al.<sup>49</sup> and Gamba et al.<sup>50</sup> using the *Xenopus oocyte* system, observed PP4 inhibition of NCC activity in a phosphatase-dependent manner, suggesting that phosphatases may inhibit NCC. Similarly, experiments with pharmacological inhibitors

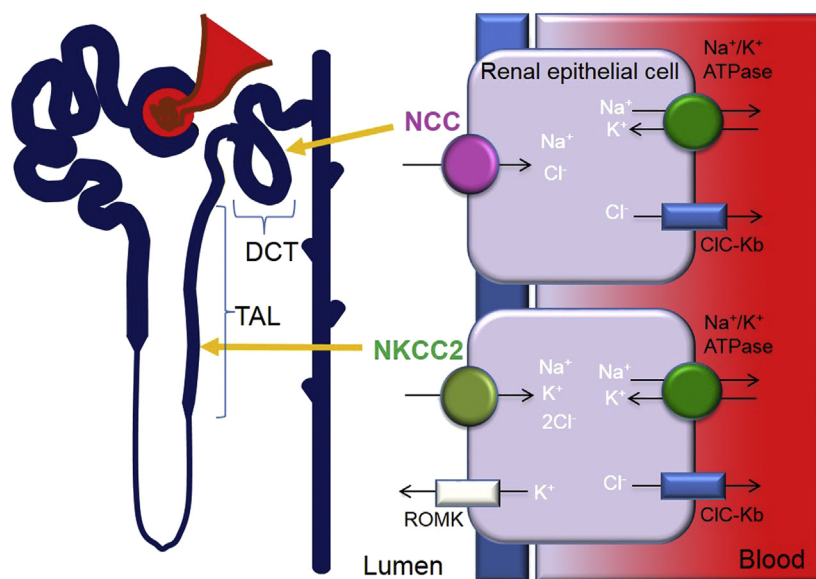

**Figure 1** Sodium handling in the distal nephron. The thick ascending limb (TAL) is a region responsible for 20%–30% of sodium ( $\text{Na}^+$ ) reabsorption. The predominant mechanism of transport in the TAL is the Na–K–Cl cotransporter 2 (NKCC2). The distal convoluted tubule (DCT) is responsible for 5%–10% of  $\text{Na}^+$  reabsorption. The major  $\text{Na}^+$  transport in the DCT is the Na–Cl co-transporter (NCC). Other ion transport mechanisms include the renal outer medullary potassium channel (ROMK), the sodium potassium pump ( $\text{Na}^+/\text{K}^+$  ATPase) and the chloride channel Kb (ClC-Kb).

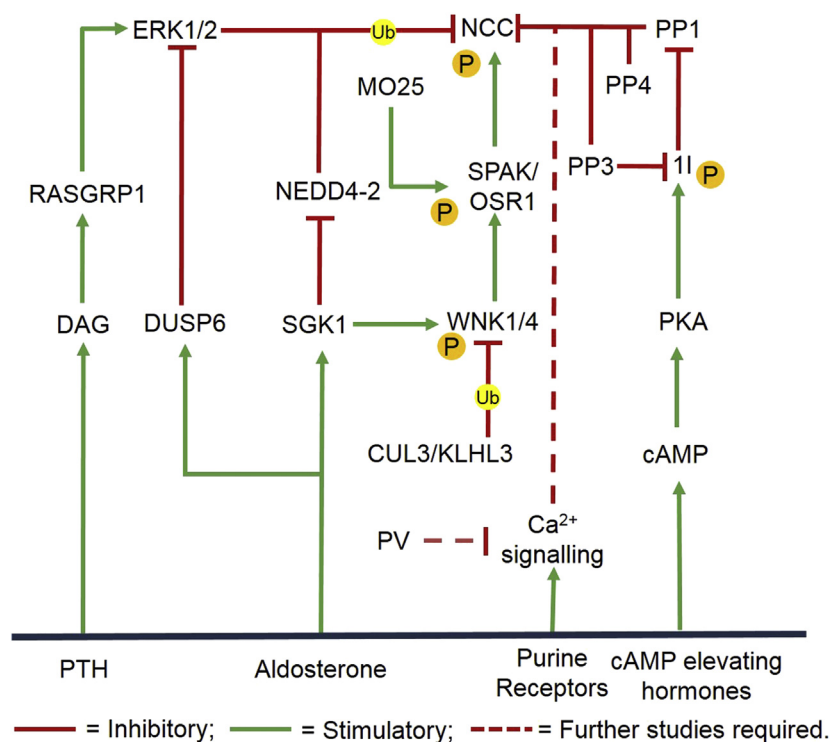

**Figure 2** Proposed integrated model of NCC regulation. The  $\text{Na}^+\text{-Cl}^-$  co-transporter (NCC) is the principal salt absorptive pathway in the distal convoluted tubule (DCT). The NCC is activated by kinase-induced phosphorylation (P) via the with-no-lysine [K] (WNK) and its downstream target kinases, SPS/Ste20-related proline–alanine-rich kinase (SPAK) and oxidative stress responsive (OSR) and deactivated by phosphatase-induced dephosphorylation via protein phosphatase 1-3-4 (PP1-3-4). Activation of SPAK is enhanced via attachment of the mouse protein-25 (MO25). The expression of NCC is directly regulated via ubiquitination and subsequent endocytosis of NCC via the RAS guanyl nucleotide-releasing protein (RasGRP) and its downstream target extracellular signal-regulated protein kinase (ERK) 1/2 or indirectly via ubiquitination and suppression of WNK by the cullin3 (CUL3)/kelch-like-3 (KLHL3) ubiquitin ligase complex. ERK1/2 is inhibited by DUSP6 and the phosphatases are inhibited by an endogenous inhibitor 1 (I1). Further studies are required to evaluate the NCC regulatory effects of parvalbumin (PV) via modulations of the ATP-induced  $\text{Ca}^{2+}$  signalling. The modulators of these regulatory events include parathyroid hormone (PTH), aldosterone, purine receptors and cAMP elevating hormones.

further support the counter-regulatory mechanisms of phosphatases on NCC. Calcineurin inhibitors (CNI) are used as anti-rejection drugs in transplant patients<sup>51</sup>. The common side effects of CNIs resemble the cardinal features of Gordon's syndrome, potentially due to its effect on the NCC. Indeed, administration of two CNIs, tacrolimus<sup>52</sup> and cyclosporine<sup>53</sup>, has been shown to increase phosphorylation and activation of NCC. Inhibition of the phosphatase calcineurin and the consequent inhibition of NCC dephosphorylation is a likely mechanism to counterbalance the phosphorylation activity of the WNK kinases. This is supported by recent studies that observed a rise in blood pressure in wild-type mice treated with tacrolimus in comparison to NCC-knockout mice, emphasized by exaggerated effects in mice overexpressing NCC<sup>54</sup>. The addition of hydrochlorothiazide, reversed the tacrolimus-induced hypertension in the mice<sup>54</sup>. These findings are consistent in patients as immunohistochemistry of transplant biopsies from kidney donor recipients revealed a pronounced increase in total and phosphorylated NCCs of those treated with tacrolimus when compared to the control group<sup>54</sup>.

Consistent with the regulatory role of phosphatase in NCC activity, treatment with the pharmacological inhibitor of PP1, calyculin A has been observed to enhance NCC phosphorylation<sup>55</sup>. Coincidentally, the endogenous PP1 inhibitor, inhibitor 1 (I1), is expressed in the DCT and has been demonstrated to

promote NCC activity<sup>55</sup>. Observations of phosphorylation and activation of I1 by cAMP-dependent PKA, coupled with increased phosphorylated NCC observed with cAMP elevating hormones (PTH and  $\beta$ -adrenergic agonists), suggests a link between PP1 phosphatase activity and NCC (Fig. 2). I1 knockout mice exhibited decreased levels of phosphorylated NCC<sup>56</sup>. Studies on the regulation of the NKCC1 found that PP1 binds directly to the N-terminal tail of NKCC1 in direct proximity to SPAK and that direct dephosphorylation is only 1 of 3 PP1 activities on NKCC1 regulation. Other inhibitory activities of PP1 on NKCC1 activity include dephosphorylation of SPAK and another undefined mechanism independent of its catalytic activity<sup>57</sup>. Although NCC lacks the acidic motif of the facilitated NKCC1 binding to PP1, *in vitro* assays revealed that PP1 directly interacts with and dephosphorylates NCC<sup>55</sup>. However, recent studies link PP1 to the WNK–SPAK/OSR1 pathway through modulation of WNK4 and SPAK phosphorylation despite the lack of a significant involvement of I1 in SPAK/OSR1 regulation<sup>58</sup>. These findings do not preclude the indirect control of NCC by phosphates via the WNK–SPAK/OSR1 pathway. However, as the study specifically investigated the role of PP1 on WNK4 inhibition of the renal outer medullary potassium (ROMK) channel, a channel that is inversely regulated by WNK4 in comparison to NCC, further research is

needed to explore possible indirect effect of PP1 through WNK4. Although additional work will be necessary to determine the mechanism of phosphatase action, the current findings suggest that phosphatases may inhibit NCC activity directly through dephosphorylation and inactivation of the NCC.

### 3.3. Ubiquitination by RasGRP1/NEDD4-2/KLHL3/CUL3: negative regulation of NCC

Early studies reported that functional NCC is expressed in a glycosylated homodimeric form on the plasma membrane or in subapical vesicles<sup>59,60</sup>. However, very little is known of the regulatory mechanisms that govern the membrane expression of NCC<sup>61</sup>. Extracellular signal-regulated kinases (ERK1/2) mitogen-activated protein kinase (MAPK) is an established modulator of other ion transporters expression such as ROMK and epithelial sodium channels (ENaC) through ubiquitination and subsequent degradation<sup>62,63</sup>. A study was conducted by Ko and colleagues<sup>64</sup> to assess if ubiquitination of NCC is regulated by ERK1/2 MAPK signaling pathway, or if there is a potential role of ERK1/2 MAPK in NCC surface expression. Utilizing heterologous mammalian expression, the study reported a reduction in cells and NCC surface expression *via* ubiquitination by ERK1/2. Ubiquitination by ERK1/2 led to endocytosis and decreased NCC activity (Fig. 2). This process could be disabled by inhibition of ubiquitin-activating enzyme E1 with UBEI-41<sup>64</sup>. Further studies revealed that ERK1/2 MAPK activation is dependent on phosphorylation by RAS guanyl-releasing protein 1 (RasGRP1). RasGRP1 is directly activated by diacylglycerol (DAG). Treatment with phorbol ester, an analog of DAG, showed reduced NCC membrane activation and a rise in internalized NCC<sup>65</sup>. Concurrently, studies using the *Xenopus laevis* oocytes as expression systems revealed that WNK4 reduces NCC abundance on the plasma membrane<sup>66</sup>. Overexpression of WNK4 in COS-7 cells also demonstrated reduced NCC surface protein expression *via* enhanced degradation through a lysosomal pathway<sup>67–69</sup>. Although SPAK/OSR1 is downstream effectors of WNKs, WNK4 modulation of NCC expression has been revealed to occur *via* activation of the ERK1/2 MAPK signaling pathway<sup>68–70</sup>. A study by Zhou and colleagues<sup>70</sup> demonstrated that WNK4 enhanced phosphorylation of ERK1/2 signaling in a dose-dependent manner and that knockdown of WNK4 reduced ERK1/2 phosphorylation and raised the total endogenous expression of NCC in mDCT cells. Other modulators confirmed to regulate NCC *via* the RasGRP1–ERK1/2 MAPK pathway are the parathyroid hormones<sup>71,72</sup>. Dual specificity phosphatases (DUSP), inhibitor of ERK1/2, decrease ubiquitination of NCC, consequently increasing NCC abundance<sup>73</sup>. As mentioned in previous sections and noted by Rosanbaek and other teams<sup>31</sup>, the levels of NCC phosphorylation and ubiquitination are linked despite their contrasting roles in NCC plasma membrane level modulation. A greater plasma level of NCC is seen with increased levels of phosphorylated NCC and reduced plasma membrane levels of ubiquitinated NCC correlated to decreased NCC endocytosis<sup>31,74,75</sup>. The ubiquitin–protein ligase, NEDD4-2, is implicated in NCC ubiquitination and consequent suppression. Modulation of NEDD4-2 *in vitro* and *in vivo* reduces NCC abundance and expression on the membrane<sup>76–78</sup>. NEDD4-2 knockout mice possessed features akin to Gordon's syndrome and an amplification of NCC phosphorylation. Although NCC co-immunoprecipitated with NEDD4-2<sup>78</sup>, the effect of NEDD4-2 was eliminated by WNK3<sup>79</sup>. Thus further research is needed to further elucidate the influence or absence of WNK kinases on the NCC endocytic pathway.

The WNK–SPAK/OSR1–NCC pathway has been shown to be downregulated *via* degradation by the cullin 3 (CUL3)–kelch-like 3 (KLHL3) E3 ubiquitin ligase complex (Fig. 2). KLHL3 and CUL3 make up the E3 ubiquitin ligase complex that targets their substrate proteins for proteasome degradation *via* attachment of ubiquitinous moieties<sup>80</sup>. WNKs are substrates of the KLHL3–CUL3 ligase complex<sup>81–83</sup>. Upon binding to the ligase complex, WNKs are ubiquitinated. The ubiquitinated WNK is then targeted for degradation *via* the ubiquitin–proteasome system. In 2012, mutations in CUL3 and KLHL3 were identified in families with Gordon's syndrome. Mutations of KLHL3 impair its bindings to WNK and CUL3 and mutations of CUL3 lead to enhanced ubiquitin ligase activity and the subsequent degradation of KLHL3<sup>84,85</sup>. These mutations consequently reduce WNK degradation leading to the accumulation of NCC. Overall, these studies establish a compelling rationale for the importance of ubiquitination for the direct regulation of NCC *via* the RasGRP1–ERK1/2 pathway and NEDD4-2 or indirect regulation of NCC *via* the ubiquitination and suppression of WNK.

### 3.4. Parvalbumin (PV): an unexpected regulator of NCC and diuretic response

PV is a calcium ( $\text{Ca}^{2+}$ ) binding protein. In neurons and skeletal cell muscles, PV is a calcium buffer capable of modulating calcium currents induced by purinergic agonists such as adenosine triphosphate (ATP, Fig. 2). These calcium currents can cause a decrease in transport systems including those that are involved in  $\text{Na}^+$  reabsorption. PV is selectively expressed in the early part of the mammalian DCT (mDCT) where it co-localizes with the NCC<sup>86,87</sup>. Studies using mDCT cells reveal a decrease in endogenous expression of NCC, WNK1 and WNK4, following PV knockdown<sup>88,89</sup>. The role of PV regulation on the NCC is further emphasized by phenotypic analysis of PV knockout mice that presented mild salt wasting, kaliuresis and enhanced  $\text{Ca}^{2+}$  reabsorption, a phenotype similar to Gitelman syndrome<sup>88</sup>. In addition, the mice exhibited a significant decrease in NCC expression which is reflected by impaired response to diuretics, suggesting a functional link between PV and the NCC. It should be noted that reduced messenger RNA (mRNA) levels of WNK4 and KS-WNK1 were also observed in the PV deficient mice and that the sample size was low<sup>88</sup>.

Further studies demonstrated that PV control of endogenous NCC expression is *via* the ATP-induced  $\text{Ca}^{2+}$  current in mDCT cells. PV was revealed to modulate the shape and the duration of intracellular  $\text{Ca}^{2+}$  signaling by effectively reducing the amplitude of the ATP-induced cytoplasmic  $\text{Ca}^{2+}$  elevation. This finding is consistent with previous work which supported ATP induced inhibition of  $\text{Na}^+$  reabsorption in the DCT *via* purinergic receptors<sup>90</sup>. A study in 2014<sup>91</sup> demonstrated that purinergic receptor activation led to decreased expression of NCC and that the silencing of these receptors reduced ATP-induced downregulation of NCC expression. However, it is important to note that the mice without NCC displayed slightly different pathologies to the mice without PV. The mice without NCC presented with alterations of the DCT, which was not observed in the mice without PV. This suggests that PV is not a significant regulator of NCC and that there may be other variables and pathways that are more influential. This is further supported by transcriptional analysis of Gitelman syndrome patients ( $n = 79$ ;  $P < 0.05$ ) who lack the inactivating mutations in the *SLC12A3* gene that encodes for the NCC but did not reveal mutations in their PV genes<sup>92,93</sup>. As PV

expression has been repeatedly confirmed to be critical for sodium handling and responses to diuretics, the authors of the conflicting study speculate that the negative results could be due to interspecies differences. Although a link between PV expression and a Mendelian disease has not been established, the confirmed phenotype suggests that NCC expression could be indirectly regulated by PV *via* modulations of the ATP-induced  $\text{Ca}^{2+}$  signaling. However, further investigation is needed to evaluate the significance of PV to the regulation of the NCC and tubulopathies in the DCT.

#### 4. Potential therapeutic targets

To date, antihypertensives are insufficient as monotherapy and often provoke multiple off-target side effects<sup>94,95</sup>. The use of thiazides, an antihypertensive that reduces blood pressure by inhibiting the NCC, comes with an increased risk of type II diabetes. Prolonged usage of thiazide diuretics has been shown to increase the membrane density of NCC but not enhanced reabsorption of  $\text{Na}^{+}$ <sup>96,97</sup>. The prevalence of resistant hypertension, defined as uncontrollable blood pressure despite treatment with 3 different antihypertensives, and refractory hypertension, defined as high blood pressure despite maximal therapy, both of which substantially increase the risk of heart attack and stroke, presents a pressing global challenge in treating hypertension<sup>98</sup>. Therefore, new therapeutics targets are urgently needed.

The importance of the NCC in blood pressure regulation is suggested by the monogenic disorders that present with either high or low blood pressure as a result of mutations in the NCC and its regulators. NCC over-activation in particular results in a form of hypertension termed Gordon's syndrome. Gordon's syndrome is caused by mutations in WNKs and in the ubiquitin ligase component that regulates them, CUL3/KLHL3. These genetic defects inappropriately activate the NCC leading to enhanced  $\text{Na}^{+}$  reabsorption, consequently raising blood pressure. As the WNK-SPAK/OSR1 pathway is also the master regulator of NCC, research is focused on identifying novel targets within the pathway for use in Gordon's syndrome and non-Mendelian forms of hypertension.

The WNK-SPAK/OSR1 signaling pathway provides 6 points of intervention. NCC over activation could be attenuated by (1) inhibition of NCC by thiazide diuretics, (2) allosteric or orthosteric inhibition of WNK kinases, (3) direct inhibition of SPAK/OSR1, (4) inhibition of MO25, (5) inhibition of WNK-SPAK/OSR1 interaction, and (6) stabilization of CUL3/KLHL3 interaction. An alternative strategy outside of the WNK-SPAK/OSR1 regulatory pathway is (7) the impairment of glycosylation. A summary of the therapeutic interventions of regulatory mechanisms of NCC is depicted in Fig. 3. As NCC inhibition of thiazide diuretics is a strategy currently used to treat hypertensive patients, this review will focus on the other targets that are not in clinical use.

##### 4.1. Allosteric or orthosteric inhibition of WNK kinases

Despite the overwhelming evidence of WNK-SPAK/OSR1 signaling pathway in blood pressure regulation, there are currently no clinically-approved WNK-SPAK/OSR1 targeting drugs that are used to treat hypertension. Targeting NCC by inhibiting WNK is to date the strategy furthest along the drug discovery pipeline. This is due to the high level of selectivity provided by the irregular placement of the catalytic lysine residue of WNK that creates a

WNK-specific back pocket. ATP-competitive molecules inhibits WNKs orthosterically by exploiting this abnormal structural configuration of WNK<sup>99</sup>. Multiple screenings by various groups identified several inhibitors<sup>100–102</sup>. Notably, a Novartis group screened compounds and identified WNK463, the first orally bioavailable WNK kinase inhibitor. WNK463 prevented WNK-mediated phosphorylation of OSR1 in human embryonic kidney 293 (HEK293) cells expressing OSR1 and produced a dose-dependent decrease in blood pressure in hypertensive rats<sup>103</sup>. However, as the ATP binding site is conserved in all 4 isoforms, WNK463 was found to potently inhibit all isoforms of WNKs (WNK1  $\text{IC}_{50}$  = 5 nmol/L, WNK2  $\text{IC}_{50}$  = 1 nmol/L, WNK3  $\text{IC}_{50}$  = 6 nmol/L, WNK4  $\text{IC}_{50}$  = 9 nmol/L). This posed a challenge as WNKs are ubiquitously expressed and are participants in various physiological processes, thus further development of WNK463 was discontinued due to an unacceptable safety profile. Recent molecular modeling and docking simulations on the binding of WNK463 across all isoforms confirmed the lack of specificity but found that despite the high sequence similarity (>80%) among WNK kinases, the composition of residues in the ATP binding region that produced the marginal differences in selectivity could be exploited<sup>104</sup>. Further screening by the Novartis group found an allosteric binding pocket of WNK1 that co-crystallized with multiple compounds<sup>105</sup>. Inhibitors of allosteric targets provide better selectivity as the region is less conserved in relation to the ATP binding pocket. The list was filtered and compounds were optimized structurally due to selectivity or inadequate pharmacokinetics profile until the discovery of compound **11**. Oral dosing of compound **11** led to reduction in systolic blood pressure, regulated blood fluid, and electrolyte homeostasis in normotensive and hypertensive rodent models in a dose-dependent manner<sup>106</sup>. However, when administered at higher doses, unspecified events beyond those reported in the cardiovascular and renal systems, such as induced ataxia and breathing difficulties, were observed in mice at 1–10 mg/kg doses<sup>107</sup>. These adverse effects may be due to the lack of specificity of WNK463, thus further development of kidney-specific WNK inhibitors are needed in the field for hypertension treatment. Despite the discovery of small molecule inhibitors that are able to inhibit WNKs, a major challenge remains identifying reagents that are able to better differentiate WNK isoforms.

##### 4.2. Inhibition of SPAK/OSR1

Various SPAK mouse models have indicated that inhibition of SPAK and OSR1 may reduce blood pressure. To validate SPAK as a target, researchers have confirmed a reduction in the blood pressure of either SPAK or OSR1 or both in knockout mice<sup>24,108</sup>. The first SPAK and OSR1 kinase inhibitor was reported in 2015 when the Uchida's group<sup>109</sup> developed an enzyme-bound immunosorbent analysis (ELISA) assay that was utilized to screen >20,000 small-molecule compounds in addition to 840 compounds of FDA-approved drugs. This study led to the identification of two structurally related SPAK inhibitors: Stock 1S-14279 ( $\text{IC}_{50}$  = 0.26  $\mu\text{mol/L}$ ) and closantel ( $\text{IC}_{50}$  = 0.7  $\mu\text{mol/L}$ ). Promising *in vitro* studies led to acute administration of both compounds in mice. Despite a rapid drop in blood pressure and heart rate within 30 min and a significant decrease in phosphorylated NCC, the effect of both compounds was transient, lasting only 120 min. Although both compounds have passed critical stages of clinical development and testing, thus are great candidates for hypertensive treatment, repeated injections of Stock 1S-

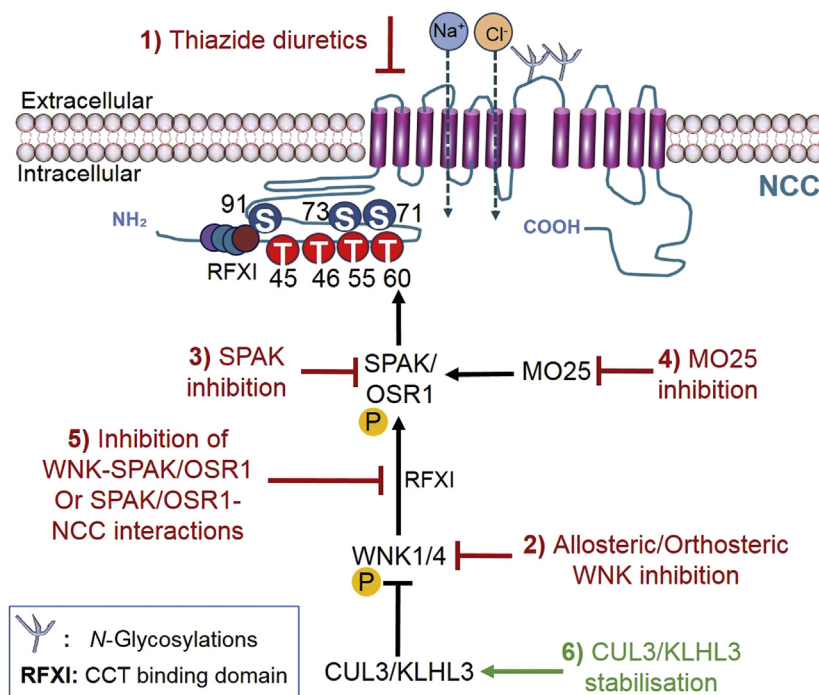

**Figure 3** Summary of therapeutic strategies to target the NCC *via* its regulatory pathway. Over activation of the  $\text{Na}^+\text{--Cl}^-$  co-transporter (NCC) leads to salt retention and hypertension. The CUL3/KLHL3–WNK–SPAK/OSR1 regulatory pathway of NCC (black arrows) presents 6 points of interventions. Red arrows represent the therapeutic inhibition of 1) NCC, 2) WNK, 3) SPAK, 4) MO25, and 5) WNK–SPAK/OSR1 interactions which would all suppress NCC activation. The green arrow represents 6) the stabilisation of CUL3/KLHL3 interactions which would increase degradation of WNK and thus suppress NCC activation by the WNK–SPAK/OSR1 pathway. Glycosylation of the NCC is critical for the function and trafficking of NCC to the plasma membrane and thus (7) impairment of glycosylation could also suppress NCC activity and potentially be therapeutic.

14279 were lethal and prolonged administration of closetel failed to reduce blood pressure by Day 7<sup>109</sup>. Recent molecular studies report that both compounds inhibit SPAK independent of ATP, revealing a highly conserved secondary pocket on the conserved carboxyl-terminal (CCT) domain of SPAK/OSR1<sup>110</sup>. Following the discovery of the secondary pocket, an *in silico* screening was completed by Mehellou and colleagues<sup>111</sup> to identify inhibitory compounds. Rafoxanide, a compound structurally similar to closetel, was identified to inhibit OSR1 in an ATP-dependent manner ( $\text{IC}_{50} = 8.18 \mu\text{mol/L}$ ). However, rafoxanide was only able to inhibit endogenous SPAK and OSR1 in cells at concentrations  $<15 \mu\text{mol/L}$ <sup>110</sup>. Alternatively, recent reports by a group using high-throughput screening of 1200 U.S. Food and Drug Administration (FDA)-approved compounds at  $20 \mu\text{mol/L}$  yielded verteporfin, an inhibitor of SPAK and OSR1 *in vitro* in an ATP-independent manner<sup>111</sup>. Verteporfin binds to an allosteric site adjacent to the kinase domain. Although *in vivo* studies have not been completed, this finding is consistent with the observation of reduced blood pressure in animals treated with verteporfin<sup>112</sup>. However, further screening revealed verteporfin potently inhibits ( $>70\%$ ) 8 other kinases at  $1 \mu\text{mol/L}$ . Therefore, structural optimization of verteporfin will be needed to ensure its selectivity for SPAK/OSR1 to prevent undesirable side effects. Although inhibition of SPAK/OSR1 proves to be a promising strategy, targeting SPAK/OSR1 may disturb the reverse regulation of gamma-aminobutyric acid (GABA) signaling mediated by SPAK in the brain<sup>5</sup>. Additionally, even if the kidney is selectively targeted, adaptive mechanisms to chronic usage of thiazide have been

identified in SPAK knockout mice<sup>97,113–117</sup>. These compensatory changes include DCT remodeling and activation of a paracrine signaling system to induce salt reabsorption pathways in other parts of the nephrons. No data on compensatory action due to OSR1 inhibition could be provided as knockout of OSR1 is embryonic lethal<sup>118</sup>. Nonetheless, inhibitors of SPAK increases therapeutic options, ultimately increasing the number of drugs in trials.

#### 4.3. Inhibition of MO25

As the kinase activity of SPAK and OSR1 is significantly enhanced (80- to 100-fold, respectively) by binding to the scaffolding protein, MO25, a fluorescence polarization assay was used to screen a library of  $\sim 4000$  compounds for inhibitors of SPAK/OSR1–MO25 interaction. The screen uncovered HK01 ( $\text{IC}_{50} = 78 \pm 4 \mu\text{mol/L}$ )<sup>119</sup>. Binding assays confirmed that HK01 binds directly to MO25 and inhibited phosphorylation of NKCC1 in a concentration-dependent manner. Although this approach would only produce limited inhibitory effects on the SPAK/OSR1 kinase activity, this may be desirable as mild reduction could prevent extreme phenotypic effects.

#### 4.4. Inhibition of WNK–SPAK/OSR1 interactions

Alternatively, the observation of reduced phosphorylation of NCC in mice with homozygous mutations in the SPAK CCT domain, a domain which recognizes WNK and NCC, supports for the

inhibition of SPAK CCT domain which interferes with SPAK/OSR1 binding to WNK kinases. Screening of 17,000 compounds identified two compounds, STOCK1S-50699 and STOCK2S-2601 which bind to the SPAK/OSR1 CCT domain<sup>20,120</sup>. Although both compounds exhibited inhibition of SPAK phosphorylation and its downstream targets NCC and NKCC2 in cultured cell lines, STOCK2S-2601 did not suppress SPAK/OSR1 phosphorylation *in vitro* and STOCK1S-50699 displayed undesirable pharmacokinetics *in vivo*. More recently, a potent and selective SPAK inhibitor, ZT-1a, was developed by Zhang et al.<sup>107</sup>. ZT-1a, an amalgamation of pharmacophores, inhibited less than 1% of kinases that were tested and reduced NCC phosphorylation *in vivo*. However, it is not clear whether ZT-1a administration will lead to blood pressure reduction. As research on ZT-1a in the kidney is limited, further studies are needed to investigate its effects in normotensive and hypertensive rodent models.

#### 4.5. Stabilization of CUL3/KLHL3 interaction

The central and multifaceted roles of ubiquitination in modulating NCC activity and expression justify the relevance in identifying modulators of ubiquitination that could be targeted to avoid pathological consequences. Mutations in the E3 ubiquitin ligase complex, KLHL3 and CUL3, prevent the degradation of WNK through disruptions in the binding of the ubiquitin ligase complex<sup>121,122</sup>. Therefore, rather than inhibition, stabilization of CUL3 and KLHL3 interactions may be an approach to lower blood pressure in NCC-dependent hypertension. There are currently no stabilizing molecules that have been reported. As the most severe causative mutations in Gordon's is CUL3>recessive KLHL3>dominant KLHL3>WNK4>WNK1, CUL3/KLHL3 may be mistaken as the most attractive target in the pathway. However, the lack of pharmacological agents or compounds has proven CUL3 to be the most challenging target due to the nature of CUL3 mutations. Mutations in CUL3 produce a modified form of CUL3 that has an enhanced ability to ubiquitinated itself or substrates, one of which is KLHL3<sup>123</sup>. The gain-of-function mutant is also more susceptible to enhanced activation by Nedd8 through a process termed neddylation. Neddylation is the covalent attachment of Nedd8 to CUL3, leading to CUL3 activation and deneddylation is the removal of Nedd8 modifications from CUL3 by the COP9 signalosome. Hence, the inhibition of deneddylation or the promotion of neddylation to increase CUL3 activation and consequently promote WNK degradation could represent viable therapeutic strategies<sup>82</sup>. However, CUL3 over activation may promote off-target self-ubiquitination. Moreover, KLHL3 is highly expressed in the DCT, thus targeting KLHL3 could possibly lead to compensatory adaptations by the kidney as seen in some patients on thiazide diuretics<sup>124</sup>. Accordingly, there is no doubt that significant progress towards understanding the physiological and pathological function of CUL3/KLHL3 is desirable to guide the development of novel antihypertensive drugs. More specifically, the studies discussed suggest that additional chemistry work is needed to identify a specific Nedd8 inhibitor that will allow for the evaluation of Nedd8 as a potential target for the treatment of hypertension.

#### 4.6. Targeting glycosylation

As mentioned previously, NCC functions in a glycosylated state. There are two glycosylation sites in humans (N406 and N426) and rats (N404 and N424). Mutations of both glycosylation sites result

in symptoms resembling Gitelman syndrome. Although impaired glycosylation obstructs folding and processing of the NCC to the plasma membrane, and reduces NCC activity remarkably, elimination of the glycosylation sites in rats increases the affinity to metolazone, a thiazide-like diuretic<sup>125</sup>. There have also been suggestions that the variable glycosylation of NCC accounts for the irregular sensitivity to metolazone among Gitelman disease NCC mutants<sup>126</sup>. Studies using the *X. oocyte* system expressing NCC mutations identified in patients with Gitelman syndrome, exhibited increased metolazone sensitivity<sup>127</sup>. Further studies into novel NCC mutants of Gitelman disease, uncovered a Thr392Ile mutation that displayed severely reduced Na<sup>+</sup> uptake. Due to the close proximity of the Thr392Ile mutation to the glycosylation residues, the mutation may have therefore impaired glycosylation. Studies using Western blot revealed an absence of glycosylated NCC in Thr329Ile mutation<sup>128</sup>. Thus, impaired glycosylation likely obstructs processing of NCC to the plasma membrane, consequently diminishes NCC transport activity and could be a therapeutic strategy in hypertension. Further studies are needed to confirm increased glycosylation in the pathogenesis of hypertension before screening could be done to identify specific compounds targeting glycosylation.

## 5. Conclusions and future directions

The discovery of genetic mutations in monogenic forms of hypertension, coupled with recent molecular and pre-clinical researches, has further elucidated the regulatory mechanisms of NCC activity and expression in blood pressure regulation. NCC is activated by phosphorylation *via* the WNK–SPAK/OSR1 pathway and deactivated by phosphatase-induced dephosphorylation. The expression of NCC is regulated through ubiquitination by ERK1/2, NEDD4-2 and glycosylation. Recent investigations revealed PV as a regulator of NCC through modulation of ATP-induced Ca<sup>2+</sup> signaling. Collectively, these insights illustrate a pharmacological potential to treat hypertension. Indeed, this has already led to the identification and confirmation of molecular targets particularly within the WNK–SPAK/OSR1 pathway. Although there is overwhelming evidence of WNK–SPAK/OSR1 potential as a therapeutic strategy, the drug discovery process is impeded by a lack of selectivity across WNK and SPAK isoforms and the threat of resistance mechanisms by the kidneys. Further studies and screening concerning the inhibition of the ubiquitination and glycosylation of NCC are important and could be beneficial in identifying alternative therapeutic strategies for hypertension.

### Acknowledgment

Maarten P. Koeners is supported by the University of Exeter Medical School (UK). Jinwei Zhang is supported by the University of Exeter Medical School (UK) and NIH Grants R01 NS109358 (USA).

### Author contributions

Nur Farah Meor Azlan, and Jinwei Zhang were responsible for writing the whole passage. Nur Farah Meor Azlan, Maarten P. Koeners, and Jinwei Zhang were in charge of checking and revision. All the figures in the article were made by Nur Farah Meor Azlan and Jinwei Zhang.



## Conflicts of interest

The authors have no conflicts of interest to declare.

## References

- Strazzullo P, Galletti F, Barba G. Altered renal handling of sodium in human hypertension: Short review of the evidence. *Hypertension* 2003;**41**:1000–5.
- He J, Whelton PK. Elevated systolic blood pressure and risk of cardiovascular and renal disease: Overview of evidence from observational epidemiologic studies and randomized controlled trials. *Am Heart J* 1999;**138**:211–9.
- Matsubara M. Renal sodium handling for body fluid maintenance and blood pressure regulation. *Yakugaku Zasshi* 2004;**124**:301–9.
- Subramanya AR, Ellison DH. Distal convoluted tubule. *Clin J Am Soc Nephrol* 2014;**9**:2147–63.
- de Los Heros P, Alessi DR, Gourlay R, Campbell DG, Deak M, Macartney TJ, et al. The WNK-regulated SPAK/OSR1 kinases directly phosphorylate and inhibit the  $K^+$ – $Cl^-$  co-transporters. *Biochem J* 2014;**458**:559–73.
- Castrop H, Schiessl IM. Physiology and pathophysiology of the renal Na–K–2Cl cotransporter (NKCC2). *Am J Physiol Ren Physiol* 2014;**307**:F991–1002.
- Sun M, Ning J, Xu W, Zhang H, Zhao K, Li W, et al. Genetic heterogeneity in patients with Bartter syndrome type 1. *Mol Med Rep* 2017;**15**:581–90.
- Palmer LG, Schnermann J. Integrated control of Na transport along the nephron. *Clin J Am Soc Nephrol* 2015;**10**:676–87.
- Wright JM, Musini VM, Gill R. First-line drugs for hypertension. *Cochrane Database Syst Rev* 2018;**4**:CD001841.
- Wilson FH, Disse-Nicodeme S, Choate KA, Ishikawa K, Nelson-Williams C, Desitter I, et al. Human hypertension caused by mutations in WNK kinases. *Science* 2001;**293**:1107–12.
- de Jong JC, Willems PH, Mooren FJ, van den Heuvel LP, Knoers NV, Bindels RJ. The structural unit of the thiazide-sensitive NaCl cotransporter is a homodimer. *J Biol Chem* 2003;**278**:24302–7.
- Wu A, Wolley M, Stowasser M. The interplay of renal potassium and sodium handling in blood pressure regulation: Critical role of the WNK–SPAK–NCC pathway. *J Hum Hypertens* 2019;**33**:508–23.
- Xu B, English JM, Wilsbacher JL, Stippec S, Goldsmith EJ, Cobb MH. WNK1, a novel mammalian serine/threonine protein kinase lacking the catalytic lysine in subdomain II. *J Biol Chem* 2000;**275**:16795–801.
- Argaiz ER, Chavez-Canales M, Ostrosky-Frid M, Rodriguez-Gama A, Vazquez N, Gonzalez-Rodriguez X, et al. Kidney-specific WNK1 isoform (KS-WNK1) is a potent activator of WNK4 and NCC. *Am J Physiol Ren Physiol* 2018;**315**:F734–45.
- Gong H, Tang Z, Yang Y, Sun L, Zhang W, Wang W, et al. A patient with pseudohypoaldosteronism type II caused by a novel mutation in WNK4 gene. *Endocrine* 2008;**33**:230–4.
- Golbang AP, Murthy M, Hamad A, Liu CH, Cope G, Van't Hoff W, et al. A new kindred with pseudohypoaldosteronism type II and a novel mutation (564D>H) in the acidic motif of the WNK4 gene. *Hypertension* 2005;**46**:295–300.
- Vidal-Petiot E, Elvira-Matlot E, Mutig K, Soukaseum C, Baudrie V, Wu S, et al. WNK1-related familial hyperkalemic hypertension results from an increased expression of L-WNK1 specifically in the distal nephron. *Proc Natl Acad Sci U S A* 2013;**110**:14366–71.
- Takahashi D, Mori T, Nomura N, Khan MZ, Araki Y, Zeniya M, et al. WNK4 is the major WNK positively regulating NCC in the mouse kidney. *Biosci Rep* 2014;**34**:e00107.
- Castaneda-Bueno M, Cervantes-Perez LG, Vazquez N, Uribe N, Kantesaria S, Morla L, et al. Activation of the renal  $Na^+$ – $Cl^-$  cotransporter by angiotensin II is a WNK4-dependent process. *Proc Natl Acad Sci U S A* 2012;**109**:7929–34.
- Vitari AC, Thastrup J, Rafiqi FH, Deak M, Morrice NA, Karlsson HK, et al. Functional interactions of the SPAK/OSR1 kinases with their upstream activator WNK1 and downstream substrate NKCC1. *Biochem J* 2006;**397**:223–31.
- Vitari AC, Deak M, Morrice NA, Alessi DR. The WNK1 and WNK4 protein kinases that are mutated in Gordon's hypertension syndrome phosphorylate and activate SPAK and OSR1 protein kinases. *Biochem J* 2005;**391**:17–24.
- Piechotta K, Lu J, Delpire E. Cation chloride cotransporters interact with the stress-related kinases Ste20-related proline–alanine-rich kinase (SPAK) and oxidative stress response 1 (OSR1). *J Biol Chem* 2002;**277**:50812–9.
- Moriguchi T, Urushiyama S, Hisamoto N, Iemura S, Uchida S, Natsume T, et al. WNK1 regulates phosphorylation of cation-chloride-coupled cotransporters via the STE20-related kinases, SPAK and OSR1. *J Biol Chem* 2005;**280**:42685–93.
- Yang SS, Lo YF, Wu CC, Lin SW, Yeh CJ, Chu P, et al. SPAK-knockout mice manifest Gitelman syndrome and impaired vasoconstriction. *J Am Soc Nephrol* 2010;**21**:1868–77.
- McCormick JA, Mutig K, Nelson JH, Saritas T, Hoorn EJ, Yang CL, et al. A SPAK isoform switch modulates renal salt transport and blood pressure. *Cell Metabol* 2011;**14**:352–64.
- Grimm PR, Taneja TK, Liu J, Coleman R, Chen YY, Delpire E, et al. SPAK isoforms and OSR1 regulate sodium–chloride cotransporters in a nephron-specific manner. *J Biol Chem* 2012;**287**:37673–90.
- Zhang J, Siew K, Macartney T, O'Shaughnessy KM, Alessi DR. Critical role of the SPAK protein kinase CCT domain in controlling blood pressure. *Hum Mol Genet* 2015;**24**:4545–58.
- Burgess K, Jovanovic S, Sudhir R, Jovanovic A. Area under the curve analysis of blood pressure reveals increased spontaneous locomotor activity in SPAK knock-in mice: Relevance for hypotension induced by SPAK inhibition?. *Phys Rep* 2019;**7**:e13997.
- Mandai S, Mori T, Sohara E, Rai T, Uchida S. Generation of hypertension-associated STK39 polymorphism knockin cell lines with the clustered regularly interspaced short palindromic repeats/Cas9 system. *Hypertension* 2015;**66**:1199–206.
- Filippi BM, de los Heros P, Mehellou Y, Navratilova I, Gourlay R, Deak M, et al. MO25 is a master regulator of SPAK/OSR1 and MST3/MST4/YSK1 protein kinases. *EMBO J* 2011;**30**:1730–41.
- Rosenbaek LL, Kortenoeven ML, Aroankins TS, Fenton RA. Phosphorylation decreases ubiquitylation of the thiazide-sensitive cotransporter NCC and subsequent clathrin-mediated endocytosis. *J Biol Chem* 2014;**289**:13347–61.
- Pacheco-Alvarez D, Cristobal PS, Meade P, Moreno E, Vazquez N, Munoz E, et al. The  $Na^+$ – $Cl^-$  cotransporter is activated and phosphorylated at the amino-terminal domain upon intracellular chloride depletion. *J Biol Chem* 2006;**281**:28755–63.
- Wang Y, O'Connell JR, McArdle PF, Wade JB, Dorff SE, Shah SJ, et al. From the cover: Whole-genome association study identifies STK39 as a hypertension susceptibility gene. *Proc Natl Acad Sci U S A* 2009;**106**:226–31.
- Fava C, Danese E, Montagnana M, Sjogren M, Almgren P, Engstrom G, et al. Serine/threonine kinase 39 is a candidate gene for primary hypertension especially in women: Results from two cohort studies in Swedes. *J Hypertens* 2011;**29**:484–91.
- Tobin MD, Raleigh SM, Newhouse S, Braund P, Bodycote C, Ogleby J, et al. Association of WNK1 gene polymorphisms and haplotypes with ambulatory blood pressure in the general population. *Circulation* 2005;**112**:3423–9.
- Putku M, Kepp K, Org E, Sober S, Comas D, Viigimaa M, et al. Novel polymorphic AluYb8 insertion in the WNK1 gene is associated with blood pressure variation in Europeans. *Hum Mutat* 2011;**32**:806–14.
- Newhouse SJ, Wallace C, Dobson R, Mein C, Pembroke J, Farrall M, et al. Haplotypes of the WNK1 gene associate with blood pressure

- variation in a severely hypertensive population from the British genetics of hypertension study. *Hum Mol Genet* 2005;**14**:1805–14.
38. Newhouse S, Farrall M, Wallace C, Hoti M, Burke B, Howard P, et al. Polymorphisms in the *WNK1* gene are associated with blood pressure variation and urinary potassium excretion. *PLoS One* 2009;**4**:e5003.
  39. Guo XG, Ding J, Xu H, Xuan TM, Jin WQ, Yin X, et al. Comprehensive assessment of the association of *WNK4* polymorphisms with hypertension: Evidence from a meta-analysis. *Sci Rep* 2014;**4**:6507.
  40. Rojas-Vega L, Gamba G. Mini-review: Regulation of the renal NaCl cotransporter by hormones. *Am J Physiol Ren Physiol* 2016;**310**:F10–4.
  41. Vitzthum H, Seniuk A, Schulte LH, Muller ML, Hetz H, Ehmke H. Functional coupling of renal  $K^+$  and  $Na^+$  handling causes high blood pressure in  $Na^+$  replete mice. *J Physiol* 2014;**592**:1139–57.
  42. Terker AS, Zhang C, McCormick JA, Lazelle RA, Zhang C, Meermeier NP, et al. Potassium modulates electrolyte balance and blood pressure through effects on distal cell voltage and chloride. *Cell Metabol* 2015;**21**:39–50.
  43. Kotchen TA, Cowley Jr AW, Frohlich ED. Salt in health and disease—a delicate balance. *N Engl J Med* 2013;**368**:2531–2.
  44. Chiga M, Rai T, Yang SS, Ohta A, Takizawa T, Sasaki S, et al. Dietary salt regulates the phosphorylation of OSR1/SPAK kinases and the sodium chloride cotransporter through aldosterone. *Kidney Int* 2008;**74**:1403–9.
  45. Terker AS, Zhang C, Erspamer KJ, Gamba G, Yang CL, Ellison DH. Unique chloride-sensing properties of WNK4 permit the distal nephron to modulate potassium homeostasis. *Kidney Int* 2016;**89**:127–34.
  46. Terker AS, Yarbrough B, Ferdaus MZ, Lazelle RA, Erspamer KJ, Meermeier NP, et al. Direct and indirect mineralocorticoid effects determine distal salt transport. *J Am Soc Nephrol* 2016;**27**:2436–45.
  47. Nishida H, Sohara E, Nomura N, Chiga M, Alessi DR, Rai T, et al. Phosphatidylinositol 3-kinase/Akt signaling pathway activates the WNK–OSR1/SPAK–NCC phosphorylation cascade in hyperinsulinemic *db/db* mice. *Hypertension* 2012;**60**:981–90.
  48. Furusho T, Uchida S, Sohara E. The WNK signaling pathway and salt-sensitive hypertension. *Hypertens Res* 2020;**43**:733–43.
  49. Glover M, Mercier Zuber A, Figg N, O'Shaughnessy KM. The activity of the thiazide-sensitive  $Na^+–Cl^-$  cotransporter is regulated by protein phosphatase PP4. *Can J Physiol Pharmacol* 2010;**88**:986–95.
  50. Gamba G. Regulation of the renal  $Na^+–Cl^-$  cotransporter by phosphorylation and ubiquitylation. *Am J Physiol Ren Physiol* 2012;**303**:F1573–83.
  51. Zununi Vahed S, Ardalan M, Samadi N, Omidi Y. Pharmacogenetics and drug-induced nephrotoxicity in renal transplant recipients. *Bioimpacts* 2015;**5**:45–54.
  52. Shoda W, Nomura N, Ando F, Mori Y, Mori T, Sohara E, et al. Calcineurin inhibitors block sodium–chloride cotransporter dephosphorylation in response to high potassium intake. *Kidney Int* 2017;**91**:402–11.
  53. Melnikov S, Mayan H, Uchida S, Holtzman EJ, Farfel Z. Cyclosporine metabolic side effects: Association with the WNK4 system. *Eur J Clin Invest* 2011;**41**:1113–20.
  54. Hoorn EJ, Walsh SB, McCormick JA, Furstenberg A, Yang CL, Roeschel T, et al. The calcineurin inhibitor tacrolimus activates the renal sodium chloride cotransporter to cause hypertension. *Nat Med* 2011;**17**:1304–9.
  55. Penton D, Moser S, Wengi A, Czogalla J, Rosenbaek LL, Rigendinger F, et al. Protein phosphatase 1 inhibitor-1 mediates the cAMP-dependent stimulation of the renal NaCl cotransporter. *J Am Soc Nephrol* 2019;**30**:737–50.
  56. Picard N, Trompf K, Yang CL, Miller RL, Carrel M, Loffing-Cueni D, et al. Protein phosphatase 1 inhibitor-1 deficiency reduces phosphorylation of renal NaCl cotransporter and causes arterial hypotension. *J Am Soc Nephrol* 2014;**25**:511–22.
  57. Gagnon KB, Delpire E. Multiple pathways for protein phosphatase 1 (PP1) regulation of  $Na–K–2Cl$  cotransporter (NKCC1) function: The N-terminal tail of the  $Na–K–2Cl$  cotransporter serves as a regulatory scaffold for Ste20-related proline/alanine-rich kinase (SPAK) AND PP1. *J Biol Chem* 2010;**285**:14115–21.
  58. Murillo-de-Ozores AR, Rodriguez-Gama A, Bazua-Valenti S, Leyva-Rios K, Vazquez N, Pacheco-Alvarez D, et al. C-terminally truncated, kidney-specific variants of the WNK4 kinase lack several sites that regulate its activity. *J Biol Chem* 2018;**293**:12209–21.
  59. Plotkin MD, Kaplan MR, Verlander JW, Lee WS, Brown D, Poch E, et al. Localization of the thiazide sensitive  $Na–Cl$  cotransporter, rTSC1 in the rat kidney. *Kidney Int* 1996;**50**:174–83.
  60. Gamba G, Miyanoshita A, Lombardi M, Lytton J, Lee WS, Hediger MA, et al. Molecular cloning, primary structure, and characterization of two members of the mammalian electroneutral sodium–(potassium)–chloride cotransporter family expressed in kidney. *J Biol Chem* 1994;**269**:17713–22.
  61. Mount DB. Regulated endocytosis of NCC. *Am J Physiol Ren Physiol* 2010;**299**:F297–9.
  62. Soundararajan R, Zhang TT, Wang J, Vandewalle A, Pearce D. A novel role for glucocorticoid-induced leucine zipper protein in epithelial sodium channel-mediated sodium transport. *J Biol Chem* 2005;**280**:39970–81.
  63. Babilonia E, Li D, Wang Z, Sun P, Lin DH, Jin Y, et al. Mitogen-activated protein kinases inhibit the ROMK (Kir 1.1)-like small conductance K channels in the cortical collecting duct. *J Am Soc Nephrol* 2006;**17**:2687–96.
  64. Ko B, Kamsteeg EJ, Cooke LL, Moddes LN, Deen PM, Hoover RS. RasGRP1 stimulation enhances ubiquitination and endocytosis of the sodium–chloride cotransporter. *Am J Physiol Ren Physiol* 2010;**299**:F300–9.
  65. Ko B, Joshi LM, Cooke LL, Vazquez N, Musch MW, Hebert SC, et al. Phorbol ester stimulation of RasGRP1 regulates the sodium–chloride cotransporter by a PKC-independent pathway. *Proc Natl Acad Sci U S A* 2007;**104**:20120–5.
  66. Yang CL, Angell J, Mitchell R, Ellison DH. WNK kinases regulate thiazide-sensitive  $Na–Cl$  cotransport. *J Clin Invest* 2003;**111**:1039–45.
  67. Zhou B, Zhuang J, Gu D, Wang H, Cebotaru L, Guggino WB, et al. WNK4 enhances the degradation of NCC through a sortilin-mediated lysosomal pathway. *J Am Soc Nephrol* 2010;**21**:82–92.
  68. Subramanya AR, Liu J, Ellison DH, Wade JB, Welling PA. WNK4 diverts the thiazide-sensitive NaCl cotransporter to the lysosome and stimulates AP-3 interaction. *J Biol Chem* 2009;**284**:18471–80.
  69. Cai H, Cebotaru V, Wang YH, Zhang XM, Cebotaru L, Guggino SE, et al. WNK4 kinase regulates surface expression of the human sodium chloride cotransporter in mammalian cells. *Kidney Int* 2006;**69**:2162–70.
  70. Zhou B, Wang D, Feng X, Zhang Y, Wang Y, Zhuang J, et al. WNK4 inhibits NCC protein expression through MAPK ERK1/2 signaling pathway. *Am J Physiol Ren Physiol* 2012;**302**:F533–9.
  71. Lupp A, Klenk C, Rocken C, Evert M, Mawrin C, Schulz S. Immunohistochemical identification of the PTHR1 parathyroid hormone receptor in normal and neoplastic human tissues. *Eur J Endocrinol* 2010;**162**:979–86.
  72. Ko B, Cooke LL, Hoover RS. Parathyroid hormone (PTH) regulates the sodium chloride cotransporter via Ras guanyl releasing protein 1 (Ras-GRP1) and extracellular signal-regulated kinase (ERK)1/2 mitogen-activated protein kinase (MAPK) pathway. *Transl Res* 2011;**158**:282–9.
  73. Feng X, Zhang Y, Shao N, Wang Y, Zhuang Z, Wu P, et al. Aldosterone modulates thiazide-sensitive sodium chloride cotransporter abundance via DUSP6-mediated ERK1/2 signaling pathway. *Am J Physiol Ren Physiol* 2015;**308**:F1119–27.
  74. Rosenbaek LL, Rizzo F, Wu Q, Rojas-Vega L, Gamba G, MacAulay N, et al. The thiazide sensitive sodium chloride co-

- transporter NCC is modulated by site-specific ubiquitylation. *Sci Rep* 2017;**7**:12981.
75. Hossain Khan MZ, Sohara E, Ohta A, Chiga M, Inoue Y, Isobe K, et al. Phosphorylation of Na-Cl cotransporter by OSR1 and SPAK kinases regulates its ubiquitination. *Biochem Biophys Res Commun* 2012;**425**:456–61.
  76. Rotin D, Staub O. Nedd4-2 and the regulation of epithelial sodium transport. *Front Physiol* 2012;**3**:212.
  77. Ronzaud C, Loffing-Cueni D, Hausel P, Debonneville A, Malsure SR, Fowler-Jaeger N, et al. Renal tubular NEDD4-2 deficiency causes NCC-mediated salt-dependent hypertension. *J Clin Invest* 2013;**123**:657–65.
  78. Arroyo JP, Lagnaz D, Ronzaud C, Vazquez N, Ko BS, Moddes L, et al. Nedd4-2 modulates renal Na<sup>+</sup>-Cl<sup>-</sup> cotransporter via the aldosterone-SGK1-Nedd4-2 pathway. *J Am Soc Nephrol* 2011;**22**:1707–19.
  79. Lagnaz D, Arroyo JP, Chavez-Canales M, Vazquez N, Rizzo F, Spirli A, et al. WNK3 abrogates the NEDD4-2-mediated inhibition of the renal Na<sup>+</sup>-Cl<sup>-</sup> cotransporter. *Am J Physiol Ren Physiol* 2014;**307**:F275–86.
  80. Lai F, Orelli BJ, Till BG, Godley LA, Fernald AA, Pamintuan L, et al. Molecular characterization of KLHL3, a human homologue of the *Drosophila kelch* gene. *Genomics* 2000;**66**:65–75.
  81. Wu G, Peng JB. Disease-causing mutations in KLHL3 impair its effect on WNK4 degradation. *FEBS Lett* 2013;**587**:1717–22.
  82. Shibata S, Zhang J, Puthumana J, Stone KL, Lifton RP. Kelch-like 3 and cullin 3 regulate electrolyte homeostasis via ubiquitination and degradation of WNK4. *Proc Natl Acad Sci U S A* 2013;**110**:7838–43.
  83. Ohta A, Schumacher FR, Mehellou Y, Johnson C, Knebel A, Macartney TJ, et al. The CUL3-KLHL3 E3 ligase complex mutated in Gordon's hypertension syndrome interacts with and ubiquitylates WNK isoforms: Disease-causing mutations in KLHL3 and WNK4 disrupt interaction. *Biochem J* 2013;**451**:111–22.
  84. Susa K, Sohara E, Rai T, Zeniya M, Mori Y, Mori T, et al. Impaired degradation of WNK1 and WNK4 kinases causes PHAI1 in mutant KLHL3 knock-in mice. *Hum Mol Genet* 2014;**23**:5052–60.
  85. Mori Y, Wakabayashi M, Mori T, Araki Y, Sohara E, Rai T, et al. Decrease of WNK4 ubiquitination by disease-causing mutations of KLHL3 through different molecular mechanisms. *Biochem Biophys Res Commun* 2013;**439**:30–4.
  86. Loffing J, Loffing-Cueni D, Valderrabano V, Klausli L, Hebert SC, Rossier BC, et al. Distribution of transcellular calcium and sodium transport pathways along mouse distal nephron. *Am J Physiol Ren Physiol* 2001;**281**:F1021–7.
  87. Bindels RJ, Timmermans JA, Hartog A, Coers W, van Os CH. Calbindin-D9k and parvalbumin are exclusively located along basolateral membranes in rat distal nephron. *J Am Soc Nephrol* 1991;**2**:1122–9.
  88. Belge H, Gailly P, Schwaller B, Loffing J, Debaix H, Riveira-Munoz E, et al. Renal expression of parvalbumin is critical for NaCl handling and response to diuretics. *Proc Natl Acad Sci U S A* 2007;**104**:14849–54.
  89. Zacchia M, Capasso G. Parvalbumin: A key protein in early distal tubule NaCl reabsorption. *Nephrol Dial Transplant* 2008;**23**:1109–11.
  90. Leipziger J. Control of epithelial transport via luminal P2 receptors. *Am J Physiol Ren Physiol* 2003;**284**:F419–32.
  91. Gailly P, Szutkowska M, Olinger E, Debaix H, Seghers F, Janas S, et al. P2Y2 receptor activation inhibits the expression of the sodium-chloride cotransporter NCC in distal convoluted tubule cells. *Pflügers Archiv* 2014;**466**:2035–47.
  92. Riveira-Munoz E, Devuyt O, Belge H, Jeck N, Strompf L, Vargas-Poussou R, et al. Evaluating PVALB as a candidate gene for SLC12A3-negative cases of Gitelman's syndrome. *Nephrol Dial Transplant* 2008;**23**:3120–5.
  93. Riveira-Munoz E, Chang Q, Godefroid N, Hoenderop JG, Bindels RJ, Dahan K, et al. Transcriptional and functional analyses of SLC12A3 mutations: New clues for the pathogenesis of Gitelman syndrome. *J Am Soc Nephrol* 2007;**18**:1271–83.
  94. Sica DA. Diuretic-related side effects: Development and treatment. *J Clin Hypertens (Greenwich)* 2004;**6**:532–40.
  95. Maitland-van der Zee AH, Turner ST, Schwartz GL, Chapman AB, Klungel OH, Boerwinkle E. Demographic, environmental, and genetic predictors of metabolic side effects of hydrochlorothiazide treatment in hypertensive subjects. *Am J Hypertens* 2005;**18**:1077–83.
  96. Morsing P, Velazquez H, Wright FS, Ellison DH. Adaptation of distal convoluted tubule of rats. II. Effects of chronic thiazide infusion. *Am J Physiol* 1991;**261**:F137–43.
  97. Kim GH. Long-term adaptation of renal ion transporters to chronic diuretic treatment. *Am J Nephrol* 2004;**24**:595–605.
  98. Kamel KS, Ethier JH, Quaggin S, Levin A, Albert S, Carlisle EJ, et al. Studies to determine the basis for hyperkalemia in recipients of a renal transplant who are treated with cyclosporine. *J Am Soc Nephrol* 1992;**2**:1279–84.
  99. Knighton DR, Zheng JH, Ten Eyck LF, Ashford VA, Xuong NH, Taylor SS, et al. Crystal structure of the catalytic subunit of cyclic adenosine monophosphate-dependent protein kinase. *Science* 1991;**253**:407–14.
  100. Yagi YI, Abe K, Ikebukuro K, Sode K. Kinetic mechanism and inhibitor characterization of WNK1 kinase. *Biochemistry* 2009;**48**:10255–66.
  101. Elkins JM, Fedele V, Szklarz M, Abdul Azeez KR, Salah E, Mikolajczyk J, et al. Comprehensive characterization of the published kinase inhibitor set. *Nat Biotechnol* 2016;**34**:95–103.
  102. Apsel B, Blair JA, Gonzalez B, Nazif TM, Feldman ME, Aizenstein B, et al. Targeted polypharmacology: Discovery of dual inhibitors of tyrosine and phosphoinositide kinases. *Nat Chem Biol* 2008;**4**:691–9.
  103. Yamada K, Park HM, Rigel DF, DiPetrillo K, Whalen EJ, Anisowicz A, et al. Small-molecule WNK inhibition regulates cardiovascular and renal function. *Nat Chem Biol* 2016;**12**:896–8.
  104. Jonniya NA, Kar P. Investigating specificity of the anti-hypertensive inhibitor WNK463 against with-no-lysine kinase family isoforms via multiscale simulations. *J Biomol Struct Dyn* 2020;**38**:1306–21.
  105. Yamada K, Zhang JH, Xie X, Reinhardt J, Xie AQ, LaSala D, et al. Discovery and characterization of allosteric WNK kinase inhibitors. *ACS Chem Biol* 2016;**11**:3338–46.
  106. Yamada K, Levell J, Yoon T, Kohls D, Yowe D, Rigel DF, et al. Optimization of allosteric with-no-lysine (WNK) kinase inhibitors and efficacy in rodent hypertension models. *J Med Chem* 2017;**60**:7099–107.
  107. Zhang J, Bhuiyan MIH, Zhang T, Karimy JK, Wu Z, Fiesler VM, et al. Modulation of brain cation-Cl<sup>-</sup> cotransport via the SPAK kinase inhibitor ZT-1a. *Nat Commun* 2020;**11**:78.
  108. Lin SH, Yu IS, Jiang ST, Lin SW, Chu P, Chen A, et al. Impaired phosphorylation of Na<sup>+</sup>-K<sup>+</sup>-2Cl<sup>-</sup> cotransporter by oxidative stress-responsive kinase-1 deficiency manifests hypotension and Bartter-like syndrome. *Proc Natl Acad Sci U S A* 2011;**108**:17538–43.
  109. Kikuchi E, Mori T, Zeniya M, Isobe K, Ishigami-Yuasa M, Fujii S, et al. Discovery of novel SPAK inhibitors that block WNK kinase signaling to cation chloride transporters. *J Am Soc Nephrol* 2015;**26**:1525–36.
  110. AlAmri MA, Kadri H, Alderwick LJ, Simpkins NS, Mehellou Y. Rafoxanide and closantel inhibit SPAK and OSR1 kinases by binding to a highly conserved allosteric site on their C-terminal domains. *ChemMedChem* 2017;**12**:639–45.
  111. AlAmri MA, Kadri H, Alderwick LJ, Jeeves M, Mehellou Y. The photosensitising clinical agent verteporfin is an inhibitor of SPAK and OSR1 kinases. *Chembiochem* 2018;**19**:2072–80.
  112. Charisis SK, Naoumidi II, Ginis HS, Detorakis ET, Tsilimbaris MK. Contact transcleral ciliary body photodynamic therapy with

- verteporfin in pigmented rabbits: Effect of repeated treatments. *Photochem Photobiol* 2010;**86**:194–9.
113. Yang SS, Huang CL, Chen HE, Tung CS, Shih HP, Liu YP. Effects of SPAK knockout on sensorimotor gating, novelty exploration, and brain area-dependent expressions of NKCC1 and KCC2 in a mouse model of schizophrenia. *Prog Neuro-Psychopharmacol Biol Psychiatry* 2015;**61**:30–6.
114. Loffing J, Vallon V, Loffing-Cueni D, Aregger F, Richter K, Pietri L, et al. Altered renal distal tubule structure and renal Na<sup>+</sup> and Ca<sup>2+</sup> handling in a mouse model for Gitelman's syndrome. *J Am Soc Nephrol* 2004;**15**:2276–88.
115. Grimm PR, Lazo-Fernandez Y, Delpire E, Wall SM, Dorsey SG, Weinman EJ, et al. Integrated compensatory network is activated in the absence of NCC phosphorylation. *J Clin Invest* 2015;**125**:2136–50.
116. Geng Y, Byun N, Delpire E. Behavioral analysis of Ste20 kinase SPAK knockout mice. *Behav Brain Res* 2010;**208**:377–82.
117. Brooks HL, Sorensen AM, Terris J, Schultheis PJ, Lorenz JN, Shull GE, et al. Profiling of renal tubule Na<sup>+</sup> transporter abundances in NHE3 and NCC null mice using targeted proteomics. *J Physiol* 2001;**530**:359–66.
118. Delpire E, Gagnon KB. SPAK and OSR1: STE20 kinases involved in the regulation of ion homeostasis and volume control in mammalian cells. *Biochem J* 2008;**409**:321–31.
119. Kadri H, Alamri MA, Navratilova IH, Alderwick LJ, Simpkins NS, Mehellou Y. Towards the development of small-molecule MO25 binders as potential indirect SPAK/OSR1 kinase inhibitors. *Chem-biochem* 2017;**18**:460–5.
120. Mori T, Kikuchi E, Watanabe Y, Fujii S, Ishigami-Yuasa M, Kagechika H, et al. Chemical library screening for WNK signalling inhibitors using fluorescence correlation spectroscopy. *Biochem J* 2013;**455**:339–45.
121. Louis-Dit-Picard H, Barc J, Trujillano D, Miserey-Lenkei S, Bouatia-Naji N, Pylypenko O, et al. KLHL3 mutations cause familial hyperkalemic hypertension by impairing ion transport in the distal nephron. *Nat Genet* 2012;**44**:456–60. S1-3.
122. Boyden LM, Choi M, Choate KA, Nelson-Williams CJ, Farhi A, Toka HR, et al. Mutations in kelch-like 3 and cullin 3 cause hypertension and electrolyte abnormalities. *Nature* 2012;**482**:98–102.
123. McCormick JA, Yang CL, Zhang C, Davidge B, Blankenstein KI, Terker AS, et al. Hyperkalemic hypertension-associated cullin 3 promotes WNK signaling by degrading KLHL3. *J Clin Invest* 2014;**124**:4723–36.
124. Sasaki E, Susa K, Mori T, Isobe K, Araki Y, Inoue Y, et al. KLHL3 knockout mice reveal the physiological role of KLHL3 and the pathophysiology of pseudohypoaldosteronism type II caused by mutant KLHL3. *Mol Cell Biol* 2017;**37**:e00508–16.
125. Hoover RS, Poch E, Monroy A, Vazquez N, Nishio T, Gamba G, et al. N-Glycosylation at two sites critically alters thiazide binding and activity of the rat thiazide-sensitive Na<sup>+</sup>:Cl<sup>-</sup> cotransporter. *J Am Soc Nephrol* 2003;**14**:271–82.
126. Sabath E, Meade P, Berkman J, de los Heros P, Moreno E, Bobadilla NA, et al. Pathophysiology of functional mutations of the thiazide-sensitive Na–Cl cotransporter in Gitelman disease. *Am J Physiol Ren Physiol* 2004;**287**:F195–203.
127. De Jong JC, Van Der Vliet WA, Van Den Heuvel LP, Willems PH, Knoers NV, Bindels RJ. Functional expression of mutations in the human NaCl cotransporter: Evidence for impaired routing mechanisms in Gitelman's syndrome. *J Am Soc Nephrol* 2002;**13**:1442–8.
128. Glaudemans B, Yntema HG, San-Cristobal P, Schoots J, Pfundt R, Kamsteeg EJ, et al. Novel NCC mutants and functional analysis in a new cohort of patients with Gitelman syndrome. *Eur J Hum Genet* 2012;**20**:263–70.