

ORIGINAL ARTICLE

Effect of chemotherapy and longitudinal analysis of circulating extracellular vesicle tissue factor activity in patients with pancreatic and colorectal cancer

Raj S. Kasthuri MBBS, MD^{1,2}  | Yohei Hisada PhD^{1,2}  | Anton Ilich MD^{1,2} | Nigel S. Key MB, ChB, FRCP^{1,2} | Nigel Mackman PhD, FAHA^{1,2}

¹Division of Hematology/Oncology, Department of Medicine, University of North Carolina at Chapel Hill, Chapel Hill, North Carolina

²Blood Research Center, University of North Carolina at Chapel Hill, Chapel Hill, North Carolina

Correspondence

Raj S. Kasthuri, Division of Hematology/Oncology, University of North Carolina at Chapel Hill, 8206B, Mary Ellen Jones Bldg, 116 Manning Drive, CB 7035, Chapel Hill, NC 27599-7035.
Email: raj_kasthuri@med.unc.edu

Funding information

Funding was provided by the National Institutes of Health HL095096 (NSK and NM), T32 HL007149 (YH), the Japanese Society on Thrombosis and Hemostasis (YH), the John C. Parker Professorship (NM).

Handling Editor: Yotis Senis.

Abstract

Introduction: We conducted a longitudinal study in patients with pancreatic and colorectal cancer. We determined the effect of chemotherapy on extracellular vesicle tissue factor (EVTF) activity and the association of plasma EVTF activity with venous thromboembolism (VTE) and survival.

Material and Methods: We enrolled 13 patients with pancreatic and 22 patients with colorectal cancer. Plasma samples were collected during the 85-day study period. Patients were followed for 3 months after the study period. We recorded symptomatic VTE during the study period (3 months) or asymptomatic deep vein thrombosis detected by ultrasound at day 85. We measured EVTF activity before and after chemotherapy.

Results and Conclusions: In the pancreatic cancer group, 2 patients had elevated levels of EVTF activity. One of these patients developed symptomatic VTE and died, and the second patient did not have a VTE but died. Chemotherapy decreased EVTF activity in 2 pancreatic patients with high levels. In the colorectal cancer group, 4 patients developed VTE, but EVTF activity was not elevated in any patient and no patient died. We observed a borderline significant correlation between EVTF activity and D-dimer in the patients with pancreatic but not colorectal cancer. In this small descriptive study, 2 patients with pancreatic cancer had an elevated level of EVTF activity. Both patients died during the study period, and one had a VTE. Chemotherapy decreased EVTF activity in these patients. In contrast, elevated levels of EVTF activity were not observed in patients with colorectal cancer with or without VTE.

KEYWORDS

cancer, chemotherapy, extracellular vesicles, tissue factor, venous thromboembolism

This is an open access article under the terms of the Creative Commons Attribution-NonCommercial-NoDerivs License, which permits use and distribution in any medium, provided the original work is properly cited, the use is non-commercial and no modifications or adaptations are made.

© 2020 The Authors. *Research and Practice in Thrombosis and Haemostasis* published by Wiley Periodicals, Inc on behalf of International Society on Thrombosis and Haemostasis.

Essentials

- Longitudinal prospective study to measure plasma extracellular vesicle tissue factor (EVTF) activity in patients with cancer.
- Plasma samples were collected before and after chemotherapy.
- Only 17% of the target number of patients with pancreatic and colorectal cancer were enrolled.
- Chemotherapy decreased EVTF activity in the 2 patients with pancreatic cancer with high levels.

1 | INTRODUCTION

Patients with cancer have an increased risk for the development of venous thromboembolism (VTE).¹ The use of cytotoxic therapies further increases the thrombotic risk.²⁻⁴ Patients with cancer and VTE also have a worse prognosis and decreased overall survival compared to those without VTE.^{5,6} Several factors determine risk for VTE in cancer. These include site, stage, and grade of cancer.^{7,8} Brain and pancreatic cancers confer the highest risk for VTE.^{1,9-11} Metastatic disease, either regional or distant, is also associated with greater risk for VTE compared to local disease.^{6,12}

Many studies have determined the association between different clinical characteristics and/or biomarkers and VTE in an attempt to predict VTE in patients with cancer.¹³ This has led to the development of several risk assessment scores. The Khorana score is the most commonly used tool in ambulatory patients who are at increased risk for chemotherapy-associated thrombosis.¹⁴ The score includes 5 components (cancer site, leukocytosis, thrombocytosis, body mass index, and low hemoglobin and/or use of erythropoiesis-stimulating agents). Ay and colleagues¹⁵ improved the predictive value of the Khorana score by adding the circulating biomarkers D-dimer and soluble P-selectin. However, cancer site seems to be the dominant factor in the Khorana score, and one study found that only 37.5% of patients with pancreatic cancer with VTE had a high risk score (≥ 3).¹⁶ More recently, a new score was proposed for predicting VTE in ambulatory patients with cancer with solid tumors that includes only cancer site and D-dimer.¹⁷

The mechanisms by which cancer increases VTE risk is likely multifactorial, and there may be different pathways in different cancer types.^{8,18} Tissue factor (TF) is a potent procoagulant protein that is not normally present in blood.¹⁹ Tumors release TF-positive extracellular vesicles (EVs) into the circulation.²⁰ Cytotoxic chemotherapy might be expected to increase circulating levels of EVTF in patients with cancer by killing TF-positive tumor cells. However, an exploratory, prospective study found that chemotherapy did not induce detectable levels of EVTF activity in metastatic testicular cancer.²¹ Further, another study found that chemotherapy paradoxically reduced plasma levels of EVTF activity in multiple myeloma.²²

We measured EVTF activity in a small longitudinal prospective study of 10 patients with pancreatic cancer, 2 of whom developed VTE.²³ Interestingly, EVTF activity increased in a stepwise manner prior to VTE in these 2 patients. In subsequent prospective studies with single samples, we observed an association between EVTF activity and VTE in 117 patients with pancreaticobiliary cancer, and a borderline association of EVTF activity and VTE in 60 patients with

pancreatic cancer.^{24,25} Another study with 79 patients with pancreatic cancer also observed an association between EVTF activity and VTE.²⁶ However, plasma EVTF activity was not associated with VTE in the general cancer population (multiple tumor types included), nor in patients with colorectal, gastric, brain, or ovarian cancer or multiple myeloma.^{22,24,27,28} We and others have also observed an association between EVTF activity and survival in a general cancer population and also specifically in pancreatic cancer.^{24,25,27}

The vast majority of studies evaluating biomarkers of thrombotic risk in cancer have used blood samples obtained at a single time point.¹³ There are very few longitudinal studies evaluating biomarkers in patients with cancer over the course of their treatment.^{29,30} One study collected samples monthly from 112 patients with cancer and found that increased levels of factor VIII, D-dimer, and soluble P-selectin were associated with VTE and decreased survival.³⁰

We conducted a longitudinal, multicenter observational study in patients with pancreatic and colorectal cancer receiving standard-of-care chemotherapy. Plasma samples were collected before and after chemotherapy. The objectives of the study were to (1) determine whether chemotherapy led to an increase in circulating EVTF activity and (2) determine if EVTF activity is associated with VTE and survival in the study population.

2 | METHODS

2.1 | Study design and sample collection

We conducted a prospective, observational study in patients with newly diagnosed, local or metastatic pancreatic ductal adenocarcinoma (PDAC) or colorectal cancer (CRC). Patients were enrolled prior to initiation of chemotherapy. The study was conducted following approval from the University of North Carolina Institutional Review Board at all 4 participating sites within the UNC HealthCare system (UNC, Rex, Nash County and Southeastern Medical Oncology Center), and informed consent was obtained from all participants. Specific demographic and disease-related information was collected from all subjects. Patient enrollment and study-related follow-up occurred between October 2009 and December 2013. Specific demographic and disease-related information was collected from all subjects. Lower extremity venous duplex ultrasound (CUS) was performed on all study subjects at enrollment (prior to initiation of chemotherapy) and at 3 months (day 85 ± 5 days; ie, end of study period). Symptomatic or asymptomatic ultrasound-identified deep vein thrombosis (DVT) was recorded. Pulmonary emboli (PE) that

were clinically apparent or asymptomatic (eg, during staging computed tomography scanning) were also recorded. The study schematic is outlined in Figure 1. The schematic was developed based on the standard first-line therapy for pancreatic cancer (gemcitabine) and colorectal cancer (FOLFOX ± bevacizumab) at the time that the study was initiated. All study subjects were followed for 3 months after completion of study period, and data on clinical outcomes were recorded.

2.1.1 | Inclusion criteria

Inclusion criteria included age > 18 years and pancreatic or colorectal cancer.

2.1.2 | Exclusion criteria

Exclusion criteria included (1) surgery within the past month (excluding diagnostic biopsies); (2) hospitalization for >2 days in the past month; (3) prior chemotherapy; (4) history of VTE; (5) currently on anticoagulation therapy; (6) inferior vena cava filter; (7) patient refuses, or is deemed unsuitable for, chemotherapy; or (8) currently pregnant.

Presence/placement of central venous catheters and use of antiplatelet agents was allowed.

2.1.3 | Outcomes

The primary study outcome was symptomatic VTE during the study period (first 3 months) or asymptomatic, ultrasound-detected proximal or distal DVT at day 85. Secondary outcomes included (1) death; (2) arterial thrombosis (ischemic stroke, myocardial infarction, or peripheral arterial occlusion); and (3) symptomatic VTE occurring beyond day 85 but before the end of the total study period (6 months total).

2.2 | Collection of blood samples

We collected prechemotherapy (days 1 and 43) blood samples and blood samples 1-hour after chemotherapy on day 2 cycle 1, and 1 hour after chemotherapy on day 44 cycle 3 for the patients with PDAC. We also collected prechemotherapy (days 1 and 57) samples and 1-hour samples on day 2, and day 3 postchemotherapy samples at cycle 1, and 1-hour day 58 and day 59 postchemotherapy samples at cycle 5 for the patients with CRC. Blood samples were collected into citrate anticoagulant at baseline and at subsequent prespecified time points. Blood samples were kept at room temperature and processed within 2 hours of collection. Platelet-poor plasma was prepared by centrifugation of blood at 1500 g for 15 minutes, then divided into 0.5-mL aliquots and frozen for batch analysis.

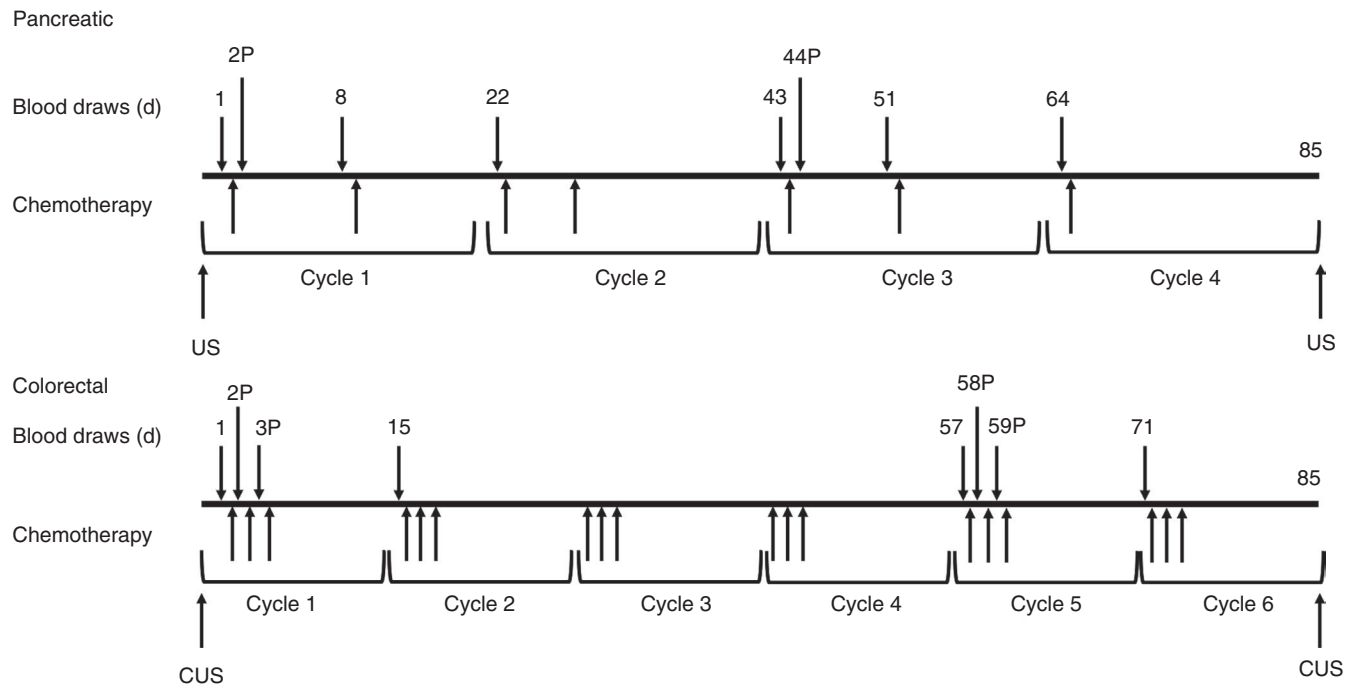

FIGURE 1 Study schema. The chemotherapy cycle for patients with pancreatic cancer is 21 days. We collected samples before cycles 1, 2, 3, and 4 and in the middle of cycles 1 and 3. We also collected samples 1 hour after chemotherapy in cycles 1 and 3 (labeled with P). The chemotherapy cycle for patients with colorectal cancer is 14 days. We collected samples before cycles 1, 2, 5, and 6. We also collected samples 1 hour after chemotherapy in cycles 1 and 5 (labeled with a P). CUS was performed at baseline to exclude any patients with asymptomatic deep vein thrombosis, and also at day 85. CUS, venous duplex ultrasound; US, ultrasound

2.3 | Plasma extracellular vesicle tissue factor activity assay

Plasma ETF activity was measured as previously described.³¹

2.4 | Plasma D-dimer

Plasma D-dimer levels were measured using ELISA kits (Abcam, Cambridge, MA, USA).

2.5 | Statistical methods

The Shapiro-Wilk test was used for assessment of normality. For the 2-group comparisons, the paired 2-tailed Student's *t*-test or the Wilcoxon signed-rank test was used, depending on the data distribution. For the 3-group comparisons, the Kruskal-Wallis test with Dunn's multiple comparison was used. To test the correlation between EVTF activity and D-dimer, Spearman's rank correlation coefficient was used. These statistical analyses were performed with Prism version 7.03 (GraphPad Software, La Jolla, CA, USA).

3 | RESULTS

3.1 | Patient characteristics

Our goal was to recruit 100 patients with PDAC and 100 patients with CRC. Once the necessary sample size was calculated, we performed a feasibility analysis prior to conducting the study. A total of 95 new patients with advanced pancreatic cancer and 154 new patients with advanced colorectal cancer were evaluated among the 3 primary enrollment centers in 2006. Thus, it was deemed feasible to enroll 25 patients each with pancreatic and colorectal cancer per year (total of 100 each over 4 years), accounting for ineligibility and lack of interest and allowing for loss to follow-up. Despite these calculations, we failed to meet enrollment goals in spite of opening the trial at an additional center. In fact, we enrolled only 13 patients with PDAC and 22 patients with CRC in the period between 2009 and 2013. The main reason for this was competing clinical trials evaluating different therapeutic agents/combinations that were targeting the same patient population, and which were prioritized over our observational study. Therefore, the study is underpowered for determining associations between EVTF activity and VTE.

Patient demographics are summarized in Table 1. The mean ages of the PDAC and CRC groups were 71 and 63, respectively. Subjects were predominantly male in the PDAC group. The majority of the patients in the PDAC group received gemcitabine-based treatment regimens (9/13), and the majority of the CRC group were treated with FOLFOX or another 5-fluorouracil-based regimen (20/22) (Table 2).

TABLE 1 Patient characteristics

| | Pancreatic cancer | Colorectal cancer |
|------------------|---------------------------|---------------------------------|
| Number | 13 | 22 |
| Mean age (range) | 71 (54-86) | 63 (46-92) |
| Sex | 9 male, 4 female | 11 male, 11 female |
| Race | 9 white, 3 black, 1 Asian | 13 white, 9 black |
| VTE events | 1 DVT | 1PE, 2 DVT, 1 Catheter thrombus |
| Number of death | 2 on study | 0 |

DVT, deep vein thrombosis; PE, pulmonary embolism; VTE, venous thromboembolism.

We observed 1 VTE in the pancreatic cancer group (PDAC8) (event rate of 7.7%). This patient developed a right upper extremity DVT 12 days after initiation of therapy. He developed progressive disease and died 35 days after initiation of therapy, having received only 1 cycle of chemotherapy. Four VTEs (CRC1, CRC5, CRC12, and CRC19) were recorded in the colorectal cancer group (event rate of 18.1%), including 1 PE (CRC1, day 54), 1 symptomatic DVT (CRC5 on day 20), 1 catheter-associated upper extremity thrombus (CRC12 on day 36), and 1 asymptomatic DVT (CRC19 on day 85 CUS).

There were 2 deaths during the 85-day study period. Both subjects (PDAC8, day 35; and PDAC10, day 34) had advanced pancreatic cancer and died within 5 weeks after initiation of chemotherapy from progressive disease. No arterial events were observed in either group.

3.2 | EVTF activity

Two of the patients with PDAC (PDAC8 and PDAC10) had elevated levels of EVTF activity at baseline (Table 2). In contrast, none of the patients with CRC had elevated levels of EVTF activity at baseline or during the study (Table 2 and Figures 2 and 3).

There was a trend toward decreased levels of EVTF activity after chemotherapy (Figure 2). We observed a decrease in EVTF activity 1 hour after chemotherapy in the 2 patients with PDAC with a high level of EVTF activity, but the number is too small for statistical analysis (Figure 2A). Chemotherapy significantly decreased EVTF activity in patients with CRC at cycle 5, but the values were below the baseline level of EVTF activity (Figure 2B).

PDAC8 had the highest level of EVTF activity at entry and exhibited an even higher level 4 days prior to the development of a DVT (Figure 3). PDAC10 had the second-highest level of EVTF activity at entry (Figure 3). Both PDAC8 and PDAC10 died of progressive disease at day 35 and day 34, respectively. EVTF activity was not increased in any of the colorectal cancer group, regardless of whether VTE ensued (Figure 3).

TABLE 2 Khorana Score, D-dimer, EVTF activity, VTE, and death in patients with pancreatic and colorectal cancer

| Patient | Khorana score | D-dimer (ng/mL) | EVTF (pg/mL) | VTE | Death | Treatment |
|-------------------|---------------|-----------------|--------------|---------|---------|--|
| Pancreatic cancer | | | | | | |
| PDAC1 | 2 | 0.90 | 0.10 | N | N | Gemcitabine, nab-paclitaxel, erlotinib |
| PDAC2 | 2 | 0.62 | 0.08 | N | N | Gemcitabine |
| PDAC3 | 2 | 1.31 | 0.32 | N | N | 5-FU and RT |
| PDAC4 | 2 | 0.80 | 0.16 | N | N | FOLFIRINOX then capecitabine |
| PDAC5 | 3 (EPO) | 0.74 | 0.06 | N | N | Gemcitabine |
| PDAC6 | 2 | 0.74 | 0.16 | N | N | Gemcitabine |
| PDAC7 | 2 | 1.12 | 0.01 | N | N | Gemcitabine |
| PDAC8 | 4 (Hgb, WBC) | 36.42 | 1.23 | Y (d12) | Y (d35) | Gemcitabine |
| PDAC9 | 2 | 2.24 | 0.39 | N | N | FOLFIRINOX |
| PDAC10 | 4 (Hgb, WBC) | 12.34 | 0.94 | N | Y (d34) | Gemcitabine |
| PDAC11 | 2 | 0.85 | - | N | N | FOLFOX |
| PDAC12 | 2 | 0.76 | 0.03 | N | N | Gemcitabine |
| PDAC13 | 2 | 0.96 | 0.02 | N | N | Gemcitabine |
| Colorectal cancer | | | | | | |
| CRC1 | 0 | 7.07 | 0.11 | Y (d54) | N | FOLFOX |
| CRC2 | 1 (Hgb) | 5.45 | 0.05 | N | N | FOLFOX |
| CRC3 | 1 (Plts) | 0.85 | 0.06 | N | N | FOLFOX |
| CRC4 | 0 | 5.15 | 0.03 | N | N | 5-FU, irinotecan and oxaliplatin |
| CRC5 | 0 | 1.93 | 0.01 | Y (d20) | N | FOLFOX |
| CRC6 | 2 (Hgb, Plts) | 1.34 | 0.02 | N | N | FOLFOX |
| CRC7 | 0 | 2.92 | 0.00 | N | N | FOLFOX |
| CRC8 | 1 (BMI) | 0.42 | 0.15 | N | N | FOLFOX |
| CRC9 | 1 (BMI) | 0.25 | 0.00 | N | N | FOLFOX |
| CRC10 | 1 (EPO) | 1.24 | 0.01 | N | N | FOLFOX + panitumumab |
| CRC11 | 1 (Plts) | 0.12 | 0.12 | N | N | FOLFOX then dropped oxaliplatin last cycle |
| CRC12 | 0 | 0.22 | 0.01 | Y (d36) | N | FOLFOX + bevacizumab |
| CRC13 | 0 | 0.19 | 0.03 | N | N | FOLFOX |
| CRC14 | 0 | 0.40 | 0.37 | N | N | FOLFOX |
| CRC15 | 1 (Hgb) | 2.96 | 0.07 | N | N | FOLFOX + bevacizumab |
| CRC16 | 0 | 0.03 | 0.07 | N | N | 5-FU + oxaliplatin then adding leucovorin |
| CRC17 | 0 | 1.51 | 0.03 | N | N | FOLFOX |
| CRC18 | 1 (Plts) | 4.02 | 0.08 | N | N | FOLFOX |
| CRC19 | 0 | 0.03 | 0.01 | Y (d85) | N | FOLFOX |
| CRC20 | 0 | 3.63 | 0.00 | N | N | FOLFOX |
| CRC21 | 0 | 2.43 | 0.14 | N | N | Oxaliplatin + capecitabine |
| CRC22 | 0 | 0.43 | 0.00 | N | N | 5-FU + bevacizumab +leucovorin |

5-FU, 5 fluorouracil; BMI, body mass index; CRC, colorectal cancer; EPO, erythropoietin; EVTF, extracellular vesicle tissue factor; Hgb, hemoglobin; N, no; PDAC, pancreatic ductal adenocarcinoma; plts, platelets; VTE, venous thromboembolism; WBC, white blood cell; Y, yes.

FIGURE 2 Effect of chemotherapy on levels of plasma extracellular vesicle tissue factor (EVTF) activity in pancreatic and colorectal cancer patients. EVTF activity is shown for patients with pancreatic cancer (PDAC) before (1) and 1 hour after (2P) in cycle 1 ($n = 12$), as well as before (43) and 1 hour (44P) after chemotherapy in cycle 3 ($n = 8$). The dashed line indicates the upper limit of healthy individuals

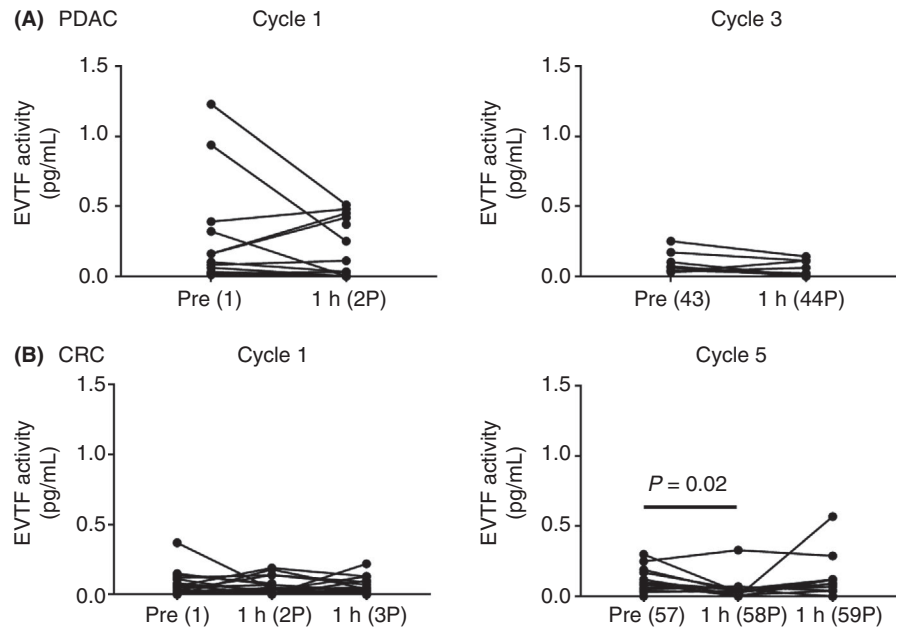

FIGURE 3 Time course of plasma extracellular vesicle tissue factor (EVTF) activity in patients with pancreatic (A) and colorectal cancer (B). EVTF activity is shown for patients with pancreatic (PDAC) and colorectal (CRC) cancer. Patients with venous thromboembolism (VTE) (1 in the pancreatic group and 4 in the CRC group) are shown in red. The timing of VTE occurrences are shown

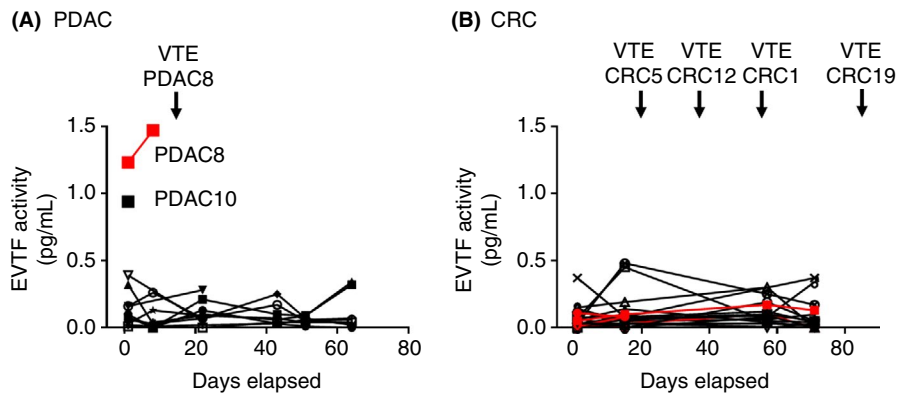
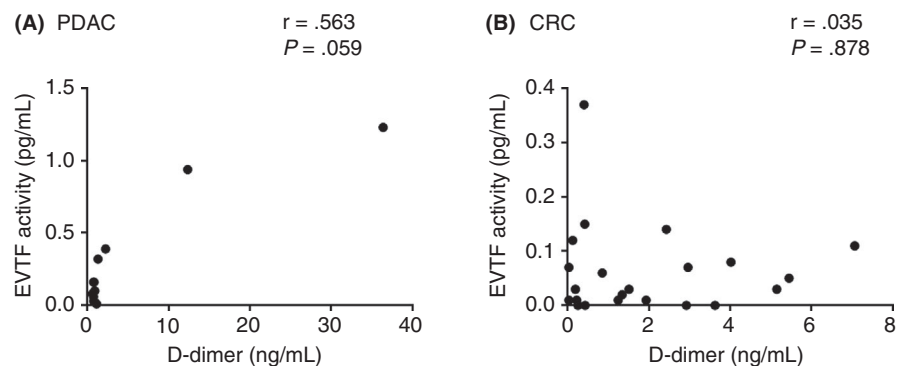

FIGURE 4 Correlation between plasma extracellular vesicle tissue factor (EVTF) activity and D-dimer in patients with pancreatic (A) and colorectal cancer (B). EVTF activity and D-dimer are shown for patients with pancreatic (PDAC) and colorectal (CRC) cancer at baseline



3.3 | Comparison of the levels of EVTF activity and D-dimer

We observed a borderline significant correlation between EVTF activity and D-dimer in the patients with PDAC ($r = 0.563$, $P = 0.059$) but not patients with CRC ($r = 0.035$, $P = 0.878$) (Figure 4). Patients with CRC who developed a VTE did not have significantly higher levels of D-dimer compared with those without VTE (2.31 ± 3.29 vs 1.85 ± 1.78 , mean \pm SD, $P = 0.78$).

3.4 | Comparison of the EVTF activity and the Khorana score

The Khorana score divides patients into 3 categories: low risk (score = 0), intermediate risk (score 1-2), and high risk (score ≥ 3). We calculated the Khorana score for all study patients at baseline (Table 2). Among the pancreatic cancer group, 3 patients had a high-risk score ≥ 3 . PDAC8 had an elevated white blood cell count and low hemoglobin. This patient also had elevated levels of EVTF

activity and D-dimer and died during the study. PDAC10 also had an elevated white blood cell count and low hemoglobin. This patient had elevated EVTF activity and D-dimer and died during the study. PDAC5 received erythropoietin but did not have elevated EVTF activity or D-dimer and survived to study completion. Among the colorectal cancer group, no patients had a high-risk Khorana score (Table 2).

4 | DISCUSSION

We examined the effect of chemotherapy on EVTF activity in patients with PDAC and CRC. In addition, we determined the association between EVTF activity and either VTE or survival in a longitudinal study. We recruited only 17% of the target number of patients, so the study is underpowered. However, we observed that chemotherapy decreased EVTF activity and EVTF activity was associated with VTE and death in patients with PDAC but not patients with CRC. There was a borderline association between EVTF activity and D-dimer in the patients with PDAC but not the patients with CRC.

Despite a careful feasibility analysis of the number of patients with pancreatic and colorectal cancer seen at the 3 enrollment sites and the addition of a fourth site, we had difficulty recruiting patients for this prospective, observational study. We found that the majority of patients were enrolled in competing clinical trials evaluating different therapeutic agents/combinations that were targeting the same patient population, and a low priority was given to our observational study.

We hypothesized that administration of chemotherapy would increase levels of EVTF activity due to death of TF-positive tumor cells. However, there was a trend toward lower levels of EVTF activity after chemotherapy. Indeed, EVTF activity was reduced 1 hour after chemotherapy in the 2 patients with PDAC with high levels of EVTF activity. Two previous studies have analyzed the effect of chemotherapy on circulating EVTF activity. A study with testicular cancer observed no change in EVTF activity, whereas another found that chemotherapy decreased EVTF activity.^{21,22} It is possible that chemotherapy increases the clearance of EVs by activating the endothelium. Indeed, the endothelium expresses developmental endothelium locus 1 that has been shown to clear circulating platelet-derived EVs.³²

Prospective single time point studies and a longitudinal study indicate that EVTF activity is associated with VTE in pancreatic cancer but not other types of cancer, including CRC.²²⁻²⁸ Our small study supports this conclusion, since we observed a time-dependent increase in EVTF activity prior to a VTE in patients with PDAC but no increase in EVTF activity in 4 patients with CRC who had a VTE. EVTF activity is also associated with decreased survival in patients with cancer.^{24,25,27,33} Similarly, we found that the 2 patients with PDAC who died had a high level of EVTF activity. These multiple observations suggest that EVTF activity may be a biomarker of cancer progression.

Patients with cancer are often prothrombotic and have elevated levels of D-dimer. Indeed, D-dimer improved the predictive

value of the Khorana score, and D-dimer is 1 of 2 parameters in the Vienna risk assessment score for VTE in patients with cancer.^{16,17} We found a borderline significant correlation between EVTF and D-dimer in patients with PDAC but not patients with CRC. Our data are consistent with a previous study showing a correlation between EVTF activity and D-dimer in patients with pancreatic cancer ($r = 0.51$, $P < 0.001$) but not in patients with brain, stomach and colorectal cancer.²⁴ One might expect an association between EVTF activity and D-dimer because TF activates the coagulation cascade whereas D-dimer is a degradation product of fibrin.

Interestingly, the 2 patients with PDAC with a high level of EVTF activity had a high-risk Khorana score due to elevated white blood cells and low hemoglobin. Activated monocytes express TF expression that may contribute to the elevated levels of EVTF observed in these 2 patients with PDAC.³⁴

The strengths of our study are the collection of samples before and after chemotherapy, the longitudinal design, and the lessons learned about the difficulties of enrolling patients with cancer for an observational study. Longitudinal studies are superior to single time point studies because of the ability to observe changes over time, which facilitates identification of changes that precede development of adverse events. A weakness of the study is that we did not meet our targeted enrollment. Therefore, the study was underpowered to evaluate the stated outcomes because the number of patients with elevated levels of EVTF activity, VTE, and death was too small to allow statistical analysis to be performed.

5 | CONCLUSIONS

Our study reveals the difficulty in enrolling patients for an observational study. However, despite the limited number of samples, our data are consistent with other studies showing that chemotherapy decreases circulating EVTF activity and that EVTF activity is associated with VTE in patients with PDAC but not patients with CRC, is associated with death, and correlates with D-dimer. More studies are needed confirm these results.

RELATIONSHIP DISCLOSURE

The authors declare nothing to report.

ACKNOWLEDGMENTS

The authors thank Dr J. Thaler for helpful comments.

AUTHOR CONTRIBUTIONS

RK and NSK designed the research. RK, YH, and NM performed data analysis and prepared the figures and tables. AI performed experiment. RK, YH, and NM wrote the manuscript. AI and NSK edited the manuscript.

ORCID

Raj S. Kasthuri  <https://orcid.org/0000-0001-6672-3082>

Yohei Hisada  <https://orcid.org/0000-0001-9157-0524>

REFERENCES

1. Timp JF, Braekkan SK, Versteeg HH, Cannegieter SC. Epidemiology of cancer-associated venous thrombosis. *Blood*. 2013;122:1712–23.
2. Khorana AA, Francis CW, Culakova E, Lyman GH. Risk factors for chemotherapy-associated venous thromboembolism in a prospective observational study. *Cancer*. 2005;104:2822–9.
3. Heit JA, Silverstein MD, Mohr DN, Petterson TM, O'Fallon WM, Melton LJ 3rd. Risk factors for deep vein thrombosis and pulmonary embolism: a population-based case-control study. *Arch Intern Med*. 2000;160:809–15.
4. Blom JW, Vanderschoot JP, Oostindier MJ, Osanto S, van der Meer FJ, Rosendaal FR. Incidence of venous thrombosis in a large cohort of 66,329 cancer patients: results of a record linkage study. *J Thromb Haemost*. 2006;4:529–35.
5. Sorensen HT, Mellekjaer L, Olsen JH, Baron JA. Prognosis of cancers associated with venous thromboembolism. *N Engl J Med*. 2000;343:1846–50.
6. Chew HK, Wun T, Harvey D, Zhou H, White RH. Incidence of venous thromboembolism and its effect on survival among patients with common cancers. *Arch Intern Med*. 2006;166:458–64.
7. Ay C, Pabinger I, Cohen AT. Cancer-associated venous thromboembolism: burden, mechanisms, and management. *Thromb Haemost*. 2017;117:219–30.
8. Hisada Y, Geddings JE, Ay C, Mackman N. Venous thrombosis and cancer: from mouse models to clinical trials. *J Thromb Haemost*. 2015;13:1372–82.
9. Walker AJ, Card TR, West J, Crooks C, Grainge MJ. Incidence of venous thromboembolism in patients with cancer - a cohort study using linked United Kingdom databases. *Eur J Cancer*. 2013;49:1404–13.
10. Khorana AA, Dalal M, Lin J, Connolly GC. Incidence and predictors of venous thromboembolism (VTE) among ambulatory high-risk cancer patients undergoing chemotherapy in the United States. *Cancer*. 2013;119:648–55.
11. Horsted F, West J, Grainge MJ. Risk of venous thromboembolism in patients with cancer: a systematic review and meta-analysis. *PLoS Med*. 2012;9:e1001275.
12. Blom JW, Doggen CJ, Osanto S, Rosendaal FR. Malignancies, prothrombotic mutations, and the risk of venous thrombosis. *JAMA*. 2005;293:715–22.
13. Pabinger I, Thaler J, Ay C. Biomarkers for prediction of venous thromboembolism in cancer. *Blood*. 2013;122:2011–8.
14. Khorana AA, Kuderer NM, Culakova E, Lyman GH, Francis CW. Development and validation of a predictive model for chemotherapy-associated thrombosis. *Blood*. 2008;111:4902–7.
15. Ay C, Dunkler D, Marosi C, Chiriac AL, Vormittag R, Simanek R, et al. Prediction of venous thromboembolism in cancer patients. *Blood*. 2010;116:5377–82.
16. Munoz Martin AJ, Garcia Alfonso P, Ruperez Blanco AB, Perez Ramirez S, Blanco Codesido M, Martin JM. Incidence of venous thromboembolism (VTE) in ambulatory pancreatic cancer patients receiving chemotherapy and analysis of Khorana's predictive model. *Clin Transl Oncol*. 2014;16:927–30.
17. Pabinger I, van Es N, Heinze G, Posch F, Riedl J, Reitter EM, et al. A clinical prediction model for cancer-associated venous thromboembolism: a development and validation study in two independent prospective cohorts. *Lancet Haematol*. 2018;5:e289–e298.
18. Hisada Y, Mackman N. Cancer-associated pathways and biomarkers of venous thrombosis. *Blood*. 2017;130:1499–506.
19. Grover SP, Mackman N. Tissue factor: an essential mediator of hemostasis and trigger of thrombosis. *Arterioscler Thromb Vasc Biol*. 2018;38:709–25.
20. Geddings JE, Mackman N. Tumor-derived tissue factor-positive microparticles and venous thrombosis in cancer patients. *Blood*. 2013;122:1873–80.
21. van den Hengel LG, van Steijn-van Tol AQ, Bertina RM, Versteeg HH, Osanto S. Microparticle-associated tissue factor activity in plasma is unaffected by cytolytic chemotherapy treatment in metastatic testicular cancer patients. *Thromb Res*. 2013;131:187–9.
22. Auwerda JJ, Yuana Y, Osanto S, de Maat MP, Sonneveld P, Bertina RM, et al. Microparticle-associated tissue factor activity and venous thrombosis in multiple myeloma. *Thromb Haemost*. 2011;105:14–20.
23. Khorana AA, Francis CW, Menzies KE, Wang JG, Hyrien O, Hathcock J, et al. Plasma tissue factor may be predictive of venous thromboembolism in pancreatic cancer. *J Thromb Haemost*. 2008;6:1983–5.
24. Thaler J, Ay C, Mackman N, Bertina RM, Kaider A, Marosi C, et al. Microparticle-associated tissue factor activity, venous thromboembolism and mortality in pancreatic, gastric, colorectal and brain cancer patients. *J Thromb Haemost*. 2012;10:1363–70.
25. Bharthuar A, Khorana AA, Hutson A, Wang JG, Key NS, Mackman N, et al. Circulating microparticle tissue factor, thromboembolism and survival in pancreaticobiliary cancers. *Thromb Res*. 2013;132:180–4.
26. Woei AJFJ, Tesselar ME, Garcia Rodriguez P, Romijn FP, Bertina RM, Osanto S. Tissue factor-bearing microparticles and CA19.9: two players in pancreatic cancer-associated thrombosis? *Br J Cancer*. 2016;115:332–8.
27. Hernandez C, Orbe J, Roncal C, Alvarez-Hernandez M, Martinez de Lizarrondo S, Alves MT, et al. Tissue factor expressed by microparticles is associated with mortality but not with thrombosis in cancer patients. *Thromb Haemost*. 2013;110:598–608.
28. Cohen JG, Prendergast E, Geddings JE, Walts AE, Agadjanian H, Hisada Y, et al. Evaluation of venous thrombosis and tissue factor in epithelial ovarian cancer. *Gynecol Oncol*. 2017;146:146–52.
29. Giordano P, Molinari AC, Del Vecchio GC, Saracco P, Russo G, Altomare M, et al. Prospective study of hemostatic alterations in children with acute lymphoblastic leukemia. *Am J Hematol*. 2010;85:325–30.
30. Reitter EM, Kaider A, Ay C, Quehenberger P, Marosi C, Zielinski C, et al. Longitudinal analysis of hemostasis biomarkers in cancer patients during antitumor treatment. *J Thromb Haemost*. 2016;14:294–305.
31. Hisada Y, Mackman N. Measurement of tissue factor activity in extracellular vesicles from human plasma samples. *Res Pract Thromb Haemost*. 2019;3:44–8.
32. Dasgupta SK, Le A, Chavakis T, Rumbaut RE, Thiagarajan P. Developmental endothelial locus-1 (Del-1) mediates clearance of platelet microparticles by the endothelium. *Circulation*. 2012;125:1664–72.
33. Hisada Y, Thal C, Lundstrom S, Wallen H, Mackman N. Comparison of microvesicle tissue factor activity in non-cancer severely ill patients and cancer patients. *Thromb Res*. 2018;165:1–5.
34. Steinemann S, Ulevitch RJ, Mackman N. Role of the lipopolysaccharide (LPS)-binding protein/CD14 pathway in LPS induction of tissue factor expression in monocytic cells. *Arterioscler Thromb*. 1994;14:1202–9.

How to cite this article: Kasthuri RS, Hisada Y, Ilich A, Key NS, Mackman N. Effect of chemotherapy and longitudinal analysis of circulating extracellular vesicle tissue factor activity in patients with pancreatic and colorectal cancer. *Res Pract Thromb Haemost*. 2020;4:636–643. <https://doi.org/10.1002/rth2.12317>