



# A Case Report of Genetic Cascade Screening in Dilated Cardiomyopathy: A Perspective for Preventive Cardiology

**Zeinab Barati**<sup>1,2,3</sup>, **Dariush Farhoud**<sup>4,5</sup>, **Uwe Nixdorff**<sup>6</sup>,  
**Mohammadreza Mohammadhasani**<sup>2</sup>, **\*Maryam Eslami**<sup>2,7</sup>, **Karim Nayernia**<sup>8</sup>

1. Fetal Health Research Center, Hope Generation Foundation, Tehran, Iran
2. Applied Biotechnology Research Center, Tehran Medical Sciences, Islamic Azad University, Tehran, Iran
3. Faculty of Mathematics and Natural Sciences, University of Cologne, Cologne, Germany
4. Farhud Genetic Clinic, Tehran, Iran
5. Department of Basic Sciences/Ethics, Iranian Academy of Medical Sciences, Tehran, Iran
6. European Prevention Center, Düsseldorf, Germany
7. Department of Genetics, Faculty of Advanced Sciences & Technology, Tehran Medical Sciences, Islamic Azad University, Tehran, Iran
8. European Center for Personalized Medicine, Düsseldorf, Germany

**\*Corresponding Author:** Email: maryam.eslami2010@gmail.com

(Received 12 Jan 2021; accepted 11 Mar 2021)

## Abstract

Cardiomyopathies are heterogeneous and critical disorders of cardiovascular diseases. One of the most common inherited cardiomyopathies is DCM (dilated cardiomyopathy). Genetic disorders are found in approximately 50% of DCM cases. We aimed to describe a case of DCM in a 42-year-old woman in 2018 at Farhud Genetic Clinic, Tehran, Iran. To detect genetic involvement, Next-generation sequencing (NGS) was performed and the data were evaluated carefully. Variations in different genes coding crucial proteins in cardiac muscle structure (i.e. *Titin*, *Obscurin*, *MYH6*, and *LAM44*) and proteins involved in channels (i.e. *CAVNA1C*, *SCN1B* and *SCN5A*) were detected by whole-exome sequencing (WES). In agreement with the clinical manifestations and molecular analysis, DCM was confirmed. This study provides further evidence on the diagnostic role of NGS in borderline DCM cases. It also shows the recently developed high throughput sequencing can provide clinicians with this approach to diagnosis, treatment, and prevention of such hard-to-diagnose disorders. Furthermore, this study highlights the basis of personalized medicine, namely detection of high-risk individuals by revealing some genetic variants as predictive risk factors, and initial prevention of DCM.

**Keywords:** Next-generation sequencing; Cardiomyopathies; Personalized medicine; Molecular targeted therapy

## Introduction

Cardiomyopathies are a heterogeneous and critical category of heart disorders (1). One of the most common inherited cardiomyopathies is dilated

cardiomyopathy (DCM)(1). DCM (1) is a myocardial disorder that enlarges and weakens ventricular chambers and results in systolic dysfunction that



can lead to progressive heart failure, supraventricular and ventricular arrhythmias, and thromboembolism (2). Genetic forms of DCM account for approximately 50% of cases. Involved genes provide instructions for making proteins found in the sarcomere, cytoskeleton, nuclear envelope, sarcolemma, ion channels, and intercellular junctions. It is likely that specific mutations of these genes impair different pathways and disrupt various structures and mechanisms in the myocardium (3).

In this study, we report several genes involved in cardiomyopathy in an affected woman and also discuss the genes involved in the pathogenesis of cardiomyopathy in this case. Whole-exome sequencing (WES) followed by a comprehensive stepwise variant analysis has been applied to explore the underlying genetic cause of such heart disorder in the proband and her offspring.

## Case Report

The mentioned proband (Fig. 1, individual III-1), was referred for genetic counseling to Farhud Genetic Clinic, Tehran, Iran in 2018 with a presumptive diagnosis of familial DCM.

The patient was a 42-year-old woman with heart disease; symptomatic for 4 years with episodes of palpitation that occasionally led to chest tightness, anxiety, fatigue, and also recent exertional syncope. During initial workup, TTE (transthoracic echocardiogram) revealed left-side heart failure (ejection fraction 25%), and ECG holter monitoring showed sinus rhythm and occasional VPB (ventricular premature beats) bigeminy. In an attempt to further characterize the disease and find the etiology, no valvular disease was detected and cardiac MRI (magnetic resonance imaging) CMR (cardiovascular magnetic resonance imaging) suggested IDCM (Idiopathic Dilated CardioMyopathy), LLC (Lake Louise Criteria); the thallium myocardium perfusion scan was also unremarkable except for mild ischemia in a midventricular segment of anterior wall. The patient received an implantable cardioverter-defibrillator (ICD) implantation as secondary prevention for life-threatening

arrhythmia (after a VT attack). The patient's family history included her father who died at the age of 49, a year after heart transplantation surgery; his heart condition had a similar clinical picture as the proband. Other affected family members shown in the pedigree had cardiac disorders not well characterized before death (Fig.1). To date, the offspring's clinical screening for evidence of DCM has been negative despite detecting some genetic variants related to DCM.

The family's pedigree suggested an autosomal dominant pattern of inheritance for DCM with 50% recurrence risk. After several comprehensive counseling sessions, drawbacks, and benefits of all possible genetic investigations were thoroughly discussed.

Besides, written informed consents were then obtained in the pretest counseling session.

WES was performed on the DNA sample of the proband for genetic investigation. Various steps of exome sequencing were all performed by the manufacturer guidelines: sample preparation, library construction, template preparation, and high-throughput sequencing based on Illumine Rapid Capture Enrichment guide 0913. Genetic defects and causative mutations in diseases with heterogeneity were identified by bioinformatics analysis. Moreover, de novo single nucleotide variants that may substantially contribute to other health issues were also studied. Point mutation, micro insertion, deletions, and duplication (<20 base pair) were also detected. Further WES analysis was performed on the DNA sample of the offspring of the family who was at the risk of cardiomyopathy, DCM.

Various variations in different genes coding crucial proteins in cardiac muscle structure like *Titin*, *Obscurin*, *MYH6*, *LAMA4*, and proteins involved in channels such as *CAVNA1C*, *SCN1B*, and *SCN5A*, were detected by WES. On the other hand, further WES analysis showed some variants in the same genes in the proband's offspring (individuals IV-1 and IV-2 aged 16 and 12 yr old respectively) Table 1.

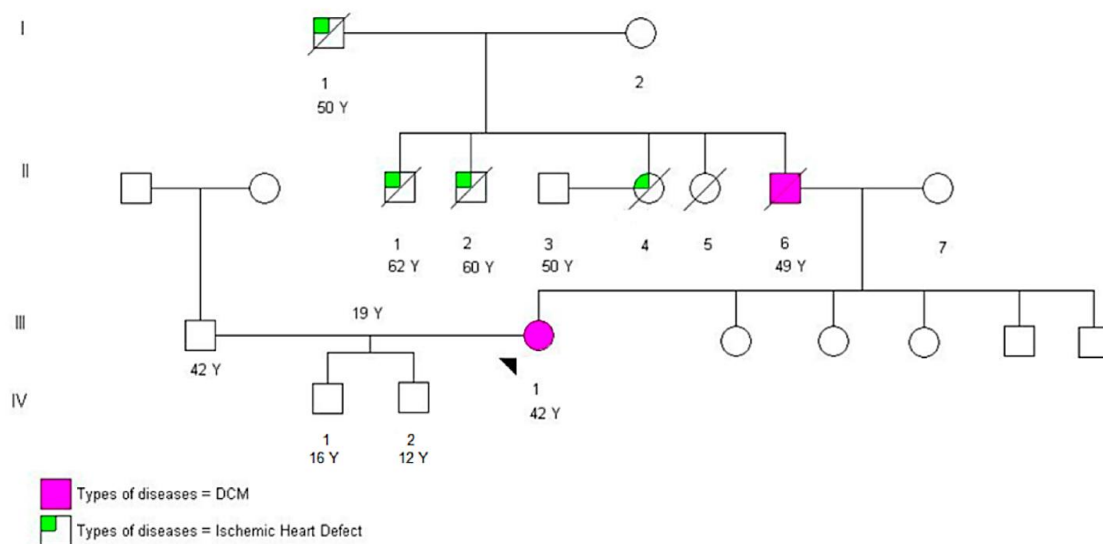

Fig. 1: Family pedigree. Arrow head denotes the proband

Table 1: List of detected variants in 6 genes associated with genetic heart disorders in the proband and her offspring

No	GENE	VARIANT	p.	c.	Clinical significance	MOTHER	BEHNAM (SON 1)	MI-LAD (SON 2)
1	TNNT2	rs3729547	(p.Ile116=)	c.348C>T	Benign/Likely benign	+Hetero	+Hetero	+Hetero
2	TPM1	rs1071646	(p.Ala151=)	c.453C>A	Benign	+ Hetero	+ Hetero	- Not detected
3	MYH6	rs365990	p.(Val1101Ala)	c.3302T>C	Benign	+ Hetero	+ Hetero	- Not detected
4	SCN5A	rs1805124	p.(His558Arg)	c.1673A>G	Benign/Likely benign	++ Homo	++ Homo	+ Hetero
5	RBM20	rs35141404	p.(=)	c.90G>A	Benign	+ Hetero	++ Homo	+ Hetero
6	RBM20	rs1417635 NM_001134363.3	p.(Ser768*)	c.2303C>A	Benign	+ Hetero	+ Hetero	+ Hetero
7	KCNE1	rs1805127	p.(Ser38Gly)	c.112A>G	Benign	+ Hetero	+ Hetero	+ Hetero

## Discussion

In this study, a comprehensive genetic approach, WES, was carried out to identify genetic variations associated with inherited cardiomyopathies, particularly DCM, which is genetically heterogeneous. DCM is usually associated with rare mutations in a large number of genes. Delineation of the molecular causes of DCM and accurate identification of relatives who are at-risk and unaffected mutation carriers is the aim of this study. This study also provides further evidence of the role of personalized medicine which enables us to detect some genetic variants that might be considered risk factors for development of the disease in asymptomatic relatives of patients with DCM.

Some mutual genetic variations in six genes are detected in the proband and offspring. Each mutual gene's function and related studies are discussed below.

Mutations in *TNNT2* are potentially related to severe forms of cardiomyopathies (4). rs3729547 is an SNP (Single nucleotide polymorphism) that was recently considered to be mildly associated with DCM in the Han Chinese population and Hypertrophic cardiomyopathy (HCM) in Indian population (4). This SNP was detected in the proband and both at-risk sons.

The close relationship of SNPs with DCM was shown in two screenings in Europe (5). rs1071646, an SNP in the *TPM1* gene, might be a risk factor for affected people with DCM in the Kazakh population. A highly conserved group of genes encodes a family of actin-binding proteins known as Tropo Myosins. There are four tropomyosin-encoding genes: *TPM1*, *TPM2*, *TPM3*, and *TPM4* in humans. *TPM1* is the most functional and encodes different tissue-specific isoforms (6). Mutations in tropomyosin can have adverse effects on striated muscle function. In humans, various mutations in *TPM1* have been associated with familial HCM and DCM (7). This SNP is detected in the proband and only one of the sons is at a higher risk.

rs365990 is an SNP located in exon 25 of the *MYH6* gene. This gene provides instructions for alpha myosin heavy chain (alpha-MyHC), a part of

a larger protein called type II myosin which is a molecular motor of muscle. Mutations in this gene can lead to a spectrum of cardiac disorders including HCM and DCM. As all *MYH6* mutations were located in highly conserved residues, structural or chemical bonds of MyHC are expected to change (8). Moreover, according to a study by deCODE Genetics (deCODE genetics, Inc. Reykjavík, Iceland) rs365990 was significantly associated with heart rate and PR interval. A significant correlation between rs365990 and heart rate and PR interval was reported.

rs1805124 is an SNP located in the *SCN5A* gene. This gene provides instructions for a subunit of the voltage-gated sodium channel, responsible for maintaining the normal function of inward sodium current. Mutations in the *SCN5A* gene have been found to cause a variety of cardiac diseases (9). The flow of positively charged sodium atoms (sodium ions) into cells is controlled by opening and closing these channels. The sodium channels containing proteins produced from the *SCN5A* gene are abundant in the cardiac cells and play a critical role in the ability of these cells to generate and transmit electrical signals. The association between familial DCM and the rs1805124 polymorphism in the *SCN5A* gene has been previously reported (9) rs35141404 and rs1417635 are SNP located in *RBM20*. This gene encodes RNA binding motif protein 20 that binds RNA and regulates splicing. It is expressed mostly in striated muscle and cardiac muscle tissue. The *RBM20* mutation was previously reported in familial DCM (10). rs1805157 is an SNP in *KCNE1*. This gene encodes a protein with an ability to manage and control the activity of potassium channels. These channels pass millions of positively charged potassium atoms (ions) per second across the membrane opening and shutting their gates in milliseconds by changes in voltage concentration. This ability plays a critical role in the cell's ability to generate and transmit electrical signals (11).

*LMNA* (*lamin A/C*) is one of the most commonly identified pathogenic genes in DCM. This gene provides instructions for making protein products including lamin A and C, which are the main cytoskeleton protein for maintaining normal nuclear

membrane morphology (12). Despite the fact of association between 200 *LMNA* mutations and progress of DCM with variable involvement of skeletal muscle (13), no mutation was identified in *LMNA* in the proband. Based on the detected variants, both sons of the proband are at the risk for cardiomyopathy; however, for one of them, a higher risk is expected.

Management of DCM varies depending on the severity of the damage to the disease and the patient's symptoms. Once diagnosed, the primary aim is to improve cardiac function and reduce symptoms and also prevent further damage. The last choice for patients who are resistant to medical strategies is heart transplantation (14). After comprehensive genetic study, ICD was suggested to prevent sudden cardiac death in the proband. Management of asymptomatic mutated patients and mutation carriers is also a matter of importance. NGS technologies and advanced molecular techniques revolutionized gene screening studies and brought fresh perspectives on DCM genetics. Moreover, discovering the underlying molecular causes can influence treatment decisions. There are several vital examples of *LMNA* and *SCN5A* gene mutations, where clinical management decisions can directly be affected by knowing a patient's genotype (15). Genetic testing can be carried out quickly in suspected *LMNA* carriers and these individuals may benefit from prophylactic implantable cardioverter-defibrillator devices and early heart transplantation. Moreover, in some families, p.R222Q variant in *SCN5A* was detected related to a particularly extreme form of arrhythmic DCM. Medications with sodium channel-blocking actions have been discovered to adequately improve ventricular contractile function and decrease arrhythmic burden in affected family members.

The importance of practical genomics has been highlighted in this recurrent treatable variant, indicating that personalized medicine-based therapies are possible (15). Moreover, in particular, individual genetic makeup can also be useful for selection of appropriate medicine doses. In many cases, detrimental side effects and inadequate drug effects can be predicted by detection of genetic variants

that modify drug concentrations (pharmacokinetics) or responsiveness (pharmacodynamics) (15). The future of personalized DCM care will be depicted through the following steps: identification of high-risk individuals by genotyping and considering environmental risk factors, followed by profound phenotyping and clinical examination to detect and monitor myocardial dysfunction and abnormalities and finally finding the right time to start the most appropriate management (15).

## Conclusion

DCM is highly suggested based on molecular study of a large number of mutated genes and clinical manifestations in the affected family members. Further Sanger verification is indicated for all mutations associated with pathogenic signs and symptoms. Moreover, this study provided further evidence on the crucial role of NGS technique in characterizing such heterogeneous disorders. Recently developed high throughput sequencing can provide clinicians with new devices for early diagnosis, targeted treatment, and prevention of such clinically silent disorders. The basis of personalized medicine, namely accurate identification of at-risk individuals enables convenient mediation that might affect the severe complications and mortality of this disease, is also emphasized in this study.

## Ethical considerations

Ethical issues (Including plagiarism, informed consent, misconduct, data fabrication and/or falsification, double publication and/or submission, redundancy, etc.) have been completely observed by the authors.

## Acknowledgements

We should thank the International Center for Düsseldorf Personalized Medicine Center and P7Medicine Partner Laboratories for their collaboration.

## Conflict of interest

The authors declare that there is no conflict of interests.

## References

1. Zhao Y, Feng Y, Zhang Y-M, et al (2015). Targeted next-generation sequencing of candidate genes reveals novel mutations in patients with dilated cardiomyopathy. *Int J Mol Med*, 36(6):1479–1486.
2. Maron BJ, Towbin JA, Thiene G, et al (2006). Contemporary definitions and classification of the cardiomyopathies: an American Heart Association Scientific Statement from the Council on Clinical Cardiology, Heart Failure and Transplantation Committee; Quality of Care and Outcomes Research and Functional Genomics and Translational Biology Interdisciplinary Working Groups; and Council on Epidemiology and Prevention. *Circulation*, 113(14):1807–16.
3. Mestroni L, Brun F, Spezzacatene A, et al (2014). Genetic Causes of Dilated Cardiomyopathy. *Prog Pediatr Cardiol*, 37(1–2):13–18.
4. Rani DS, Nallari P, Dhandapany PS, et al (2012). Cardiac Troponin T (TNNT2) mutations are less prevalent in Indian hypertrophic cardiomyopathy patients. *DNA Cell Biol*, 31(4):616–24.
5. Kimura A (2011). Contribution of Genetic Factors to the Pathogenesis of Dilated Cardiomyopathy. *Circulation Journal*, 75(7):1756–1765.
6. Denz CR, Narshi A, Zajdel RW, et al (2004). Expression of a novel cardiac-specific tropomyosin isoform in humans. *Biochem Biophys Res Commun*, 320(4):1291–7.
7. Henderson CA, Gomez CG, Novak SM, et al (2017). Overview of the Muscle Cytoskeleton. *Compr Physiol*, 18;7(3):891–944.
8. Carniel E, Taylor MRG, Sinagra G, et al (2005). Alpha-myosin heavy chain: a sarcomeric gene associated with dilated and hypertrophic phenotypes of cardiomyopathy. *Circulation*, 112(1):54–9.
9. Mazzaccara C, Limongelli G, Petretta M, et al (2018). A common polymorphism in the SCN5A gene is associated with dilated cardiomyopathy. *J Cardiovasc Med (Hagerstown)*, 19(7):344–350.
10. Long PA, Evans JM, Olson TM (2017). Diagnostic Yield of Whole Exome Sequencing in Pediatric Dilated Cardiomyopathy. *J Cardiovasc Dev Dis*, 4(3):11.
11. Dehghani-Samani A, Madreseh-Ghahfarokhi S, Dehghani-Samani A (2019). Mutations of Voltage-Gated Ionic Channels and Risk of Severe Cardiac Arrhythmias. *Acta Cardiol Sin*, 35(2):99–110.
12. Li YD, Ji YT, Zhou XH, et al (2015). Significance of sarcomere gene mutation in patients with dilated cardiomyopathy. *Genet Mol Res*, 22;14(3):11200–10.
13. Halliday BP, Cleland JGF, Goldberger JJ, et al (2017). Personalizing Risk Stratification for Sudden Death in Dilated Cardiomyopathy: The Past, Present, and Future. *Circulation*, 136(2):215–231.
14. Leonard RB, Schwartz E, Allen DA, et al (1992). Peripartum cardiomyopathy: a case report. *J Emerg Med*, 10(2):157–61.
15. Fatkin D, Huttner IG, Kovacic JC, et al (2019). Precision Medicine in the Management of Dilated Cardiomyopathy: JACC State-of-the-Art Review. *J Am Coll Cardiol*, 74(23):2921–2938.