

# The *Rhodomonas salina* mitochondrial genome: bacteria-like operons, compact gene arrangement and complex repeat region

Amy M. Hauth\*, Uwe G. Maier<sup>1</sup>, B. Franz Lang and Gertraud Burger

Département de Biochimie, Robert Cedergren Research Center for Bioinformatics and Genomics, Canadian Institute for Advanced Research, Université de Montréal, 2900 Boulevard Edouard-Montpetit, Montréal, Québec, Canada H3T 1J4 and <sup>1</sup>Cell Biology, Philipps-University Marburg, Karl-von-Frisch-Strasse, D35032 Marburg, Germany

Received June 29, 2005; Revised and Accepted July 21, 2005

DDBJ/EMBL/GenBank accession no. NC\_002572

## ABSTRACT

To gain insight into the mitochondrial genome structure and gene content of a putatively ancestral group of eukaryotes, the cryptophytes, we sequenced the complete mitochondrial DNA of *Rhodomonas salina*. The 48 063 bp circular-mapping molecule codes for 2 rRNAs, 27 tRNAs and 40 proteins including 23 components of oxidative phosphorylation, 15 ribosomal proteins and two subunits of *tat* translocase. One potential protein (ORF161) is without assigned function. Only two introns occur in the genome; both are present within *cox1* belong to group II and contain RT open reading frames. Primitive genome features include bacteria-like rRNAs and tRNAs, ribosomal protein genes organized in large clusters resembling bacterial operons and the presence of the otherwise rare genes such as *rps1* and *tatA*. The highly compact gene organization contrasts with the presence of a 4.7 kb long, repeat-containing intergenic region. Repeat motifs ~40–700 bp long occur up to 31 times, forming a complex repeat structure. Tandem repeats are the major arrangement but the region also includes a large, ~3 kb, inverted repeat and several potentially stable ~40–80 bp long hairpin structures. We provide evidence that the large repeat region is involved in replication and transcription initiation, predict a promoter motif that occurs in three locations and discuss two likely scenarios of how this highly structured repeat region might have evolved.

## INTRODUCTION

Mitochondrial DNAs (mtDNAs) of eukaryotes as diverse as mammals, yeasts and ciliates encode essentially the same biological functions. Components specified by mitochondrial genes are involved primarily in oxidative phosphorylation, protein synthesis and in some instances also in transcription, RNA processing, and the import, assembly and maturation of proteins [for a recent review see (1)]. The most conspicuous variation between mtDNA in eukaryotes is significant differences in gene complement, which ranges from as few as five in apicomplexan protists (2) to nearly a hundred in jakobid flagellates (3). Also noticeably, mtDNAs from various taxa have differences in coding density, i.e. the proportion of coding versus non-coding DNA. Highly compact mitochondrial genomes occur in animals [‘small is beautiful’ (4)], red algae (5), ciliates (6,7) and some fungi [e.g. *Schizosaccharomyces pombe* (8)], with the highest density found in the bicosoecid flagellate *Cafeteria roenbergensis* (9) where only 3.4% is non-coding. Lowest density occurs in land plants and many fungi as well as the unicellular relatives of animals, the choanozoan and ichthyosporean protists, where extensive intergenic regions account for 50–70% of the total mitochondrial genome [reviewed in (10)].

Recently, we discovered a ‘hybrid’ mtDNA genome in the sense that it has both a highly compact gene arrangement and a single extensive repeat region. This bi-partite structure occurs in the unicellular protist *Rhodomonas salina*, a cryptophyte alga. Cryptophytes (or cryptomonads) owe their name to the fact that their cells harbour remnants of a second eukaryote. The vestigial structures include a chloroplast and a small nucleus [nucleomorph (11,12)]. Molecular phylogenies indicate that cryptophytes are among the earliest-diverging and slowest-evolving eukaryotic lineages (13,14). Therefore, its

\*To whom correspondence should be addressed. Tel: +1 514 343 6111, ext. 2721; Fax: +1 514 343 2210; Email: amy.hauth@umontreal.ca

mtDNA might have maintained certain ancestral features that have been lost in other, more diverged species. Here, we report the mitochondrial genome organization of *R.salina*, including detailed analysis of its remarkable gene complement, its bacteria-like gene order and the unusual presence of a highly complex intergenic repeat region. Furthermore, we address how the repeat region might have emerged and which biological role it may play.

## MATERIALS AND METHODS

### Genome sequence techniques

*R.salina* [formerly *Pyrenomonas salina* (15)] obtained from CCAM (Culture Collection of Algae Marburg, <http://staff-www.uni-marburg.de/~cellbio/welcomeframe.html>) was grown on F/2 medium (for growth medium recipe, <http://megasun.bch.umontreal.ca/People/lang/FMGP/methods.html>) under permanent cool-white fluorescent light. When reaching the late logarithmic growth phase (after ~2 weeks), cells were harvested by centrifugation, and mtDNA was purified, mechanically sheared, cloned and sequenced essentially as described previously (16). The complete mtDNA sequence is available in GenBank (accession no. NC\_002572).

### Bioinformatics analysis

Individual direct and inverted repeats within the *R.salina* mtDNA genome were identified using TRIPLOTS (developed by A.H., <http://megasun.bch.umontreal.ca/People/ahauth/tools>). Complete analysis of the repetitive region required five different similarity measures using various window ( $w$ ) and maximum nucleotide mismatch ( $m$ ) combinations: (i)  $w = 70$ ,  $m = 20$ ; (ii)  $w = 50$ ,  $m = 15$ ; (iii)  $w = 20$ ,  $m = 2$ ; (iv)  $w = 15$ ,  $m = 1$ ; and (v)  $w = 10$ ,  $m = 0$ . Manual compilation combined individual measures to define the final structure of the repeat region.

For prediction of probable origin and terminus of replication, the cumulative GC skew technique was used that measures the asymmetric strand distribution of G and C for individual fixed-length windows along the sequence, i.e.  $(G-C)/(G+C)$ , and then sums the scores across the sequence [(17), <http://bioinformatics.upmc.edu/GCSkew.html>]. Cumulative scores plotted along the sequence indicate probable origin (local minimum) and terminus (local maximum) of replication.

For stem-loop structure prediction and calculation of minimum Gibbs free energies in DNA, we utilized mFold (18,19). All web analyses (<http://www.bioinfo.rpi.edu/applications/mfold/>) used default parameters that include a temperature of 37°C. Here, we considered only stem-loop structures predicted to have a  $\Delta G_{37}^{\circ} \leq -20$  kcal/mol, although numerous smaller and less stable structures occur in the analyzed repeat region as well.

Promoter search using the TRIPLOTS software mentioned above identified direct and inverted repeats between the region upstream of the rRNA cluster and within the repeat region centred around an 8 nt sequence, TAAAAAAT. Genome-wide analysis yielded numerous occurrences of this octamer (simple pattern search tool developed by A. Hauth, unpublished). Using the occurrences exclusively upstream of *rns*, the motif was expanded to the decamer TAAAAAATAT. Subsequent

observation noted a 13 nt TAAAAAATATGGT sequence in each of the three predicted promoter locations.

## RESULTS

### Physical properties, gene content and overall organization of *R.salina* mtDNA

The mtDNA of *R.salina* maps as a circular molecule of 48 063 bp; however, like that of most eukaryotes, it is probably organized in linear, multimeric concatamers (20–23). The genetic map (Figure 1) shows exceptionally dense packing of the 69 genes, 9 of which overlap by 1–39 bp. The two largest non-coding stretches of the genome are a 4.7 kb long region containing repeats (described in more detail below) and a 505 bp long region located between *rps19* and *cox1* without obvious structural features.

*R.salina* mtDNA codes for the small subunit (SSU) and large subunit (LSU) rRNAs, 27 transfer RNAs (tRNAs), and 40 proteins, including 18 components of the respiratory chain, 5 ATP synthase subunits, 15 ribosomal proteins and 2 subunits of the tat translocase. Intriguingly, two separate genes encode the Nad10 protein of *R.salina* (Figure 1); *nad10\_a* specifies a short N-terminal portion of the protein while the residual 9/10 is encoded by *nad10\_b*. We assume that the gene modules are transcribed and translated separately because there is no evidence for *trans*-splicing such as group II intron-like sequences adjacent to the gene modules (24).

Four classes of *R.salina* mitochondrial genes have counterparts in only a few other protist and plant taxa (Figure 1). First, the *tatA* gene (coding for a subunit of tat translocase) has been recognized so far only in jakobid mtDNAs (25). Second, *rpsI* has been found to date only in jakobids and malawimonads [for reviews see (26,27)]. Third, genes encoding certain subunits of NADH dehydrogenase subunits and ATPase (*nad8*, *nad10*, *nad11* and *atp1*) are rarely found in eukaryotes. Fourth, subunits of succinate:ubiquinone oxidoreductase (*shd3* and *shd4*) are present in only a few green algae and the liverwort *Marchantia polymorpha* (28–31), in several red algae (5,32–34) and in all jakobid flagellates including *Reclinomonas americana* (3,35).

### Vestiges of bacterial operon structures

Comparisons of mitochondrial gene order reveal vestiges of bacterial operon structure in *R.salina* (Figure 2). The ribosomal protein clusters *rps3-rpl16-rpl14-rpl5-rps14* and *rps8-rpl6-rps13-rps11* in *R.salina* mtDNA preserve the same relative gene order as in the adjacent S10, *spc*, and  $\alpha$  operons of *Escherichia coli*, which are also maintained with little variation in the gene-rich mtDNAs of several other protists and the land plant *M.polymorpha*. Other indications of operon-like regulation of protein expression are clusters of genes coding for subunits of the same enzyme complex (Figure 1). Note that the mitochondrial ribosomal protein clusters are highly reduced in the closest unicellular relative of animals [e.g. the choanoflagellate *Monosiga brevicollis* (10)] and that only a single gene (*rps3*) was retained in some but not all fungi (36).

### Mitochondrial rRNA and tRNA genes

The mitochondrial genome of *R.salina* encodes eubacteria-like LSU and SSU rRNAs. Their predicted sizes (2663 and



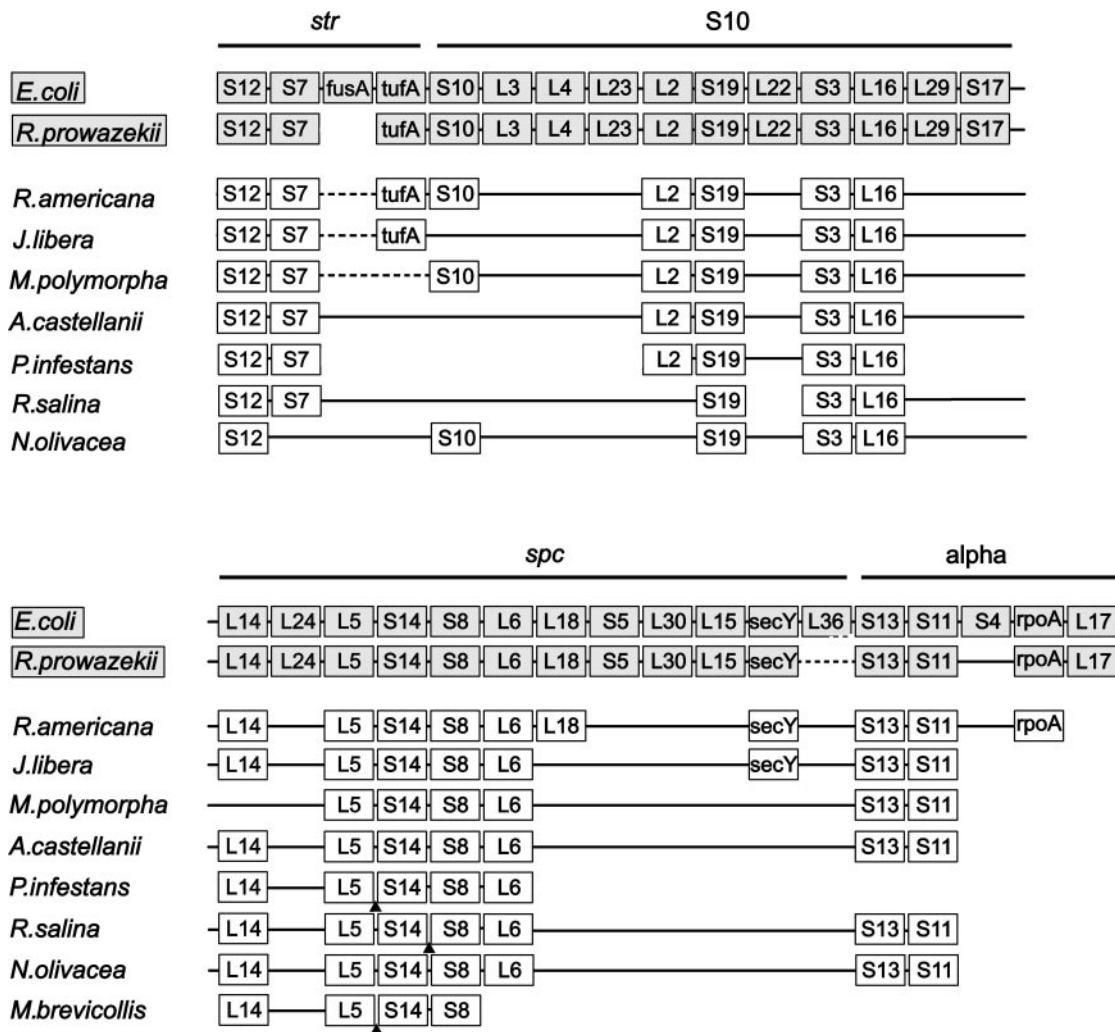

**Figure 2.** Conservation of ribosomal protein gene organization. Gene order found in mtDNAs is compared with that of the contiguous bacterial *str*, S10, *spc* and alpha operons of *E. coli* and *Rickettsia prowazekii*. Solid lines connect adjacent genes and insertion of several additional genes are indicated by triangles. Bacterial data (*E. coli*, *R. prowazekii*) are shaded. *E. coli* (accession no. NC\_000913); *R. prowazekii* (accession no. NC\_000963); *R. americana* (accession no. NC\_001823); *J. libera* (G. Burger, B. F. Lang and M. W. Gray, unpublished data); *M. polymorpha* (accession no. NC\_001660); *A. castellanii* (accession no. NC\_001637); *P. infestans* (accession no. NC\_002387); *R. salina* (this report, accession no. NC\_002572); *N. olivacea* (accession no. AF110138); *M. brevicollis* (accession no. NC\_004309). Data from *E. coli* were retrieved from NCBI's complete genome section. Data from *Rickettsia* and protists were retrieved from GOBASE (<http://megasun.bch.umontreal.ca/gobase>).

AUA-ile codons more efficiently than does tRNA<sup>Ile</sup>(CAU). Irrespective of the precise specificity of the *R. salina* tRNA<sup>Ile</sup>(UAU), similarity searches reveal a high degree of identity with mitochondrial tRNA<sup>Phe</sup> from both *R. salina* (Figure 3) and several other species. This is an apparent case of gene duplication followed by divergence of one of the copies to a different function, a mechanism, termed 'authenticity theft,' that was recently identified in sponge mtDNAs (40).

### Introns

Two introns of length 4091 and 2482 bp are inserted into the *R. salina* *coxI* gene. These introns belong to group II and harbour typical open reading frames (ORFs) of the so-called RT type (41), which are characterized by three distinctive protein domains: Reverse Transcriptase, maturase and a C-terminal DNA binding domain (42). Intron secondary

structures and ORFs are most similar to those of *coxI* introns in the brown alga *Pylaiella littoralis*, a class that is most widespread across mitochondria (43).

### Large, repeat-containing, intergenic region

The large, 4.7 kb-long, intergenic region in *R. salina* mtDNA consists predominantly of an elaborate, 4.5 kb repeat region. Our analysis using length, conservation and Gibbs free energies parameters (see Materials and Methods) defines numerous direct and inverted repeats that together form a complex, multi-tiered, regular structure (Figure 4A). Distinct repeat units of length 36–693 bp (denoted a–f) occur 2–31 times as complete or partial instances (Figure 4B, Supplementary Table 1) and account for the majority of direct, inverted, palindromic and tandem repeats within the region (Figure 5). Units a–e recur in the same relative order within each of

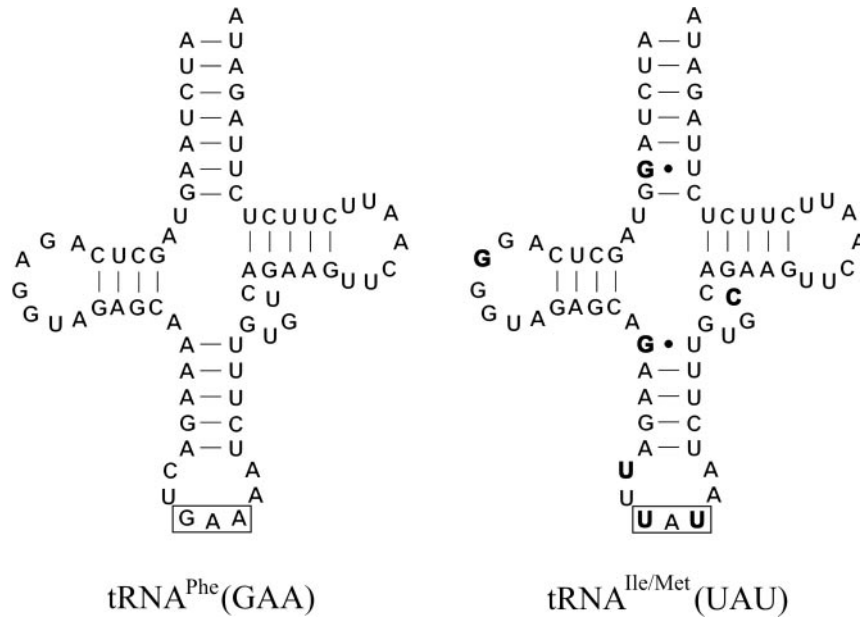

**Figure 3.** High sequence similarity of tRNA<sup>Phe</sup>(GAA) and tRNA<sup>Ile/Met</sup>(UAU) differ by only 7 nt (indicated in boldface), suggesting a recent gene duplication. Both structures are consistent with features of canonical tRNAs that are under evolutionary selection.

five large sections (denoted **1**, **2**, **3**, and **1'**, **2'**; the prime mark indicates reverse complementation; Figure 4C). A large inverted repeat encompasses ~3 kb spanning sections **1** + **2** and **1'** + **2'**. In fact, the only unique sequence in the entire repeat region is a 112 bp sequence (denoted **u**) located at the inversion point.

Tandem repeats are the major repeat arrangement within this large intergenic region (aside from the large inverted repeat previously mentioned). Three regions consist of consecutive copies of unit **b** or **d** (Figure 4C). Unit **b** forms regions with 5.3 and 6.3 consecutive copies in sections **1** and **1'**. Twenty-eight tandem copies of unit **d** make up a region in section **3**, one having an imperfect superstructure composed of two types of unit **d**; type **I** is 36 bp long, while type **II** extends the same pattern 14 bp further (Supplementary Table 1). In addition, sections exhibit a tandem superstructure with each of sections 1–3 and **1'**–**2'** acting as ‘copies’ in a higher-order tandem repeat.

Several types of palindromic sequences (in addition to the large inverted repeat mentioned above) occur in this long intergenic region of *Rhodomonas* mtDNA (Figure 4D). The first type (denoted **z**) has a very low G+C content (25.4%), consists of two inverted copies of unit **d** and recurs as divergent instances in three different sections at the position where **d** abuts unit **c** (**z3**, **z2** and **z2'** in Figure 4A and D). The other three types of palindromes (denoted **w**–**y**) have an unusually high G+C content (53–88%), are perfectly conserved and occur in unit **e** proximal to the inversion point (**u**, see above; **w1'**, **x1'** and **y1'** in Figure 4A and D). Free energy calculations (18,19) indicate that these four palindromic types have the propensity to form stable stem-loop structures *in vivo* (for details see Figure 4D). Notably, four hairpins (**z2**, **z2'**, **w1** and **w1'**) have a tertiary-stabilized GTAA (GNRA) tetraloop albeit without a G–C closing base pair (44,45).

Alignment and comparison of recurring sequences within the repetitive region of *R. salina* mtDNA indicates an extraordinarily high degree of sequence similarity (Supplementary Table 2). Further details regarding substitution, insertion and deletion rates are provided in the Supplementary Material.

### Replication and transcription

Genes are encoded on both DNA strands and their orientation suggests the presence of two transcription units (~12 and 22 kb in length), starting from the repeat region in both directions. Both tandem repeats and stem-loop structures described above might play a role in transcription and/or replication, as suggested for vertebrate animal mtDNAs (46–50). Similarly, in the mtDNA of the red alga *Chondrus crispus*, transcription has been shown to initiate at a bidirectional promoter that is close to a palindromic repeat (51), a feature also present in the red alga *Porphyra purpurea* (5).

We searched *in silico* for potential promoters at three positions in *R. salina* mtDNA (see Materials and Methods): upstream of both inferred primary transcription units (within the repeat region) and upstream of the rRNA gene cluster (*rns*, *rnl*), a postulated secondary transcription unit to assure high expression levels of rRNAs (arrows in Figure 1). Intriguingly, we found a potential 13 nt promoter sequence TAAAAAATATGGT that is located exclusively upstream of *rns* and in the repeat region upstream of both inferred transcription units (within unit **d** and the **z** palindromes of the repeat region), but nowhere else in the genome. The proposed promoter for the transcript to the ‘left’ of the repeat region occurs in each copy of the **d** tandem repeat in section **3**. The one to the ‘right’ occurs within the leftmost copy of unit **d** in section **2'**. Relaxing the promoter motif to the decamer TAAAAAATAT allows inclusion of all unit **d** copies throughout the repeat region, including shadow copies in unit **e** near the **u** inversion

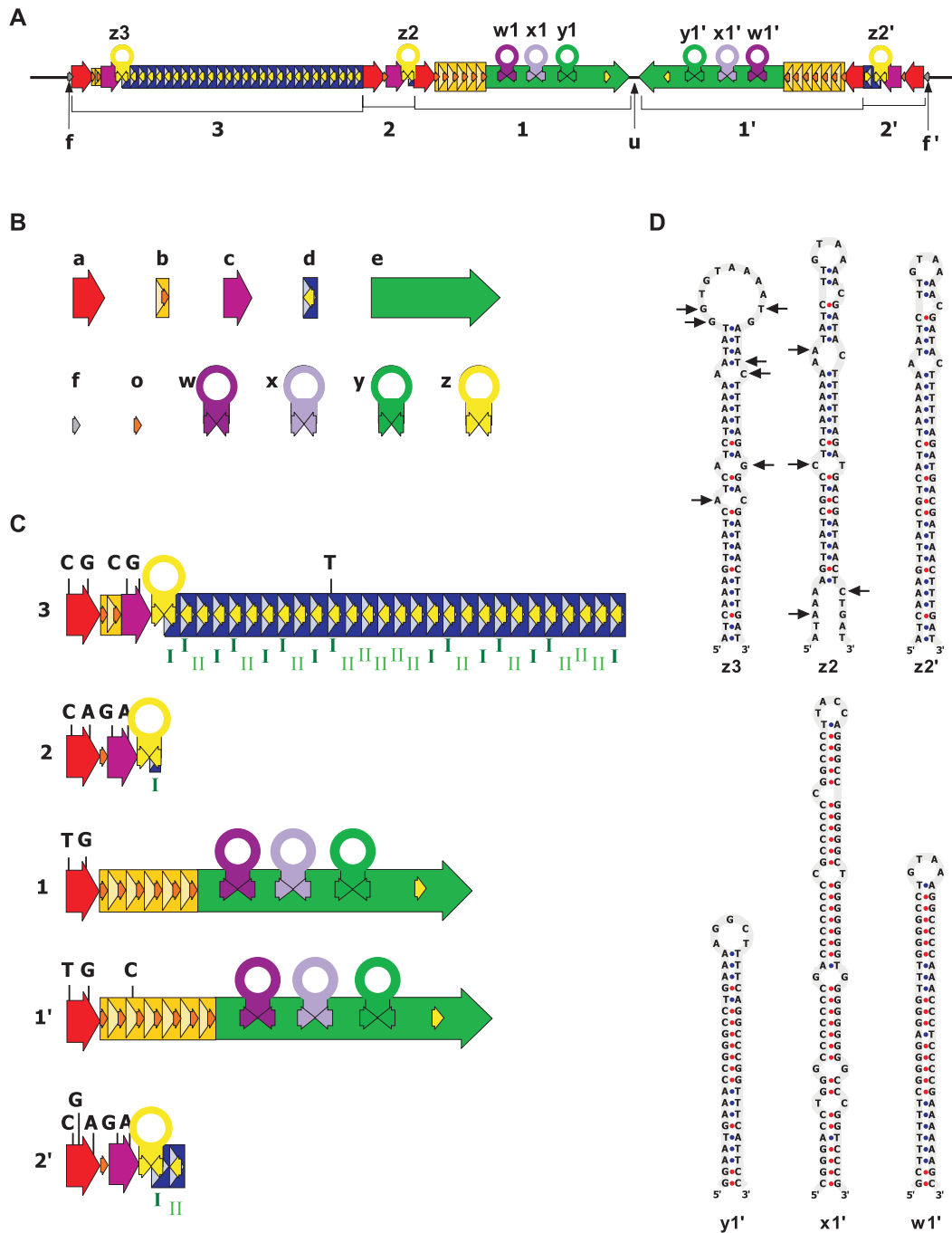

**Figure 4.** Repeat and hairpin structures in the 4.7 kb long intergenic region of the *R.salina* mtDNA. (A) The repeat region spans positions 20 210–24 672. Five recurring repeat units (a–e, shown as colored arrows/triangles) form five sections (1, 2, 3, 1' and 2') bounded by a small repeat unit (f). The arrows/triangles indicate the relative order of repeat units and their orientation. A major inversion switches the orientation of the last two, relative to the first three sections leaving a small 112 bp unique sequence (u) at the inversion point. Nine potential stem-loop structures (w–z) appear as a hairpin symbol and represent two consecutive, inverted occurrences of the same arrow, a palindrome. Consecutive, direct occurrences of the same repeat unit indicate a tandem repeat. (B) A unique letter and unique arrow/triangle represents each recurring unit in the repetitive region. Five major repeat units (a–e) compose the main recurring structure bounded by a sixth repeat unit (f). Other units include a partial representation of b (o) and four palindromic units (w–z). z is a palindrome of two inverted, approximate copies of d. Consensus sequences for each recurring unit are shown in Supplementary Table 2. (C) Magnified representation of all five sections with final two inverted to highlight similar structure. Within sections, repeat units recur in the same relative order albeit as complete, partial, palindromic or tandem occurrences. The tandem repeat in section 3 contains 28 copies of d and the ones in section 1 and 1' has 5.3 and 6.3 copies of b, respectively. Below each d occurrence, specific types (I and II) appear. Nucleotides that differ from the majority are shown above each section with the exception of the z palindromes [for sequence and potential secondary structure of palindromes, see (D)]. Nucleotides at two positions in each of unit a and unit c are shown in all a and c occurrences as they are central to the evolutionary history of the repetitive region. (D) Several palindromic sequences that exhibit a strong potential to form hairpin secondary structures are shown. Three divergent z palindromes are shown ( $\Delta G_{37}$  of  $-14.1$ ,  $-15.5$  and  $-24.5$  kcal/mol for z3, z2 and z2', respectively): arrows indicate nucleotide divergence from z2'. Palindromes w–y recur with complete identity in each unit e ( $\Delta G_{37}$  of  $-26.6$ ,  $-50.8$  and  $-38.2$  kcal/mol, respectively).

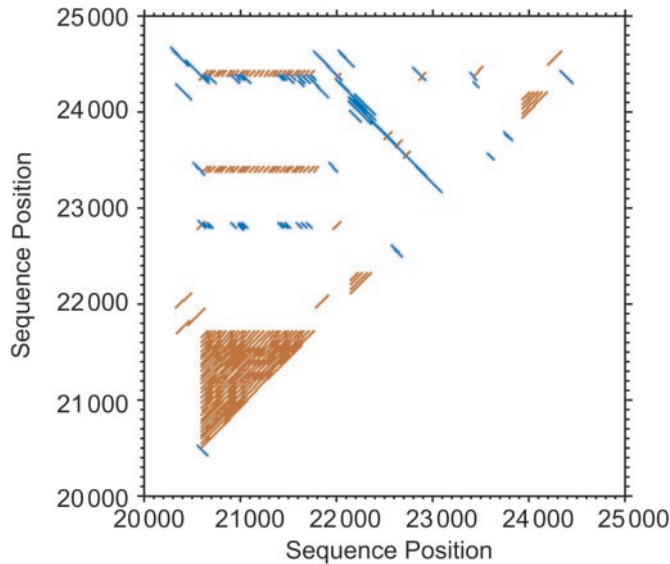

**Figure 5.** Triangular dot-plot of repeat region. Major homologous sequences within the repetitive region are shown using a sequence self-comparison plot that indicates direct (red lines) and inverted (blue lines) repeats. In the image, the three triangles formed by a collection of red lines represent the three tandem repeats and the long blue line indicates the large inversion. A comparison of all windows on both strands using a window of length 50 and allowing at most 20 nt to mismatch ( $w = 50$ ,  $m = 20$ ) produced this plot. Smaller homologies that occur in the repetitive region are not indicated as they require comparison of smaller windows.

point although the decamer also occurs once within a *cox1* intron albeit in the 'wrong' orientation. Notably, the **z** palindromes in section **3** and **2'** contain a copy of either the 10 or 13 nt promoter motif within the stem of the predicted hairpin (**z3** and **z2'** in Figure 4D).

In some mitochondrial systems, origins of replication have been associated with both transcription initiation and repeat regions. Therefore, we asked the question whether the large intergenic region in *Rhodomonas* mtDNA might coincide with the replication start site of this genome. One approach to predict replication origin and terminus is to measure the asymmetric strand distribution of G and C. We determined this distribution using cumulative GC skew [(17), <http://bioinformatics.upmc.edu/GCSkew.html>] that can indicate both a putative replication origin (local minimum) and terminus (local maximum). Indeed, in *Rhodomonas* mtDNA, a local minimum is proximal to the large, intergenic, repeat-containing region and a local maximum occurs where the two opposing directions of transcription meet, thus corroborating the predicted location of the terminus of replication (Figure 6). The precise origin and terminus remain to be mapped by biochemical methods, particularly whether the replication origin is to the 'left', to the 'right' or within the repeat region.

## DISCUSSION

### Primitive features of the *Rhodomonas* mitochondrial genome

With 40 protein genes, the mtDNA of *R.salina* is more gene-rich than that of animals, fungi and plants. Notably,

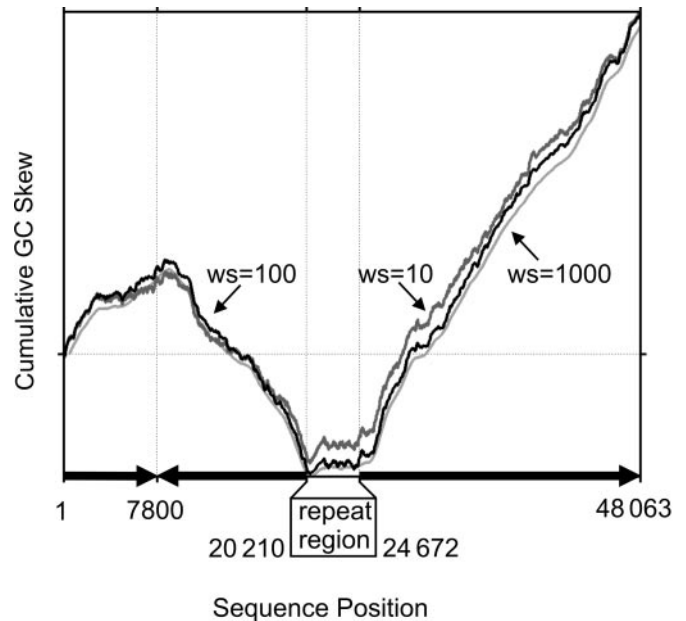

**Figure 6.** Cumulative GC Skew of *R.salina* mtDNA. This plot indicates the Cumulative GC Skew across the circular-mapping genome sequence using three different sliding windows of size 10, 100 and 1000. All three indicate the same probable origin (local minimum at about position 20 000) and terminus (local maximum at  $\sim 7800$ ) of replication. The large arrows along the horizontal axis indicate direction of transcription. Notice that the local minimum occurs at the edge of the repetitive region near probable initiation of transcription and that the local maximum occurs near probable termination of transcription, i.e. where the direction of transcription converges.

mitochondrion-encoded *rps1* and *tatA* are otherwise found exclusively in jakobids and/or malawimonads, believed to be the most primitive mitochondriate eukaryotes known. Other ancestral features of *R.salina* mtDNA include bacteria-like tRNA and rRNA structures and ribosomal protein gene clusters that resemble bacterial operons. Molecular phylogenies based on mitochondrion-encoded protein sequences place *Rhodomonas* basally in the eukaryotic tree, but without significant support (results not shown). More sequence data and broader taxon sampling will be required to substantiate the view that cryptophytes are an early diverging clade.

### Structure and extent of repeat regions in mitochondrial genomes

The *R.salina* repetitive region has a complex, regular structure containing numerous well conserved direct and inverted repeats (Figure 4A–C). Most conspicuous is a large, near perfect, 3 kb palindrome that contains several smaller, yet strong hairpins (Figure 4D). For mtDNA, this region is extremely unusual as it not only is large in size but also has a complex repetitive structure and a high conservation of both sequence and secondary structure.

Densely packed genes and a single, long, repeat-containing intergenic region is also found in mtDNA of a few other taxa. The repeat region of the green alga *Pedinomonas minor* (52) is very different from the one in *Rhodomonas*. It is twice as large (9 kb) and is made up of about twice as many (i.e. 13) distinct families of repeat motifs, with an even broader size range (6–389 bp). Greater sequence variation (up to 25%) occurs

among the copies of a given repeat family, and portions form a highly irregular structure of first-, second- and third-order patterns.

The single intergenic region in animals contains control signals for transcription and replication ('control region') and is typically 1 kb long [e.g. in humans (53)] but expands to as large as 10 kb [e.g. weevils (54)] due to variable number tandem repeats [reviewed in (49)]. Within a species, these repeats contain well conserved motif copies, but have variable copy numbers both within a population and between generations: an indication of ongoing expansion/contraction of this region. Closely related species often have a repeat region in the same location but with diverging sequence pattern and a pattern size quite similar in some clades [e.g.  $151 \pm 27$  bp in lagomorphs (rabbits and hares) (55)] or widely varying in others [e.g. 9–287 bp in *Crocodylidae* (56)].

Finally, a distinct type of long, non-coding repeat regions is the inverted telomeric repeats present at both ends of many linear mitochondrial chromosomes. For example, telomeres of  $\sim 200$  bp to  $\sim 11$  kb long in the ciliate *Tetrahymena* consist of a tandemly arranged short motif [8–40 copies of a 31 bp in *Tetrahymena pyriformis* (57),  $\sim 190$  copies of an  $\sim 52$  bp in *Tetrahymena malaccensis* (58)]. In addition, those in the yeast *Candida parapsilosis* are composed of a much longer recurring motif [e.g. 738 bp (59)].

Formation, expansion and contraction of massive tandem repeats probably take place by slipped mispairing during replication, while repeat inversions seem to involve strand-switching. Experimental evidence for the underlying molecular mechanism is discussed in more detail in the Supplementary Material.

Here, we focused on massed repeat regions in mtDNA. It should be noted that numerous instances of dispersed repeats including recombinationally active repeats and gene duplications have been reported in mtDNAs of plants, fungi, chlorophyte algae, as well as others that are not addressed in the context of this study.

### Evolutionary history of repeat regions in *Rhodomonas* mtDNA

The regular structure of the five sections in the repetitive region of *Rhodomonas* mtDNA suggests two expansion events starting from a hypothetical, ancestral sequence (Figure 7): duplication/inversion (e.g. strand-switching) to create **1 + 2** and **2' + 1'**, and tandem duplication (e.g. by slipped strand mispairing) to create sections **2**, **2'** and **3** (for similarity see Figure 4C and Supplementary Table 1). The order of the two events is unclear with competing arguments supporting alternative histories. The most parsimonious is a two-step history that first duplicates and inverts the seed sequence to form sections **1'** and **2'**, and then duplicates in tandem section **2** to yield **2** and **3** (Figure 7, i–ii). This scenario requires that selective pressure, e.g. a functional constraint, maintains the high degree of similarity within the inversion. Alternatively, a three-step history first duplicates in tandem section **2** to yield **2** and **3**, then duplicates and inverts the entire repeat region to add sections **1'**, **2'** and **3'** and last excises section **3'** (Figure 7, I–III). In this scenario, the excision (e.g. a deletion caused by slipped strand mispairing) acts as a correction event. Although more steps are necessary, this latter history implies that the

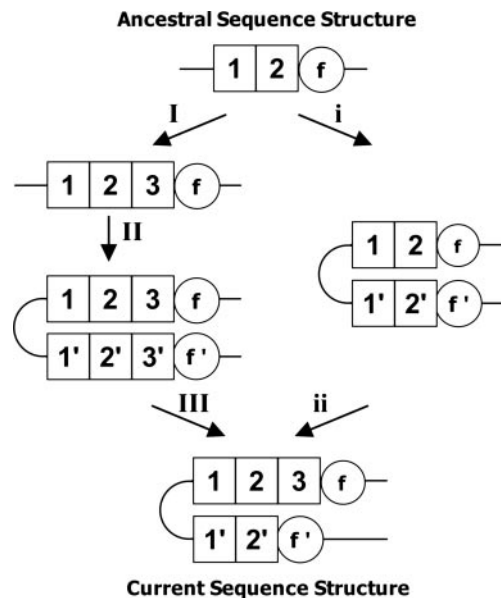

**Figure 7.** Repeat region evolutionary history. Reconstruction of ancestral structure of the repeat region suggests two possible evolutionary histories from one ancestral sequence structure. For simplicity, the structure indicates only sections as denoted in Figure 2. A possible two-step history involves a duplication/inversion of the entire structure (i) followed by duplication of section 2 (ii). A potential three-step history suggests duplication of section 2 (I) followed by a duplication/inversion of the entire structure (II) and excision of section 3' (III).

high sequence similarity between **1 + 2** and **1' + 2'** is not due to selective pressure, but rather to a recent duplication/inversion event.

Intriguingly, a tandem repeat region is present in a similar position in the mtDNA *Guillardia theta*, a cryptophyte that is distantly related to *Rhodomonas* (S. Douglas, T. Cavalier-Smith and U. Maier, unpublished data). This corroborates the notion that the *Rhodomonas* repeat region is ancient, thus pointing to a biological role of this large intergenic genome portion.

### Biological role of the *Rhodomonas* repeat region

In animal mtDNAs, control region tandem repeats contain H-strand and L-strand transcription promoters in each copy of the repeats (55,60). The repeats found in lagomorph mtDNAs contain not only promoters but also a 20 bp sequence conserved across the group, which could represent an element involved in replication initiation (55). Similarly, terminal inverted repeats of linear mitochondrial chromosomes have been implicated in replication initiation (61,62) and in circularization of linear molecules prior to replication (63).

Therefore, we propose that the repeat region in *Rhodomonas* mtDNA is involved in the control of transcription and replication initiation, with several findings supporting this view. First, asymmetric strand distribution of G and C indicates proximity of the intergenic repeat-containing region to a replication origin (Figure 6). As shown in animal mtDNAs, control region repeats occur proximal to the replication origin and may even bind regulatory proteins (55).

Second, two of the three predicted promoters (those upstream of the primary transcription units) fall within the



repeat region. The third promoter lies upstream of the rRNA cluster in order to produce the high expression levels necessary for these rRNAs. The putative promoter motif occurs exclusively in these three locations and is included in a 28-copy tandem repeat. In several mitochondrial genomes, promoters have been predicted to reside in tandem repeats (49,50).

Third, promoters have been demonstrated experimentally to be associated with hairpin structures (46–48,51). Several potentially stable secondary structures are evident within the repeat region, but not elsewhere in *Rhodomonas* mtDNA (Figure 4D). The z palindromes have the potential to form a hairpin structure with a putative transcription promoter in the stem.

## OUTLOOK

The repeat region of the *R.salina* mtDNA occupies a total of 10% of the genome: an expensive addition to an otherwise highly compact genome. If selective pressure minimized non-coding sequence in 90% of the genome, the massive repeat region is unlikely to be parasitic but rather, plays an important biological role. Comparative analysis of further cryptophyte mitochondrial genomes will be instrumental in testing the predictions presented here, inferred from *Rhodomonas* mtDNA. Ultimate testing of these predictions involves biochemical characterization of mitochondrial replication and transcription initiation. Such experiments will require optimization of culture conditions and sub-cellular separation methods in *Rhodomonas*, work ongoing in our laboratories.

## SUPPLEMENTARY MATERIAL

Supplementary Material is available at NAR Online.

## ACKNOWLEDGEMENTS

The authors would like to thank Isabelle Plante for excellent technical assistance. This work was supported by the Canadian Institutes of Health Research (CIHR; SP-34 and MOP-15331) and the Deutsche Forschungsgemeinschaft, Germany. We acknowledge salary and interaction support from the Canadian Institute for Advanced Research (CIAR; B.F.L. and G.B.) and a strategic training fellowship in bioinformatics from the CIHR-Genetics Institute (A.H.). Laboratory equipment and informatics infrastructure was financed in part by Genome Quebec/Canada. Funding to pay the Open Access publication charges for this article was provided by the CIHR.

*Conflict of interest statement.* None declared.

## REFERENCES

- Lang,B.F., Gray,M.W. and Burger,G. (1999) Mitochondrial genome evolution and the origin of eukaryotes. *Annu. Rev. Genet.*, **33**, 351–397.
- Suplick,K., Akella,R., Saul,A. and Vaidya,A.B. (1988) Molecular cloning and partial sequence of a 5.8 kilobase pair repetitive DNA from *Plasmodium falciparum*. *Mol. Biochem. Parasitol.*, **30**, 289–290.
- Lang,B.F., Burger,G., O’Kelly,C.J., Cedergren,R., Golding,G.B., Lemieux,C., Sankoff,D., Turmel,M. and Gray,M.W. (1997) An ancestral mitochondrial DNA resembling a eubacterial genome in miniature. *Nature*, **387**, 493–497.
- Borst,P. and Grivell,L.A. (1981) Small is beautiful—portrait of a mitochondrial genome. *Nature*, **290**, 443–444.
- Burger,G., Saint-Louis,D., Gray,M.W. and Lang,B.F. (1999) Complete sequence of the mitochondrial DNA of the red alga *Porphyra purpurea*. Cyanobacterial introns and shared ancestry of red and green algae. *Plant Cell*, **11**, 1675–1694.
- Pritchard,A.E., Seilhamer,J.J., Mahalingam,R., Sable,C.L., Venuti,S.E. and Cummings,D.J. (1990) Nucleotide sequence of the mitochondrial genome of *Paramecium*. *Nucleic Acids Res.*, **18**, 173–180.
- Burger,G., Zhu,Y., Littlejohn,T.G., Greenwood,S.J., Schnare,M.N., Lang,B.F. and Gray,M.W. (2000) Complete sequence of the mitochondrial genome of *Tetrahymena pyriformis* and comparison with *Paramecium aurelia* mitochondrial DNA. *J. Mol. Biol.*, **297**, 365–380.
- Paquin,B., Laforest,M.J., Forget,L., Roewer,I., Wang,Z., Longcore,J. and Lang,B.F. (1997) The fungal mitochondrial genome project: evolution of fungal mitochondrial genomes and their gene expression. *Curr. Genet.*, **31**, 380–395.
- Burger,G., O’Kelly,C., Gray,M.W. and Lang,B.F. (1999) *Cafeteria roenbergensis* mitochondrial DNA complete sequence OGMP accession no. AF193903.
- Burger,G., Forget,L., Zhu,Y., Gray,M.W. and Lang,B.F. (2003) Unique mitochondrial genome architecture in unicellular relatives of animals. *Proc. Natl Acad. Sci. USA*, **100**, 892–897.
- Douglas,S., Zauner,S., Fraunholz,M., Beaton,M., Penny,S., Deng,L.T., Wu,X., Reith,M., Cavalier-Smith,T. and Maier,U.G. (2001) The highly reduced genome of an enslaved algal nucleus. *Nature*, **410**, 1091–1096.
- Maier,U.G., Douglas,S.E. and Cavalier-Smith,T. (2000) The nucleomorph genomes of cryptophytes and chlorarachniophytes. *Protist*, **151**, 103–109.
- Cavalier-Smith,T., Allsopp,M.T. and Chao,E.E. (1994) Chimeric conundra: are nucleomorphs and chromists monophyletic or polyphyletic? *Proc. Natl Acad. Sci. USA*, **91**, 11368–11372.
- Dacks,J.B., Marinets,A., Ford Doolittle,W., Cavalier-Smith,T. and Logsdon,J.M.,Jr (2002) Analyses of RNA Polymerase II genes from free-living protists: phylogeny, long branch attraction, and the eukaryotic big bang. *Mol. Biol. Evol.*, **19**, 830–840.
- Hansmann,P. and Eschbach,S. (1990) Isolation and preliminary characterization of the nucleus and the nucleomorph of a cryptomonad, *Pyrenomonas salina*. *Eur. J. Cell Biol.*, **52**, 373–378.
- Bullerwell,C.E., Forget,L. and Lang,B.F. (2003) Evolution of monoblepharidalean fungi based on complete mitochondrial genome sequences. *Nucleic Acids Res.*, **31**, 1614–1623.
- Grigoriev,A. (1998) Analyzing genomes with cumulative skew diagrams. *Nucleic Acids Res.*, **26**, 2286–2290.
- SantaLucia,J.,Jr and Hicks,D. (2004) The thermodynamics of DNA structural motifs. *Annu. Rev. Biophys. Biomol. Struct.*, **33**, 415–440.
- Zuker,M. (2003) Mfold web server for nucleic acid folding and hybridization prediction. *Nucleic Acids Res.*, **31**, 3406–3415.
- Bendich,A.J. (1993) Reaching for the ring: the study of mitochondrial genome structure. *Curr Genet.*, **24**, 279–290.
- Bendich,A.J. (1996) Structural analysis of mitochondrial DNA molecules from fungi and plants using moving pictures and pulsed-field gel electrophoresis. *J. Mol. Biol.*, **255**, 564–588.
- Oldenburg,D.J. and Bendich,A.J. (1998) The structure of mitochondrial DNA from the liverwort, *Marchantia polymorpha*. *J. Mol. Biol.*, **276**, 745–758.
- Jacobs,M.A., Payne,S.R. and Bendich,A.J. (1996) Moving pictures and pulsed-field gel electrophoresis show only linear mitochondrial DNA molecules from yeasts with linear-mapping and circular-mapping mitochondrial genomes. *Curr. Genet.*, **30**, 3–11.
- Bonen,L. (1993) *Trans*-splicing of pre-mRNA in plants, animals, and protists. *FASEB J.*, **7**, 40–46.
- Jacob,Y., Seif,E., Paquet,P.O. and Lang,B.F. (2004) Loss of the mRNA-like region in mitochondrial tmRNAs of jakobids. *RNA*, **10**, 605–614.
- Gray,M.W., Lang,B.F., Cedergren,R., Golding,G.B., Lemieux,C., Sankoff,D., Turmel,M., Brossard,N., Delage,E., Littlejohn,T.G. *et al.* (1998) Genome structure and gene content in protist mitochondrial DNAs. *Nucleic Acids Res.*, **26**, 865–878.
- Gray,M.W., Lang,B.F. and Burger,G. (2004) Mitochondria of protists. *Annu. Rev. Genet.*, **38**, 477–524.
- Oda,K., Yamato,K., Ohta,E., Nakamura,Y., Takemura,M., Nozato,N., Akashi,K., Kanegae,T., Ogura,Y., Kohchi,T. *et al.* (1992) Gene

- organization deduced from the complete sequence of liverwort *Marchantia polymorpha* mitochondrial DNA. A primitive form of plant mitochondrial genome. *J. Mol. Biol.*, **223**, 1–7.
29. Turmel, M., Otis, C. and Lemieux, C. (2002) The chloroplast and mitochondrial genome sequences of the charophyte *Chaetosphaeridium globosum*: insights into the timing of the events that restructured organelle DNAs within the green algal lineage that led to land plants. *Proc. Natl Acad. Sci. USA*, **99**, 11275–11280.
  30. Turmel, M., Otis, C. and Lemieux, C. (2002) The complete mitochondrial DNA sequence of *Mesostigma viride* identifies this green alga as the earliest green plant divergence and predicts a highly compact mitochondrial genome in the ancestor of all green plants. *Mol. Biol. Evol.*, **19**, 24–38.
  31. Turmel, M., Otis, C. and Lemieux, C. (2003) The mitochondrial genome of *Chara vulgaris*: insights into the mitochondrial DNA architecture of the last common ancestor of green algae and land plants. *Plant Cell*, **15**, 1888–1903.
  32. Leblanc, C., Boyen, C., Richard, O., Bonnard, G., Grienerberger, J.M. and Kloareg, B. (1995) Complete sequence of the mitochondrial DNA of the rhodophyte *Chondrus crispus* (Gigartinales). Gene content and genome organization. *J. Mol. Biol.*, **250**, 484–495.
  33. Ohta, N., Sato, N. and Kuroiwa, T. (1998) Structure and organization of the mitochondrial genome of the unicellular red alga *Cyanidioschyzon merolae* deduced from the complete nucleotide sequence. *Nucleic Acids Res.*, **26**, 5190–5198.
  34. Viehmann, S., Richard, O., Boyen, C. and Zetsche, K. (1996) Genes for two subunits of succinate dehydrogenase form a cluster on the mitochondrial genome of *Rhodophyta*. *Curr. Genet.*, **29**, 199–201.
  35. Burger, G., Lang, B.F., Reith, M. and Gray, M.W. (1996) Genes encoding the same three subunits of respiratory complex II are present in the mitochondrial DNA of two phylogenetically distant eukaryotes. *Proc. Natl Acad. Sci. USA*, **93**, 2328–2332.
  36. Bullerwell, C.E., Burger, G. and Lang, B.F. (2000) A novel motif for identifying *rps3* homologs in fungal mitochondrial genomes. *Trends Biochem. Sci.*, **25**, 363–365.
  37. O'Brien, E.A., Badidi, E., Barbasiewicz, A., deSousa, C., Lang, B.F. and Burger, G. (2003) GOBASE—a database of mitochondrial and chloroplast information. *Nucleic Acids Res.*, **31**, 176–178.
  38. Tomita, K., Yokobori, S., Oshima, T., Ueda, T. and Watanabe, K. (2002) The cephalopod *Loligo bleekeri* mitochondrial genome: multiplied noncoding regions and transposition of tRNA genes. *J. Mol. Evol.*, **54**, 486–500.
  39. Takai, K. and Yokoyama, S. (2003) Roles of 5-substituents of tRNA wobble uridines in the recognition of purine-ending codons. *Nucleic Acids Res.*, **31**, 6383–6391.
  40. Lavrov, D.V. and Lang, B.F. (2005) Transfer RNA gene recruitment in mitochondrial DNA. *Trends Genet.*, **21**, 129–133.
  41. Michel, F. and Lang, B.F. (1985) Mitochondrial class II introns encode proteins related to the reverse transcriptases of retroviruses. *Nature*, **316**, 641–643.
  42. Lambowitz, A.M. and Zimmerly, S. (2004) Mobile group II introns. *Annu. Rev. Genet.*, **38**, 1–35.
  43. Zimmerly, S., Hausner, G. and Wu, X. (2001) Phylogenetic relationships among group II intron ORFs. *Nucleic Acids Res.*, **29**, 1238–1250.
  44. Antao, V.P., Lai, S.Y. and Tinoco, L., Jr (1991) A thermodynamic study of unusually stable RNA and DNA hairpins. *Nucleic Acids Res.*, **19**, 5901–5905.
  45. Nakano, M., Moody, E.M., Liang, J. and Bevilacqua, P.C. (2002) Selection for thermodynamically stable DNA tetraloops using temperature gradient gel electrophoresis reveals four motifs: d(cGNNAg), d(cGNABg), d(cCNNNg), and d(gCNNGc). *Biochemistry*, **41**, 14281–14292.
  46. Seutin, G., Lang, B.F., Mindell, D.P. and Morais, R. (1994) Evolution of the WANCY region in amniote mitochondrial DNA. *Mol. Biol. Evol.*, **11**, 329–340.
  47. Bogenhagen, D.F. and Clayton, D.A. (2003) The mitochondrial DNA replication bubble has not burst. *Trends Biochem. Sci.*, **28**, 357–360.
  48. Clayton, D.A. (1991) Replication and transcription of vertebrate mitochondrial DNA. *Annu. Rev. Cell Biol.*, **7**, 453–478.
  49. Lunt, D.H., Whipple, L.E. and Hyman, B.C. (1998) Mitochondrial DNA variable number tandem repeats (VNTRs): utility and problems in molecular ecology. *Mol. Ecol.*, **7**, 1441–1455.
  50. Brunk, C.F., Lee, L.C., Tran, A.B. and Li, J. (2003) Complete sequence of the mitochondrial genome of *Tetrahymena thermophila* and comparative methods for identifying highly divergent genes. *Nucleic Acids Res.*, **31**, 1673–1682.
  51. Richard, O., Bonnard, G., Grienerberger, J.M., Kloareg, B. and Boyen, C. (1998) Transcription initiation and RNA processing in the mitochondria of the red alga *Chondrus crispus*: convergence in the evolution of transcription mechanisms in mitochondria. *J. Mol. Biol.*, **283**, 549–557.
  52. Turmel, M., Lemieux, C., Burger, G., Lang, B.F., Otis, C., Plante, I. and Gray, M.W. (1999) The complete mitochondrial DNA sequences of *Nephroselmis olivacea* and *Pedinomonas minor*. Two radically different evolutionary patterns within green algae. *Plant Cell*, **11**, 1717–1730.
  53. Anderson, S., Bankier, A.T., Barrell, B.G., de Bruijn, M.H., Coulson, A.R., Drouin, J., Eperon, I.C., Nierlich, D.P., Roe, B.A., Sanger, F. et al. (1981) Sequence and organization of the human mitochondrial genome. *Nature*, **290**, 457–465.
  54. Boyce, T.M., Zwick, M.E. and Aquadro, C.F. (1989) Mitochondrial DNA in the bark weevils: size, structure and heteroplasmy. *Genetics*, **123**, 825–836.
  55. Casane, D., Dennebouy, N., de Rochambeau, H., Mounolou, J.C. and Monnerot, M. (1997) Nonneutral evolution of tandem repeats in the mitochondrial DNA control region of lagomorphs. *Mol. Biol. Evol.*, **14**, 779–789.
  56. Ray, D.A. and Densmore, L.D. (2003) Repetitive sequences in the crocodilian mitochondrial control region: poly-A sequences and heteroplasmic tandem repeats. *Mol. Biol. Evol.*, **20**, 1006–1013.
  57. Middleton, P.G. and Jones, I.G. (1987) The terminus of *Tetrahymena pyriformis* mtDNA contains a tandemly repeated 31 bp sequence. *Nucleic Acids Res.*, **15**, 855.
  58. Morin, G.B. and Cech, T.R. (1988) Telomeric repeats of *Tetrahymena malaccensis* mitochondrial DNA: a multimodal distribution that fluctuates erratically during growth. *Mol. Cell. Biol.*, **8**, 4450–4458.
  59. Nosek, J., Dinouel, N., Kovac, L. and Fukuhara, H. (1995) Linear mitochondrial DNAs from yeasts: telomeres with large tandem repetitions. *Mol. Gen. Genet.*, **247**, 61–72.
  60. Ritchie, P.A. and Lambert, D.M. (2000) A repeat complex in the mitochondrial control region of Adelie penguins from Antarctica. *Genome*, **43**, 613–618.
  61. Pritchard, A.E., Laping, J.L., Seilhamer, J.J. and Cummings, D.J. (1983) Inter-species sequence diversity in the replication initiation region of *Paramecium* mitochondrial DNA. *J. Mol. Biol.*, **164**, 1–15.
  62. Pritchard, A.E. and Cummings, D.J. (1981) Replication of linear mitochondrial DNA from *Paramecium*: sequence and structure of the initiation-end crosslink. *Proc. Natl Acad. Sci. USA*, **78**, 7341–7345.
  63. Rycovska, A., Valach, M., Tomaska, L., Bolotin-Fukuhara, M. and Nosek, J. (2004) Linear versus circular mitochondrial genomes: intraspecies variability of mitochondrial genome architecture in *Candida parapsilosis*. *Microbiology*, **150**, 1571–1580.