

Hox Gene Collinearity: From A-P Patterning to Radially Symmetric Ani-mals



Spyros Papageorgiou*

Institute of Biosciences and Applications, NCSR 'Demokritos' Athens, Greece

Abstract: Hox gene collinearity relates the gene order of the Hox cluster in the chromosome (telomeric to centromeric end) with the serial activation of these genes in the ontogenetic units along the Anterior-Posterior embryonic axis. Although this collinearity property is well respected in bilaterians (e.g. vertebrates), it is violated in other animals. The A-P axis is established in the early embryo of the *sea urchin*. Subsequently, rotational symmetry is superimposed when the vestibula larva is formed. In analogy to the linear A-P case, it is here hypothesized that the circular topology of the ontogenetic modules is associated to the architectural restructuring of the Hox loci where the two discrete ends of the Hox cluster approach each other so that an almost circular DNA contour is created. In the evolutionary process the circular mode undergoes double strand breaks and the generated cluster ends are attached to the open ends of the flanking chromosome. This event may lead to a novel gene ordering associated with an evolutionary innovation. For example, the loss of Hox4 is followed by the formation of a shorter gene circular arrangement. The opening of this contour at the missing Hox4 location and its connection to the chromosomal flanking ends leads to a new diversification namely the creation of the unusual gene order of the *sea urchin* Hox cluster.

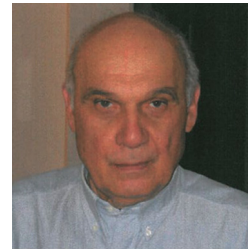

S. Papageorgiou

Keywords: Hox collinearity, Sea urchin, Echinoderm evolution.

Received: January 01, 2016

Revised: April 14, 2016

Accepted: June 10, 2016

1. INTRODUCTION

Almost forty years ago E.B. Lewis made a remarkable observation by applying classical genetic methods on the genes of the bithorax complex (*BX-C*) of the *Drosophila* embryo [1]: he noticed that a set of genes located in sequence along the telomeric to centromeric direction on the third chromosome are activated in ontogenetic modules following the same order along the anterior-posterior axis of the embryo. This is a surprising correlation (coined *spatial gene collinearity*) between gene locations on the chromosome and gene activation in sequential embryonic areas. These genes are called Hox genes and in most cases they form complexes called Hox clusters. It was later astonishingly established that these genes are found in many other animal genomes and collinearity is a widespread property. This spatial collinearity of Hox clusters is observed in many animal clades, humans included. The evolutionary origin of collinearity is intensively studied [2]. Conventionally the Hox genes are sequentially numbered in the 3' to 5' direction starting from the telomeric end, Hox1 Hox2 Hox3,.... In vertebrates transcription proceeds in the 5' to 3' direction for all genes of the Hox cluster. Spatial collinearity is most pronounced in vertebrates where two other forms of collinearity have been

established. The timing of gene activation follows a *temporal collinearity*: Hox1 is activated first, then Hox2 is activated followed by Hox3 and so on [3]. Furthermore, another kind of collinearity was also observed: when at a given location along the anterior-posterior axis of an embryo several Hox genes are activated, the expression of the most posterior gene (5') in the cluster is stronger compared to the expressions of the other more anterior genes (3') (*quantitative collinearity*) [4].

During animal evolution the organization of Hox genes has taken divergent forms. In particular, it was assumed that tandem duplication of an ancestral ur-Hox gene and sequential evolutionary modifications led to the generation of an organized gene array [5, 6]. Durston has proposed that posterior prevalence (the dominance of posterior Hox genes over anterior ones) plays a unique role to vertebrate evolution [7]. Temporal collinearity coordinates the timely Hox gene expression and the posterior vertebrate Hox genes are expressed later than the anterior genes. Therefore the posterior Hox genes need posterior prevalence in order to 'exert their function' against the precedent expression of the anterior Hox genes [7]. From the different forms of these Hox gene clusterings (from tight and ordered to disordered or split), the vertebrate clusters are organized in a short and compact form [2]. Across the animal kingdom there are variable numbers of Hox clusters in different species. For instance, many vertebrates have four paralogous clusters (HoxA, HoxB, HoxC and HoxD) located on different chromosomes.

*Address correspondence to this author at the Institute of Biosciences and Applications, NCSR 'Demokritos' Athens, Greece;
Tel: +30-210-8954920; E-mail: spapage@bio.demokritos.gr

Spatial collinearity is a multiscale interrelation and it applies to development along the A-P embryonic axis. In the present work this interrelation is extended to rotationally symmetric organisms. In the sea urchin, a typically rotationally symmetric animal, the gene order in the Hox cluster differs from the usual vertebrate gene order. The hypothesis is put forward that this unusual gene order is interrelated to the rotationally symmetric structure of the sea urchin.

2. HOX GENE ACTIVATION ALONG THE ANTERIOR-POSTERIOR AXIS

Understanding the mechanisms responsible for the surprising collinearity features is a challenging problem. To this end, during the last fifteen years a series of genetic engineering experiments were performed on the primary A-P axis or the limb axis of developing mice. Hox genes were either deleted or duplicated in mouse genomes and the consequences on the mutant developing embryos were studied [8-11]. In particular, the expression of the Hox genes located either posteriorly or anteriorly to the deleted (or duplicated) gene(s) were analyzed. The deviations from the wild type expressions are characteristic and indicative of how the Hox gene activation proceeds.

The above experiments are helpful to understand the underlying mechanism of Hox gene collinearity. Several models were proposed in order to reproduce the data of Hox gene expressions [9-11]. These models are based mainly on biomolecular mechanisms as established from the well studied genetic and biochemical processes. Such a characteristic biomolecular model is the *two-phases* model proposed for the HoxD cluster expressions in the developing primary anterior-posterior axis of the vertebrates [10]. According to this model in an early phase two influences act on the HoxD cluster. One is positive and originates from the telomeric side (3') of the cluster as already determined from the limb bud analysis [9]. This activation is balanced by a repressive influence coming from the centromeric side of the cluster. The two influences combine and produce a sequential chromatin opening that leads to a pattern of partially overlapping expressions in the anterior-posterior direction. The above biomolecular models can account for many (but not all) of the genetic engineering results while several other data are unexpected [9, 10].

A different approach is followed in a model, the *biophysical model*, which is based on the application of physical principles. According to this model when the Hox genes are inactive the entire Hox cluster is confined inside the chromatin territory (CT). When the cluster is activated, physical forces are generated and the genes are pulled one after the other toward the interchromosome domain (ICD) and particularly toward the area of the transcription factory (TF) where transcription is possible. This model was first proposed in 2001 [12] and, until recently, it is successfully applied and compared to the compiled experimental data [13-16]. The case of electrostatic attraction was elaborated in detail [13].

3. ONTOGENY OF ECHINODERMS

The above models aim at explaining Hox gene activation along the Anterior-Posterior axis of the developing verte-

brates with a particular application to the mouse embryo. Vertebrate embryogenesis is a characteristic example of direct development according to which the main features of the adult body plan are laid down immediately during embryogenesis [17]. Besides this direct mode of development, a wide range of animal species follows indirect developmental path: the early embryo is transformed into a free-living larva whose appearance is different from the adult body plan of the species. The larva is capable of feeding and growth and in maximal indirect development, the adult body plan is formed within the larva but it has no similarity to the larva itself [17]. *Strongylocentrotus purpuratus* is a typical indirectly developing sea urchin (Fig. 1).

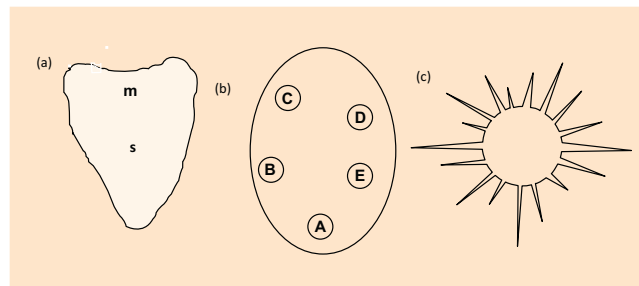

Fig. (1). Developmental stages of echinoderms. **a)** *Strongylocentrotus purpuratus* embryo where **m** and **s** stand for the mouth and stomach along the A-P axis respectively [17]. **b)** *Holopneustes purpurascens* vestibula larva with A, B, C, D and E podia locations [21]. **c)** Juvenile sea urchin [17].

The *S. purpuratus* genome sequencing was first released in 2006 by an international Consortium set up for this purpose [18]. Thereafter, the genetic study of echinoderms and, particularly the sea urchin Hox gene cluster, is advancing rapidly [19]. A striking first result from this DNA analysis is the unusual gene order in the sea urchin Hox cluster as compared to the vertebrate Hox cluster [19]. The gene locations in these characteristic clusters are depicted in (Fig. 2). The Hox gene arrangement of (Fig. 2) is only indicative of the gene ordering and it does not represent the real distances between the genes.

Note that the normal (vertebrate) orientation of gene activation is not preserved in the sea urchin Hox cluster [19]. According to an analysis of the Hox loci of different species, the vertebrates possess the more compact and well organized Hox clusters [2]. In contrast, the Hox clusters of echinoderms are spreading in a wider area along their chromosomes and their structure, compared to the vertebrates, is disorganized [2]. Among the different indirectly developing organisms only the echinoderms are examined here for which the gene order in their Hox gene clusters is surely determined.

In echinoderms, bilateral symmetry and anterior-posterior patterning clearly appear at the very early stages of their ontogeny before the larva stages [20, 21]. The A-P axis runs from the mouth (the anterior end) through the adult coelomic compartments [21] (Fig. 1a). Subsequently and for the sea urchin adult rudiment, radial symmetry is also detected [21, 22]. The echinoderm pentaradiality results from the superposition of radial symmetry on bilateral symmetry [21, 22]. In (Fig. 1) a drawing is depicted of the sea urchin developmental stages from embryo to juvenile.

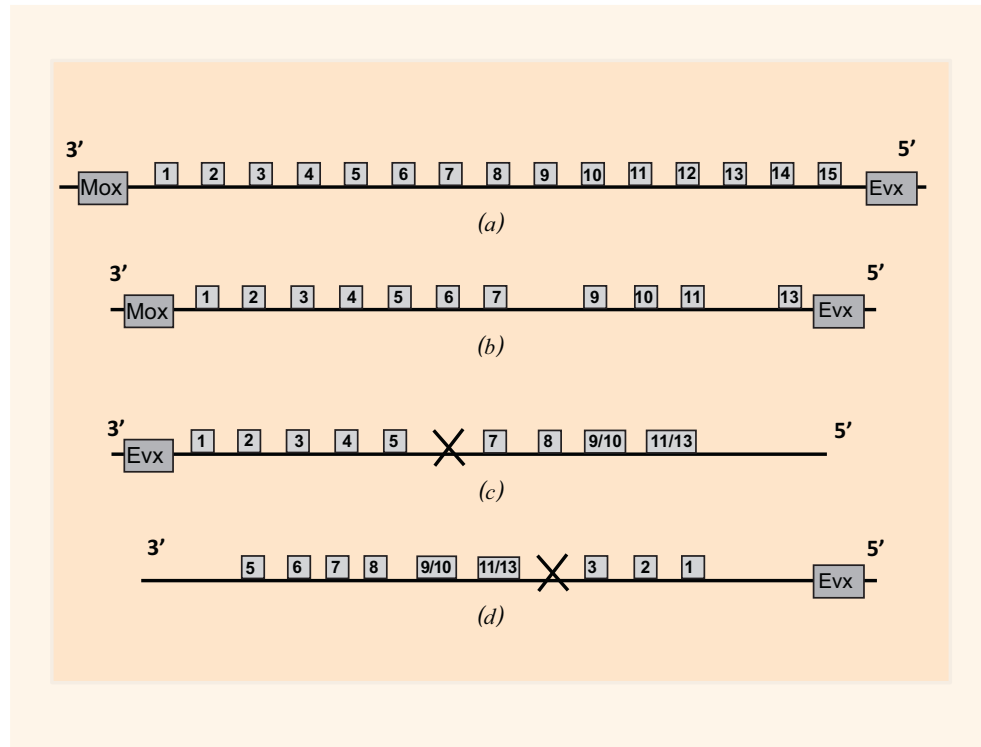

Fig. (2). Gene ordering in Hox gene clusters. **a)** Theoretical Hox gene order of the common ancestor. Mox and Evx genes are located in the side of the anterior and posterior ends of the Hox cluster respectively [20]. **b)** The HoxA cluster of the mouse (vertebrate) [20]. **c)** The Hox cluster of *A. planci*. Hox6 is missing [28]. **d)** The Hox cluster of the sea urchin *S. purpuratus*. Hox4 is missing [29].

For the different mathematical forms of Symmetry and particularly the applications to echinoderms see the thought provoking book of H. Weyl [23]. The principal symmetries observed in both animals and plants are resulting from the two fundamental operations of reflections and rotations in space [23]: (a) a body (a geometric configuration) is bilaterally symmetric with respect to a plane P if it is carried into itself when reflected in P. (b) a body is rotationally symmetric around an axis L if it is carried into itself by a rotation around L [23]. The angle of rotation α may be $\alpha = (2\pi/n)$ where $n = 1, 2, 3, \dots$ determines the order of rotation. For example, for $n = 2$ the body is symmetric for a rotation of 180° . The case of the pentamerous body structure of the sea urchin *Holopneustes purpurascens* with the five primary podia located on a circular arrangement around the axis is depicted in (Fig. 1b). An angular rotation $(2\pi/5)$ around the axis translocates the podia: A to B, B to C, C to D, D to E and E back to A. For the purposes of the present work it is not necessary to refer to the important case of three-dimensional bodies with left-right symmetry or asymmetry.

It is tempting to presume that the emerging symmetries of the sea urchin are related to the unusual Hox gene order in the cluster. How this interrelation is achieved remains to be clarified. In the present work an evolutionary pathway is proposed leading from the normal (usual) Hox gene order of a common ancestor to the unusual order of the echinoderm Hox cluster (see section 4).

In order to keep up with a circular description of rotational symmetry it is useful to use a clockface notation of the polar coordinates with the 13 ‘hours’ representing 13 puta-

tive ontogenetic modules arranged on a circumference (Fig. 3a). This presumptive circular arrangement is also used for the Hox gene cluster ordering at some evolutionary stage.

In recent years the architectural restructuring of the Hox loci in embryos has been intensively studied [11, 24]. It has been noticed that reorganization of the cluster occurs at the various developmental stages of Hox activity. The reorganization, without changing the gene order, consists mainly of a size modification of the cluster causing a variation of the relative distance between the Hox genes [25, 26]. In directly developing organisms (in particular the HoxD cluster of mice) a bi-modality is observed consisting of two Topological Associating Domains (TAD) acting on the two ends (telomeric and centromeric) of the HoxD cluster [25, 26]. Very little is known of the origin of these topologies. From extensive studies on the invertebrate amphioxus it is inferred that the bi-partite TAD structure in the vertebrates is an evolutionary novelty derived from a single regulatory system covering the anterior side of the Hox cluster [27].

Hox activity is differentiated during the developmental stages of the sea urchin [17, 28]: the Hox genes of *S. purpuratus* are activated at the larva stages and then intensively transcribed in the juvenile stage.

4. EVOLUTIONARY CONSIDERATIONS

In the directly developing vertebrates the last gene Hox13 at the posterior end (5') of the cluster is neighboring the Even-skipped gene (Evx) while the first gene Hox1 at the anterior end (3') is located on the same side with Mox (Fig. 2a, b) [20, 28, 29]. The location of Evx and Mox in relation

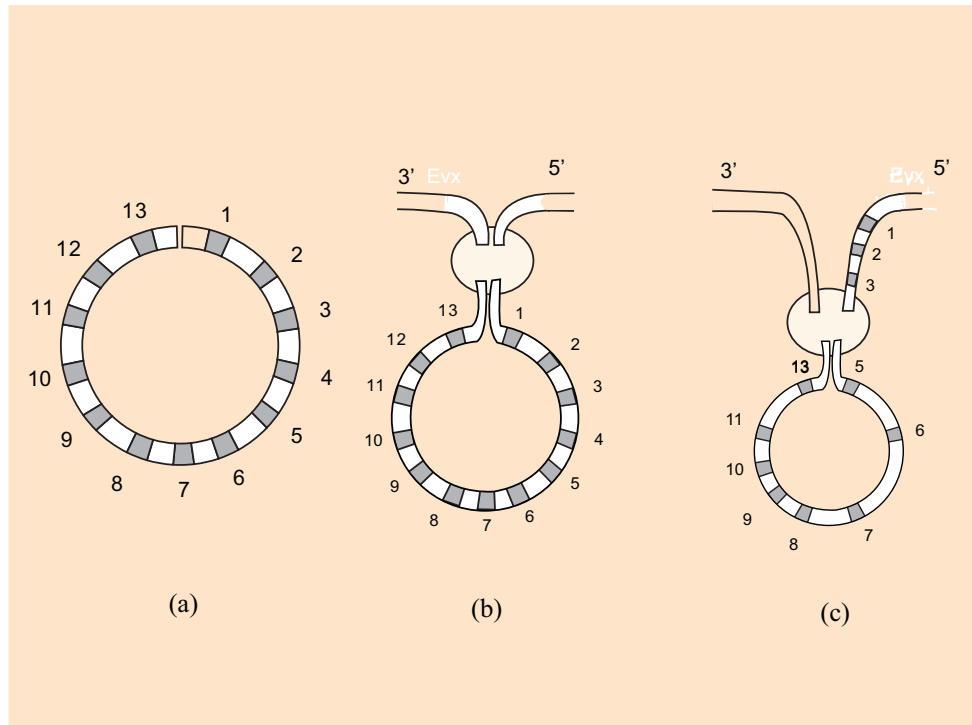

Fig. (3). DNA contours. **a)** The linear DNA fiber is restructured and twisted so that the two ends of the linear Hox cluster come close together. **b)** In the encircled domain the ends of the circularized cluster (Hox1 and Hox13) are connected to the 3' and 5' ends of the flanking chromosome. If Hox1 is attached to the 3' end and Hox13 to the 5' end the linear arrangement produces the *A. planici* gene order (Fig. 2c). **c)** If Hox5 is connected to the 3' end and Hox13 to Hox3 on the flanking chromosome, the linear arrangement represents the sea urchin Hox cluster (Fig. 2d).

with the Hox cluster in the chromosome is not fixed. Their relative position, when determined, is indicated in (Fig. 2) [28, 29].

For the indirectly developing *Acanthaster planici* (*A. planici*), several models were proposed according to which the genes of the ancestral cluster experience an inversion and translocation [28, 29]. The situation was recently settled and it was found that in *A. planici* the Hox gene ordering from 3' to 5' is the same as the normal vertebrate arrangement (Fig. 2b, c) [28, 29]. In the unusual Hox ordering of the sea urchin, Hox1 to Hox3 have been translocated to the 5' end of the cluster while the other genes are inverted and translocated to the 3' end as shown in (Fig. 2d) [28, 29]. *Evx* is located anteriorly to the Hox cluster in *A. planici* whereas in the sea urchin it is located posteriorly (Fig. 2).

Ordinary collinearity is based on a multiscale linear interrelation: on one hand the Hox cluster in the chromosome with discrete ends in the 3' to 5' direction and on the other hand the ontogenetic units along the anterior-posterior axis of the embryo. The two linear orderings are similar to each other and they are formally positioned on a finite straight line. The pattern along the embryonic anterior-posterior axis extends in a macroscopic scale of the order up to 1mm. On the other hand the (microscopic) size of a typical Hox cluster is of the order of 500 nm [13, 26]. The correlation of sequential structures in spatial dimensions differing by more than 3 orders of magnitude renders Hox gene collinearity a characteristically multiscale phenomenon. It is tempting to assume that in the course of evolution an analogous interrelation

should hold for animals with rotational symmetry. In this spirit, the radial (rotational) organization of the ontogenetic units of the sea urchin should be similar at some stage to the gene ordering of the Hox cluster (Fig. 3a). Admittedly this is a daring hypothesis worth pursuing in the quest for direct (or indirect) supporting evidence.

The above similarity is reminiscent (or special case) of self similarity. In Nature a wide class of phenomena and structures are self similar (scale invariant). An object is self similar if the image of a part of this object is similar to the image of the whole. Examples are the image of a coastline, a snowflake or a branching neuron depicted at different magnifications. B. B. Mandelbrot was the first who studied these objects (fractals) in depth for a wide class of cases [30].

The main evolutionary question remains: how do the chordates and echinoderms evolve from a common bilaterally symmetric ancestor 480-520 million years ago [20, 29]. (See the simplified phylogenetic diagram of Fig. 4). In this diagram the common ancestor (left) has the usual Hox cluster ordering which is preserved in the clade of vertebrates (Figs. 2a, b).

It is now assumed that in the case of rotationally symmetric organisms the ancestral arrangement of the Hox cluster is circularized (Fig. 3a) and attached to the flanking chromosome (Fig. 3b). A random double strand break at both ends of the cluster enables the interchangeable reconnection of the cluster to the flanking chromosome (Fig. 3b). The circular configuration of the cluster brings Hox1 in the neighborhood of Hox13 inside the encircled domain of (Fig. 3b, c). This

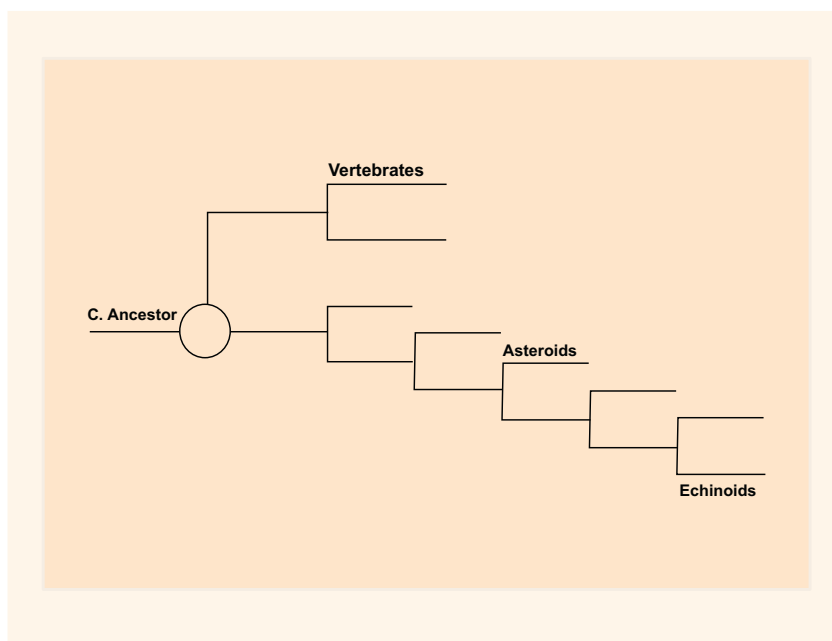

Fig. (4). Simplified phylogenetic diagram for Vertebrates, Asteroids and Echinoids. Diversifications from the Common Ancestor (left) of the gene order in the Hox cluster. The vertebrates (top) retain the usual gene order of the common ancestor. The gene order of the asteroid Hox cluster (middle) is similar to the usual ordering and with a subsequent rearrangement of the gene order, the sea urchin Hox cluster is created (bottom).

vicinity facilitates the (multiple) double strand break at the ends of the cluster. The two ends of the cluster (Hox1 and Hox13) are then attached to the two ends of the flanking chromosome. Two connecting combinations can occur: in the first case, Hox1 and Hox13 are connected to the 3' and 5' chromosome ends respectively. The resulting Hox gene order in the linear deployment is the usual ancestor (and vertebrate) order and it was recently confirmed that the Hox cluster of *A. planici* follows the same ordering (Fig. 2c) [28, 29]. The transposition of *Evx* at the 3' side of the cluster is probably a subsequent event. In contrast, an evolutionary novelty would be produced if the neighboring Hox13 and Hox1 of the contour were interchangeably connected to the 3' and 5' ends of the chromosome.

For the unusual Hox gene order of the sea urchin, the following 2-step procedure is proposed: Step 1: the circularized usual Hox order (Fig. 3a) is recombined so that Hox1 is attached to the 5' end and Hox13 to the 3' end of the flanking chromosome (Fig. 3b). This constitutes a novel combination. Step2: The Hox cluster breaks at the Hox4 location and Hox4 is deleted. The residual DNA segment [Hox5,....., Hox13] is circularized so that a smaller closed contour is formed (Fig. 3c). This contour then opens and its ends (Hox5 and Hox13) are connected to the open ends of the chromosome (Fig. 3c). Following the same reasoning as in the case of *A. planici*, the combinatorial connection of Hox5 and Hox13 to the 3' and 5' ends of the chromosome respectively leads to the unusual gene order of the sea urchin (Fig. 2d). The above hypotheses remain to be tested.

5. PREDICTIONS AND DISCUSSION

In order to test the validity of a model, it is crucial to propose experiments whose outcome could either support or disagree with the model predictions. In recent years powerful

techniques have been developed which can determine with high precision the distances between genes. Such a method, the 3D fluorescence in situ hybridization (FISH), was applied by Duboule and collaborators to estimate the distances between the genes of the vertebrate HoxD cluster [25, 26]. It was found that, when all Hoxd genes are activated, the HoxD cluster is elongated and the distance between the first (Hoxd1) and last (Hoxd13) genes is of the order of 500 nm [25]. This distance is much shorter when the Hox genes are not transcribed and the Hox cluster is condensed inside the CT [25].

If the above methodology could be applied at the different developmental stages of *A. planici*, the findings should be compared to the mouse HoxD results, according to the present model (and the biophysical model [15, 16]). In particular growth zones of echinoderms, the cluster segment [Hox5, Hox7,...Hox11/13] is collinearly expressed [28]. In the zone where Hox 11/13 is expressed the Hox cluster should be elongated and Hox5 should be located at a distance D_5 from Hox11/13. In the early developmental stages when the Hox cluster is not yet activated, the cluster is shorter and condensed inside the CT. Therefore the distance of Hox5 from Hox11/13 should be smaller than D_5 . It would be illuminating if this could be experimentally confirmed.

Spatial and temporal regulation of the Hox gene cluster are intimately related to the gene order within the cluster [31]. Vertebrates have preserved the compactness of the common ancestor. It was proposed that temporal collinearity is the main constraint leading to tight clustering [31]. When temporal collinearity is relaxed, transposable elements invade in the cluster and the organized cluster can become disorganized [31].

The present work is focused on the evolutionary transition from the usual Hox gene order of the common ancestor to the unusual order in the sea urchin. The important issue of Hox gene expression in time and space for the clade of echinoderms has not been treated. The reason is that the existing data (e.g. [17, 28]) are still fragmentary and cannot be reliably used for a detailed description in a comprehensive model form.

LIST OF ABBREVIATIONS

CT	=	Chromatin territory
ICD	=	Interchromosome domain
TF	=	Transcription factory
PCM	=	Polar coordinate model

CONFLICT OF INTEREST

The author(s) confirm that this article content has no conflict of interest.

ACKNOWLEDGEMENTS

I am indebted to Drs Yannis Almirantis for reading the manuscript, Antony Durston for encouraging correspondence and David Ferrier for insightful suggestions.

REFERENCES

- [1] Lewis, E.B. A gene complex controlling segmentation in *Drosophila*. *Nature*, **1978**, *276*, 565-570.
- [2] Duboule, D. Rise and fall of Hox gene clusters. *Development*, **2007**, *134*, 2549-2560.
- [3] Izpisua-Belmonte, J.-C.; Falkenstein, H.; Dollé, P.; Renucci, A.; Duboule, D. Murine genes related to the *Drosophila AbdB* homeotic gene are sequentially expressed during development of the posterior part of the body. *EMBO J.*, **1991**, *10*, 2279-2289.
- [4] Dollé, P.; Izpisua-Belmonte, J.-C.; Brown, J.M.; Tickle, C.; Duboule, D. *HOX-4* genes and the morphogenesis of mammalian genitalia. *Genes & Dev.*, **1991**, *5*, 1767-1777.
- [5] Gehring, W.J.; Kloter, U.; Suga, H. Evolution of the *Hox* gene complex from an evolutionary ground state. *Curr. Top. Dev. Biol.*, **2009**, *88*, 35-61.
- [6] Durston, A.J.; Jansen, H.J.; in der Rieden, P.; Hooiveld, M.H.W. *Hox* collinearity: a new perspective. *Int. J. Dev. Biol.*, **2011**, *55*, 899-908.
- [7] Durston, A.J. Global posterior prevalence is unique to vertebrates: a dance to the music of time? *Dev. Dyn.*, **2012**, *241*, 1799-1807.
- [8] Kmita, M.; Fraudeau, N.; Hérault, Y.; Duboule, D. Serial deletions and duplications suggest a mechanism for the collinearity of *Hoxd* genes in limbs. *Nature*, **2002**, *420*, 145-150.
- [9] Tarchini, B.; Duboule, D. Control of *Hoxd* genes' collinearity during early limb development. *Dev. Cell*, **2006**, *10*, 93-103.
- [10] Tschopp, P.; Tarchini, B.; Spitz, F.; Zakany, J.; Duboule, D. Uncoupling time and space in the collinear regulation of *Hox* genes. *PLoS Genetics*, **2009**, *5*(3).
- [11] Noordermeer, D.; Leleu, M.; Splinter, E.; Rougemont, J.; de Laat, W.; Duboule, D. The dynamic architecture of *Hox* gene clusters. *Science*, **2011**, *334*, 222-225.
- [12] Papageorgiou, S. A physical force may expose *Hox* genes to expression in a morphogenetic density gradient. *Bull. Math. Biol.*, **2001**, *63*, 185-200.
- [13] Papageorgiou, S. Pulling forces acting on *Hox* gene clusters cause expression collinearity. *Int. J. Dev. Biol.*, **2006**, *50*, 301-308.
- [14] Papageorgiou, S. Comparison of models for the Collinearity of *Hox* genes in the developmental axes of Vertebrates. *Curr. Genomics*, **2012**, *13*, 245-251.
- [15] Almirantis, Y.; Provata, A.; Papageorgiou, S. Evolutionary constraints favor a biophysical model explaining *Hox* gene collinearity. *Curr. Genomics*, **2013**, *14*, 279-288.
- [16] Papageorgiou, S. Towards resolving the enigma of *Hox* gene collinearity. In *Chaos, Information processing and paradoxical games. The legacy of John S. Nicolis*. Nicolis G; Basios, V. Eds; World Scientific, Singapore, **2015**, pp. 253-273.
- [17] Arenas-Mena, C.; Martinez, P.; Cameron, R. A.; Davidson, E. H. Expression of the *Hox* gene complex in the indirect development of a sea urchin. *Proc. Nat. Acad. Sci. USA*, **1998**, *95*, 13062-13067.
- [18] Sea Urchin Genome Consortium. The genome of the sea urchin *Strongylocentrotus purpuratus*. *Science*, **2006**, *314*, 941-952.
- [19] Cameron, R.A.; Rowen, L.; Nesbitt, R.; Bloom, S.; Rast, J.P.; Berney, K.; Arenas-Mena, C.; Martinez, P.; Lucas, S.; Richardson, P.M.; Davidson, E.H.; Peterson, K.J.; Hood, L. Unusual gene order and organization of the sea urchin *Hox* cluster. *J. Exp. Zool. B. Mol. Dev. Evol.*, **2006**, *306*, 45-58.
- [20] David, B; Mooi, R. How *Hox* genes can shed light on the place of echinoderms among the deuterostomes. *EvoDevo*, **2014**, *5*, 22-41.
- [21] Morris, V. B. Origins of radial symmetry identified in an echinoderm during adult development and the inferred axes of ancestral bilateral symmetry. *Proc. R. Soc. B.*, **2007**, *274*, 1511-1516.
- [22] Mooi R.; David, B. Radial symmetry, the Anterior-Posterior axis and echinoderm *Hox* Gene. *Ann. Rev. of Ecology, Evolution and Systematics*, **2008**, *39*, 43-62.
- [23] Weyl, H. Symmetry. Princeton University Press, Princeton, USA, **1952**.
- [24] Champeyron, S.; Bickmore, W. Chromatin decondensation and nuclear reorganization of the *HoxB* locus upon induction of transcription. *Genes & Dev.*, **2004**, *18*, 1119-1130.
- [25] Noordermeer, D.; Leleu, M.; Schorderet, P.; Joye, E.; Chabaud, F.; Duboule, D. Temporal dynamics and developmental memory of 3D chromatin architecture at *Hox* gene loci. *eLife*, **2014**, *3*:e02557.
- [26] Fabre, P.J.; Benke, A.; Joye, E.; Nguyen Huynh, T.H.; Manley, S.; Duboule, D. Nanoscale spatial organization of the *HoxD* gene cluster in distinct transcriptional states. *Proc. Nat. Acad. Sci. USA*, **2015**, *112*, 13964-13969.
- [27] Acemel, R.D.; Tena, J.J.; Irastorza-Azcarate, I.; Marlétaz, F.; Gómez-Marín, C.; de la Calle-Mustienes, E.; Bertrand, S.; Diaz, S.G.; Aldea, D.; Aury, J.M.; Mangenot, S.; Holland, P.W.; Devos, D.P.; Maeso, I.; Escrivá, H.; Gómez-Skarmeta, J.L. A single three-dimensional chromatin compartment in amphioxus indicates a stepwise evolution of vertebrate *Hox* bimodal regulation. *Nat. Genet.*, **2016**, *48*, 336-341.
- [28] Byrne, M; Martinez, P.; Morris, V. Evolution of a pentamer body plan was not linked to translocation of anterior *Hox* genes: the echinoderm *HOX* cluster revisited. *Evol. Dev.*, **2016**, *18*, 137-143.
- [29] Baughman, K. W.; McDougall, C.; Cummins, S. F.; Hall, M.; Degnan, B. M.; Satoh, N.; Shoguchi, E. Genomic organization of *Hox* and *ParaHox* clusters in the echinoderm *Acanthaster planci*. *Genesis*, **2014**, *52*, 952-958.
- [30] Mandelbrot B. B. The Fractal Geometry of Nature. W.H. Freeman & Company **1982**.
- [31] Ferrier, D. E.; Holland, P. W. C. *ParaHox* genes: evolution of *Hox/ParaHox* cluster integrity, developmental mode, and temporal collinearity. *Mol. Phylogenet. Evol.*, **2002**, *24*, 412-417.