

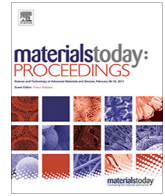

Since January 2020 Elsevier has created a COVID-19 resource centre with free information in English and Mandarin on the novel coronavirus COVID-19. The COVID-19 resource centre is hosted on Elsevier Connect, the company's public news and information website.

Elsevier hereby grants permission to make all its COVID-19-related research that is available on the COVID-19 resource centre - including this research content - immediately available in PubMed Central and other publicly funded repositories, such as the WHO COVID database with rights for unrestricted research re-use and analyses in any form or by any means with acknowledgement of the original source. These permissions are granted for free by Elsevier for as long as the COVID-19 resource centre remains active.



Design and simulation of AI-based low-cost mechanical ventilator: An approach

Jayant Giri*, Niraj Kshirsagar, Aishwary Wanjari

Department of Mechanical Engineering, Yeshwantrao Chavan College of Engineering, Nagpur, Maharashtra 442001 India

ARTICLE INFO

Article history:
Available online 28 May 2021

Keywords:
Mechanical ventilator
COVID 19
MATLAB/Simulink
PEEP
Machine learning
CNN

ABSTRACT

In this situation of COVID 19, many people are being exposed to coronavirus, resulting in difficulty in breathing and a drop in oxygen percentage of blood. A mechanical ventilator is playing a vital role in tackling this situation but the ventilation process is neither readily available nor affordable. The idea behind this work is to propose a simplified design of a mechanical ventilator to reduce the cost and automate the Mechanical ventilation process. The simplified design, its working, and required components are elaborated in this paper. The simulation of the proposed design is made in MATLAB/Simulink platform which is also discussed below. Taking into account the work done in the area of cost reduction of the mechanical ventilation process, the mechanical ventilator with a simplified design comprising of compressed air and oxygen source is being considered. The parameters considered for mechanical ventilation are positive end-expiratory pressure (PEEP), pressure wave, respiratory rate (RR), tidal volume, etc. These parameters of oxygen and air mixture are to be controlled with the help of electronic devices which are pressure regulator, solenoid valve, flow sensor, proportional valve, microprocessor, etc depending upon the condition of patient and type of disease. Simulation results are promising and precise which allows the study on ventilator model without jeopardizing the life of human subjects as in clinical approach and hides the complexity of computational models from the user. Furthermore, advancements in this model are done by the machine learning approach.

© 2021 Elsevier Ltd. All rights reserved.

Selection and peer-review under responsibility of the scientific committee of the Technology Innovation in Mechanical Engineering-2021.

1. Introduction

Mechanical Ventilation is an important process used to provide breathing support to those patients who face inconvenience in natural breathing. This treatment is generally provided in serious lung diseases like Acute respiratory distress syndrome (ARDS), Hypoxemia, Chronic Bronchitis, etc. The goal of mechanical ventilation is to overcome the body's inability to meet the need for adequate oxygen delivery or natural carbon dioxide removal.

The ventilation process must be done with adequate care, a small mistake in the process will cause some serious harm to the patient's alveoli as well as the lung in a broader perspective. It is one of the lifesaving inventions in medical history but right now this technology is very advanced, complex, and expensive. Mechanical Ventilators need a skilled professional to operate them as well as to set the mode and parameters of the mechanical

ventilator according to the condition of the patient. This can be dangerous for the operator, physicist, or medical professional in case of contagious diseases like COVID-19. Thus, it leads to our research as an attempt to find a solution for the drawbacks.

For the cost reduction approach, the BVM (Bag Valve Mask) type of mechanical ventilator is mostly used to construct an emergency portable mechanical ventilator in which a BVM is automated. The BVM (Bag Valve Mask) ventilation is an important tool used in the ventilation of patients in an acute care setting. It is frequently used by respiratory therapists (RTs) during cardiopulmonary resuscitation (CPR), patient transport, rapid response scenarios, and other emergencies. But, due to manual operation, High peak pressures delivered via bag valve mask (BVM) can be dangerous for patients. Manual ventilation with high volume and pressure can cause severe complications for patients, particularly vulnerable patients suffering from Acute Respiratory Distress Syndrome (ARDS), including those infected with COVID-19.

In the research work of Rachel E. Culbreth, the performance of respiratory therapists with different levels of experience in this

* Corresponding author.
E-mail address: jpgiri@ycce.edu (J. Giri).

Nomenclature

ICU	Intensive Care Unit	LCD	Liquid Crystal Display
ET tube	Endotracheal tube	Vt	Tidal Volume
BPM	Breath Per Minute	CNN	Convolutional Neural Network
M.A.	Mechanical Advantage		

field was examined. According to their survey 98, Respiratory therapists were asked to ventilate a BVM for 18 breaths. It was observed that among RTs with more than 10 years of experience, the majority uses BVM 0–5 times per month, which was a higher percentage compared to RTs with less than 10 years of experience. In all participant cases, RTs provided higher tidal volumes, pressures, and flow rates with a lower inspiratory time than ideal. Based on this study it was found that there is an urgent need to create an intervention that allows providers to deliver safe manual ventilation [1].

An attempt was made to automate the mechanism of BVM ventilation by y Abdul Mohsen Al Hussein [2] and S. M. Tamjid Hossain [3], in which a BVM is automated mechanically to construct a portable mechanical ventilator. Cam mechanism, Mechanical arms, and linkages with servo motors were used in that projects to produce the desired motion of the BVM. This design is cheap and easy to implement but this process may cause severe harm to the patient's lungs by causing barotrauma. This design squeezes and releases the Ambu bag with robotic mechanisms but controlling the inspiration pressure accurately is not possible that way. Thus, a different design is considered below.

Many zealous engineers in this unprecedented situation are volunteering to develop a low-cost ventilator that could be built by any suitably adapted manufacturing facility and easily available. One such attempt was made by Badre El Majid whose design comprises a plastic air tank, two wooden or plastic circles, a bendable wire, two check valves, a DC motor, and a guide cylinder. The motor movement causes the wire to bend, which pulls the bottom circle upwards, which tends to pressurize the air inside the tank. This pressurized air is further directed into pipes through the check valve. This state corresponds to the inspiration phase of respiration. Since the pressure in the lungs is higher than the pressure in the air tank, the device will draw air from the patient's lungs. This state corresponds to the expiration phase of respiration. The components will be controlled by a low-cost embedded board such as an Arduino or ESP32 [4]. Although this concept is still under development but provides a promising and inexpensive alternative to Mechanical Ventilator.

The simulation model used was made with MATLAB/Simulink software to provide a computational model to simulate the interaction between the mechanical ventilator and human lungs. The model parallels the hardware and software design of the actual Mechanical Ventilator prototype. It includes all the parameters and variables with help of Simscape libraries which were used while simulating the model. This assists medical professionals in better visualization of the condition and thus helps in decision-making.

The goal of this paper is:

- To design a mechanical ventilator with reduced cost possible by simplifying the design for the mechanical ventilation process.
- To make a simulation model using MATLAB/Simulink software to perform experiments, predict results, and provide a similar interface.

- To automate and simplify the process to replace the need for skilled professionals/therapists for operating patient's conditions on regular basis by providing it with decision-making ability.

2. Methodology

2.1. Materials and methods

The ventilator is connected to the patient through a tube (endotracheal or ET tube) inserted in the mouth or nose into the windpipe. When the doctor inserts the ET tube into the patient's windpipe, the process is termed intubation. Some patients go through the surgical process in their neck and a tube is inserted via the hole created, this process is called tracheostomy. The ventilator blows gas into a person's lungs according to the patient's requirement. It can take over all the respiration processor can assist the patient to breathe. The ventilator can provide a positive end-expiratory pressure (PEEP pressure) which helps to hold the lungs open, so the air sacs don't collapse. The ventilator should stop delivering oxygenated air as soon as the patient starts to breathe himself. If it operates while the respiratory system of the patient is active it may cause damage to the lungs and can cause serious injury to the lung (VILI). Thus, there must be a system to monitor when the patient starts to breathe by himself naturally and stop the operation of the ventilator.

The basic goals of Ventilation are:

- To assist with minute ventilation to remove CO₂.
- To provide FiO₂ (Fraction of Inspired O₂) and maintain End-expiratory lung volume with Positive end-expiratory pressure (PEEP), to maintain Oxygenation.

From the study, it has been found that while using the ventilator there are some basic settings that the operator needs to use before the use of a ventilator, some of these settings are Mode, Tidal Volume, Frequency (Rate), FiO₂, Flow Rate, I: E Ratio, Sensitivity, PEEP, Alarms. Various diseases were observed among patients which require them to be supported by Mechanical Ventilation which are Emphysema, Pneumothorax, ARDS, Pneumonia, Asthma, Anaphylaxis, Reduced lung Compliance, Chronic Obstructive Pulmonary Disease (COPD), Chronic Bronchitis, Cystic Fibrosis/ Bronchiectasis, Lung Cancer, Hypoxemia.

2.2. Modes of ventilation

Different modes of mechanical ventilation are listed below:

- Volume Control (VC)
- Pressure Control (PCV)
- Pressure Support (PSV)
- Continuous Positive Airway Pressure (CPAP)
- Proportional Assist Ventilation (PAV)
- Pressure Regulated Volume Control (PRVC)
- Volume Support

• Airway Pressure Release Ventilation (APRV)

The study of different modes is widely discussed in the literature [5] and [6]. But this design is mainly focused on only PSV and VCV mode initially, other modes can be implemented in further advancements to be done in the design. The ideal waveforms of pressure and volume-controlled ventilation are shown in Fig. 1 [7].

2.3. Minimum settings and targets

- FiO2 (Fraction of Inspired Oxygen) can be minimum set to value 0.21 which is equal to oxygen percentage in atmospheric air.
- PEEP (Positive End Expiratory Pressure) is usually set to 5 cm H2O. The value of PEEP should not exceed 10 cm of H2O. A value below 5 cm of H2O is perfectly fine.
- Tidal Volume = 6 to 8 mL/kg of ideal Body Weight. Ideal body weight is calculated based on height, age, and gender.
- RR (Respiratory Rate) is set according to this formula.
- RR = predicted value of VE (Minute Ventilation)/Tidal volume.
- Minute Ventilation (VE) Predicted value = 100ML/min × ideal Body Weight (kg) The ideal value of Plateau pressure Pplat < 30 cm of H2O.

2.4. Proposed design of mechanical ventilator

To control the parameters of compressed air and oxygen mixture like flow, pressure, the fraction of inspired oxygen (FiO2), respiration rate, I: E ratio, etc., components like a pressure regulator, proportional valve, pressure sensors, flow sensors, etc. are used. The functioning of these components is monitored and controlled by the control unit to perform mechanical ventilation properly. The actual design of a mechanical ventilator is too complicated and thus it is very costly. The block diagram of simplified design is shown in Fig. 2.

The outline of the working of design is elaborated further. Initially, the compressed air and oxygen are first mixed in particular proportion with the help of proportion valves. Further, the pressure regulator is used to control the pressure of the gas mixture

according to the mode of mechanical ventilator depending on the patient’s condition. Then the solenoid valves will open and close simultaneously in a particular time cycle and control the inspiration and expiration of the gas mixture. The sensors like pressure sensors and flow sensors are used to measure the pressure and flow of the gas mixture respectively and display those readings on the screen so that the respiratory therapist would be able to monitor the condition of the patient whenever necessary.

2.5. Components

The components to be used in this design are listed below: Table 1.

2.6. Diagram

3. Simulation model of mechanical ventilator

Simulation software like MatLab/Simulink, LabVIEW helps us in developing system-design platforms as well as development environments which helps us in predicting outcomes of the research or project with better visualization and accuracy. Mathematical expressions are used to present Mathematical Models (MM) or Computational Models (CM), these models aid in performing simulations under various conditions and varied parameters. Experimentations done on Mechanical Ventilators are not only very costly but also threatens the patient’s life. While developing computational mathematical models of the mechanical ventilation process, simulation plays an important role in testing novel modes of ventilation along with conventional modes such as Volume Control Mode (VCM) and Pressure Control Mode (PCM).

Modeling and Simulation of a system are nowadays very important in the biomedical engineering domain as the models representing actual systems are precise. The versatility provided by software helps us to analyze a variety of parameters such as type of patient or type of disease, etc. thus, saving human lives. The simulation model provided below is of a Positive-pressure medical

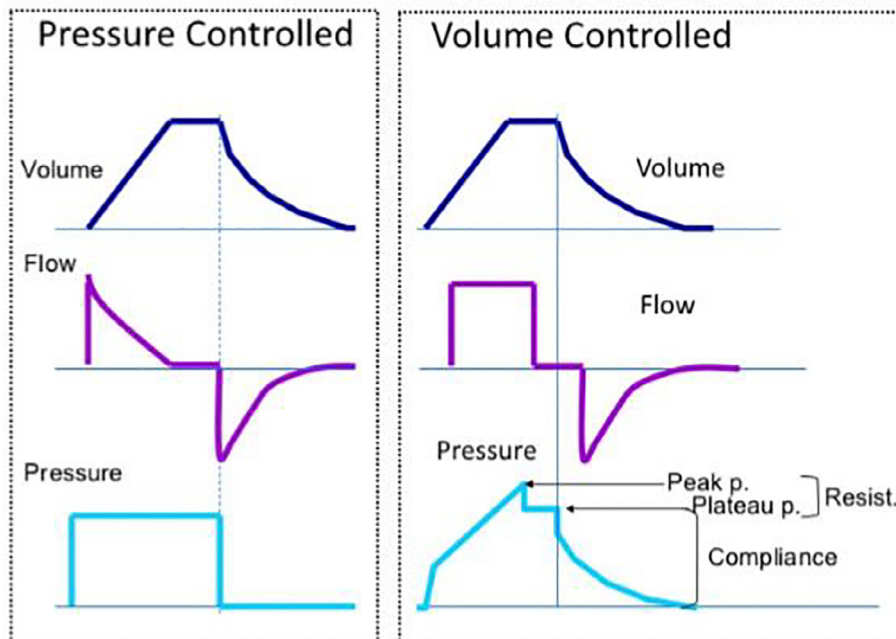
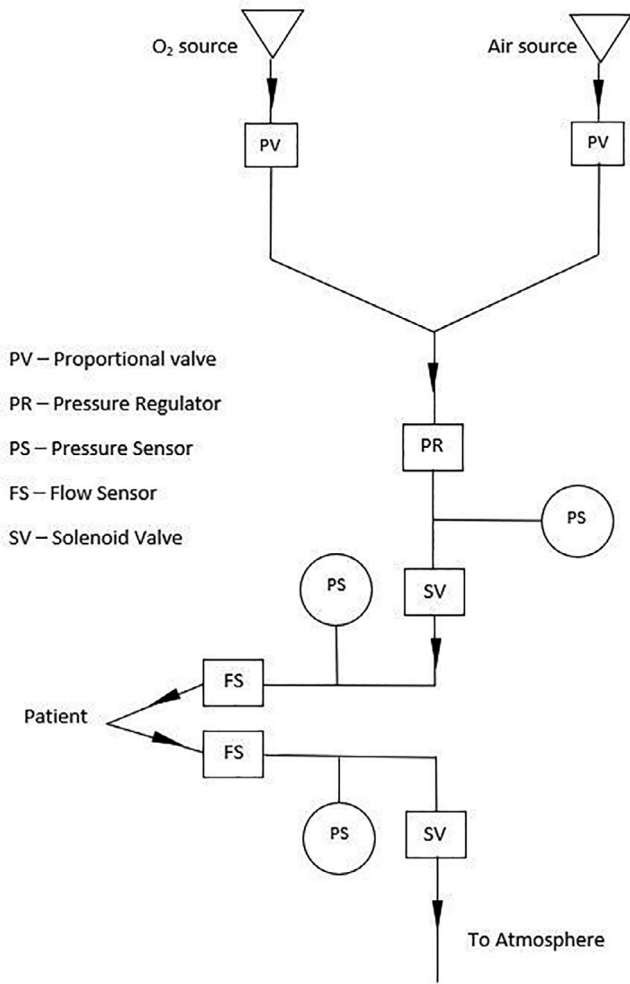

Fig. 1. Waveform of controlled ventilation modes [7].



PV – Proportional valve
 PR – Pressure Regulator
 PS – Pressure Sensor
 FS – Flow Sensor
 SV – Solenoid Valve

Fig. 2. Schematic Block diagram of a simplified design of mechanical ventilator [6].

Table 1
 Components of the proposed design.

Component	Range	Quantity
Compressed Air and O2 Source	2000–6000 cmH2O	–
Pressure Regulator	0.001–0.1 MPa	1
Proportional Valve	–	2
Pressure Sensor	1 and 5 PSI	3
Solenoid Valve	20 Hz	3
Flow Sensor	0–10 L/min	2
Tubes	~22 mm	according to the requirements
Wires	–	according to the requirements
Computer System	raspberry Pi 4 model B	1
Pulse Oximeter	–	1
Display unit	–	1
Alarm System	–	1

ventilator system by Mathworks Resources [8]. The model includes the patient’s lungs, the ventilator device with valves and tubes as well as a pressure-targeted ventilator controller. In this model, a pre-set flow rate is supplied to the patient. The lungs are also modeled by Translational Mechanical Converter which in turn converts the moist air pressure into translational motion. The simulation results are obtained by Simscape Logging where the temperature and relative humidity of air flowing through the inspiratory and

expiratory tubes are shown. It defines how to interface a real-time controller and a system model in Simulink and State flow as well as how a design process is supported by a full system model [8] (Fig. 3).

The mathematical expression of positive pressure type of ventilation is referred to as the equation of motion. The equation of motion is given below [9]:

$$P(t) = E.V(t) + R.V(t) \tag{1}$$

P: Pressure, R: Airway Resistance, E: Lung Elastance, V: Tidal Volume, ΔV: Volumetric Flow

The steady-state exchange of CO₂ in arterial blood is expressed by the following mathematical expression:

$$PaCO_2 = PiCO_2 + 863 * V * CO_2 \tag{2}$$

V'E (1 – VD/VT)
 PiCO₂: Inhaled carbon dioxide
 V'CO₂: Metabolic CO₂ output
 V'E: Total ventilatory output
 VD: Respiratory dead space
 VT: Tidal volume

Simulation results are found by the Simscape logging method (Fig. 4). This graph shows the temperature and relative humidity of air flowing through the inspiratory and expiratory tubes. Before being supplied to the patient, room air is heated and humidified. The water comes from the humidifier and the patient’s respiration. The accumulation of condensed water in the expiratory tube should be drained from time to time for better results.

The Matlab/Simulink and Simscape libraries contain physical modeling blocks which were used while creating the simulation models. This helps to simulate the interaction between the ventilator components and the mechanics of the human lungs. A special model library for mechanical ventilation has been made available in the Simscape Programming language for further computation. The controller coefficients use the closed-loop control of the mechanical ventilation process and then the variables are transferred to the embedded software system. The model is optimized according to the parameters like PEEP, PIP, I/E ratio, etc. The model comprises four major parts: the controlled system, the feedback paths, the controller, and the actuator [10].

The interaction between the patient and the ventilator comprises various subsystems. The ventilator configuration, as well as modes, plays a major role in deciding the output. The kind of respiratory disease, patient’s history for that particular disease, type of human being race and the effectivity of treatment, etc parameters contribute to the patient-ventilator interaction. The block diagram given above shows the flow of interaction between patient and ventilator. The respiratory pathologist monitors the patient activity by computing the levels of Elastance and Resistance. The simulator acts on the input and helps in setting control parameters as well as Ventilator modes. The embedded system does the calculation of ventilatory parameters and variables. Thus, the result is displayed according to the pressure, volume and flow required. Thus, simulation can investigate varied conditions and predict outcomes accordingly without any danger or loss to human life.

4. Result and discussion

From the historical use of negative pressure Ventilator devices to modern positive pressure mechanical Ventilators, it has been a very crucial part of medical science. Advancements in biomedical engineering have developed the functionalities of ventilators. As a result, it has been an expensive treatment. Due to the rapid increase in demand for mechanical ventilators in the COVID-19

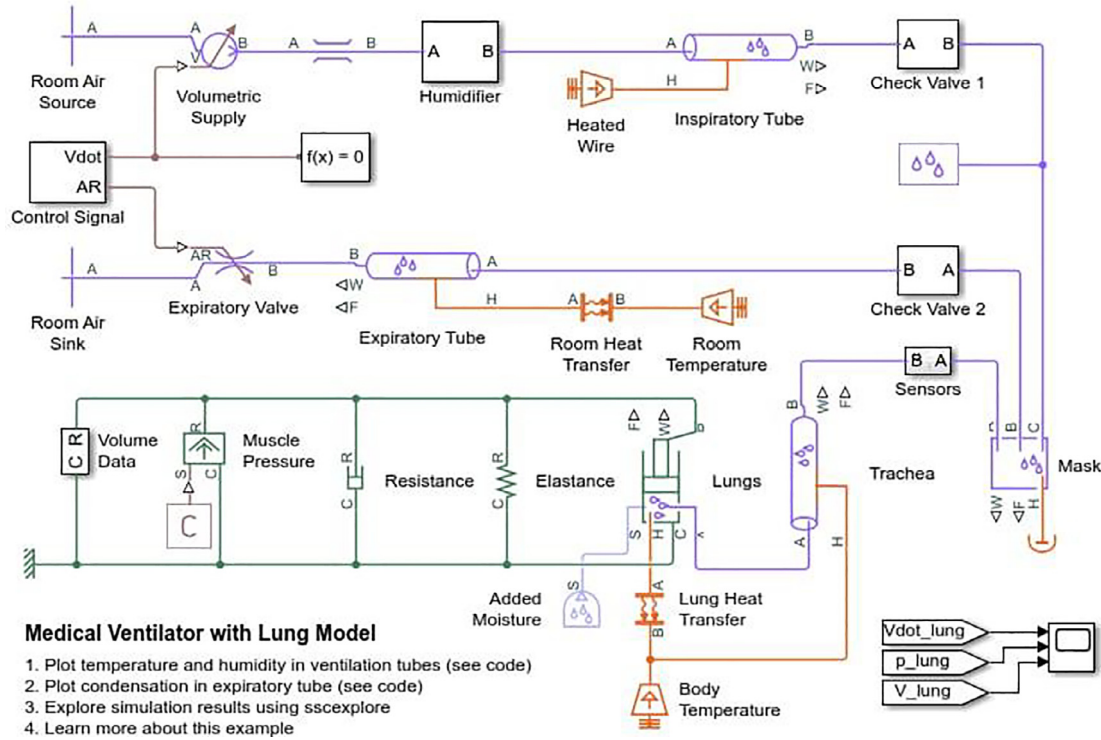

Fig. 3. A simulation model of Mechanical Ventilator and Lungs [8].

pandemic, people with economically poor backgrounds find it difficult to afford the treatment. Also, the fees of medical professionals or therapists add monetary value. This research and low-cost approach would help in making the Mechanical Ventilator available for financially backward people. The simulation model of the mechanical ventilator is created to mimic the working of mechanical ventilation with help of mathematical models. The results are quite similar to that of actual Ventilators. Simulation provides the freedom to study or experiment on a range of parameters or variables without any human life in danger. Also, the neural networks provide the model decision-making ability which will either assist the medical professionals in decision making or com-

pletely replace the need for human presence for monitoring patients.

The concept is still under development. We will consider changes induced by the results of the prototype testing. Many cost-effective sensors that interact with the human body and ensure the accurate administration of respiration will also be added. Microcontrollers like Arduino will be used along with the simulated model for smooth conduction of the ventilation process.

Fig. 5 shows the simulation result of the ventilator model which is obtained by using a Simulink tool called 'Scope'. The outputs of the measured signal using sensors are attached to the scope block

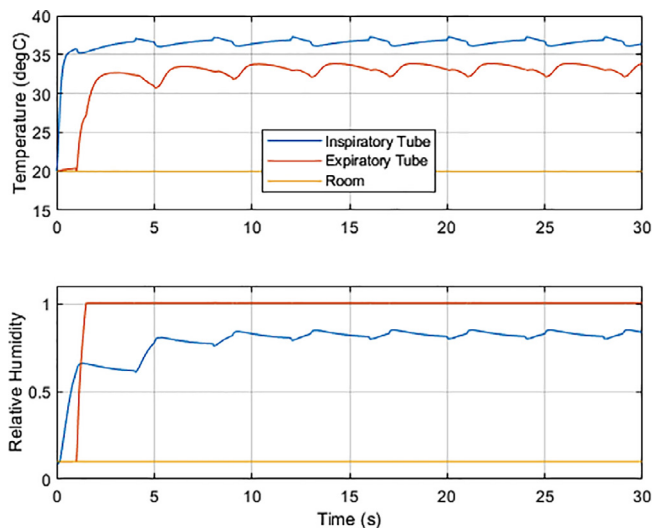

Fig. 4. Temperature and relative humidity of air flowing through the inspiratory and expiratory tubes [8].

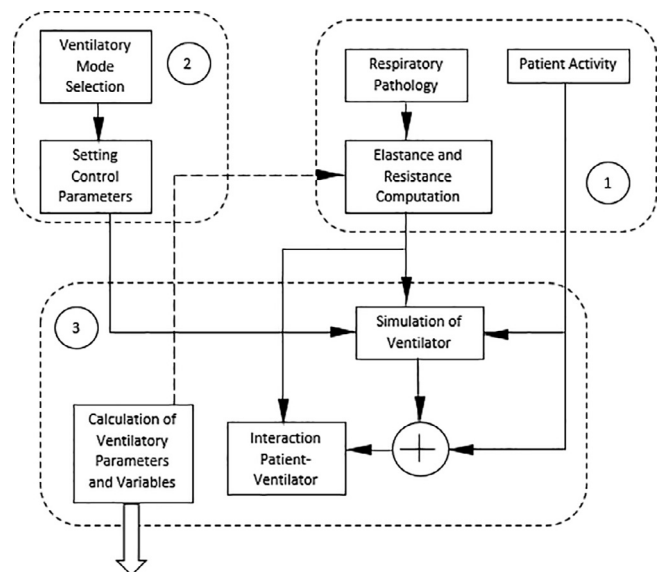

Fig. 5. Block diagram of Patient- Ventilator Interaction [10].

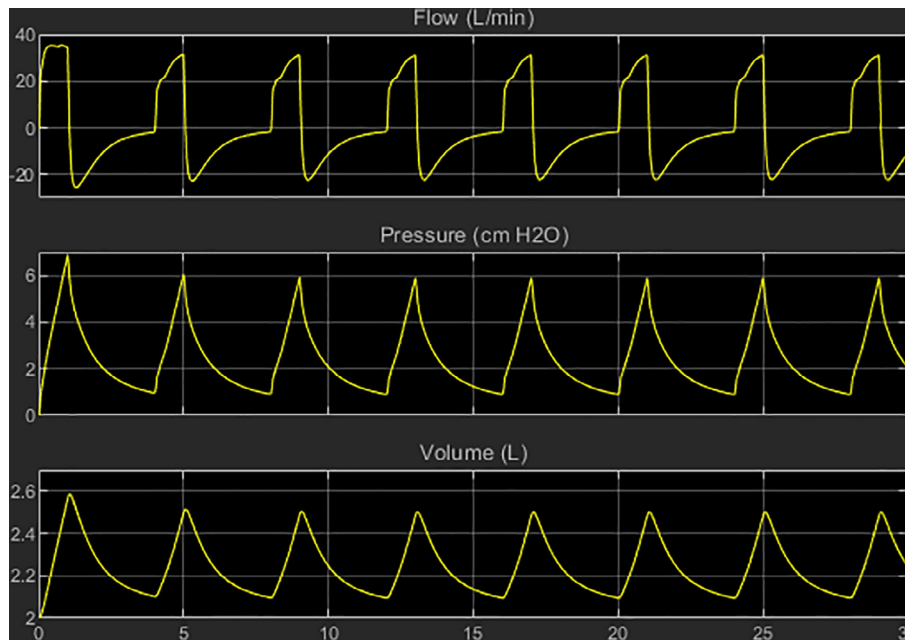

Fig. 6. Simulation result of the ventilator model using Scope tool [8].

as input and the scope tool plots the graph of the results obtained. The results are quite similar to that of the actual mechanical ventilator (Fig. 6).

5. Conclusion

Mechanical Ventilation is a very critical and delicate process that needs to be done precisely as a single mistake can cost the patient his/her life. Thus, the operation is done by skilled professionals or therapists and the on-time decisions taken are mostly based on experience. Thus, automating the process is very beneficial as it can control the modes and parameters according to the conditions and training neural networks. Simulation and computational models can mimic the real-life medical clinical situation and thus reduce the human intervention by assisting the medical professionals with its wide range of functionality and usage. Simulation is becoming an essential field in biomedical engineering and can be used not only for treatment but also for experimenting on diseases or patients. The same is applied to a mechanical ventilator and the human respiratory system. The MATLAB/Simulink model simulates the interaction between human lungs and mechanical ventilators. Thus, operations could be performed on it and results could be seen on the graphical interface provided which will help therapists to make informed decisions. Mechanical ventilators used currently are very complex which leads to an increase in the cost of the ventilation process. Thus, simplification of the design, simulation, and artificial intelligence approach will reduce the cost. Introducing Mechanical Ventilator to artificial intelligence can provide it with decision-making ability which is absent in normal Ventilators. This can save the lives of physicians and respiratory therapists from contagious respiratory diseases like covid 19.

The simulation model has graphical features similar to a mechanical ventilator which eases the human-ventilator interaction. The system covers about every parameter and function provided by the actual ventilator along with a complex model of the respiratory control system. The tool has shown promising results and can be used for training purposes. The system completely validates the experimental data taken from an actual mechanical ventilator. More functions and modes can be added to make the model

more precise. Currently, our work is more focused on optimizing the model with the artificial neural network to provide it the decision-making ability.

CRedit authorship contribution statement

Jayant Giri: Conceptualization, Methodology, Writing - original draft, Investigation. **Niraj Kshirsagar:** Writing - original draft. **Aishwary Wanjari:** Validation, Visualization, Software, Supervision.

Declaration of Competing Interest

The authors declare that they have no known competing financial interests or personal relationships that could have appeared to influence the work reported in this paper.

References

- [1] R.E. Culbreth, D.S. Gardenhire, *Manual Bag Valve Mask Ventilation performance Among RESPIRATORY*, Elsevier, 2020.
- [2] A.M. Al Hussein, H.J. Lee, J. Negrete, S. Powelson, A. Servi, A. Slocum, J. Saukkonen, *Design and Prototyping of a Low-cost Portable Mechanical, Proceedings of the 2010 Design of Medical Devices Conference*, 2010.
- [3] S.M.T. Hossain, M.R. Halder, A. Aman, M.R. Islam, M.T. Rahman, *Design Construction and Performance Test of a Low-Cost Portable Mechanical Ventilator for, International Conference on Mechanical, Industrial and Energy Engineering*, 2018.
- [4] B.E. Majid, A.E. Hammoumi, S. Motahhir, A. Lebbadi, A.E. Ghzizal, *Preliminary design of an innovative, simple, and easy-to-build, Euro-Mediterranean J. Environ. Integr.* (2020).
- [5] I. Grossbach, L. Chlan, M.F. Tracy, *Overview of mechanical ventilatory support and management of patient- and ventilator-related, CriticalCareNurse* (2011).
- [6] H. Guler, I. Turkoglu, F. Ata, *Designing Intelligent Mechanical Ventilator and User Interface*, 2012.
- [7] F.S. Sayin, H. Erdal, *Design, Modelling, Prototyping and Closed Loop Control of a Mechanical Ventilator for Newborn Babies, 2018 6th International Conference on Control Engineering & Information Technology (CEIT)*, 2019.
- [8] Mathworks, [Online]. Available: <https://in.mathworks.com/help/phymod/simscape/ug/medical-ventilator-with-lung-model.html>.
- [9] R.L. Chatburn, E. Mireles-Cabodevila, *Closed-loop control of mechanical ventilation: description and classification of targeting schemes, Respiratory Care* (2011).
- [10] L.Y. Serna, A.M. Hernandez, M.A. Mañanas, *Computational Tool for Modeling and Simulation of Mechanically Ventilated Patients, Annual International Conference of the IEEE Engineering in Medicine and Biology Society*, 2010.