

Topographic Localization of the Heparin-binding Domain of the Neural Cell Adhesion Molecule N-CAM

Gregory J. Cole, Arleen Loewy, Nancy V. Cross, Richard Akeson,* and Luis Glaser

Department of Biological Chemistry, Division of Biology and Biomedical Sciences, Washington University School of Medicine, St. Louis, Missouri 63110; and *Division of Cell Biology, Children's Hospital Research Foundation, Cincinnati, Ohio 45229. Dr. Cole's present address is University of Miami School of Medicine, Department of Biochemistry, Miami, Florida 33101. Dr. Glaser's present address is University of Miami, Coral Gables, Florida 33124.

Abstract. Previous studies have reported that the cell-binding region of the neural cell adhesion molecule (N-CAM) resides in a 65,000-D amino-terminal fragment designated Frl (Cunningham, B. A., S. Hoffman, U. Rutishauser, J. J. Hemperly, and G. M. Edelman, 1983, *Proc. Natl. Acad. Sci. USA*, 80:3116–3120). We have reported the presence of two functional domains in N-CAM, each identified by a specific mAb, that are required for cell–cell or cell–substratum adhesion (Cole, G. J., and L. Glaser, 1986, *J. Cell Biol.*, 102:403–412). One of these domains is a heparin (heparan sulfate)–binding domain. In the present study we have determined the topographic localization of the heparin-binding fragment from N-CAM, which has been identified by our laboratory. The B₁A₃ mAb recognizes a 25,000-D heparin-binding fragment derived from chicken N-CAM, and also binds to a 65,000-D fragment, presumably Frl, produced by digestion of N-CAM with *Staphylococcus aureus* V8

protease. Amino-terminal sequence analysis of the isolated 25,000-D heparin-binding domain of N-CAM yielded the sequence: Leu-Gln-Val-Asp-Ile-Val-Pro-Ser-Gln-Gly. This sequence is identical to the previously reported amino-terminal sequence for murine and bovine N-CAM. Thus, the 25,000-D polypeptide fragment is the amino-terminal region of the N-CAM molecule. We have also shown that the B₁A₃ mAb recognizes not only chicken N-CAM but also rat and mouse N-CAM, indicating that the heparin-binding domain of N-CAM is evolutionarily conserved among different N-CAM forms. Additional peptide-mapping studies indicate that the second cell-binding site of N-CAM is located in a polypeptide region at least 65,000 D from the amino-terminal region. We conclude that the adhesion domains on N-CAM identified by these antibodies are physically distinct, and that the previously identified cell-binding domain on Frl is the heparin-binding domain.

THE specific recognition between neuronal cell types is of critical importance during neural development. Cell–cell interactions have been the focus of many recent studies, and several distinct cell surface molecules have been implicated in neuronal cell–cell adhesion. These molecules include the neural cell adhesion molecule N-CAM (10, 13, 17, 23, 29), neuron–glial cell adhesion molecule (Ng-CAM) (11), L1 (21), and the nerve growth factor–inducible large external (NILE) glycoprotein (28). N-CAM is the best characterized neural cell adhesion molecule to date, and has been implicated in neuron–neuron (24, 25, 29), neuron–muscle (12), and neuron–glial (18, 27) adhesion. Previous studies have examined the relationship between the chemical properties of N-CAM and its function, and have shown that a site required for homophilic binding of N-CAM (14) is localized to the amino-terminal region of the molecule (9).

Studies in our laboratory have characterized a neural cell adhesion molecule that has now been identified as N-CAM (3–7). Using monoclonal antibodies, we have characterized the role of N-CAM in neuronal cell interactions. The B₁A₃

mAb, which inhibits cell–cell adhesion, recognizes a 25,000-D polypeptide fragment from N-CAM that binds specifically to heparin or heparan sulfate (5). We have also demonstrated that heparin or heparan sulfate can inhibit N-CAM–mediated cell interactions (5, 6). A second mAb (C₁H₃) also inhibits N-CAM–mediated cell–cell or cell–substratum adhesion but does not bind to the 25,000-D fragment. In the present study we were interested in determining the topographical localization of the heparin-binding domain and how it may be related to the location of the cell-binding domain. Our data indicate that the heparin-binding domain is localized to the 25,000-D amino-terminal region of the N-CAM molecule.

Materials and Methods

Preparation of mAb's

The preparation and characterization of the B₁A₃ mAb (5), as well as other mAb's (3), has been described previously. The B₁A₃ mAb was produced by immunizing BALB/c mice with immunopurified N-CAM. The B₁A₃ and

C₁H₃ antibodies react with different epitopes, since they do not inhibit the binding of each other to N-CAM. Neither antibody binds to carbohydrate, each reacts with protein isolated from cells labeled with [³⁵S]methionine for 30 min, as described in reference 3, or with N-CAM synthesized by retina cells in the presence of tunicamycin.

Immunopurification of N-CAM

N-CAM was immunopurified from embryonic day 14 chicken brain tissue as previously described (7). Briefly, for each purification 100–200 brains were removed and homogenized in calcium–magnesium-free Hanks' solution, and a membrane fraction was isolated. The membranes were then solubilized in PBS containing 1 mM EDTA and 0.5% NP-40 (pH 8.3). C₁H₃ mAb, which reacts with N-CAM (5), was coupled to cyanogen bromide-activated Sepharose 4B (~5–7 mg/ml). The solubilized extract of brain membranes was then incubated with the C₁H₃-Sepharose, and bound protein was eluted with PBS/1 mM EDTA/0.5% NP-40 containing 0.05 M diethylamine (pH 11.5).

Preparation of Heparin-binding Domain from N-CAM

The heparin-binding domain was prepared from N-CAM by proteolytic digestion of immunopurified N-CAM with subtilisin protease (5). For amino-terminal sequencing of the heparin-binding domain, 2 mg of N-CAM was incubated with 40 µg of subtilisin protease (Sigma Chemical Co., St. Louis, MO) at 37°C for 1 h. Proteolysis was then stopped by the addition of phenylmethylsulfonyl fluoride (PMSF) and aprotinin (Sigma Chemical Co.). The digested N-CAM (in 0.1× PBS) was then incubated with 1.5 ml of heparin-agarose (Sigma Chemical Co.) for 1.5 h at room temperature, and packed into a column. After washing with 0.1× PBS, the heparin-binding fragment was eluted with 0.5 M NaCl.

Immunoblotting Analysis of N-CAM

To determine if the B₁A₃ mAb recognized a similar epitope in rat N-CAM, rat or chicken N-CAMs were digested with subtilisin protease (1:50 enzyme/substrate ratio) and electrophoresed on 10% polyacrylamide gels. The proteolytic fragments were then transferred to nitrocellulose and reacted with B₁A₃ mAb as previously described (3, 5). mAb binding was visualized using the avidin–biotin conjugate method (Vector Laboratories, Inc., Burlingame, CA).

Amino-terminal Sequencing of Isolated Heparin-binding Domain

After isolation of the heparin-binding domain, the 25,000-D fragment was electrophoresed on a 10% polyacrylamide mini-gel and stained with Coomassie Blue for 10 min. The gel was then rapidly destained (15), and the bands corresponding to the 25,000-D fragment were cut from the gel. The gel fragments were then processed for electroelution as described by Hunkapiller et al. (15). Alternatively, we transferred the 25,000-D fragment to polybrene-coated glass fiber filters (30). We initially attempted to obtain sequence analysis by electroblotting the 25,000-D fragment onto activated glass filter paper (1), but the fragment did not transfer out of the gel onto the glass filter paper. We thus initially used the electroelution method to obtain sequence information and then confirmed the amino-terminal sequence by transfer of the 25,000-D fragment to polybrene-coated glass fiber filters. After electroelution of the 25,000-D fragment or identification of the fragment on the glass fiber paper, amino-terminal sequence analysis was performed on a vapor phase sequencer (model 470A; Applied Biosystems, Inc., Foster City, CA) with identification of the phenylthiohydantoin amino acids on an on-line phenylthiohydantoin analyzer (model 120A; Applied Biosystems, Inc.).

Results

Cunningham et al. (9) demonstrated that a 65,000-D polypeptide fragment could be derived from N-CAM by autodigestion of N-CAM, and that this fragment (named Fr1) could inhibit N-CAM-mediated cell binding. This fragment could also be isolated by digestion of N-CAM with *Staphylococcus aureus* V8 protease (14), and it was shown that the amino-terminal amino acid sequence of Fr1 was identical to

the intact protein (9). It was therefore concluded that the cell-binding domain of N-CAM was localized to the amino terminus of the molecule.

In the present study we were interested in determining the topographical localization of the heparin-binding domain of N-CAM. Our laboratory has shown that heparin or the physiologically relevant ligand heparan sulfate are involved in N-CAM-mediated cell–cell interactions (5, 6). It has also been demonstrated that N-CAM undergoes a conformational change after the binding of heparan sulfate (7). Therefore, it is of interest to examine how the alignment of the heparin-binding domain on the linear sequence of the N-CAM molecule is related to the cell-binding region.

Our initial studies regarding the binding characteristics of the B₁A₃ mAb, which recognizes the heparin-binding domain of N-CAM, showed that the B₁A₃ mAb reacts with a 65,000-D polypeptide fragment that is converted to the 25,000-D fragment with more extensive protease treatment (5). We were therefore interested in determining if the 65,000-D Fr1 fragment was identical to the fragment recognized by the B₁A₃ mAb. In preliminary experiments, we attempted to obtain the Fr1 fragment by autodigestion of N-CAM at 37°C, as described by Edelman and co-workers (9). We only obtained limited amounts of the Fr1 fragment, which suggests that our N-CAM preparations do not contain significant quantities of protease activity; however, the Fr1 fragment that we generated reacted with the B₁A₃ mAb (data not shown). To obtain more direct evidence that the B₁A₃ mAb recognized the cell-binding domain of N-CAM, we treated N-CAM with *S. aureus* V8 protease and then performed an immunoblotting analysis (Fig. 1). As shown in Fig. 1, lane a, when N-CAM is reacted with subtilisin protease and then incubated with B₁A₃ mAb, both 65,000- and 25,000-D polypeptide fragments are detected. After longer incubations with subtilisin protease, the 25,000-D fragment is the only fragment to which the B₁A₃ mAb can bind (5). Likewise, when N-CAM is digested with V8 protease, the B₁A₃ mAb reacts with a 65,000-D fragment, which is presumably the Fr1 fragment of N-CAM. These data therefore indicate that the heparin-binding domain of N-CAM is probably localized to the 65,000-D amino-terminal region of the N-CAM protein, and raises the question of whether the cell-binding domain is identical to the heparin-binding domain.

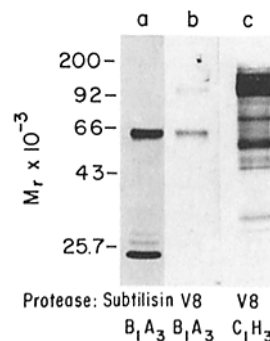

Figure 1. The B₁A₃ mAb binds to the Fr1 fragment of N-CAM. 10-µg aliquots of N-CAM were incubated at 37°C with 100 ng of subtilisin (lane a) or *S. aureus* V8 protease (lanes b and c) for 30 min. Proteolysis was then inhibited by the addition of PMSF, and the N-CAM fragments were electrophoresed on a 10% gel, transferred to nitrocellulose, and reacted with B₁A₃ or C₁H₃ mAb. The nitrocellulose was then incubated with biotinylated secondary antibody and Vectastain ABC reagent (Vector Laboratories, Inc.). Antibody binding was visualized by reaction with diaminobenzidine. Note that the B₁A₃ mAb reacts with the 65,000-D Fr1 fragment.

Table I. Amino Acid Sequence Analysis of Heparin-binding Domain from N-CAM

	Amino acid sequence	Reference
25,000-D fragment	Leu-Gln-Val-Asp-Ile-Val-Pro-Ser-Gln-Gly	
Amino terminus, N-CAM	Leu-Gln-Val-Asp-Ile-Val-Pro-Ser-Gln-Gly-Glu-Ile-Ser-Val-Gly-Glu-Ser	22

The amino acid sequence of the 25,000-D heparin-binding fragment was determined as described under Materials and Methods. The sequence is shown through the first 10 residues, although cycles 11-15 yielded a low level sequence that also matched the amino-terminal sequence of N-CAM. Three independent analyses were performed.

Our data in Fig. 1 also show that the C₁H₃ mAb, which inhibits cell-substratum and cell-cell adhesion (4-6), reacts with a polypeptide fragment distinct from Fr1. Since the C₁H₃ mAb does not bind to Fr1, these data suggest that the C₁H₃ mAb binding site must be at least 65,000-D from the amino terminus of N-CAM. These data also imply that at least two functional domains may exist on N-CAM and that the C₁H₃ mAb might bind to a region of the N-CAM molecule that participates in homophilic binding.

To determine whether the heparin- and cell-binding domains are both localized to the amino-terminal region, we performed amino-terminal amino acid sequence analysis of the isolated heparin-binding domain. As shown in Table I, the amino acid sequence obtained for the 25,000-D fragment is Leu-Gln-Val-Asp-Ile-Val-Pro-Ser-Gln-Gly, which is identical to the previously reported amino-terminal sequence for N-CAM (22). Thus, these data indicate that the heparin-binding domain of N-CAM is localized within the 25,000-D of the amino-terminal region of the molecule.

Rougon and Marshak (22) produced antibodies that recognized a synthetic peptide sequence derived from the amino-terminal sequence of murine and bovine N-CAM. These antibodies cross-reacted with N-CAMs from a variety of species, which indicated that the amino-terminal domain is highly conserved. Since the B₁A₃ mAb recognizes the heparin-binding domain from N-CAM and also blocks heparin binding to N-CAM, as well as the adhesive function of the molecule, and the heparin-binding domain is localized to the amino-terminal region of N-CAM, we asked whether this domain is also conserved among different N-CAM species. To test this possibility, rat N-CAM was digested with subtilisin protease, transferred to nitrocellulose, and immunoblotted with B₁A₃ mAb. As shown in Fig. 2, the B₁A₃ mAb reacts with 25,000-D polypeptide fragments obtained from both chicken and rat N-CAM. However, reaction of the mAb with rat N-CAM is weaker than with chicken N-CAM, which suggests that the epitopes may not be identical in both

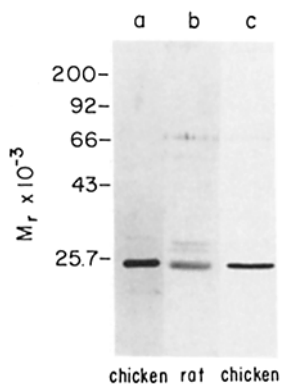

Figure 2. The heparin-binding region (B₁A₃ epitope) of N-CAM is a conserved structural and functional domain. 10- μ g aliquots of immunopurified chicken (lanes a and c) or rat N-CAM (lane b) were incubated with 200 ng of subtilisin protease for 1 h at 37°C. The proteolytic fragments were then analyzed by immunoblotting using the B₁A₃ mAb (lanes a and b) or an anti-rat N-CAM antiserum (lane c) as described in Fig. 1.

species. In Fig. 2 it can also be seen that when chicken N-CAM is digested with subtilisin protease and blotted with an anti-rat N-CAM antiserum, only the 25,000-D fragment is stained (Fig. 2, lane c). These data suggest that the most highly conserved region of chicken N-CAM, as detected by the anti-rat N-CAM antiserum, is the 25,000-D heparin-binding fragment. Alternatively, this fragment may be the most protease-resistant region of the N-CAM molecules when treated with subtilisin protease.

To confirm that the heparin-binding domain is a conserved structural and functional domain among various N-CAM forms, we used the B₁A₃ mAb to immunopurify N-CAM from metabolically labeled BC₃H1 cells. The BC₃H1 cell line is a mouse muscle-like cell line, and produces N-CAM (8). Fig. 3 shows the results of an experiment involving the metabolic labeling of cultures of BC₃H1 cells that were grown in 20% FCS and thus were undifferentiated (20). Although the B₁A₃ mAb did not immunopurify significant quantities of labeled N-CAM from a BC₃H1 cell extract, labeled N-CAM was isolated from the conditioned medium of the BC₃H1 cells (Fig. 3). These data indicate that the heparin-binding domain is conserved in mouse N-CAM, and also suggest that muscle cells (at least the BC₃H1 cell line) may secrete larger amounts of N-CAM into the extracellular matrix than do neural cells. We have also analyzed N-CAM, immunopurified from adult mouse brain or BC₃H1 cells using B₁A₃ mAb, by immunoblotting using the anti-rat N-CAM antiserum. These experiments showed that small amounts of N-CAM could be isolated from these cells using the B₁A₃ mAb (data not shown). The reason why only small amounts of N-CAM are isolated may be the low cross-reactivity between mouse N-CAM and the B₁A₃ mAb.

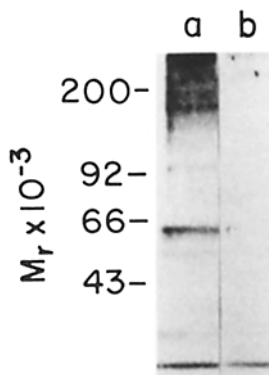

Figure 3. Identification of the B₁A₃ epitope in mouse N-CAM. Long-term cultures of BC₃H1 cells were grown in culture as described under Materials and Methods. Cells were then labeled overnight in methionine-free medium containing 1% FCS and 100 μ Ci/ml of [³⁵S]methionine. Conditioned medium from the cultures was mixed with an equal volume of PBS containing 1% Triton X-100, and incubated overnight with either

B₁A₃ or control ascites coupled to Sepharose 4B. The labeled protein retained on the columns was then analyzed on an 8% polyacrylamide gel. Lane a, labeled protein isolated using B₁A₃-Sepharose; lane b, material eluted from the control ascites column. The high molecular weight smear of labeled protein represents immunopurified N-CAM protein.

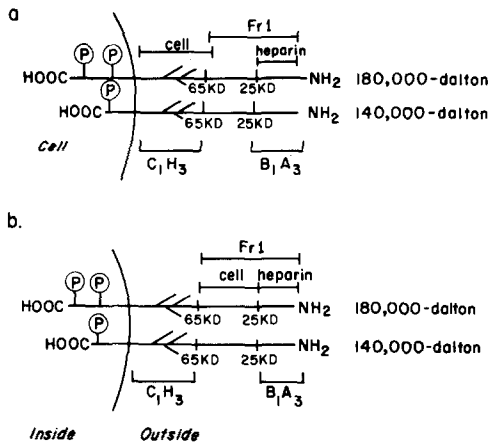

Figure 4. Linear model depicting the localization of the heparin- and cell-binding domains of N-CAM. In *a*, the heparin-binding domain is aligned at the amino terminus of the N-CAM molecule, and the cell-binding domain is aligned in the carbohydrate-containing region of N-CAM. This is the putative C₁H₃ mAb-binding region. Thus, the cell- and heparin-binding domains are physically distinct regions of the N-CAM molecule (see text for a more detailed description). In *b*, the model is constructed based on data from this study and Cunningham et al. (9). The only difference from the model in *a* is that the cell-binding domain is also aligned in the Fr1 fragment, and is immediately adjacent to the amino-terminal heparin-binding domain.

In light of these data demonstrating that the heparin-binding domain of N-CAM is localized in the amino-terminal region of the N-CAM molecule, we have constructed a linear model of the N-CAM molecule (Fig. 4). Because our C₁H₃ mAb, which inhibits N-CAM-mediated cell-cell interactions, recognizes an epitope distinct from the B₁A₃ epitope (Fig. 1, lane *c* and reference 5), we have assigned the cell- or homophilic-binding domain to a more internal region of the N-CAM molecule (Fig. 4 *a*). However, it is possible that the cell-binding domain described by Edelman's laboratory (9) is also contained in the amino-terminal region of the N-CAM molecule (Fig. 4 *b*) and additional studies should provide information regarding the precise location of this functional domain.

Discussion

Our aim in the present study was to examine the relationship between the structure and function of the heparin-binding domain of N-CAM. Previous studies in our laboratory demonstrated that N-CAM contains a heparin-binding domain (5), and this domain appears to be an integral component of the N-CAM-mediated cell adhesion mechanism. When immunopurified N-CAM is covalently coupled to glass surfaces, retinal cell attachment is inhibited by the C₁H₃ mAb and by heparin (5, 7). Likewise, the isolated heparin-binding domain promotes cell attachment (5) and the B₁A₃ mAb inhibits cell-cell adhesion (6). These data therefore imply that the binding of heparan sulfate to N-CAM is required for N-CAM-mediated cell interactions. Since previous studies had assigned a topographic location for the cell- or homophilic-binding domain (9), we were interested in determining the topographic location of the heparin-binding domain. This was of particular interest since the

binding of heparan sulfate to N-CAM induces a conformational change in the N-CAM protein (7). A similar conformational change has been described for fibronectin, and this leads to an increased affinity of fibronectin for other extracellular matrix components and for the cell surface (16).

Our initial experiments suggested that the heparin-binding domain of N-CAM was identical to Fr1, which was previously reported to be the cell-binding domain (9). After amino-terminal amino acid sequencing of the isolated heparin-binding domain, it could be concluded that the heparin-binding domain was also localized in the amino-terminal region of the N-CAM molecule. These results raise an important question: is the previously identified cell-binding domain in fact the heparin-binding domain, or are both localized to the amino-terminal region of the protein? As shown in Fig. 4 *a*, we constructed a linear model for the structure of the N-CAM molecule that is based on the conclusion that the cell-binding region described by Cunningham et al. (9) is the heparin-binding domain. In this model we aligned the heparin-binding domain in the amino-terminal region, and the cell-binding domain in a more internal position (>65,000-D from the amino terminus). The rationale for this model is that the C₁H₃ mAb inhibits N-CAM-mediated cell-cell adhesion (6) and binds to a polypeptide fragment that is distinct from Fr1 (Fig. 1, lane *c* and reference 5). These data would therefore suggest that the cell-binding and heparin-binding domains are located on different polypeptide fragments. However, at this time, the cell-binding region cannot be defined unequivocally because although the C₁H₃ mAb epitope is not a component of Fr1, it is unclear what region of N-CAM will contain this epitope. However, it is clear that the C₁H₃ epitope must be at least 40,000-D from the heparin-binding fragment. Thus, it is possible that the C₁H₃ epitope is located at the cleavage site for Fr1, if alternative cleavage of N-CAM occurs during proteolysis. In this case, any cleavage generating Fr1 would destroy the C₁H₃ epitope, and alternative cleavage sites would give rise to the fragments that the C₁H₃ mAb does recognize (5). Therefore, it is possible that the C₁H₃ mAb epitope is along the region of the N-CAM molecule extending from the cleavage site of the Fr1 fragment to the carbohydrate-containing region, although this remains to be determined.

It should be noted that the proposal that the cell-binding domain (which we are assuming is localized in a region that the C₁H₃ mAb binds) is located more internally than Fr1 depends upon several assumptions. The first is that the C₁H₃ mAb binds to a region of the N-CAM molecule that is involved in homophilic binding. The second assumption is that the C₁H₃ mAb does not inhibit cell-cell adhesion by a nonspecific mechanism (i.e., steric hindrance). The latter seems unlikely since the C₁H₃ epitope is separated from the B₁A₃ epitope by a minimum of 40,000 D on the linear map of N-CAM. In addition, while B₁A₃ blocks the binding of heparin sulfate to N-CAM, C₁H₃ does not show this effect (7), hence steric blockage of the heparin binding site by C₁H₃ seems unlikely. However, until further experiments are conducted, we have constructed two linear models to describe the relationship between N-CAM structure and function (Fig. 4 *a* and *b*). The second model, depicted in Fig. 4 *b*, is based on the hypothesis that both the cell- and heparin-binding domains are components of Fr1. Since the cell-binding domain was identified as a 65,000-D polypeptide

fragment (9), and the heparin-binding domain as a 25,000-D fragment, it is possible that the cell-binding domain is localized at least 25,000 D from the amino terminus (Fig. 4 b). If this is the case, then it could be proposed that after heparan sulfate (contained on a heparan sulfate proteoglycan) binding to N-CAM, the conformational change in N-CAM could modulate the binding of cells to the cell-binding domain, which is in close proximity to the heparin-binding domain. This model could therefore account for the experimental results of Cunningham et al. (9) and of this study. However, because the C₁H₃ mAb is not a component of Fr1, in this model the C₁H₃ mAb would be expected to inhibit cell adhesion nonspecifically, since the cell-binding domain is not associated with the C₁H₃ epitope. At this time we favor the proposal (Fig. 4 a) that the cell- and heparin-binding domains reside on distinct polypeptide fragments and that the previously described cell-binding domain is the heparin-binding domain. Additional support for this hypothesis could be obtained by the isolation of a polypeptide fragment, distinct from the heparin-binding domain, that can promote (or inhibit, depending on the assay) neural cell attachment. It is also noteworthy that other mAb's that recognize N-CAM and inhibit cell-cell adhesion have now been shown to react with the 25,000-D heparin-binding domain (Frelinger, L., and U. Rutishauser, personal communication). This discussion assumes that only two sites on N-CAM are responsible for its adhesion function. Clearly other sites, possibly overlapping, could be required for this function and are not identified by these antibodies.

Because the studies of Cunningham et al. (9) demonstrated that the cell-binding domain is localized to the amino-terminal region of N-CAM, we have also considered a third possibility to reconcile the results of their study and the present work. It is interesting to speculate that the cell- (homophilic) and heparin-binding domains are identical, and that the heparin-binding domain is responsible for homophilic binding. In this mechanism, the heparin-binding domain would be binding to a region of N-CAM that is similar in structure to the carbohydrate moiety of heparan sulfate proteoglycan. For example, previous studies have described the presence of HNK-1/L2 carbohydrate epitope on N-CAM, and this carbohydrate epitope is proposed to be involved in neuronal cell interactions (19). The precise structure of the HNK-1/L2 epitope on N-CAM is unknown, and it is unclear whether this carbohydrate epitope is an *O*- or *N*-linked moiety. However, this carbohydrate structure appears to be a 3-sulfated glucuronyl carbohydrate chain (also found in glycolipids in the nervous system; reference 2), and it is interesting to speculate that it may be able to interact with the heparin-binding domain of N-CAM.

We have also demonstrated in this study that the heparin-binding domain is conserved among N-CAMs from a variety of other species. The 25,000-D fragment could be derived from rat N-CAM, and the B₁A₃ mAb could immunopurify small amounts of N-CAM from a mouse muscle cell line. An interesting result of the muscle experiment is that greater amounts of N-CAM appear to be secreted from BC₃H1 cells into the conditioned medium when compared with neural cells. Since these cells produce adherons that promote cell-substratum attachment (26), it is possible that N-CAM is involved in cell attachment to these adherons; however, adherons from these cells also contain fibronectin and other

known matrix molecules (26). The demonstration that the B₁A₃ mAb reacts with N-CAM from other species therefore supports the data of Rougon and Marshak (22), which showed that the amino-terminal domain of N-CAM is a conserved structure. The fact that the heparin-binding domain is also exposed on the cell surface, which is a prerequisite for interaction with neighboring cells, is consistent with their results.

In conclusion, in these studies we have described the topographic location of the heparin-binding domain and a cellular-binding domain from N-CAM, and have shown that the heparin-binding domain is a conserved structure localized in the amino-terminal region of the N-CAM molecule.

The authors would like to thank Dr. Gregory Grant, and Mark Frazier and Mike Burg (Washington University School of Medicine) for their expert assistance in the amino acid sequence analysis of N-CAM.

This work was supported by grant GM 18405 from the National Institutes of Health.

Received for publication 5 June 1986.

References

1. Aebbersold, R. H., D. B. Teplow, L. E. Hood, and S. B. H. Kent. 1986. Electrobinding onto activated glass. High efficiency preparation of proteins from analytical sodium dodecyl sulfate-polyacrylamide gels for direct sequence analysis. *J. Biol. Chem.* 261:4229-4238.
2. Chou, D. K. H., G. A. Schwarting, and F. B. Jungalwala. 1986. Sulfated glucuronyl glycolipids in the nervous system. *Trans. Am. Soc. Neurochem.* 17:146.
3. Cole, G. J., and L. Glaser. 1984. Identification of novel neural- and neural retina-specific antigens with a monoclonal antibody. *Proc. Natl. Acad. Sci. USA.* 81:2260-2264.
4. Cole, G. J., and L. Glaser. 1984. Cell-substratum adhesion in embryonic chick central nervous system is mediated by a 170,000-mol-wt neural-specific polypeptide. *J. Cell Biol.* 99:1605-1612.
5. Cole, G. J., and L. Glaser. 1986. A heparin-binding domain from N-CAM is involved in neural cell-substratum adhesion. *J. Cell Biol.* 102:403-412.
6. Cole, G. J., A. Loewy, and L. Glaser. 1986. Neuronal cell-cell adhesion depends on interactions of N-CAM with heparin-like molecules. *Nature (Lond.)* 320:445-447.
7. Cole, G. J., D. Schubert, and L. Glaser. 1985. Cell-substratum adhesion in chick neural retina depends upon protein-heparan sulfate interactions. *J. Cell Biol.* 100:1192-1199.
8. Covault, J., J. P. Merlie, C. Goridis, and J. R. Sanes. 1986. Molecular forms of N-CAM and its RNA in developing and denervated skeletal muscle. *J. Cell Biol.* 102:731-739.
9. Cunningham, B. A., S. Hoffman, U. Rutishauser, J. J. Hemperly, and G. M. Edelman. 1983. Molecular topography of the neural cell adhesion molecule N-CAM: surface orientation and location of sialic acid-rich and binding regions. *Proc. Natl. Acad. Sci. USA.* 80:3116-3120.
10. Edelman, G. M. 1983. Cell adhesion molecules. *Science (Wash. D. C.)* 219:450-457.
11. Grumet, M., S. Hoffman, and G. M. Edelman. 1984. Two antigenically related neuronal cell adhesion molecules of different specificities mediate neuron-neuron and neuron-glia adhesion. *Proc. Natl. Acad. Sci. USA.* 81:267-271.
12. Grumet, M., U. Rutishauser, and G. M. Edelman. 1982. Neural cell adhesion molecules is on embryonic muscle cells and mediates adhesion to nerve cells in vitro. *Nature (Lond.)* 295:693-695.
13. Hirn, M., M. S. Ghandour, H. Deagostini-Bazin, and C. Goridis. 1983. Molecular heterogeneity and structural evolution during cerebellar ontogeny detected by monoclonal antibody of the mouse cell surface antigen BSP-2. *Brain Res.* 265:87-100.
14. Hoffman, S., B. C. Sorkin, P. C. White, R. Brackenbury, R. Mailhammer, U. Rutishauser, B. A. Cunningham, and G. M. Edelman. 1982. Chemical characterization of a neural cell adhesion molecule purified from embryonic brain membrane. *J. Biol. Chem.* 257:7720-7729.
15. Hunkapiller, M. W., E. Lujan, F. Ostrander, and L. E. Hood. 1983. Isolation of microgram quantities of proteins from polyacrylamide gels for amino acid sequence analysis. *Methods Enzymol.* 91:227-236.
16. Johansson, S., and M. Hook. 1984. Substrate adhesion of rat hepatocytes: on the mechanism of attachment to fibronectin. *J. Cell Biol.* 98:810-817.
17. Jorgensen, O. S., A. Delouee, J. P. Theiry, and G. M. Edelman. 1980. The nervous system specific protein D2 is involved in adhesion among neurites from cultured rat ganglia. *FEBS (Fed. Eur. Biochem. Soc.) Lett.* 111:39-42.
18. Keilhauer, G., A. Faissner, and M. Schachner. 1985. Differential inhibi-

tion of neurone-neurone, neurone-astrocyte and astrocyte-astrocyte adhesion by L1, L2 and N-CAM antibodies. *Nature (Lond.)*. 316:728-730.

19. Kruse, J., R. Mailhammer, H. Wernecke, A. Faissner, I. Sommer, C. Goridis, and M. Schachner. 1984. Neural cell adhesion molecules and myelin-associated glycoprotein share a carbohydrate moiety recognized by monoclonal antibodies L2 and HNK-1. *Nature (Lond.)*. 311:153-155.

20. Olson, E. O., K. L. Caldwell, J. I. Gordon, and L. Glaser. 1983. Regulation of creatine phosphokinase expression during differentiation of BC₃H1 cells. *J. Biol. Chem.* 258:2644-2652.

21. Rathjen, G., and M. Schachner. 1984. Immunocytological and biochemical characterization of a new neuronal cell surface component (L1 antigen) which is involved in cell adhesion. *EMBO (Eur. Mol. Biol. Organ.) J.* 3:1-10.

22. Rougon, G., and D. R. Marshak. 1986. Structural and immunological characterization of the amino-terminal domain of mammalian neural cell adhesion molecules. *J. Biol. Chem.* 261:3396-3401.

23. Rutishauser, U. 1984. Developmental biology of a neural cell adhesion molecule. *Nature (Lond.)*. 310:549-554.

24. Rutishauser, U., and G. M. Edelman. 1980. Effects of fasciculation on the outgrowth of neurites from spinal ganglia in culture. *J. Cell Biol.* 87:370-378.

25. Rutishauser, U., W. E. Gall, and G. M. Edelman. 1978. Adhesion

among neural cells of the chick embryo. IV. Relationship of the cell surface molecule CAM in the formation of neurite bundles in cultures of spinal ganglia. *J. Cell Biol.* 79:382-393.

26. Schubert, D., and M. LaCorbiere. 1982. The specificity of extracellular glycoprotein complexes in mediating cellular adhesion. *J. Neurosci.* 2:82-89.

27. Silver, J., and U. Rutishauser. 1984. Guidance of optic axons in vivo by a preformed adhesive pathway on neuroepithelial endfeet. *Dev. Biol.* 106:485-499.

28. Stallcup, W. B., and L. Beasely. 1985. Involvement of the nerve growth factor-inducible large external glycoprotein (NILE) in neurite fasciculation in primary cultures of rat brain. *Proc. Natl. Acad. Sci. USA.* 82:1276-1280.

29. Thiery, J. P., R. Brackenbury, U. Rutishauser, and G. M. Edelman. 1977. Adhesion among neural cells of the chick retina. II. Purification and characterization of cell adhesion molecule from neural retina. *J. Biol. Chem.* 252:6841-6845.

30. Vandekerckhove, J., J. Bauw, M. Puype, J. Van Damme, and M. Van Montagu. 1985. Protein-blotting on polybrene-coated glass fiber sheets. A basis for acid hydrolysis and gas-phase sequencing of picomole quantities of protein separated on sodium dodecyl sulfate/polyacrylamide gel. *Eur. J. Biochem.* 152:9-19.