



A hybrid decision-making framework to manage occupational stress in project-based organizations

Zeinab Sazvar¹ · Sina Nayeri¹ · Reza Mirbagheri² · Mehrab Tanhaeean¹ · Alireza Fallahpour³ · Kuan Yew Wong³

Accepted: 17 March 2022 / Published online: 17 May 2022

© The Author(s), under exclusive licence to Springer-Verlag GmbH Germany, part of Springer Nature 2022

Abstract

According to recent studies in the field of human resource management (HRM), especially in project-based organizations (PBOs), stress is recognized as a factor that has a paramount significance on the performance of staff. Previous studies in organizational stress management have mainly focused on identifying job stressors and their effects on organizations. Contrary to the previous studies, this paper aims to propose a comprehensive decision-support system that includes identifying stressors, assessing organizational stress levels, and providing solutions to improve the performance of the organization. A questionnaire is designed and distributed among 170 senior managers of a major project-based organization in the field of the energy industry in Iran to determine organizational stressors. Based on the questionnaire results and considering the best worst method (BWM) as an approach to determine the weighting vector, the importance degree of each stressor is calculated. In the next stage, a decision-support model is developed to assess the stress level of a PBO through fuzzy inference systems (FIS). Some main advantages of the proposed hybrid decision-support model include (i) achieving high-reliable results by not-so-time-consuming computational volume and (ii) maintaining flexibility in adding new criteria to assess the occupational stress levels in PBOs. Based on the obtained results, six organizational stressors, including job incongruity, poor organizational structure, poor project environment, work overload, poor job promotion, and type A behavior, are identified. It is also found that the level of organizational stress is not ideal. Finally, some main recommendations are proposed to manage occupational stresses at the optimum level in the considered sector.

Keywords Occupational stress · Best worst method · Project-based organization · Fuzzy inference system

✉ Zeinab Sazvar
sazvar@ut.ac.ir

Sina Nayeri
sina.nayeri@ut.ac.ir

Reza Mirbagheri
Rezamirbagheri@ut.ac.ir

Mehrab Tanhaeean
Mehrabtanhaeean@ut.ac.ir

Alireza Fallahpour
fallahpour.a@utm.my

Kuan Yew Wong
wongky@mail.fkm.utm.my

¹ School of Industrial Engineering, College of Engineering, University of Tehran, Tehran, Iran

² Department of Management, Faculty of Management, University of Tehran, Tehran, Iran

³ School of Mechanical Engineering, Universiti Teknologi Malaysia, 81310 Skudai, Malaysia

1 Introduction

Nowadays, life is crawling with stressful situations that adversely affect social and economic welfare and life satisfaction (Di Noia et al. 2020; Wagman et al. 2020). Stress can originate from either personal life or organizational issues like work conditions (M. Li et al. 2020a, b; N. Li et al. 2020a, b; Nunes et al. 2018). In this regard, organizations and specifically their human resource (HR) departments are trying to pursue policies designed to mitigate the presence of destructive stress, which is technically called distress.

Regarding job stress, neither very low levels nor very excessive levels are desirable since both cases, in turn, reduce the motivation and performance level of the staff. According to Fig. 1, organizational stress must be kept balanced at an intermediate level to maintain the

performance level of the staff at the desired level. Failure to maintain this intermediate value may lead to absenteeism, low productivity and motivation, drug abuse, marital problems, or even suicide (Aruna 2020; Milner et al. 2018; Verma 1996). One of the most dangerous results of a stressful workplace situation is a psychological state called burnout, which causes emotional exhaustion, routineness, and depersonalization. Similar symptoms may be seen in people with very low levels of job stress, which is called rust-out.

Stress is simply defined as a response, and the factors that trigger this response are called stressors. Project environments are inherently more exposed to the high level of occupational stress due to constraints on time, cost, human, and other resources (Aitken & Crawford 2007). Project managers, who are the most influential people in the project success, are continually struggling with many stressors such as work overload, conflicts or ambiguity in the roles, accountability to risks, and uncertainties. The stressors mentioned above are intensified in many cases of project-based organizations (PBOs) whose turnover is based on projects, and also they usually have a matrix organizational structure. Due to the high level of job stress in these cases, project managers are prone to burnout and even physical diseases such as hypertension or diabetes. Therefore, one of the main challenges of chief executives and HR managers in PBOs is to answer the following questions: (i) what are the major stressors that negatively impact the performance of the projects or organizations? (ii) what are the high-priority stressors? (iii) how can the level of occupational stress be assessed in an organization? (iv) is the employees' level of job stress desirable enough? (v) if not, what corrective actions should be taken?

To determine right answers to the above questions, decision-making models provide useful tools to identify effective organizational stressors, as well as the level of occupational stress. Nowadays, several decision-making approaches (e.g., DEMATEL, AHP, artificial neural

network, and support vector machine) exist, which are widely used in the decision-making processes for various fields (Akram, et al. 2021a, b, c; Akram et al. 2021; Akram, et al. 2021a, b, c; Altan & Karasu 2019; Aslan et al. 2017; SUNAY et al. 2020). Answering the above questions has a profound effect on the organization's planning in terms of workload balancing, the proportion of responsibilities and competencies, and the determination of welfare programs. While there is a broad range of studies dedicated to stress management, to the best of our knowledge, the problem of managing occupational stresses in PBOs is rare in the existing literature. Moreover, few studies have assessed the level of organizational stress by exploiting organizational stressors and proposing solutions, afterward. This paper aims to develop a hybridized decision-making framework under a fuzzy environment by integrating two decision-making models for assessing and managing occupational stress in a real PBO. In this respect, an integrated BWM-FIS model, welcomed by HR managers and chief executive officers (CEOs) of the PBO under study, is proposed that has several advantages such as:

- i) While maintaining simplicity and comprehensibility, the practitioners can assess the level of organizational stress quantitatively. This issue is highly significant for HR practitioners and project managers, especially after COVID-19 and the prevalence of teleworking.
- ii) It yields highly reliable results, approved by experts and statistical indicators, with an acceptable computing burden. Although the BWM model is very accurate and easy to learn for weighting, not many pairwise comparisons are required for computing the weights (for k decision-makers and n indicators, the AHP method needs $k \times \frac{n(n-1)}{2}$ pairwise comparisons, while the BWM requires $k \times (2n - 3)$).
- iii) Besides applying BWM, the FIS method, as a fuzzy logic-based decision-making model, is a suitable technique to solve the problem of ambiguity for data collection in the real world (Amindoust & Saghafinia 2017). This way, FIS is applied to assess the level of organizational stresses quantitatively. It is flexible to add new criteria (stressor) for organizational stress evaluation.

To sum up, there are three main purposes in this investigation that differentiate it from other research in the literature. The first purpose is to develop an engineering framework to identify PBOs' most effective stressors (criteria) and determine their importance degree (weights). The second purpose is to propose a decision-support system to assess the level of organizational stress. To the best of our knowledge, this paper is among the first studies on

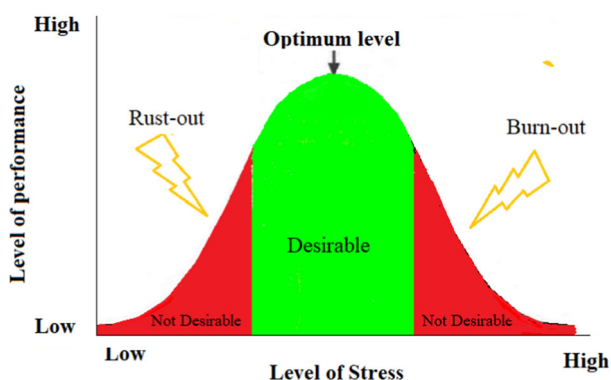

Fig. 1 The relationship between organizational stress and personnel performance levels (Verma 1996)

stress management that measures the level of organizational stress and determines whether it is desirable. The third purpose of the paper is to propose a list of suitable organizational solutions for situations in which the level of job stress is not favorable.

The rest of the paper is structured as follows: Sect. 2 is dedicated to introducing related studies in occupational stress. The research framework is discussed in Sect. 3. The proposed framework and sensitivity analysis results are presented in Sects. 4 and 5, respectively. Section 6 provides some managerial discussion, and finally, Sect. 7 discusses the conclusion and proposes some suggestions for further research.

2 Literature review

The constraints of time limitation, changing priorities, etc., are intrinsic to projects; hence, the projects are naturally subject to a high level of stress (Ullah et al. 2018). According to (Gmelch 1977) and (Leung et al. 2005), the stressors of project managers can be classified into four categories: task stressors, organizational stressors, personal stressors, and physical stressors.

Task stressors refer to work overload, role conflict, and role ambiguity, which are experienced by project managers (PMs) all the time along with their tasks. The intensive environment around the PMs will raise the workload and work pressure due to their permanent need for learning new project-related skills and variously required competencies. Role conflict occurs when different incompatible expectations are asked from an employee that interferes with other expectations (Biddle 1986). Role ambiguity occurs when there is no clarity about the expectations of the work and employees are uncertain about everyday tasks (Beehr 2014; Katz & Kahn 1978). Numerous studies indicate that work overload, role conflict, and role ambiguity lead to stressful situations (Eatough et al. 2011; Lambert et al. 2018).

Organizational stressors originate from the organizational environment, such as bureaucracy, high level of formalities, non-participation in the decision-making process, and job insecurity. An organizational structure, along with an overwhelming number of rules, bureaucratic conditions and hierarchies, bring upon conflict and unmet expectations, as well as job stress (Lait & Wallace 2002). A low degree of participation in the decision-making process can also lead to stressful situations (Elovainio et al. 2002). Job insecurity, which can be defined as a perception of a potential threat to continuity in the current job of employees (Heaney et al. 1994), also has a negative effect on employees' well-being and, therefore, creates distress (Witte 1999).

Personal stressors include Type A behavior and the degree of willingness to cooperate in the workplace. Type A behavior refers to those people who are aggressive, time-driven, and ambitious (Frankenhaeuser 1986). People with this type of personality are more liable to burnout and work overload (Hallberg et al. 2007; Sadeghi & Garosi 2017). Lack of cooperation between project managers and their subordinates can also lead to low job satisfaction and hence, a high perception of stress.

Physical stressors include poor work/home environments. Poor work environment refers to situations with inappropriate temperature, insufficient lighting, lack of privacy, noise, congestion in the office, etc., that can create stressful situations (McDonald & Ronayne 1989; Taap Manshor et al. 2003). Poor home environment also plays a pivotal role in causing stress (Leung et al. 2005).

2.1 Classification of the related research works

Regarding Table 1, some researchers have identified stressors associated with a particular job (construction estimators (Leung et al. 2005), coach divers (Liu et al. 2012), construction project consultants (Bowen et al. 2014), academic staff (Jannoo et al. 2015), healthcare professionals (Amole et al. 2018; Rajabi et al. 2018), farmers (Jahangiri et al. 2020), and firefighters (Rajabi et al. 2020), etc.

In addition to identifying stressors, some researchers sought the relationship between job stress and other job factors such as burnout (Enshassi et al. 2015; Senaratne & Rasagopalasingam 2016), job satisfaction (Calitz et al. 2014), turnover (Calitz et al. 2014; Liu et al. 2020), organizational commitment (Siu 2002), well-being (Siu 2002; MacIntyre et al. 2020), organizational change (Chauvin et al. 2014), person-job fit (Deniz et al. 2015), interpersonal and organizational performance (Senaratne & Rasagopalasingam 2016), etc.

From the perspective of research methodology, most articles have used statistical tools such as regression (Siu 2002; Bowen et al. 2014), Pearson correlation analysis (Enshassi et al. 2015; Senaratne & Rasagopalasingam 2016), ANOVO test (MacIntyre et al. 2020), or other statistical hypothesis tests (Deniz et al. 2015) to analyze job stressors and their effects on organizations.

As Table 1 indicates, some recent studies applied Multi-Criteria Decision-Making (MCDM) techniques such as AHP (Amole et al. 2018; Rajabi et al. 2018), DEMATEL (Liu et al. 2012), VIKOR (Liu et al. 2020), and Delphi (Jahangiri et al. 2020; Rajabi et al. 2020) to prioritize job stressors in industries.

Table 1 The main research developed in the subject of the current study

Research work	Correlation between the concept of occupational stress and organizational issues	Stressors	Methodology	Participants	Organizational stress assessment
Siu (2002)	Organizational Commitment, well-being	Job intrinsic, Role, Relationships, Career and achievement, Organizational structure, climate, and Home/work interface factors	Statistical analysis	Blue- and White-Collar Workers	×
Leung et al., (2005)		Personal, Interpersonal, Task and Physical factors	Statistical analysis	Construction estimators	×
Liu et al., (2012)		Job intrinsic, Socioeconomic, and Relationship factors	Fuzzy DEMATEL	Coach divers	×
Bachkirova (2012a)	Self-image and Identification with an organization		Qualitative approach (Quasi-judicial approach)	University lecturer	×
Bowen et al., (2014)		Job demand, Job control and Job support factors	Statistical analysis	Construction project consultants	×
Calitz et al., (2014)	Burnout, Job satisfaction, Work engagement, and Turnover		Statistical analysis	Social workers	×
Chauvin et al., (2014)	Organizational change	Psychological demands, Decision latitude, Supervisor support, Co-worker support, and Organizational difficulties	Statistical analysis	Employees from the University of Strasbourg	×
Deniz et al., (2015)	Person-job fit, Person organization fit	Work overload, Control, and Social support	Statistical analysis	Employees of various sectors	×
Enshassi et al., (2015)	Burnout and Safety performance	Organizational, Task, Personnel, and Work environment factors	Statistical analysis	Construction professionals	×
Enshassi & Al Swaity, (2015)		Task, Personal, Physical, and Organizational factors	Statistical analysis	Construction Professionals	×
Jannoo et al., (2015)		Job pressure, and Lack of organizational support	Statistical analysis	Academic staff	×
Senaratne & Rasagopalasingam, (2016)	Burnout, Interpersonal and organizational performance	Organizational, Physical, Task and Personal factors	Statistical analysis	Construction project managers	×
Amole et al., (2018)		Demand, Control, Support factors, Relationship, and Role factors	AHP	Healthcare professionals	×
Rajabi et al., (2018)		Managerial, Personal, Interpersonal, Environmental and Patient care factors	Fuzzy AHP (FAHP)	Healthcare professionals	×
Jahangiri et al., (2020)		Economic, Environmental and climate, Social and job-related and Spatial factors	Fuzzy Delphi Method (FDM) Fuzzy AHP (FAHP)	Farmers	×
Liu et al., (2020)	Turnover, Physical and Psychological fatigue	Itinerary pressure, Job intrinsic and Personal factors	DEMATEL, ANP, VIKOR (DANP-V)	Coach drivers	×
MacIntyre et al., (2020)	Well-being, and Negative emotion	15 stressors during COVID-19	Statistical approach	Language teachers	×

Table 1 (continued)

Research work	Correlation between the concept of occupational stress and organizational issues	Stressors	Methodology	Participants	Organizational stress assessment
Rajabi et al.,(2020)		Managerial, Personal, Interpersonal, and Operational factors	Fuzzy Delphi Method (FDM) Fuzzy AHP (FAHP)	Firefighters	×
The current research		Task, Organizational, Personal, and Physical factors	BWM, FIS	Project managers	✓

3 Research gap analysis

Regarding Table 1 and through investigating a multitude of papers, it is revealed that despite the attempts made to manage occupational stress, developing a practical framework based on quantitative and controllable engineering approaches to managing occupational stresses in stressful project-based environments has less been dealt with. Seemingly, none of the previous studies have addressed the issue of assessing the stress level in an organization as well. However, stress management and assessment are completely interrelated.

This paper is among the first attempts to develop a decision-support system to assess the level of organizational stress and manage it through a hybrid BWM-FIS framework. Determining the level of organizational stress by applying fuzzy inference systems is one of the main contributions of the current research work.

In summary, the current interdisciplinary study starts to address the above research gap that lies at the intersection of three main organizational issues: Project Management (PM), Stress Management (SM), and Decision Support Systems (DSS). It is shown in Fig. 2 schematically.

Some main features that distinguish this paper from the existing research in the related literature are as follows:

- This is the first attempt to investigate stress management in project-based organizations by proposing a hybrid BWM-FIS decision support model, to the best of our knowledge.
- This study is among the first studies that address the vital issue of assessing and determining the level of stress in an organization. As previously mentioned, the stress level should be mediocre; hence, there should be an approach to assess stress level and determine whether it is at the favorable level or not. If not, what kind of corrective action should be taken? There seems to be little or no research evidence on the issue of assessing the stress level in an organization or team.
- The research perspective has been shifting from personal solutions to organizational solutions for managing occupational stress.
- This research has emphasized identifying stressors, measuring the level of organizational stress, and recommending corrective actions in a real project-based environment.

4 Methodology

In this paper, a questionnaire is designed as the first stage, and after analyzing the results, the most important stressors are identified. Afterward, the best worst method (BWM) is applied to calculate the weight of stressors. At the next stage, a DSS is designed to assess the level of organizational stress using the Fuzzy Inference System (FIS). Some main reasons to propose and apply the hybrid BWM-FIS framework are summarized as follows:

- i. Reducing the computing burden by applying the BWM. The best worst method is a multi-criteria decision-making methodology based on pairwise comparisons and mathematical modeling. In addition to the high-reliable outputs, this method has less computational volume than methods based only on pairwise comparisons (Rezaei et al. 2016).
- ii. Increasing the flexibility of the method to add new criteria to assess occupational stress levels by using the FIS.

In the last stage, by studying best practices and previous works in the subject area and analyzing the comments made by experts in the HR department, a set of corrective actions are proposed to deal properly with the stressors in the considered particular industry. Figure 3 indicates the proposed research framework schematically.

Fig. 2 The scope of the current study lies at the intersection of three main disciplines

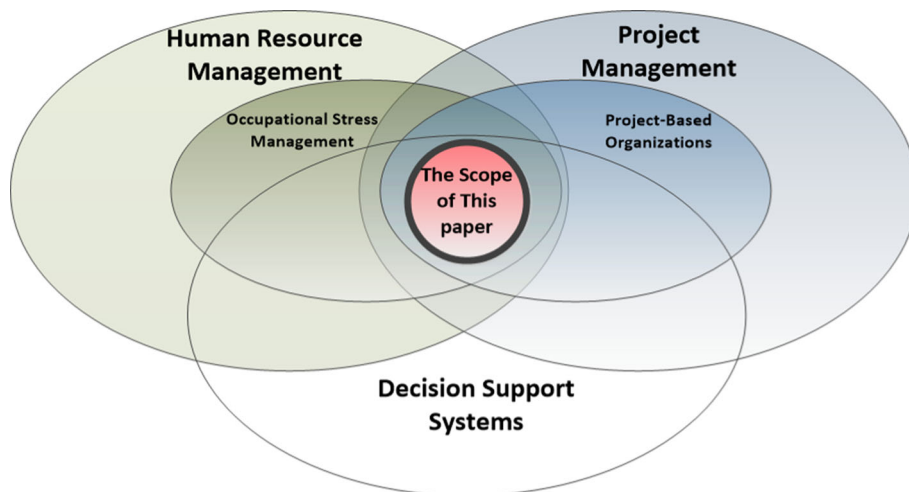

4.1 Identification of occupational stressors

In the first stage, the questionnaire is designed and distributed among experts to determine occupational stressors. After analyzing the questionnaire’s validity, the main occupational stressors are explored at this stage.

4.2 Determination of stressor’s weight

In this section, the weights of stressors are calculated, using the best worst method (BWM). BWM is one of the Multi-Attribute Decision-Making (MADM) methods widely used to obtain the weight of criteria in decision problems (Delice & Can 2020). This method compares all the criteria with the best and the worst criteria. This approach combines comparison-based methods with mathematical modeling to obtain optimal weights and consistency ratios. Based on Rezaei et al. (2016), the main advantages of BWM are as follows: (i) this method obtains highly reliable and consistent results because it applies a very structured pairwise comparison (ii) in this method, just two comparison vectors exist, which implies less effort for data gathering process (iii) the reliability of this method is high, because the collection and analysis of data for two vectors are more structured than a full matrix, and (iv) BWM can easily be integrated with other MADM methods. The BMW method follows the following steps (Rezaei 2015):

Step 1: Determine the Best and the Worst criteria

In the first step, the best and the worst criteria are determined by the decision-maker.

Step 2: Form the comparison vectors for the best and the worst criteria

Suppose that c_1, \dots, c_n are the selected criteria. The relative preference of criterion c_i toward criterion c_j is a_{ij} , which is determined by the help of Table 2.

If “ B ” and “ W ” indicate the best and the worst criteria respectively, best-to-others vector, A_B , and others-to-worst vector, A_W , are, respectively, as Eqs. 1 and 2:

$$A_B = (a_{B1}, a_{B2}, \dots, a_{Bn}) \tag{1}$$

$$A_W = (a_{1W}, a_{2W}, \dots, a_{nW})^T \tag{2}$$

It is obvious that $a_{BB} = a_{wW} = 1$.

Step 3: Determine the optimal weights

According to Rezaei (2015), the nonlinear optimization model expressed in Eq. 3 can determine the optimal value of weights i.e., w_j :

$$\min \max_j \left\{ \left| \frac{w_B}{w_j} - a_{Bj} \right|, \left| \frac{w_j}{w_w} - a_{jw} \right| \right\} \tag{3}$$

s.t.

$$\sum w_j = 1$$

$$w_j \geq 0, \quad \forall j$$

Equation 3 can be displayed as follows (Rezaei 2016):

$$\min \xi \tag{4}$$

s.t.

$$\left| \frac{w_B}{w_j} - a_{Bj} \right| \leq \xi \quad \forall j$$

$$\left| \frac{w_j}{w_w} - a_{jw} \right| \leq \xi \quad \forall j$$

$$\sum w_j = 1$$

$$w_j \geq 0, \quad \forall j$$

where ξ denotes consistency ratio. Whatever ξ is closer to zero, the comparison system is more consistent (Rezaei 2015, 2016).

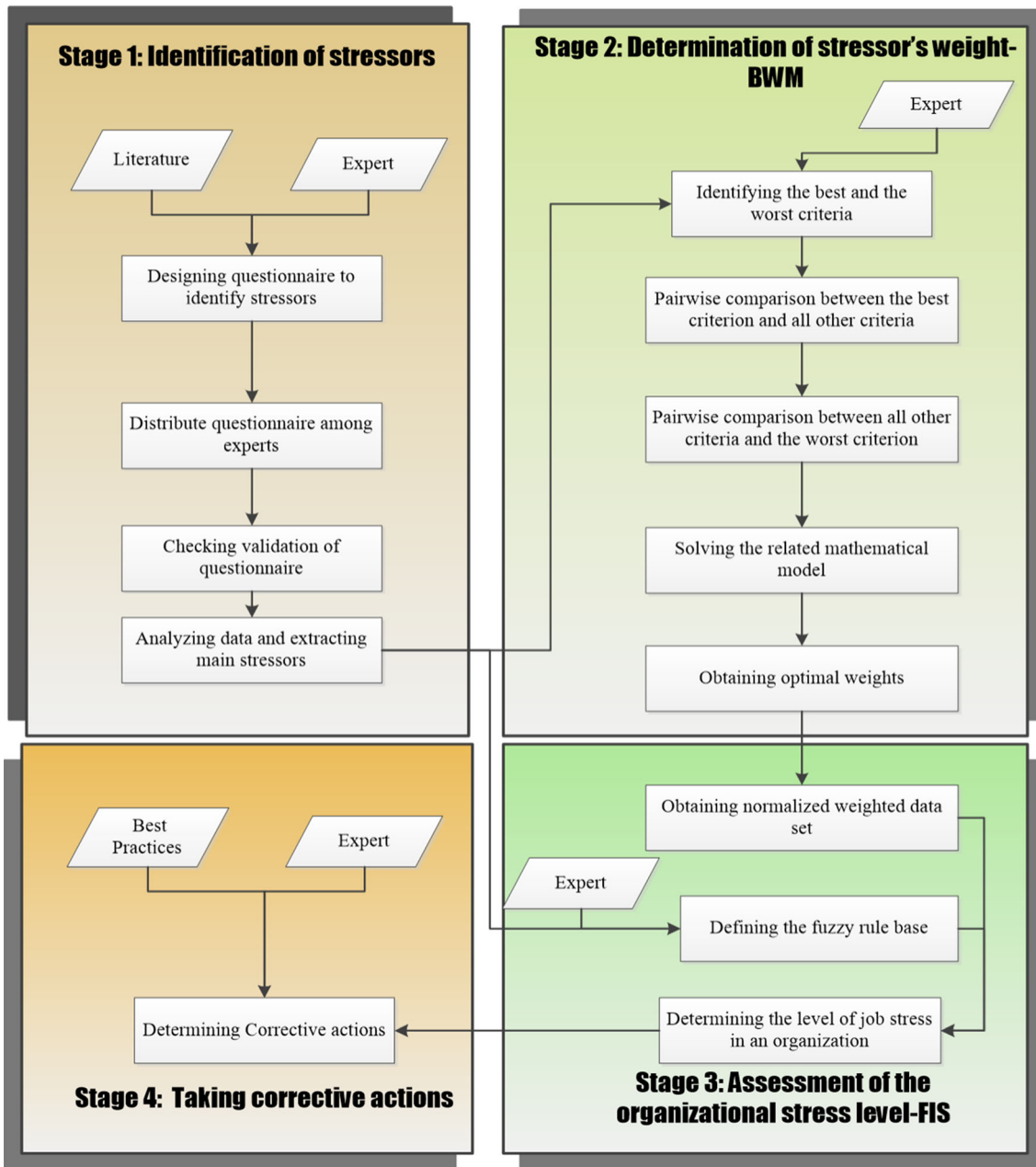

Fig. 3 The proposed BWM-FIS framework

Table 2 Transformation table for linguistic variables

Linguistic term	Value
Extremely preferred	9
Very strongly preferred	7
Strongly preferred	5
Moderately preferred	3
Equally preferred	1

4.3 Assessment of the organizational stress level-fuzzy inference systems

After determining the main stressors, several fuzzy rules should be established based on the experts' opinions to implement the FIS (Sayeekumar et al. 2019). This way, M^C rules are required to define for C criteria and M member-

ship functions. To avoid rule explosion and define the rules more simply, FIS models are usually designed so that the maximum number of fuzzy inputs is equal to two elements (for more details please see Amindoust et al. 2012). To clarify this issue, we will give an example. Suppose that there are 4 criteria and 5 membership functions. By two following stages, the number of rules can be reduced from 625 to 25: i) after selecting two by two of input variables (criteria), determine output variables, ii) consider the outputs of the previous stage as inputs of the FIS and specify the final output.

By considering the approach of Amindoust et al., (2012) and the relation between the stress and the level of the performance (see Fig. 1), after negotiating with the experts of the case company, the fuzzy rule base (Table 3) is developed. In this regard, the following fuzzy functions are applied for input elements:

- *Very Low (VL)* = (1,2,3)
- *Low (L)* = (2,3,4)
- *Average (A)* = (3,4,5)
- *High (H)* = (4,5,6)
- *Very High (VH)* = (5,6,7)

Moreover, the following outputs (level of the stress) are considered in the proposed two-by-two FIS:

- *High Risk (HR)* = (1,2,3)
- *Dangerous (D)* = (2,3,4)
- *Moderate (M)* = (3,4,5)
- *Good (G)* = (4,5,6)
- *Very Good (VG)* = (5,6,7)

After collecting the linguistic data set, it will be converted to crisp values. For this purpose, the Graded Mean Integration (GMI) representation method (Eq. (5)) is applied. The GMI has already been employed in many previous fuzzy multi-criteria decision-making studies due to its simplicity and accuracy (Chen & Hsieh 1999; Aria et al. 2020; and Alamroshan et al. 2021).

$$\vartheta(\tilde{A}) = \frac{(l + 4m + u)}{6} \tag{5}$$

Table 3 The fuzzy rule base

Second input	First input				
	VL	L	A	H	VH
VL	HR	HR	M	HR	HR
L	HR	D	G	D	HR
A	M	G	VG	G	M
H	HR	D	G	D	HR
VH	HR	HR	M	HR	HR

where \tilde{A} is a triangular fuzzy number (TFN) as (l, m, u) and $\vartheta(\tilde{A})$ shows the crisp value of \tilde{A} .

The weighted input data set is obtained by multiplying the derived weights (obtained by BWM) in the crisp input data set. Since the weights are less than one, the weighted values are poor for applying the FIS system and reporting reliable results. The weighted data set can be normalized by Eq. (6) to deal with this challenge.

$$NWD = \frac{WD * 100}{MPWD} \tag{6}$$

where NWD and WD are the normalized weighted and the weighted data set, respectively, and MPWD is the maximum value of WDs. Since $NWD \in [0, 100]$, it is required to define new rules. For this purpose, we define VL = (0, 20, 40); L = (20, 40, 60); A = (40, 60, 80); H = (60, 80, 100); VH = (80, 100, 100) and still consider the rules as Table 3.

Finally, it is noteworthy to say that when the number of experts is not limited to one, the aggregated value for each criterion can be measured as follows (Fallahpour et al. 2019):

$$l_j = \frac{\sum_{k=1}^d l_j^k}{d}, m_j = \frac{\sum_{k=1}^d m_j^k}{d}, u_j = \frac{\sum_{k=1}^d u_j^k}{d} \tag{7}$$

In Eq. 7, d denotes the number of experts and (l_j^k, m_j^k, u_j^k) shows the k th experts' thought on the value of j th criterion.

4.4 Taking corrective actions

According to the interpretation obtained from Stage 2 and through interviews with experts and studying best practices, organizational solutions for balancing the level of organizational stress are identified and suggested.

5 Implementation of the proposed BWM-FIS model

According to the literature review section (Leung et al. 2005) and by getting assistance from experts, a questionnaire is designed to determine the main stressors. This questionnaire is distributed among more than 170 experienced experts of an industrial major corporation's project management office (PMO). More than twenty years, this corporation has engaged in upstream energy projects utilizing modern management knowledge, tools, and techniques. The corporation also hires experienced project managers, specialists, and experts. The individuals in the considered statistical population already have at least a world-class certificate in project management like project management professional (PMP). After two attempts of

sending and receiving, 30 complete questionnaires were received. The results are indicated in Table 4.

5.1 Identification of stressors

According to Table 4 and the statistics obtained, among the nine stressors, six of them in the project-based organization studied affect the performance of human resources, especially project managers. These stressors are work overload, job incongruity, poor organizational structure, poor project environment, poor job promotion, and type A behavior.

5.2 Determining stressor’s weight

According to the previous section, the studied organization is involved with C_1 to C_6 which are the main stressors. Now, the identified stressors weight should be calculated to determine the impact of each stressor on the overall stress

of the organization. In this study, these weights are determined using BWM.

At the first step, the best and the worst criteria are determined according to a consensus among experts (a combination of three kinds of experts, introduced in Appendix, Table 13). This way, ‘Job incongruity’ (C_2) and ‘type A behavior’ (C_6) are defined as the best and the worst criteria, respectively. Subsequently, the comparisons between the best criterion with all the other criteria are made and the results are reported in Table 5. Similarly, Table 6 is provided for the worst criterion. Finally, the obtained weights for stressors are calculated and reported in Table 7 and Fig. 4.

5.3 Assessment of the organizational stress level-FIS

Three teams of experts opinions (see Appendix) on the level of each criterion are gathered and aggregated by

Table 4 Results of the questionnaire

Criterion index	Stressors	Questionnaire analyses, ✓ Active, × Inactive	Number of questions	Description of each criterion	Cronbach’s alpha	Number of respondent
C_1	Work overload	✓	4	Time pressure Intensive learning environment	0.994	30
C_2	Job incongruity	✓	3	Conflict Lack of clearness		
C_3	Poor organizational structure	✓	4	Bureaucratic environment Poor participation in decision-making		
C_4	Poor project environment	✓	5	Safety concerns Insufficient budget Scope creeping		
C_5	Poor job promotion	✓	3	Poor cultural environment Lack of promotion opportunities		
C_6	Type A behavior	✓	3	Time driven personality Lack of focus for a long time Strong desire for high quality		
C_7	Poor work environment	×	3	Noise, congestion, temperature		
C_8	Poor home environment	×	3	The incongruity between job and private life Dissatisfaction in the home environment		
C_9	Poor workgroup cooperation	×	3	Poor relationship with managers and peers Distrustful environment		

Table 5 Pairwise comparisons for the best criterion according to the experts' opinions

Expert	Best criterion	Criteria					
		C ₁	C ₂	C ₃	C ₄	C ₅	C ₆
1	Job incongruity	7	1	3	5	7	9
2	Job incongruity	6	1	3	7	6	9
3	Job incongruity	7	1	4	6	7	9

Table 6 Pairwise comparisons for the worst criterion according to the experts' opinions

Criteria	Expert		
	Type A behavior (worst criterion)		
	1	2	3
C ₁	5	6	5
C ₂	9	9	9
C ₃	7	5	6
C ₄	7	6	8
C ₅	3	2	4
C ₆	1	1	1

Eq. 7 to develop the FIS model based on the membership functions in determined in Sect. 3.3. After calculating crisp values (Eq. 5) and by applying Eq. 6, the normalized weighted crisp values are calculated as input variables for the FIS. The input values are reported in Table 8.

As explained earlier, the Amindoust et al. (2012) approach is taken into account to develop the proposed FIS model. This way, the proposed model is designed in three stages shown in Fig. 5.

The proposed FIS is coded in MATLAB R2016b. Figure 6 shows the rule viewer of the proposed FIS related to C₁ and C₂, as an instance. This figure shows that the two

Table 7 BWM weights for occupational stressors

Criteria	Expert			Average
	1	2	3	
C ₁	0.08637957	0.1012397	0.09551098	0.09437675
C ₂	0.4679519	0.4710744	0.4947469	0.4779244
C ₃	0.2015523	0.2024793	0.1671442	0.190391933
C ₄	0.1209314	0.08677686	0.1114295	0.106379253
C ₅	0.08637957	0.1012397	0.09551098	0.09437675
C ₆	0.03680521	0.03719008	0.03565743	0.036550907

left columns depict input variables, while the other is related to the output (FIS11). As well, 25 rules are defined by considering two input variables and five membership functions. The output of the proposed FIS related to C₁ and C₂ is reported in Fig. 7.

After completing the operations in all three stages, job stress in the organization is reported as 2.0. Consequently, the PBO is in a high-risk situation in terms of occupational stresses.

5.4 Taking corrective actions

In order to tackle severe stress problems, certain corrective actions and strategies are extracted through brainstorming in the presence of HR and PM managers. The proposed actions for both non-desirable situations, i.e., too high (Area C) and too low occupational stress level (Area A), are listed in Fig. 8.

The proposed solutions can be into three categories: long-term/strategic, mid-term, and short-term solutions. One benefit of this categorization is determining the solutions pursued based on available financial resources to have better results. Considering the categorization above, it can be inferred that job redesign and enhancing employees' participation are the strategic solutions. Mid-term solutions are the establishment of a counseling office, improvements in the physical work environment/conditions, specifying goals effectively, and improving interpersonal relations. Finally, workshop designing to deal with role clarity (especially for each project team), role analysis, and health and wellness programs can be seen as short-term solutions.

Moreover, when the level of stress in the organization is very low, job redesign, developing self-conducted teams, and encouraging supportive leadership style are considered strategic solutions, while using motivational techniques and designing competition programs for teams/projects are respectively mid-term and short-term actions.

6 Validation and sensitivity analysis

In this section, three validation methods are performed to show the robustness of the proposed hybrid BWM-FIS in assessing the occupational stress level in PBOs: 1) analyzing the consistency ratio of BWM, 2) comparing the performance of the applied decision-making approach with traditional ones, and 3) analyzing the obtained results of the proposed FIS by applying various defuzzification techniques such as COA (Center Of Area), MOM (Mean Of Maximum), BOA (Bisector Of Area), SOM (Smallest Of Maximum), and LOM (Largest Of Maximum) (Amin-doust & Saghafinia 2017).

Fig. 4 Stressor’s weights in the case organization

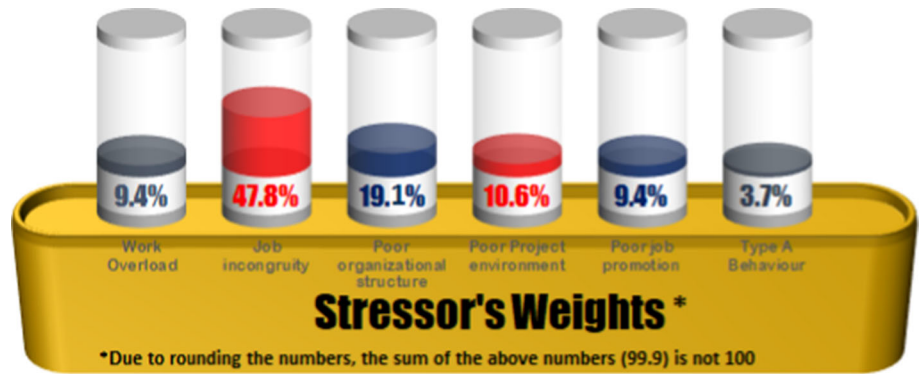

Table 8 The normalized weighted crisp values for measuring the level of stress using FIS

Criterion	C ₁	C ₂	C ₃	C ₄	C ₅	C ₆
Value	20.98	100	32.36	19.47	20.98	5.73

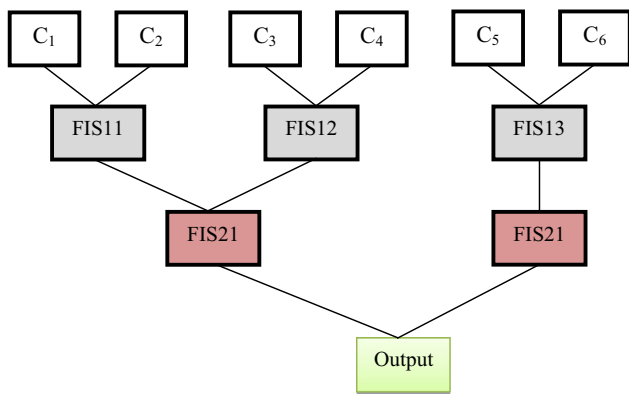

Fig. 5 The process of implementing FIS using the normalized weighted inputs

6.1 Analyzing the consistency index

Rezaei, (2015, 2016) stated that the consistency index must be close to zero for evaluating the robustness of the weights. It shows whether the opinion of the experts about the criteria is suitable or not. As it is seen, the average consistency index is 0.01 (0.009 for the first experts’ group, 0.011 for the second experts’ group, and 0.010 for the third experts’ group). It proves that the results related to the weights of the attributes are appropriate.

6.2 Comparison of the traditional and proposed methods

To show the validation and verification of the developed method, the BWM results are compared with those obtained by a traditional method, i.e., the AHP. As can be

seen in Table 9, the results of both methods are very close, which indicates the validity of the method applied. However, the consistency ratio (CR) of the BWM is lower than the AHP, which implies the high reliability of the BWM.

6.3 Applying different defuzzification methods

Changing the defuzzification method is an appropriate way to verify the robustness of a FIS-based model. For this purpose and by considering COA, BOA, MOM, SOM, and LOM methods (in place of GMI), the proposed model is run, and obtained results are reported in Table 10. Regarding this table, changing the defuzzification method does not affect the final result, and the level of occupational stress is still in the high-risk situation.

7 Discussion and managerial implications

According to the results obtained so far, it is found that the occupational stress level at the considered organization is high risk (see Tables 10 and 11). Therefore, the organization’s situation can be improved from ‘high risk’ to ‘good’ or ‘very good’ by taking some corrective actions listed in Fig. 8 for Area C.

Since financial and managerial resources are not so abundant these days, choosing suitable organizational solutions/corrective actions is of paramount importance for the organizations. Based on senior executives’ recommendations, effective attempts for implementing the following three solutions to cope with the stressful environment better for this real case are discussed below.

Job redesign: Based on the senior executives’ opinions, job redesign, as a long-term and strategic solution, has a high priority for implementation. Job redesign implies having sufficient challenges without being stuck in monotonous or overloaded situations. Rewards should also be based on employees’ skills.

Job enlargement and job enrichment are the two main approaches to implement job redesign. The first refers to

Fig. 6 Rule viewer of the proposed FIS11 associated with C_1 and C_2

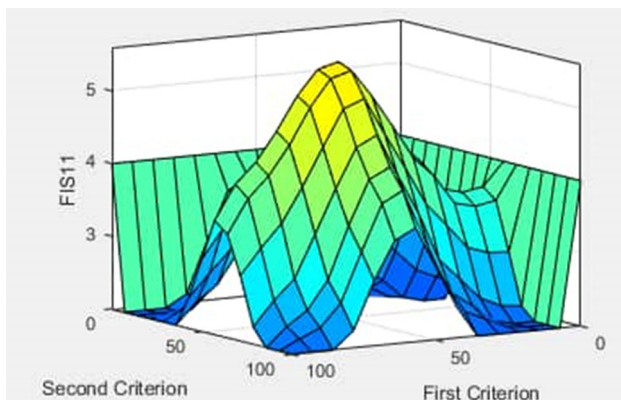
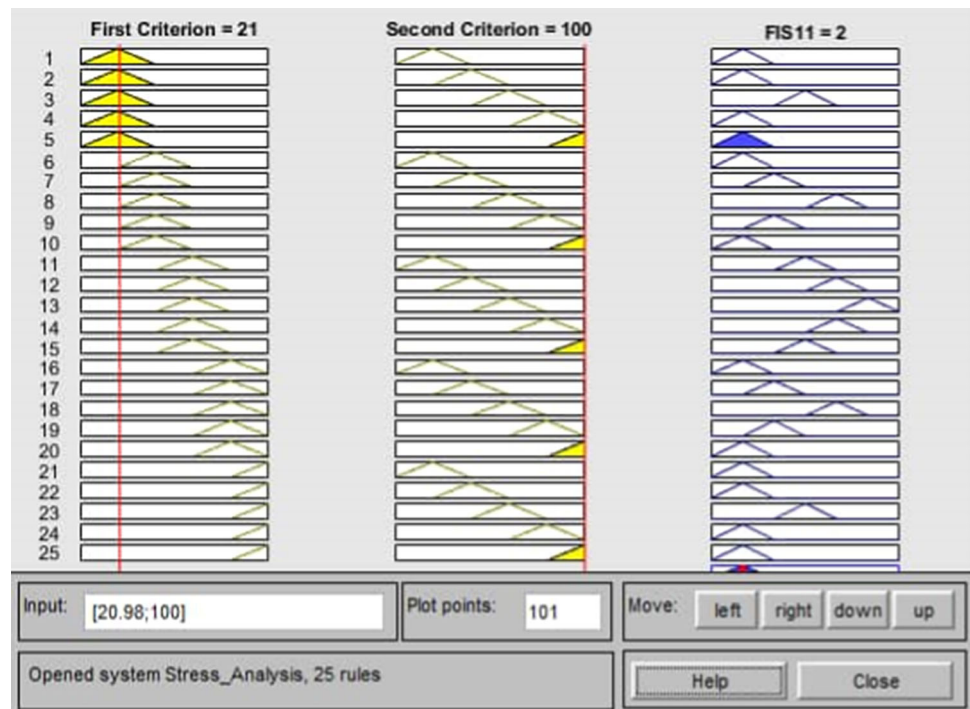

Fig. 7 The output of the FIS associated with C_1 and C_2

making the assigned tasks more diverse by defining new tasks with the same level of difficulty and responsibility compared to the previous tasks for employees. Contrary to the first approach, the second approach adds more complexity and responsibility to the existing tasks. It implies that employees are responsible for carrying out, organizing, and controlling their assigned tasks concurrently (Kopelman 1985).

Workshops dealing with role clarity and role analysis: as mentioned before, role ambiguity and role conflict are two major sources of stress, especially in PBOs with matrix organizational structure. Workshops designed to address these issues help employees have a solid understanding of their role, responsibility, and accountability, and reduce

role conflicts stemming from different incompatible interfering expectations (Verma 1996).

Establishing a counseling office: every person in an organization confronts two kinds of problems, person-related and organization-related problems. The counseling office addresses the person-related problems by directly meeting with the employees and playing a mediator role in balancing their lives. When it comes to the latter kind, the office distinguishes the role-related problems, such as role conflict and poor participation. It transfers these problems to an appropriate organizational level to cope with (Verma 1996).

It is noteworthy to say that these three solutions have a great impact on conflict resolution at the organizational level, interpersonal level, and personal level. This attests to the fact that conflict is a major source of stress for the oil and gas sector executive managers pointed out.

Based on the experts' opinion, "improvement of interpersonal behavior", which serves as an organizational solution, is of less importance in the organization under study. This happened due to the fact that the organizational atmosphere is favorable and interpersonal behavior is well established.

8 Conclusion

The current study has proposed a hybrid BWM-FIS framework to introduce a stress assessment model in project-based organizations. Although occupational stress

Fig. 8 Corrective action's portfolio

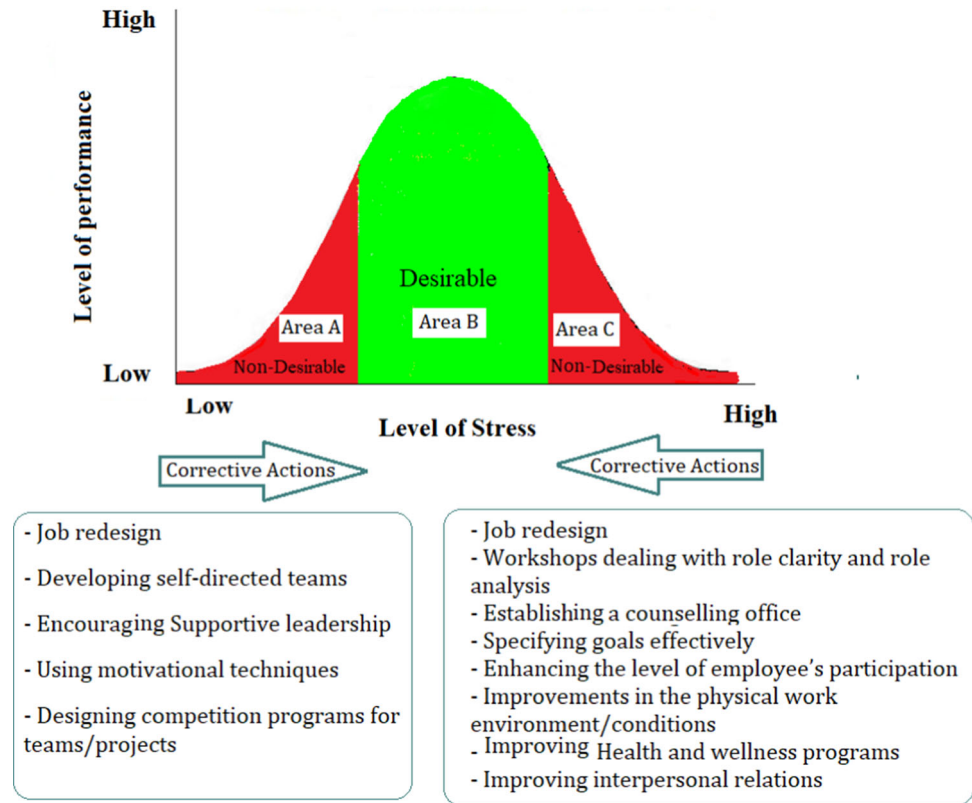

Table 9 Comparing the results of the BWM method with the AHP method

Indicator	Weight	
	AHP	BWM
C_1	0.09306516	0.09437675
C_2	0.48010063	0.4779244
C_3	0.19105637	0.190391933
C_4	0.107500129	0.106379253
C_5	0.092876321	0.09437675
C_6	0.038163157	0.036550907
CR	0.047	0.01

Table 10 Sensitivity analysis on the defuzzification methods

Method	MOM	LOM	SOM	COA	BOA	
OUTPUT	2	1.99	2.32	1.72	2	2.02

influences employees' performance directly, there is a lack of attention to developing decision-making frameworks for the research problem literally. This way, a questionnaire was designed to identify stressors in project-based organizations by doing a comprehensive literature review and

getting assistance from experts. Afterward, using BWM, the weights of the identified criteria were determined. Eventually, the stress level of the organization was assessed via proposing a FIS. To the best of our knowledge, this is the first attempt to measure occupational stress in organizations, especially PBOs. The BWM findings showed that job incongruity (C_2) with the weight of 0.4779 is the most important among the six main criteria. It is followed by C_3 , C_4 , C_5 , C_1 , and C_6 . Moreover, the results obtained from the FIS model showed that the stress level of the organization was at a high-risk level.

Later on, through conducting brainstorming sessions and interviews in the presence of executive managers, HR, and PM managers, three main corrective measures (job redesign, holding workshops to deal with role clarity and role analysis, establishing a counseling office) were selected to improve the stress level and, consequently, the performance level of employees, especially project managers, would heighten.

The obtained results can be applied for HR, PM, and DM practitioners. However, there are some research limitations. In this research, a multi-stage approach (Amin-doust et al. 2012) was applied to reduce the number of FIS input elements to two criteria. However, if more variables/criteria are considered as input simultaneously, the number of rules will increase significantly. Besides, the proposed hybrid decision-making framework was implemented in an

Iranian PBO. The stressors, solutions, and fuzzy rule base obtained cannot therefore be generalized to other geographical areas.

Instead of BWM method, other weighting techniques such as DEMATEL, ANP, and TOPSIS can be used in future studies. In this regard, taking appropriate approaches to consider the criteria interrelationships is fruitful. To select other decision-making methodologies for

determining weights and extending the current study, the researchers can see Pena et al. (2020).

Appendix

See Tables 11, 12 and 13 .

Table 11 The experts’ opinions about the criteria for measuring the level of job stress at the organization

	C1	C2	C3	C4	C5	C6
Expert 1	VH	H	A	H	VH	A
Expert 2	H	VH	A	H	H	A
Expert 3	VH	H	H	A	VH	A
Expert 1	(5,6,7)	(4,5,6)	(3,4,5)	(4,5,6)	(5,6,7)	(3,4,5)
Expert 2	(4,5,6)	(5,6,7)	(3,4,5)	(4,5,6)	(4,5,6)	(3,4,5)
Expert 3	(5,6,7)	(4,5,6)	(4,5,6)	(3,4,5)	(5,6,7)	(3,4,5)
Average	(4.67,5.67,6.67)	(4.33,5.33,6.33)	(3.33,4.33,5.33)	(3.67,4.67,5.67)	(4.67,5.67,6.67)	(3,4,5)
Crisp value	5.66	5.33	4.33	4.66	5.66	4
Derived weights × Crisp data	0.53	2.54	0.82	0.49	0.53	0.14
NWD	20.98	100	32.36	19.47	20.98	5.73

Table 12 The nomenclature

Notation	Definition
I	Index of criterion, $i \in I = \{1, \dots, n\}$
c_i	Criterion i , $i \in I$
a_{ij}	Relative preference of c_i to c_j , $i, j \in I$
B	The best criterion
W	The worst criterion
A_B	Best-to-others vector
A_W	Others-to-worst vector
W_B	Weight of B
W_W	Weight of W
W_i	Weight of c_i , $i \in I$
ξ	Consistency ratio
d	Number of experts
(l_j^k, m_j^k, u_j^k)	The k^{th} experts’ opinion on the value of criterion i , $i \in I$
$\tilde{A}_j = (l_j, m_j, u_j)$	Fuzzy value of criterion i , $i \in I$
NWD	The normalized weighted data set
WD	The weighted data set
MPWD	The maximum possible weighted data set
$\vartheta(\tilde{A})$	The crisp value of the TFN \tilde{A}

Table 13 Experts description

Experts	Description
Project managers	Project managers with the PMP certificate and at least seven years' work experience on the medium/large scale projects
HR managers	Human resource managers/consultants in the organization with more than 10-year work experience
Industrial/academic consultant	Representatives of consulting organizations that are in long-term cooperation with the company

Author contributions ZS: Methodology, modeling, data analysis, and writing—original draft preparation, supervision; SN: Material preparation, modeling, data analysis, and writing—original draft preparation; RM: Material preparation, data collection, modeling, and writing—original draft preparation; MT: Methodology, modeling, and visualization; AF: Methodology, modeling, and data analysis; KYW: Methodology, modeling, data analysis, and supervision.

Funding The authors declare that no funds, grants, or other support were received during the preparation of this manuscript.

Declarations

Conflict of interest The authors have no relevant financial or non-financial interests to disclose.

Data availability The data sets generated during the current study are not publicly available but are available from the corresponding author.

References

- Aitken A, Crawford L (2007) Coping with stress: Dispositional coping strategies of project managers. *Int J Project Manage* 25(7):666–673
- Akram M, Kahraman C, Zahid K (2021a) Extension of TOPSIS model to the decision-making under complex spherical fuzzy information. *Soft Comput* 25(16):10771–10795
- Akram M, Peng X, Sattar A (2021c) A new decision-making model using complex intuitionistic fuzzy Hamacher aggregation operators. *Soft Comput* 25(10):7059–7086
- Akram M, Naz S, Edalatpanah SA, Mehreen R (2021b) Group decision-making framework under linguistic q-rung orthopair fuzzy Einstein models. *Soft Comput* 25(15):10309–10334
- Alamroshan F, La'li M, Yahyaei M (2021) The green-agile supplier selection problem for the medical devices: a hybrid fuzzy decision-making approach. *Environ Sci Pollut Res* 29(5):6793–6811
- Altan A, Karasu S (2019) The effect of kernel values in support vector machine to forecasting performance of financial time series. *J Cognit Syst* 4(1):17–21
- Amindoust A, Saghafinia A (2017) Textile supplier selection in sustainable supply chain using a modular fuzzy inference system model. *J Text Inst* 108(7):1250–1258
- Amindoust A, Ahmed S, Saghafinia A, Bahreininejad A (2012) Sustainable supplier selection: a ranking model based on fuzzy inference system. *Appl Soft Comput* 12(6):1668–1677
- Amole BB, Adebisi SO, Dakare O (2018) Multi-criteria decision analysis of occupational stress among healthcare professionals in Nigeria. *Prog Health Sci* 8(1):113–125
- Aria S, Torabi SA, Nayeri S (2020) A hybrid fuzzy decision-making approach to select the best online-taxis business. *Adv Ind Eng* 54(2):99–120
- Aruna S (2020) Burn-out and stress percipience benefits of a stress management program by autogenic relaxation training for teachers: a pilot study. *Int J Res Pharm Sci* 11(1):480–490
- Aslan, O., Altan, A., & Hacıoglu, R. (2017). The control of blast furnace top gas pressure by using fuzzy PID. In: proceedings of the fifth international conference on advances in mechanical and robotics engineering–AMRE, pp. 22–26
- Bachkirova T (2012a) The role of the self and identification with an organisation as factors influencing work-related stress: implications for helping. *Couns Psychol Q* 25(1):49–62
- Beehr TA (2014) Psychological stress in the workplace (psychology revivals). Routledge
- Biddle BJ (1986) Recent developments in role theory. *Ann Rev Sociol* 12(1):67–92
- Bowen P, Edwards P, Lingard H, Cattell K (2014) Occupational stress and job demand, control and support factors among construction project consultants. *Int J Project Manage* 32(7):1273–1284
- Calitz T, Roux A, Strydom H (2014) Factors that affect social workers' job satisfaction, stress and burnout. *Soc Work* 50(2):153–169
- Chauvin B, Rohmer O, Spitzenstetter F, Raffin D, Schimchowitsch S, Louvet E (2014) Assessment of job stress factors in a context of organizational change. *Revue Européenne De Psychologie Appliquée/european Review of Applied Psychology* 64(6):299–306
- Chen, S. H., & Hsieh, C. H. (1999). Optimization of fuzzy simple inventory models. In: FUZZ-IEEE'99. 1999 IEEE international fuzzy systems. Conference proceedings (Cat. No. 99CH36315), vol. 1, pp. 240–244
- Delice EK, Can GF (2020) A new approach for ergonomic risk assessment integrating KEMIRA, best–worst and MCDM methods. *Soft Comput* 24(19):15093–15110
- Deniz N, Noyan A, Ertosun ÖG (2015) Linking person-job fit to job stress: the mediating effect of perceived person-organization fit. *Procedia Soc Behav Sci* 207:369–376
- Di Noia A, Martino A, Montanari P, Rizzi A (2020) Supervised machine learning techniques and genetic optimization for occupational diseases risk prediction. *Soft Comput* 24(6):4393–4406
- Eatough EM, Chang C-H, Miloslavic SA, Johnson RE (2011) Relationships of role stressors with organizational citizenship behavior: a meta-analysis. *J Appl Psychol* 96(3):619
- Elovainio M, Kivimauki M, Eccles M, Sinervo T (2002) Team climate and procedural justice as predictors of occupational strain 1. *J Appl Soc Psychol* 32(2):359–372
- Enshassi A, El-Rayyes Y, Alkilani S (2015) Job stress, job burnout and safety performance in the Palestinian construction industry. *J Financ Manag Prop Constr* 20(2):170–187
- Enshassi, A., & Al Swaity, E. (2015). Key stressors leading to construction professionals' stress in the Gaza strip, Palestine.

- Key Stressors Leading to Construction Professionals' Stress in the Gaza Strip, Palestine, 20(2)
- Fallahpour A, Wong KY, Rajoo S, Mardani A (2019) An integrated fuzzy carbon management-based model for suppliers' performance evaluation and selection in green supply chain management. *Int J Fuzzy Syst* 22(2):712–723
- Frankenhaeuser M (1986) A psychobiological framework for research on human stress and coping. In: Appley MH, Trumbull R (eds) *Dynamics of stress*. Springer, Berlin, pp 101–116
- Gmelch, W. H. (1977). *Beyond stress to effective management*. OSSC Bulletin Vol. 20, Nos. 9 and 10
- Hallberg UE, Johansson G, Schaufeli WB (2007) Type A behavior and work situation: associations with burnout and work engagement. *Scand J Psychol* 48(2):135–142
- Heaney CA, Israel BA, House JS (1994) Chronic job insecurity among automobile workers: effects on job satisfaction and health. *Soc Sci Med* 38(10):1431–1437
- Jahangiri M, Molaeifar H, Rajabi F, Banaee S (2020) Occupational stressors among farmers in Iran using fuzzy multiple criteria decision-making methods. *J Agromed* 25(1):28–37
- Jannoo Z, Yap BW, Haron H (2015) Evaluation of the job stress survey and its factor structure. *Qual Quant* 49(2):711–726
- Katz D, Kahn RL (1978) *The social psychology of organizations*, vol 2. Wiley, New York
- Kopelman RE (1985) Job redesign and productivity: a review of the evidence. *Natl Product Rev* 4(3):237–255
- Lait J, Wallace J (2002) Stress at work: a study of organizational-professional conflict and unmet expectations. *Relations Industrielles/Industrial Relations* 57(3):463–490
- Lambert EG, Qureshi H, Frank J, Klahm C, Smith B (2018) Job stress, job involvement, job satisfaction, and organizational commitment and their associations with job burnout among Indian police officers: a research note. *J Police Crim Psychol* 33(2):85–99
- Leung M, Ng ST, Skitmore M, Cheung S (2005) Critical stressors influencing construction estimators in Hong Kong. *Constr Manag Econ* 23(1):33–44
- Li N, Huang J, Feng Y (2020b) Human performance modeling and its uncertainty factors affecting decision making: a survey. *Soft Comput* 24(4):2851–2871
- Li M, Shu Q, Huang H, Bo W, Wang L, Wu H (2020a) Associations of occupational stress, workplace violence and organizational support on chronic fatigue symptoms among nurses. *J Adv Nurs* 76(5):1151–1161
- Liu CH (2020) Strategies of managing coach driver job stress for sustainable coach tourism industry—the use of DANP-V model. *Sustainability* 12(9):3690
- Liu CH, Tzeng GH, Lee MH, Tseng HL, Lee PY (2012) Using a hybrid MCDM model combining fuzzy DEMATEL technique to examine the job stress of coach driver. In: Watada J, Watanabe T, Phillips-Wren G, Howlett RJ, Jain LC (eds) *Intelligent decision technologies*. Springer, Berlin, Heidelberg, pp 149–156
- MacIntyre PD, Gregersen T, Mercer S (2020) Language teachers' coping strategies during the Covid-19 conversion to online teaching: correlations with stress, wellbeing and negative emotions. *System* 94:102352. <https://doi.org/10.1016/j.system.2020.102352>
- McDonald N, Ronayne T (1989) Jobs and their environment: the psychological impact of work in noise. *Ir J Psychol* 10(1):39–55
- Milner A, Witt K, LaMontagne AD, Niedhammer I (2018) Authors' reply: 'response to: 'psychosocial job stressors and suicidality: a meta-analysis and systematic review' by Milner et al.' *Occup Environ Med* 75(4):318
- Nunes LC, Pinheiro PR, Pinheiro MCD, Simão Filho M, Nunes REC (2018) Toward a novel method to support decision-making process in health and behavioral factors analysis for the composition of IT projects teams. *Neural Comput Appl* 32(15):11019–11040
- Pena J, Nápoles G, Salgueiro Y (2020) Explicit methods for attribute weighting in multi-attribute decision-making: a review study. *Artif Intell Rev* 53(5):3127–3152
- Pinto JK, Dawood S, Pinto MB (2014a) Project management and burnout: implications of the demand–control–support model on project-based work. *Int J Project Manage* 32(4):578–589
- Rajabi F, Jahangiri M, Molaeifar H, Honarbakhsh M, Farhadi P (2018) Occupational stress among nurses and pre-hospital emergency staff: application of fuzzy analytic hierarchy process (FAHP) method. *EXCLI J* 17:808
- Rajabi F, Molaeifar H, Jahangiri M, Taheri S, Banaee S, Farhadi P (2020) Occupational stressors among firefighters application of multi-criteria decision making (MCDM) Techniques. *Heliyon* 6(4):e03820
- Rezaei J (2015) Best-worst multi-criteria decision-making method. *Omega* 53:49–57. <https://doi.org/10.1016/j.omega.2014.11.009>
- Rezaei J (2016) Best-worst multi-criteria decision-making method: some properties and a linear model. *Omega* 64:126–130
- Rezaei J, Nispeling T, Sarkis J, Tavasszy L (2016) A supplier selection life cycle approach integrating traditional and environmental criteria using the best worst method. *J Clean Prod* 135:577–588
- Sadeghi M, Garosi A (2017) Personality traits predicting job burnout among staff (case study: central bank of the Islamic Republic of Iran). *World Sci News* 62:64–78
- Sayee Kumar M, Karthik GM, Puhazholi S (2019) Hybrid intelligence system using fuzzy inference in cluster architecture for secured group communication. *Soft Comput* 23(8):2727–2734
- Semmer NK (2006) Job stress interventions and the organization of work. *Scand J Work Environ Health* 32(6):515–527
- Senaratne S, Rasagopalasingam V (2016) The causes and effects of work stress in construction project managers: the case in Sri Lanka. *Int J Constr Manag* 17(1):65–75
- Simon HA (1977) *The new science of management decision*. Prentice-Hall, Englewood Cliffs, NJ
- Siu O (2002) Occupational stressors and well-being among Chinese employees: the role of organisational commitment. *Appl Psychol* 51(4):527–544
- Sunay A, Altan A, Belge E, Hacıoğlu R (2020) Investigation of route tracking performance with adaptive PID controller in quadrotor. *Eur J Tech* 10(1):160–172
- Taap Manshor A, Fontaine R, Siong Choy C (2003) Occupational stress among managers: a Malaysian survey. *J Manag Psychol* 18(6):622–628
- Terry DJ, Tonge L, Callan VJ (1995a) Employee adjustment to stress: the role of coping resources, situational factors, and coping responses. *Anxiety Stress Coping* 8(1):1–24
- Ullah K, Khan MS, Lakhari MT, Vighio AA, Sohu S (2018) Ranking of effects of construction delay: evidence from Malaysian building projects. *J Appl Eng Sci* 8(1):79–84
- Verma, V. (1996). *The human aspects of project management: human resource skills for the project manager*, volume two
- Wagman P, Ahlstrand I, Björk M, Håkansson C (2020) Occupational balance and its association with life satisfaction in men and women with rheumatoid arthritis. *Musculoskeletal Care* 18(2):187–194
- Witte HD (1999) Job insecurity and psychological well-being: Review of the literature and exploration of some unresolved issues. *Eur J Work Organ Psy* 8(2):155–177

Publisher's Note Springer Nature remains neutral with regard to jurisdictional claims in published maps and institutional affiliations.