

A COMBINATION OF ESSENTIAL FATTY ACIDS, PANAX GINSENG EXTRACT, AND GREEN TEA CATECHINS MODIFIES BRAIN FMRI SIGNALS IN HEALTHY OLDER ADULTS

O.T. CARMICHAEL¹, S. PILLAI¹, P. SHANKAPAL², A. MCLELLAN³, D.G. KAY³,
B.T. GOLD⁴, J.N. KELLER¹

1. Pennington Biomedical Research Center, Baton Rouge, LA, USA; 2. MS Ramaiah University of Applied Sciences, India; 3. Neurodyn, Inc, Charlottetown, Prince Edward Island, Canada; 4. University of Kentucky, Lexington, KY, USA. Corresponding author: Owen Carmichael, Pennington Biomedical Research Center, 6400 Perkins Road, Baton Rouge, LA, 70808, USA, Owen.Carmichael@pbrc.edu

Abstract: *Objectives:* To assess the effects of a combination of omega 3 essential fatty acids, green tea catechins, and ginsenosides on cognition and brain functioning in healthy older adults. *Design:* Double-blind, placebo-controlled, crossover design randomized controlled trial with 26-day intervention phases and a 30-day washout period. *Setting:* The Institute for Dementia Research and Prevention at the Pennington Biomedical Research Center. *Participants:* Ten independently-living, cognitively-healthy older adults (mean age: 67.3 + 2.01 years). *Intervention:* Daily consumption of an investigational product (trade name “Cerbella TM”) consisting of an emulsified liquid combination of standardized fish oil, panax ginseng extract, and green tea catechins in a flavored base of lecithin phospholipids optimized to maximize bioavailability of the active ingredients. *Measurements:* Before and after supplementation with the investigational product or placebo, participants completed cognitive tests including the Mini Mental State Exam (MMSE), Stroop test, Digit Symbol Substitution Test (DSST), and Immediate and Delayed Recall tests, as well as functional magnetic resonance imaging (fMRI) during a standard cognitive task switching paradigm. *Results:* Performance on the MMSE, Stroop test, and DSST increased significantly over one month of supplementation with the investigational product (one-sample t tests, $p < .05$) although differences between these changes and corresponding changes during supplementation with placebo were not significant (two-sample t tests, $p > .05$). During supplementation with the investigational product, brain activation during task performance increased significantly more than during supplementation with placebo in brain regions known to be activated by this task (anterior and posterior cingulate cortex). Functional connectivity during task execution between task regions (middle frontal gyrus and anterior cingulate cortex) increased significantly during supplementation with the investigational product, relative to placebo. Functional connectivity during rest between task regions (precentral gyrus and middle frontal gyrus) and default mode network regions (medial frontal gyrus and precuneus) decreased during supplementation with the investigational product relative to placebo, suggesting greater segregation of task and rest related brain activity. *Conclusion:* One-month supplementation with a combination of omega 3 essential fatty acids, green tea catechins, and ginsenosides was associated with suggestive changes in cognitive functioning as well as modification of brain activation and brain functional connectivity in cognitively healthy older adults.

Key words: Cognitive aging, fMRI, fish oil, panax ginseng extract, green tea catechins.

Introduction

The number of individuals aged 65 or older worldwide is increasing steadily over time, from approximately 46 million to 98 million between 2016 and 2060 in the United States alone (2). Accompanying this increase is an increase in the prevalence of brain diseases of aging, including stroke and dementia, whose risks increase substantially late in the lifespan (4-7). These brain diseases incur an astounding societal burden; for example, the total economic cost of AD (AD) was estimated to be \$604 billion in 2010 (8). Because risks of these brain diseases rise steadily with age, a large body of current research is concerned with neuroprotection—the preservation of brain structure and functioning in healthy older adults with a goal of delaying or reducing risk of brain diseases of aging (9-11). Even delaying the onset of such diseases would have a major impact on prevalence: for example, one estimate is

that delaying onset and progression of AD by as little as one year could reduce the number of cases globally by as many as 9.2 million (12). The importance of such a preventive approach is underlined by the limited success to date of several disease modifying agents tested on symptomatic individuals in rigorously designed clinical trials, especially those in AD (13, 14).

Converging data from epidemiology and animal models suggests that omega 3 essential fatty acids (EFAs), ginsenosides, and green tea catechins may have neuroprotective effects (15-17). Large epidemiological studies have suggested that individuals who consume diets rich in EFAs or green tea catechins have lower risks of stroke, dementia, and cognitive decline (18-26). Animal studies have suggested that EFA supplementation enhances learning and memory in aged animals (27). Green tea catechins, besides enhancing neurological function in animal models, also reduces the

A COMBINATION OF ESSENTIAL FATTY ACIDS, PANAX GINSENG EXTRACT, AND GREEN TEA CATECHINS

toxicity of AD and Huntington's Disease pathologies in animal models and cell culture systems (28, 29). Ginsenosides enhance memory function in animal models of vascular dementia (30), and appear to blunt the production and toxicity of AD pathology in cell culture systems (31). Because EFAs, ginsenosides, and green tea catechins are widely consumed and well tolerated food products with complementary and potentially synergistic biological mechanisms of action, these results suggest that they are promising non-pharmacological candidate neuroprotective agents for older adults.

However, clinical trial evidence that supplementing the diets of healthy older adults with EFAs, ginsenosides, or green tea catechins individually enhances brain health or cognitive functioning has been mixed. Ginseng and ginseng extracts have been shown to improve cognitive performance in healthy volunteers, as well as subjects suffering from vascular dementia and AD (32, 33). EFAs have been shown to improve learning and memory in healthy middle aged and older adults with age related cognitive decline (34). Further, supplementation with EFAs has been shown to improve cognition and modify brain activation (measured by fMRI) in healthy young (35) and older (36) adults. Observational studies suggest that greater tea consumption may be associated with lower incidence of cognitive decline and greater health-related quality of life (37, 38). A combination of green tea extract and l-theanine led to improvements in memory and selective attention while significantly increasing brain theta waves, an electroencephalography (EEG) indicator of cognitive alertness (39). Recently, green tea was shown to have a beneficial effect on working memory in healthy adults as well as modification of brain functioning as measured by fMRI (40). However, systematic reviews suggest that these individual studies fall short of a large, highly convincing body of rigorous clinical trial evidence for an impact of ginsenosides (41-43), EFAs (44-46), or green tea catechins (47) on cognitive functioning, either in healthy individuals or those with dementia. With few exceptions (35, 39, 40), the impact these compounds have on brain functioning has not been deeply explored. One potential limitation of previous investigations is the well-accepted limited bioavailability, both in plasma and brain, of these compounds in their native form (48). In addition, the effects that combinations of these compounds may have on cognition and brain function are not well studied. These unknowns limit the ability to make recommendations to older adults about oral supplementation with combinations of EFAs, green tea catechins, and ginsenosides.

Therefore, we undertook a double-blind, placebo-controlled, randomized crossover design clinical trial of a proprietary combination of EFAs, green tea catechins, and panax ginseng extract, (trade name "Cerbella TM") in healthy older adults. Cerbella TM was formulated to maximize bioavailability of the active ingredient by chemically complexing the green tea catechin and ginsenoside compounds with phospholipid carriers and providing the EFAs in emulsified form. Following prior

reports that roughly 4 to 6 weeks of supplementation with botanical products can impact cognitive or affective outcomes (49-59), we sought to determine whether consumption of this combination daily over the course of approximately 26 days was associated with greater cognitive changes and changes to fMRI measures of brain functioning than consumption of a placebo daily over the same length of time.

Methods

Investigational product

The investigational product contained a liquid emulsification which combined standardized fish oil, panax ginseng phospholipid complex, and green tea catechin phospholipid complex in a flavored base. The format was a safety sealed 16 oz bottle containing 28 doses of 10ml each. The daily dose delivered was 16 mg total ginsenosides, 960 mg EPA, 624 mg DHA, and 26 mg of green tea catechins. Subjects were asked to take the daily dose in two divided doses with the morning and evening meal. The placebo was an oil in water emulsion using non essential fatty acid containing corn oil without the addition of ginsenosides or catechins, but matched to the active product by taste, color, odor, and texture. The investigational product and matching placebo were manufactured by a fully GMP site licensed manufacturer. Stability studies were conducted to ensure stability of the active ingredients during the study period, including minimal oxidation of the fish oil ingredient. All active ingredients were confirmed by HPLC analysis. Quality control screening consisted of pesticide residue, heavy metal, solvent residues, microbiology and loss on drying, all according to USP guidelines.

Participants

The Institute for Dementia Research and Prevention (IDRP) at Pennington Biomedical Research Center (PBRC) was utilized to enroll 10 non-demented older adults using fliers, website, and email contact. Inclusion criteria included age between 55 and 75 years, MMSE score of 25 or greater, and ability to undergo MRI examination. Exclusion criteria included a clinical diagnosis of AD or other dementia, usage of medications for treatment of dementia, usage of medical foods for treatment of dementia, usage of brain health supplements within 30 days of screening (including EFA, ginseng, and green tea catechins), a Geriatric Depression Scale greater than 6, pregnancy or lactation, medical conditions or diseases that are life threatening, and usage of cigarettes or other nicotine containing products.

Study design

The study used a cross-over design in which subjects were initially randomized to receive a 26 day treatment of either the placebo or investigational product. Following a 30-day washout period subjects completed the second arm of the study using identical procedures and methodologies as the first

arm. A 30 day washout period was justified for essential fatty acid intake based on no significant difference from baseline levels of fatty acids after 30 days post supplementation (60). Similarly, previous studies of rapid metabolic clearance of tea catechins suggest that a 4 week washout is more than adequate after regular intake (61). In addition, there were no significant differences in baseline scores of cognitive function before treatment or after a 7 day post treatment washout period following subchronic panax ginseng standardized extract administration (62). Participants were clinically evaluated at the beginning and end of each intervention phase. Each clinical evaluation included cognitive testing, MRI scanning, supplement compliance review, adverse event reporting, and Geriatric Depression Scale assessment. Subjects and all research staff that participated in data collection were blinded to intervention assignment. The crossover design was balanced, meaning that an equal number of individuals were randomized to receive placebo in the first phase of the study and to receive the investigational product in the first phase.

Cognitive testing

At each clinical evaluation, subjects completed a battery of cognitive tests including the MMSE (a global measure of cognition (63)), the DSST (a measure of attention and psychomotor speed (64)), the Stroop test (a measure of processing speed and executive function (65)), and Logical Memory I and II (measures of immediate and delayed recall (66)).

fMRI image acquisition and stimulus presentation system

Participants received MRI scans on a GE Discovery 750w 3.0T scanner with a 32-channel head coil. Participants wore a respiratory monitoring belt and pulse oxygenation sensor during scanning to allow post-hoc correction of cardiac and respiratory influences on fMRI using the RETROICOR algorithm (67). EPI BOLD fMRI data was collected with the following parameters: Voxel size: 3x3x3 mm, 96x96 matrix, 43 axial slices, TR: 3000 ms, TE: 35 ms, flip angle: 90, bandwidth: 250, NEX: 1, single shot. Participants also received a 3D T1-weighted FSPGR BRAVO structural acquisition for anatomical reference. Key parameters include: voxel size: 0.94x0.94x1.2 mm, 256x256 matrix, 140 sagittal slices, TR:8.5, TE:3.3, TI:450 ms, flip angle:12, bandwidth:31.25, NEX:2, Time: 3:22.

fMRI task

Participants completed a task switching cognitive paradigm described previously, during collection of fMRI data (68). Briefly, each trial consisted of presentation of a cue for 150 ms, followed by a stimulus for 2650 ms, followed by a fixation (+) for 200 ms. Each cue consisted of either the word "SHAPE" or the word "COLOR" in black text. Stimuli consisted of two possible shapes (circle or square), in one of two possible colors (red or blue), presented in the center of the screen. When the cue was "SHAPE," participants were instructed to click

a button in the left or right hand depending on whether the stimulus was a circle or square; when the cue was "COLOR," participants were instructed to click a button in the left or right hand depending on whether the stimulus was blue or red. Participants were asked to respond as quickly and accurately as possible to each trial. A block design was employed with 4 types of blocks: one in which the cue was always "SHAPE," one in which the cue was always "COLOR," one in which the cue alternated between "SHAPE" and "COLOR," and a fixation block. Within each run, individual task blocks (60 seconds in duration) were separated by fixation blocks (30 seconds). The fixation blocks are referred to as "rest blocks." Three separate 6-minute runs of the task were collected. The first run contained two shape blocks and two color blocks; the others contained one shape block, one color block, and two alternating blocks. The order of runs, blocks within runs, and stimulus-response mappings were counterbalanced across participants. The experiment was programmed in E-Prime v1.2 (Psychology Software Tools, Pittsburgh, PA).

fMRI data processing

Preprocessing of fMRI data used Statistical Parametric Mapping 12 (SPM12). Preprocessing included slice timing correction, head motion correction, smoothing with a Gaussian kernel (6 mm full width at half maximum), co-registration to the T1-weighted scan, and warping the T1-weighted data and thus fMRI data to a standard coordinate frame. Cardiac and respiratory components of the time series were removed using the RETROICOR algorithm (67). Time points exhibiting excess head motion (defined as greater than 1.5 degrees of rotation or 1.5 mm of translation) were identified and removed from the analysis.

fMRI activation analysis

Each participant's data for each condition was entered into a first-level voxel-wise analysis using the general linear model. Each block was modeled as a boxcar function convolved with the canonical hemodynamic response function that begins at the onset of the first image in the block and ends at the end of the block, in which all trials within a block are modeled relative to rest blocks. Second-level beta maps quantified, at an individual level, differences in the BOLD signal according to our primary contrasts of interest: between the set of shape and color blocks on one hand, and the set of alternating blocks on the other hand. Third-level group analyses asked whether changes in the second-level beta maps over the course of each intervention phase (investigational product and placebo) differed significantly from zero, and whether changes over the investigational product phase differed significantly from changes over the placebo phase. Third-level analyses resulted in P value maps that were corrected for multiple comparisons using AlphaSim (1), with a voxel-level p value threshold of .01 and a cluster-level significance threshold of .001. All analyses were performed in SPM12.

A COMBINATION OF ESSENTIAL FATTY ACIDS, PANAX GINSENG EXTRACT, AND GREEN TEA CATECHINS

fMRI functional connectivity analysis

Functional connectivity analysis assessed the degree to which the fMRI signal showed synchronicity between distinct locations in the brain. Briefly, a set of regions of interest (ROIs) known to be activated by this task were identified based on prior reports with this task (68, 69). The ROIs consisted of the left medial frontal gyrus, left middle frontal gyrus, left and right precentral gyri, left and right anterior dorsal premotor cortex, and left superior parietal lobule. For each such task ROI, the mean fMRI time series during task performance blocks was estimated within a 9mm sphere centered on a seed voxel within the ROI. The Pearson correlation between this task mean time series and corresponding task time series in all other brain voxels was estimated to quantify functional connectivity during task execution. Similarly, for each task ROI, the mean fMRI time series during rest blocks was estimated within a 9mm sphere centered on the ROI seed voxel. The Pearson correlation between this mean rest block time series and corresponding rest block time series in all other brain voxels was estimated to quantify functional connectivity during rest. Change in functional connectivity values over the course of each intervention phase were calculated at an individual level. Group level analysis assessed whether such functional connectivity changes over each intervention phase were significantly different from zero and whether such changes differed significantly between the investigational product and placebo phases. These analyses resulted in p value maps that were corrected for multiple comparisons using AlphaSim with a voxel-level p value threshold of .01 and a cluster-level significance threshold of .001. All analyses were performed in SPM12.

Analysis of cognitive endpoints

Individual change over the course of each intervention phase in each cognitive test was calculated. Group-level analysis used two-sided one-sample t-tests to assess whether such changes were significantly different from zero within each intervention phase. Group analysis also used paired two-sided two-sample t-tests to assess whether the changes differed significantly between investigational product and placebo phases. The distributions of cognitive test scores were checked for skewness and transformed to encourage normality as needed prior to analysis. We used two-sample T tests to compare cognitive changes between those who received the investigational product during the first intervention phase, and those who received the investigational product during the second intervention phase. Significant differences in these latter tests could suggest that cognitive changes may have been influenced by the number of exposures to the cognitive test instruments. Analysis of cognitive tests was performed in R version 2.13.0.

Results

Participant characteristics

A participant flow diagram for this study is shown in Figure 1. Fifty members of the IDRP internal registry were contacted via email. Among those individuals, 14 contacted the IDRP expressing interest in the study. All 14 individuals met inclusion criteria and were eligible for the study. Three eligible individuals declined to participate due to lack of interest. The remaining eleven individuals were enrolled in the study. One of these individuals dropped out of the study after the first MRI exam due to MRI discomfort. The remaining ten enrolled individuals completed the study, including 6 females and 4 males (Table 1). These individuals had a mean age of 67.3 years + 2.01 years. Mean educational attainment was high (15.67 years + 0.73 years). The average BMI of participants was within the range of normal weight (23.30 + 0.93). All participants consumed greater than 90% of prescribed doses of placebo and the investigational product, based on participant questioning and the weighing of fluids at study visits.

Table 1
Participant characteristics

Age (mean +/- standard deviation)	67.3 + 2.01 years
Sex (% male, % female)	60%, 40%
Weight	149.8 + 8.21 pounds
BMI	23.30 + 0.93
History of hypertension	33%
History of elevated cholesterol	56%
History of diabetes	0%

Figure 1
Participant flow diagram for the study

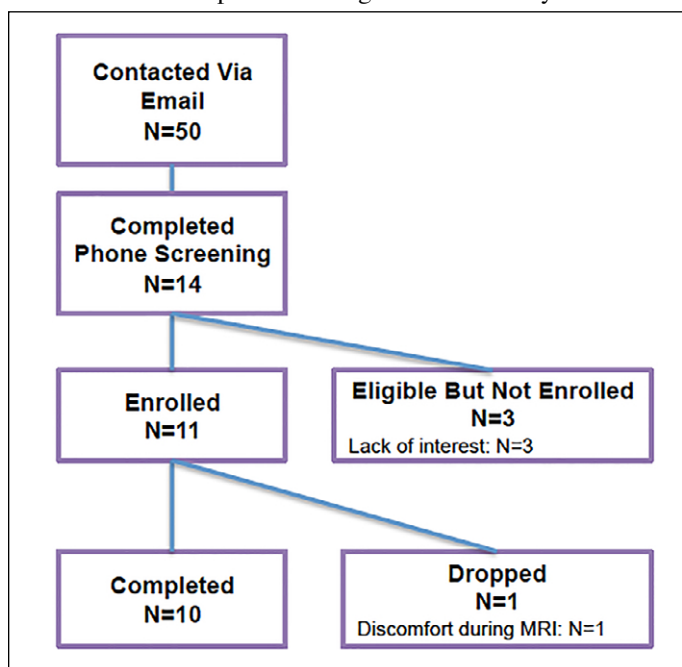

Table 2

Cognitive function and fMRI summary measures before and after the placebo and investigational product phases of the intervention, and change in these measures over the course of each intervention phase

	Placebo			Investigational Product		
	Pre	Post	Change	Pre	Post	Change
<i>Cognitive Function</i>						
MMSE	29.40 +/- 0.70	29.60 +/- 0.97	0.20 +/- 1.03	28.90 +/- 1.29	29.80 +/- 0.42	0.90 +/- 1.10*
Stroop	98.90 +/- 14.92	103.70 +/- 9.26	4.80 +/- 7.22	95.40 +/- 18.86	102.00 +/- 13.83	6.60 +/- 8.71*
Immediate Recall	15.70 +/- 3.83	16.60 +/- 3.27	0.90 +/- 4.28	16.60 +/- 4.03	17.20 +/- 2.82	0.60 +/- 3.06
Delayed Recall	13.80 +/- 3.49	15.20 +/- 4.59	1.40 +/- 3.66	14.20 +/- 3.65	16.00 +/- 3.97	1.80 +/- 2.82
Digit Symbol	56.70 +/- 10.17	59.30 +/- 9.39	2.60 +/- 8.53	55.80 +/- 9.68	59.10 +/- 10.42	3.30 +/- 2.75*
<i>fMRI Task Activation</i>						
Anterior Cingulate	.159 +/- .266	-.113 +/- .420	-.273 +/- .560	-.238 +/- .213	.361 +/- .359	.599 +/- .464
Posterior Cingulate	.390 +/- .314	-.145 +/- .274	-.535 +/- .344	.080 +/- .40	.534 +/- .295	.455 +/- .532
<i>fMRI Functional Connectivity During Task Execution</i>						
Middle frontal gyrus— anterior cingulate cortex	1.35+/- .21	.52+/- .39	-.83+/- .44	.61+/- .39	1.53+/- .60	.90+/- .53
<i>fMRI Functional Connectivity During Rest</i>						
Medial frontal gyrus – occipital cortex	1.02+/- .36	1.17+/- .42	.15+/- .53	-.35+/- .74	1.3+/- .47	1.57+/- 1.16
Precentral gyrus-Medial frontal gyrus	.14+/- .65	1.28+/- .68	1.13+/- 1.03	.84+/- .37	.18+/- .45	-.54+/- .63
Precuneus—middle frontal gyrus	.16+/- .83	1.16+/- .32	1.0+/- .82	.99+/- .55	.22+/- .66	-.48+/- .91

*Cognitive changes significantly differ from 0 at p<.05 level via two-sided one-sample T test. Significant differences from zero are not denoted for fMRI measures to avoid the appearance of “double dipping” as the fMRI summary measures were calculated from sets of voxels identified through a different statistical test [3]. The fMRI measures are listed here for illustrative purposes only.

Adverse events

A total of 6 adverse events were reported over the course of the study including nasal congestion (1), persistent cold (1), nausea-vomiting (1), and wrist, knee and elbow pain (3). No serious adverse events were reported over the course of the study. No adverse event appeared to be related to treatment with either placebo or the investigational product. There was no significant difference between the placebo and investigational product intervention phases in the number of adverse events reported, suggesting that the investigational product did not significantly increase adverse events as compared to placebo.

Cognitive changes

Increases in scores on the MMSE, Stroop, and Digit Symbol tests over the course of treatment with the investigational product were statistically significant (all p<.05, see Table 2). Mean changes in scores on all tests during the placebo phase, as well as changes in scores on the Immediate and Delayed Recall tests during the investigational product phase, were positive, but not significantly different from 0 (p>.05). Differences in cognitive test score changes between placebo and interventional product phases were not significant in paired 2-sample t-tests (p>.05). Differences in cognitive changes during the investigational product phase between those who received the investigational product during the first intervention phase, and those who received the investigational product during the second intervention phase, were not significant (all p

values .40 or greater). Differences in cognitive changes during the placebo phase between those who received placebo during the first intervention phase, and those who received placebo during the second intervention phase, were also not significant (all p values .07 or greater).

fMRI task activation changes

Significant decreases in fMRI signal differences between the set of shape-only blocks and color-only blocks on one hand, and the set of alternating blocks on the other hand, over the course of the placebo phase were observed in a cluster of voxels located in the posterior cingulate cortex (Figure 2). Significant changes over the course of the investigational product phase were mixed, including significant increases in a cluster of voxels mainly within the cerebellum and brainstem, as well as significant decreases in small clusters of voxels covering portions of midline white matter tracts. Comparison of placebo and investigational product phases suggested that increases in fMRI signal differences between the set of shape-only blocks and color-only blocks on one hand, and the set of alternating blocks on the other hand, over the course of the investigational product phase were significantly greater than they were over the course of the placebo phase in two clusters of voxels, located in the anterior and posterior cingulate cortex respectively. In both clusters, the average BOLD signal change over the investigational product phase was positive, while the average BOLD signal change over the placebo change was negative

A COMBINATION OF ESSENTIAL FATTY ACIDS, PANAX GINSENG EXTRACT, AND GREEN TEA CATECHINS

(Table 2).

fMRI functional connectivity changes

Functional connectivity during rest blocks between the medial frontal gyrus ROI and a voxel cluster in the occipital cortex increased significantly over the course of treatment with the investigational product but was roughly unchanged during treatment with placebo (Figure 3, Table 2). Functional connectivity during rest blocks between the precentral gyrus ROI and a cluster of voxels in the medial frontal gyrus increased significantly over the course of treatment with placebo, and decreased significantly over the course of treatment with Cerbella. Functional connectivity during rest blocks between the precuneus ROI and a cluster of voxels in the middle frontal gyrus also increased significantly over the course of treatment with placebo, and decreased significantly over the course of treatment with the investigational product. Average functional connectivity across all task blocks between the middle frontal gyrus ROI and a cluster of anterior cingulate cortex voxels decreased over the course of treatment with placebo but increased over the course of treatment with the investigational product (Figure 4, Table 2). Other differences in task or rest functional connectivity between placebo and investigational product phases were not statistically significant.

Figure 2

fMRI activation changes over the course of intervention with the investigational product and placebo

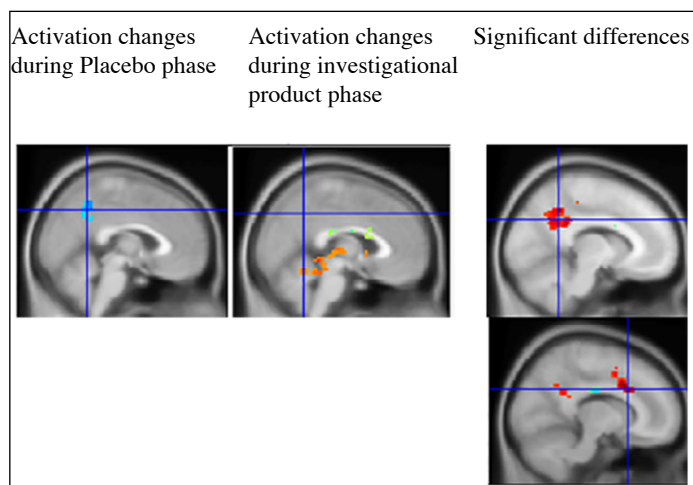

Left: fMRI signal changes among those on placebo included mainly decreases in the fMRI signal, including decreases in a posterior cingulate cortex cluster (shown in blue). Center: fMRI signal changes among those on the investigational product consisted of a combination of signal increases (shown in orange) and decreases (shown in green). Right: Locations where the differences in fMRI changes between the investigational product and placebo arms were statistically significant are shown in red. Red regions showed greater increases in activation over the intervention in the investigational product arm compared to the placebo arm. These regions include the posterior and anterior cingulate cortex, regions important to task execution. All maps show differences that are significant at the voxel level at a level of $p=.01$, and a cluster significance threshold of $p=.001$ using AlphaSim cluster correction (1).

Figure 3

Changes in functional connectivity (FC) with medial frontal gyrus (MeFG, top row), precentral gyrus (PCG, middle row), and precuneus (PREC, bottom row) seed locations during task execution, over the course of each intervention phase

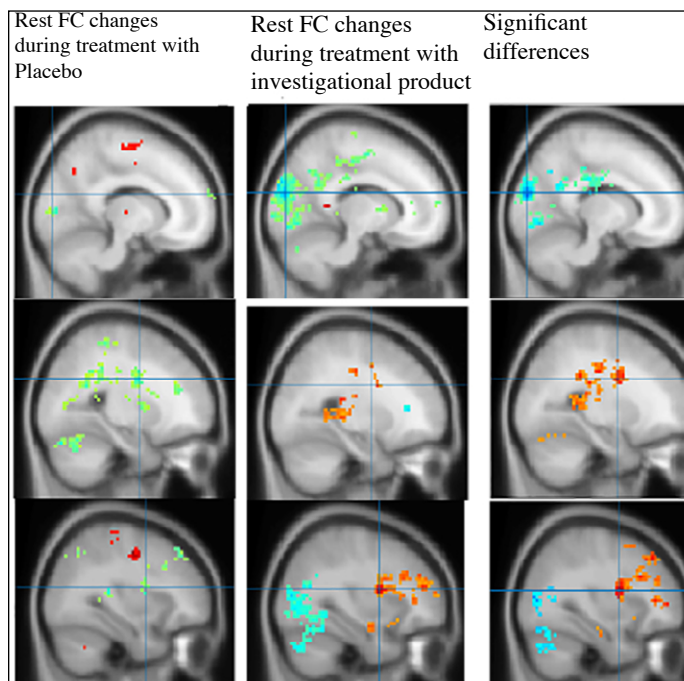

Top row: Rest FC between MeFG and an occipital cortex ROI increased significantly during treatment with the investigational product (middle column, cool colors) but was largely unchanged over treatment with placebo (left column). Middle row: Rest FC between PCG and MeFG increased significantly over the course of treatment with placebo (cool colors, left column) but was largely unchanged over treatment with the investigational product. Bottom row: Rest FC between PREC and a middle frontal gyrus ROI decreased significantly over the course of treatment with the investigational product (hot colors, middle column) and increased significantly over the course of treatment with placebo (cool colors, left column). All maps show differences over time that are significant at the voxel level at a level of $p=.01$ and a cluster significance threshold of $p=.001$ using AlphaSim cluster correction (1).

Discussion

In this double blind placebo controlled study, ten cognitively healthy older adults underwent roughly one-month oral supplementation with an investigational product containing green tea catechins, ginseng extract, and EFAs; and a placebo, in a crossover design. Supplementation with placebo was associated with mean increases in performance on all cognitive tests, suggestive of practice effects, although these increases were not statistically significant. Supplementation with the investigational product was associated with statistically significant increases on three out of five cognitive measures collected, suggestive of a possible combination of practice effects and effects of the investigational product; although direct comparison of changes between investigational product and placebo phases found no significant differences. In addition, supplementation with the investigational product was associated with significantly greater increases in brain

activation during execution of a cognitive task, compared to supplementation with placebo. Over the course of the intervention, supplementation with the investigational product was associated with significantly different changes in brain functional connectivity during execution of a cognitive task, compared to supplementation with placebo. Finally, supplementation with the investigational product was associated with significantly different changes in brain functional connectivity during rest periods, relative to supplementation with placebo. Taken together, these findings suggest that ingesting the investigational product for a roughly one-month period may be associated with changes in brain functioning during task execution and rest, with resultant changes in cognitive performance.

Figure 4

Changes in functional connectivity (FC) with a middle frontal gyrus (MFG) seed location during task execution, over the course of each intervention phase

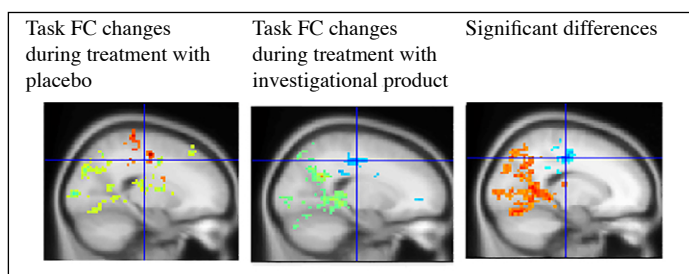

Left: Task FC changes during treatment with placebo include a combination of increases (cool, green colors) and decreases (hot colors). Center: Task FC changes during treatment with the investigational product include mainly increases (cool colors). Right: Task FC between the MFG and locations mainly within the occipital cortex decreased significantly more during treatment with the investigational product than it did during treatment with placebo (hot colors). However, task FC between the MFG and locations within the cingulate cortex increased significantly more during treatment with Cerbella than it did during treatment with placebo (cool colors). All maps show differences over time that are significant at the voxel level at a level of $p=.01$ and a cluster significance threshold of $p=.001$ using AlphaSim cluster correction (1).

The finding of increases in fMRI signal differences during supplementation with the investigational product is consistent with a role for the investigational product in increasing the vigor of brain engagement with the fMRI task. The task switching paradigm is known to activate a set of critical brain regions, including the anterior cingulate, medial frontal, middle frontal, and precentral gyri (68). The role of posterior cingulate cortex in task switching is less clear, with fMRI studies alternatively detecting a significant role for it (70-73), or not (68, 69). Differences in brain activation between switching and non-switching task blocks in the anterior and posterior cingulate gyri increased significantly over the course of treatment with the investigational product, relative to treatment with placebo. To the extent that these regions were involved in task switching, this finding is consistent with the notion that consuming the investigational product was associated with an increase in the vigor of brain responses to the cognitive demands of the task. Such intervention-related increases in response vigor during

an fMRI task, in brain regions hypothesized to be involved in accomplishing the task, has been observed in several prior studies, lending plausibility to the current results (36, 74, 75). Although these results are a promising signal that the investigational product could be enacting changes to brain functioning related to task performance, future work is required to determine the real-world relevance of these particular increases in response vigor, for example using neuromodulation techniques to modify activation in these areas and observing resulting effects on task performance (76).

Figure 5

Hypothesized ingredient-specific and ingredient-shared effects of the investigational product on the brain

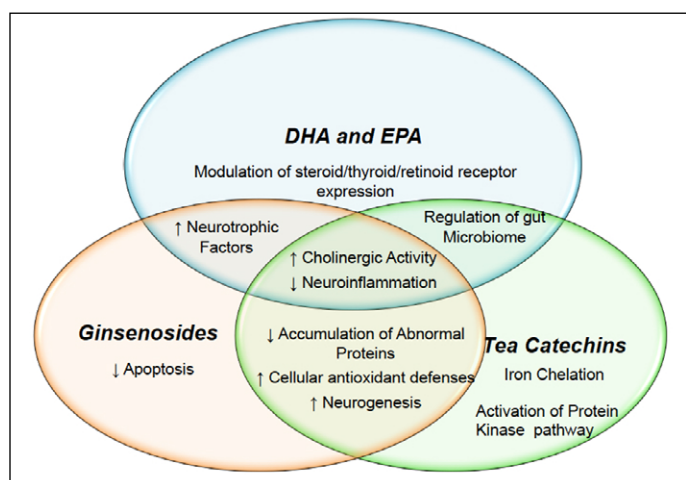

The fMRI functional connectivity findings are consistent with a role for the investigational product in changing the engagement of distributed neural networks during task execution and rest. As mentioned before, execution of the fMRI task requires activation of a task network of brain regions that includes the anterior cingulate cortex and the middle frontal gyrus. In addition, there is a distributed network of regions, commonly referred to as the default mode network, that activates in a synchronous fashion during periods of rest, possibly to facilitate introspective cognition such as re-evaluation of recently perceived series of events. Previous work has suggested that task networks such as the current one show highly structured, temporally synchronous patterns of BOLD signal fluctuations during task performance (77). Conversely, the default mode network shows highly structured, temporally synchronous patterns of BOLD signal fluctuations in the absence of an overt cognitive or sensory task (78), and this synchrony reduces markedly during performance of tasks (79-81). A large body of research has linked lesser synchrony of the default mode network during rest to poorer cognitive functioning as well as the presence of clinically significant neurological disorders, including AD and Parkinson's disease (82-85). In addition, individuals with poorer cognitive function show a reduced ability to modulate functional connectivity

A COMBINATION OF ESSENTIAL FATTY ACIDS, PANAX GINSENG EXTRACT, AND GREEN TEA CATECHINS

between default and task networks (86, 87). We found that fMRI signal synchrony between two default mode network structures (the medial frontal gyrus and precuneus (88) respectively) and two task network structures (the precentral gyrus and middle frontal gyrus respectively) reduced during rest over the course of treatment with the investigational product. This is consistent with the notion that after a course of treatment with the investigational product, the default mode network is less engaged with the task network during rest. In addition, we found that functional connectivity between a pair of task network structures (anterior cingulate and middle frontal gyri) during task execution increased during treatment with the investigational product. This is consistent with the notion that during treatment with the investigational product, the task network has greater synchrony of activity within the network during task performance. Both of these characteristics—lesser synchrony between task and default mode networks during rest, and greater synchrony within the task network during task execution—have been associated with cognitive health and greater cognitive performance. While the observation of these changes during treatment with the investigational product is promising, the relevance of both types of fMRI signal changes to cognitive functioning in the longer term should be explored further in a larger population.

Prior work has identified a number of putative mechanisms by which treatment with the investigational product may have elicited the observed changes to brain activation and functional connectivity. Primate studies have suggested that supplementation with EFAs leads to greater vascular reactivity to neural activity in older animals (89). EFA supplementation is associated with an increase in the prevalence of synaptic proteins and increased density of dendritic spines in the adult rat brain (90). EFAs also play roles in long-term potentiation and synaptic plasticity, and supplementation could enhance each of those functions (91, 92). The biological functions of green tea catechins relevant to neurological function include free radical scavenging, anti-inflammatory effects, iron chelating, regulation of protein kinase C activity, and induction of endogenous antioxidant defense systems (93, 94). Researchers have attributed the CNS effects of ginsenosides to modification of cerebral metabolism, oxidative stress, free radical formation, neurotransmitter balance, and membrane stabilization (95, 96). Figure 5 summarizes hypothesized effects that are distinct to distinct ingredients, and which are shared among multiple ingredients. Notably, several important brain processes are hypothesized to be modulated by multiple ingredients, including cholinergic signaling, neuroinflammation, neurotrophism, neurogenesis, abnormal protein clearance, and antioxidant pathways. Each of these actions could potentially modify brain activation and functional connectivity, as well as emergent cognitive functioning. It remains to be seen, however, whether one of these specific actions is primarily responsible for changes in brain activation and cognition seen among those taking the investigational

product or whether the effect depends on a cumulative or synergistic relationship between individual ingredients and their respective mechanisms. Future work should endeavor to address the issue of individual contributions of individual ingredients via measurements CNS levels of the ingredients, as well as product formulations that omit one or two of the ingredients.

Although cognitive changes during treatment with the investigational product did not differ significantly from corresponding changes during treatment with placebo, the observed significant differences in fMRI signals between active and placebo treatment could have relevance to longer-term cognitive functioning. It is now well understood that cognitive aging is characterized by long periods of preclinical brain changes—changes in the structural and functional properties of the brain that occur years or even decades prior to the onset of detectable cognitive decline (97-99). Treatments that slow, halt, or even reverse such preclinical brain changes have the potential to induce a beneficial slowing of cognitive decline over the long term, without demonstrating any immediate cognitive benefit over the course of the intervention. Because the observed brain functional changes are promising, it is important to follow up this study with longer term interventions with the investigational product to determine whether in fact these brain changes are beneficial for cognition in the longer term.

This was a small-scale study with inherent limitations. The small sample size precludes a definitive analysis of treatment effects, and recent studies suggest that it could possibly be associated with a higher probability of fMRI false positives (100). The short follow-up time precludes assessment of longer-term cognitive benefits or longer-term changes to brain functioning. Lasting effects of supplementation on cognition or brain function after the cessation of supplementation would be especially valuable to assess. In addition, while the cognitive battery included contributions from several relevant cognitive domains, specific assessments of effects on certain specific domains, such as working memory, was not assessed. Thus, while the observed effects on brain functioning are promising, larger, longer term studies with more exhaustive cognitive batteries are required to more fully characterize the effects of the investigational product.

In conclusion, individuals who consumed an oral supplement containing EPA, DHA, green tea catechins, and ginseng extract (Cerbella (TM)) for 26+/- 2 days experienced suggestive changes in cognitive functioning, as well as changes to brain activation and functional connectivity relative to placebo that are consistent with enhancements in response vigor and brain network modifications.

Ethical standard: This study was overseen by the Institutional Review Board at the Pennington Biomedical Research Center and complied with current laws and regulations regarding biomedical research in the United States.

Disclosures: Dr. Carmichael received contract support from Neurodyn, Inc. for the conduct of the reported clinical trial on Cerbella (TM), for travel, for data analysis, and for

the writing of this manuscript. Cerbella (TM) is a Neurodyn, Inc. product. Dr. Carmichael also received funding from the Pennington Biomedical Research Foundation. Dr. Gold has nothing to disclose. Dr. McLellan reports personal fees from Neurodyn and grants from ACOA during the conduct of the study; personal fees from Neurodyn outside the submitted work. In addition, Dr. McLellan has a patent 62460021 pending related to this manuscript. Dr. Keller received contract support from Neurodyn, Inc. for the conduct of the reported clinical trial on Cerbella (TM). Cerbella (TM) is a Neurodyn, Inc. product. Sreekrishna Pillai has nothing to disclose. Dr. Shankapal has nothing to disclose. Dr. Kay reports personal fees from Neurodyn and grants from ACOA during the conduct of the study; personal fees from Neurodyn outside the submitted work. In addition, Dr. Kay has a patent 62460021 pending related to this manuscript.

References

1. Moore, K.E. and J.E. Brennan. ALPHA/Sim simulation software tutorial. in Proceedings of the 28th conference on Winter simulation. 1996. IEEE Computer Society.
2. Mather, M., Fact Sheet: Aging in the United States. Population Reference Bureau, 2016.
3. Kriegeskorte, N., et al., Circular analysis in systems neuroscience: the dangers of double dipping. *Nat Neurosci*, 2009. 12(5): p. 535-40.
4. Dirnagl, U., C. Iadecola, and M.A. Moskowitz, Pathobiology of ischaemic stroke: an integrated view. *Trends in Neurosciences*, 1999. 22(9): p. 391-397.
5. Bejot, Y., et al., Trends in Incidence, Risk Factors, and Survival in Symptomatic Lacunar Stroke in Dijon, France, From 1989 to 2006 A Population-Based Study. *Stroke*, 2008. 39: p. 1945 - 1951.
6. Hebert, L.E., et al., Alzheimer Disease in the US Population: Prevalence Estimates Using the 2000 Census. *Arch Neurol*, 2003. 60(8): p. 1119-1122.
7. Tilvis, R.S., et al., Predictors of cognitive decline and mortality of aged people over a 10-year period. *The Journals of Gerontology Series A: Biological Sciences and Medical Sciences*, 2004. 59(3): p. M268-M274.
8. Wimo, A., et al., The worldwide economic impact of dementia 2010. *Alzheimer's & Dementia*, 2013. 9(1): p. 1-11. e3.
9. Ravina, B., et al., Neuroprotective agents for clinical trials in Parkinson's disease A systematic assessment. *Neurology*, 2003. 60(8): p. 1234-1240.
10. Scapagnini, G., et al., Modulation of Nrf2/ARE pathway by food polyphenols: a nutritional neuroprotective strategy for cognitive and neurodegenerative disorders. *Molecular neurobiology*, 2011. 44(2): p. 192-201.
11. Kelsey, N.A., H.M. Wilkins, and D.A. Linseman, Nutraceutical antioxidants as novel neuroprotective agents. *Molecules*, 2010. 15(11): p. 7792-7814.
12. Brookmeyer, R., et al., Forecasting the global burden of Alzheimer's disease. *Alzheimer's & dementia*, 2007. 3(3): p. 186-191.
13. Becker, R.E. and N.H. Greig, Alzheimer's disease drug development in 2008 and beyond: problems and opportunities. *Current Alzheimer Research*, 2008. 5(4): p. 346-357.
14. Schneider, L.S. and D.K. Lahiri, The perils of Alzheimer's drug development. *Current Alzheimer Research*, 2009. 6(1): p. 77-78.
15. Cole, G.M., Q.-L. Ma, and S.A. Frautschy, Omega-3 fatty acids and dementia. *Prostaglandins, Leukotrienes and Essential Fatty Acids*, 2009. 81(2): p. 213-221.
16. Calon, F. and G. Cole, Neuroprotective action of omega-3 polyunsaturated fatty acids against neurodegenerative diseases: evidence from animal studies. *Prostaglandins, Leukotrienes and Essential Fatty Acids*, 2007. 77(5): p. 287-293.
17. Zhang, W., et al., Omega-3 polyunsaturated fatty acids in the brain: metabolism and neuroprotection. *Frontiers in bioscience (Landmark edition)*, 2010. 16: p. 2653-2670.
18. Ng, T.-P., et al., Tea consumption and cognitive impairment and decline in older Chinese adults. *The American journal of clinical nutrition*, 2008. 88(1): p. 224-231.
19. Kuriyama, S., et al., Green tea consumption and cognitive function: a cross-sectional study from the Tsurugaya Project. *The American journal of clinical nutrition*, 2006. 83(2): p. 355-361.
20. Schaefer, E.J., et al., Plasma phosphatidylcholine docosahexaenoic acid content and risk of dementia and Alzheimer disease: the Framingham Heart Study. *Archives of neurology*, 2006. 63(11): p. 1545-1550.
21. Morris, M.C., et al., Fish consumption and cognitive decline with age in a large community study. *Archives of neurology*, 2005. 62(12): p. 1849-1853.
22. van Gelder, B.M., et al., Fish consumption, n-3 fatty acids, and subsequent 5-y cognitive decline in elderly men: the Zutphen Elderly Study. *The American journal of clinical nutrition*, 2007. 85(4): p. 1142-1147.
23. He, K., et al., Fish consumption and risk of stroke in men. *Jama*, 2002. 288(24): p. 3130-3136.
24. Arab, L., W. Liu, and D. Elshoff, Green and black tea consumption and risk of stroke. *Stroke*, 2009. 40(5): p. 1786-1792.
25. Kokubo, Y., et al., The impact of green tea and coffee consumption on the reduced risk of stroke incidence in Japanese population. *Stroke*, 2013. 44(5): p. 1369-1374.
26. Noguchi-Shinohara, M., et al., Consumption of green tea, but not black tea or coffee, is associated with reduced risk of cognitive decline. *PLoS One*, 2014. 9(5): p. e96013.
27. Petrusdotir, A.L., et al., Effect of dietary n-3 polyunsaturated fatty acids on brain lipid fatty acid composition, learning ability, and memory of senescence-accelerated mouse. *The Journals of Gerontology Series A: Biological Sciences and Medical Sciences*, 2008. 63(11): p. 1153-1160.
28. Ehrnhoefer, D.E., et al., Green tea (-)-epigallocatechin-gallate modulates early events in huntingtin misfolding and reduces toxicity in Huntington's disease models. *Human molecular genetics*, 2006. 15(18): p. 2743-2751.
29. Bastianetto, S., et al., Neuroprotective effects of green and black teas and their catechin gallate esters against β -amyloid-induced toxicity. *European Journal of Neuroscience*, 2006. 23(1): p. 55-64.
30. Zhang, G., et al., Panax ginseng ginsenoside-Rg 2 protects memory impairment via anti-apoptosis in a rat model with vascular dementia. *Journal of ethnopharmacology*, 2008. 115(3): p. 441-448.
31. Eckert, G.P., Traditional used plants against cognitive decline and Alzheimer disease. *Frontiers in pharmacology*, 2010. 1: p. 138.
32. Heo, J.H., et al., An open-label trial of Korean red ginseng as an adjuvant treatment for cognitive impairment in patients with Alzheimer's disease. *European Journal of Neurology*, 2008. 15(8): p. 865-868.
33. Ahmed, T., et al., Ginsenoside Rb1 as a neuroprotective agent: A review. *Brain research bulletin*, 2016. 125: p. 30-43.
34. Yurko-Mauro, K., et al., Beneficial effects of docosahexaenoic acid on cognition in age-related cognitive decline. *Alzheimer's & Dementia*, 2010. 6(6): p. 456-464.
35. Bauer, I., et al., Omega-3 supplementation improves cognition and modifies brain activation in young adults. *Human Psychopharmacology: Clinical and Experimental*, 2014. 29(2): p. 133-144.
36. Boespflug, E., et al., Fish oil supplementation increases event-related posterior cingulate activation in older adults with subjective memory impairment. *The journal of nutrition, health & aging*, 2016. 20(2): p. 161.
37. Feng, L., et al., Tea Consumption Reduces the Incidence of Neurocognitive Disorders: Findings from the Singapore Longitudinal Aging Study. *J Nutr Health Aging*, 2016. 20(10): p. 1002-1009.
38. Pan, C.-W., et al., Tea consumption and health-related quality of life in older adults. *The journal of nutrition, health & aging*, 2017. 21(5): p. 480-486.
39. Park, S.-K., et al., A combination of green tea extract and l-theanine improves memory and attention in subjects with mild cognitive impairment: a double-blind placebo-controlled study. *Journal of medicinal food*, 2011. 14(4): p. 334-343.
40. Schmidt, A., et al., Green tea extract enhances parieto-frontal connectivity during working memory processing. *Psychopharmacology*, 2014. 231(19): p. 3879-3888.
41. Geng, J., et al., Ginseng for cognition. *The Cochrane Library*, 2010.
42. Shergis, J.L., et al., Panax ginseng in randomised controlled trials: a systematic review. *Phytotherapy Research*, 2013. 27(7): p. 949-965.
43. Lee, M.S., et al., Ginseng for cognitive function in Alzheimer's disease: a systematic review. *Journal of Alzheimer's Disease*, 2009. 18(2): p. 339-344.
44. Fotuhi, M., P. Mohassel, and K. Yaffe, Fish consumption, long-chain omega-3 fatty acids and risk of cognitive decline or Alzheimer disease: a complex association. *Nature Clinical Practice Neurology*, 2009. 5(3): p. 140-152.
45. Dangour, A.D., et al., Omega 3 fatty acids and cognitive health in older people. *British Journal of Nutrition*, 2012. 107(S2): p. S152-S158.
46. Bos, D.J., et al., Effects of omega-3 polyunsaturated fatty acids on human brain morphology and function: What is the evidence? *European Neuropsychopharmacology*, 2016. 26(3): p. 546-561.
47. Bolling, B.W., C.-Y.O. Chen, and J.B. Blumberg, Tea and health: preventive and therapeutic usefulness in the elderly? *Current opinion in clinical nutrition and metabolic care*, 2009. 12(1): p. 42.
48. Feng, L., et al., Pharmacokinetics, tissue distribution, metabolism, and excretion of ginsenoside Rg1 in rats. *Archives of pharmacological research*, 2010. 33(12): p. 1975-1984.
49. Stough, C., et al., Neuropsychological changes after 30-day Ginkgo biloba administration in healthy participants. *The International Journal of Neuropsychopharmacology*, 2001. 4(2): p. 131-134.
50. Akhondzadeh, S., et al., Passionflower in the treatment of generalized anxiety: A pilot double-blind randomized controlled trial with oxazepam. *Journal of clinical pharmacy and therapeutics*, 2001. 26(5): p. 363-367.
51. Bourin, M., et al., A combination of plant extracts in the treatment of outpatients with adjustment disorder with anxious mood: controlled study versus placebo. *Fundamental & clinical pharmacology*, 1997. 11(2): p. 127-132.
52. Malsch, U. and M. Kieser, Efficacy of kava-kava in the treatment of non-psychotic anxiety, following pretreatment with benzodiazepines. *Psychopharmacology*, 2001. 157(3): p. 277-283.
53. Connor, K. and J. Davidson, A placebo-controlled study of Kava kava in generalized anxiety disorder. *International clinical psychopharmacology*, 2002. 17(4): p. 185-188.
54. Gastpar, M. and H. Klimm, Treatment of anxiety, tension and restlessness states with Kava special extract WS® 1490 in general practice: A randomized placebo-controlled double-blind multicenter trial. *Phytomedicine*, 2003. 10(8): p. 631-639.
55. Jacobs, B.P., et al., An internet-based randomized, placebo-controlled trial of kava and valerian for anxiety and insomnia. *Medicine*, 2005. 84(4): p. 197-207.
56. Sarris, J., et al., The Kava Anxiety Depression Spectrum Study (KADSS): a randomized, placebo-controlled crossover trial using an aqueous extract of Piper methysticum. *Psychopharmacology*, 2009. 205(3): p. 399-407.
57. Sarris, J., et al., St. John's wort and Kava in treating major depressive disorder with comorbid anxiety: a randomised double-blind placebo-controlled pilot trial. *Human Psychopharmacology: Clinical and Experimental*, 2009. 24(1): p. 41-48.
58. File, S.E., et al., Cognitive improvement after 6 weeks of soy supplements in postmenopausal women is limited to frontal lobe function. *Menopause*, 2005. 12(2): p. 193-201.
59. Elsabagh, S., D.E. Hartley, and S.E. File, Limited cognitive benefits in Stage+ 2 postmenopausal women after 6 weeks of treatment with Ginkgo biloba. *Journal of Psychopharmacology*, 2005. 19(2): p. 173-181.

A COMBINATION OF ESSENTIAL FATTY ACIDS, PANAX GINSENG EXTRACT, AND GREEN TEA CATECHINS

60. Cao, J., et al., Incorporation and clearance of omega-3 fatty acids in erythrocyte membranes and plasma phospholipids. *Clinical chemistry*, 2006. 52(12): p. 2265-2272.
61. Fung, S.-T., et al., Comparison of catechin profiles in human plasma and urine after single dosing and regular intake of green tea (*Camellia sinensis*). *British Journal of Nutrition*, 2013. 109(12): p. 2199-2207.
62. Reay, J.L., A.B. Scholey, and D.O. Kennedy, Panax ginseng (G115) improves aspects of working memory performance and subjective ratings of calmness in healthy young adults. *Human Psychopharmacology: Clinical and Experimental*, 2010. 25(6): p. 462-471.
63. Folstein, M.F., S.E. Folstein, and P.R. McHugh, «Mini-mental state». A practical method for grading the cognitive state of patients for the clinician. *J Psychiatr Res*, 1975. 12(3): p. 189-98.
64. Wechsler, D., WAIS-R manual: Wechsler adult intelligence scale-revised. 1981: Psychological Corporation.
65. Lamers, M.J., A. Roelofs, and I.M. Rabeling-Keus, Selective attention and response set in the Stroop task. *Memory & Cognition*, 2010. 38(7): p. 893-904.
66. Lezak, M.D., Neuropsychological assessment. 2004: Oxford University Press, USA.
67. Glover, G.H., T.Q. Li, and D. Ress, Image-based method for retrospective correction of physiological motion effects in fMRI: RETROICOR. *Magnetic Resonance in Medicine*, 2000. 44(1): p. 162-167.
68. Gold, B.T., et al., Lifelong bilingualism maintains neural efficiency for cognitive control in aging. *Journal of Neuroscience*, 2013. 33(2): p. 387-396.
69. Hakun, J.G., et al., Evidence for reduced efficiency and successful compensation in older adults during task switching. *Cortex*, 2015. 64: p. 352-62.
70. Sohn, M.-H., et al., The role of prefrontal cortex and posterior parietal cortex in task switching. *Proceedings of the National Academy of Sciences*, 2000. 97(24): p. 13448-13453.
71. Dreher, J.-C., et al., The roles of timing and task order during task switching. *Neuroimage*, 2002. 17(1): p. 95-109.
72. Pearson, J.M., et al., Posterior cingulate cortex: adapting behavior to a changing world. *Trends in cognitive sciences*, 2011. 15(4): p. 143-151.
73. Yeung, N., et al., Between-task competition and cognitive control in task switching. *Journal of Neuroscience*, 2006. 26(5): p. 1429-1438.
74. Luft, A.R., et al., Repetitive bilateral arm training and motor cortex activation in chronic stroke: a randomized controlled trial. *Jama*, 2004. 292(15): p. 1853-1861.
75. Chiaravalloti, N.D., et al., Increased cerebral activation after behavioral treatment for memory deficits in MS. *Journal of neurology*, 2012. 259(7): p. 1337-1346.
76. Rushworth, M., et al., Role of the human medial frontal cortex in task switching: a combined fMRI and TMS study. *Journal of neurophysiology*, 2002. 87(5): p. 2577-2592.
77. Rissman, J., A. Gazzaley, and M. D'Esposito, Measuring functional connectivity during distinct stages of a cognitive task. *Neuroimage*, 2004. 23(2): p. 752-63.
78. Biswal, B.B., et al., Toward discovery science of human brain function. *Proc Natl Acad Sci U S A*, 2010. 107(10): p. 4734-9.
79. Fox, M.D., et al., The human brain is intrinsically organized into dynamic, anticorrelated functional networks. *Proceedings of the National Academy of Sciences of the United States of America*, 2005. 102(27): p. 9673-9678.
80. Sridharan, D., D.J. Levitin, and V. Menon, A critical role for the right fronto-insular cortex in switching between central-executive and default-mode networks. *Proceedings of the National Academy of Sciences*, 2008. 105(34): p. 12569-12574.
81. Goulden, N., et al., The salience network is responsible for switching between the default mode network and the central executive network: replication from DCM. *Neuroimage*, 2014. 99: p. 180-190.
82. Greicius, M., Resting-state functional connectivity in neuropsychiatric disorders. *Current Opinion in Neurology*, 2008. 21(4): p. 424-430.
83. Greicius, M.D., et al., Default-mode network activity distinguishes Alzheimer's disease from healthy aging: evidence from functional MRI. *Proc Natl Acad Sci U S A*, 2004. 101(13): p. 4637-42.
84. He, J., et al., Influence of functional connectivity and structural MRI measures on episodic memory. *Neurobiol Aging*, 2012. 33(11): p. 2612-2620.
85. Seeley, W.W., et al., Neurodegenerative diseases target large-scale human brain networks. *Neuron*, 2009. 62(1): p. 42-52.
86. Daniels, J.K., et al., Switching between executive and default mode networks in posttraumatic stress disorder: alterations in functional connectivity. *Journal of psychiatry & neuroscience: JPN*, 2010. 35(4): p. 258.
87. Whitfield-Gabrieli, S. and J.M. Ford, Default mode network activity and connectivity in psychopathology. *Annual review of clinical psychology*, 2012. 8: p. 49-76.
88. Utevsky, A.V., D.V. Smith, and S.A. Huettel, Precuneus is a functional core of the default-mode network. *Journal of Neuroscience*, 2014. 34(3): p. 932-940.
89. Tsukada, H., et al., Docosahexaenoic acid (DHA) improves the age-related impairment of the coupling mechanism between neuronal activation and functional cerebral blood flow response: a PET study in conscious monkeys. *Brain research*, 2000. 862(1): p. 180-186.
90. Wurtman, R.J., Synapse formation and cognitive brain development: effect of docosahexaenoic acid and other dietary constituents. *Metabolism*, 2008. 57: p. S6-S10.
91. Tassoni, D., et al., The role of eicosanoids in the brain. *Asia Pacific journal of clinical nutrition*, 2008. 17(S1): p. 220-228.
92. Dyall, S.C., Long-chain omega-3 fatty acids and the brain: a review of the independent and shared effects of EPA, DPA and DHA. *Frontiers in aging neuroscience*, 2015. 7.
93. Mandel, S. and M.B. Youdim, Catechin polyphenols: neurodegeneration and neuroprotection in neurodegenerative diseases. *Free Radical Biology and Medicine*, 2004. 37(3): p. 304-317.
94. Mandel, S.A., et al., Simultaneous manipulation of multiple brain targets by green tea catechins: a potential neuroprotective strategy for Alzheimer and Parkinson diseases. *CNS neuroscience & therapeutics*, 2008. 14(4): p. 352-365.
95. Radad, K., R. Moldzio, and W.D. Rausch, Ginsenosides and their CNS targets. *CNS neuroscience & therapeutics*, 2011. 17(6): p. 761-768.
96. Kim, H.J., P. Kim, and C.Y. Shin, A comprehensive review of the therapeutic and pharmacological effects of ginseng and ginsenosides in central nervous system. *Journal of ginseng research*, 2013. 37(1): p. 8.
97. Sperling, R.A., et al., Toward defining the preclinical stages of Alzheimer's disease: Recommendations from the National Institute on Aging-Alzheimer's Association workgroups on diagnostic guidelines for Alzheimer's disease. *Alzheimer's & Dementia*, 2011. 7(3): p. 280-292.
98. Jack, C.R., et al., Tracking pathophysiological processes in Alzheimer's disease: an updated hypothetical model of dynamic biomarkers. *The Lancet Neurology*, 2013. 12(2): p. 207-216.
99. Villemagne, V.L., et al., Amyloid β deposition, neurodegeneration, and cognitive decline in sporadic Alzheimer's disease: a prospective cohort study. *The Lancet Neurology*, 2013. 12(4): p. 357-367.
100. Eklund, A., T.E. Nichols, and H. Knutsson, Cluster failure: Why fMRI inferences for spatial extent have inflated false-positive rates. *Proceedings of the National Academy of Sciences of the United States of America*, 2016. 113(28): p. 7900-7905.