

HOSTED BY



Contents lists available at ScienceDirect

International Journal of Nursing Sciences

journal homepage: <http://www.elsevier.com/journals/international-journal-of-nursing-sciences/2352-0132>

Original Article

Reliability and validity of the Chinese version of the new fear of hypoglycemia scale: FH-15

Ya-Qian Liu^a, Si-Qi Xiong^a, Ming Sang^a, Yu-Feng Li^a, María Teresa Anarte Ortiz^b, Qiu-Ling Xing^c, Hong-Mei Xu^c, Chang-De Jin^{d,*}^a Department of Graduate, Tianjin University of Traditional Chinese Medicine, Tianjin, China^b University of Malaga, Spain^c The Ministry of Health Key Laboratory of Hormone and Development, Metabolic Disease Hospital of Tianjin Medical University, China^d Department of Nursing, Tianjin University of Traditional Chinese Medicine, Tianjin, China

ARTICLE INFO

Article history:

Received 6 May 2018

Received in revised form

8 September 2018

Accepted 17 September 2018

Available online 21 September 2018

Keywords:

Diabetes mellitus

Type 2

Fear

Hypoglycemia

Reliability

Validity

ABSTRACT

Objective: This study aimed to evaluate the reliability and validity of the Chinese version of the Fear of Hypoglycemia scale with 15 items (FH-15).**Methods:** After obtaining the original author's authorization, the English version of the FH-15 scale was translated, back translated, and culturally debugged to obtain the Chinese version of FH-15. A convenient sampling method was used to extract patients with type 2 diabetes from four tertiary hospitals in Tianjin. A total of 408 patients with type 2 diabetes were investigated in the hospital to test the reliability and validity of Chinese version FH-15 scale.**Results:** The content validity index of the scale was 0.92, and the content validity index of each item was 0.8–1.0. The exploratory factor analysis extracted three common factors (fear, avoidance, and interference), which contained 15 items, and the cumulative variance contribution rate was 71.245%. The confirmatory factor analysis results showed that the model fit was better at 1.981 χ^2/df , GFI = 0.901, CGI = 0.962, TLI = 0.952, and RMSEA = 0.070. The cut-off value for the total hypoglycemia fear scale was 30.5. The Cronbach's α coefficient of the three dimensions of the scale was 0.918, the Cronbach's α coefficient of each dimension is 0.876–0.916, the test–retest reliability was 0.903, and the test–retest reliability of each factor was 0.733–0.930.**Conclusion:** The Chinese version of the FH-15 scale can be considered reliable and valid. The item expression is concise, clear, and easy to understand. It is suitable for clinical practice as an initial screening tool to identify and evaluate the severity of fear of hypoglycemia in patients with type 2 diabetes.© 2018 Chinese Nursing Association. Production and hosting by Elsevier B.V. This is an open access article under the CC BY-NC-ND license (<http://creativecommons.org/licenses/by-nc-nd/4.0/>).

1. Introduction

Diabetes is a chronic disease, in which patients should control their blood glucose levels within normal levels. Patients with diabetes mellitus (DM) need to monitor blood glucose level several times a day [1]. At present, strict methods for controlling blood glucose include the early use of insulin and intensive hypoglycemic therapy [2]. Hypoglycemia is the most common adverse event

associated with insulin therapy for diabetes. It may lead to fear of hypoglycemia (FH) in patients with DM because of physical discomfort and potential life threats [3]. Hypoglycemia has affected 68.4% of elderly patients with type 2 diabetes mellitus (T2DM). In addition, patients with diabetes with multiple episodes of hypoglycemia have significantly increased their FH. The experience of more than three episodes of hypoglycemia is associated with a 13-fold higher risk of FH [4].

FH is a variety of distasteful symptoms, emotions, cognition, and adverse physical and social consequences caused by hypoglycemia [5]. It also causes diabetes patients to adopt fearful and avoidance behaviors related to hypoglycemia [5]. A recent cross-sectional survey of diabetics in nine countries, by Panorama, showed that nearly half of diabetics with history of low blood sugar has suffered

* Corresponding author. Jing Hai District Health Industry Park, 301617, Department of Nursing, Tianjin University of Traditional Chinese Medicine, Tianjin, China.
E-mail addresses: yaqian0724@126.com (Y.-Q. Liu), jcd1886@sina.cn, 853245087@qq.com (C.-D. Jin).

Peer review under responsibility of Chinese Nursing Association.

from fear of the recurrence of hypoglycemia [6]. This tension and anxiety not only aggravated the patient's fear of disease control, but also seriously affected their blood glucose management behavior and quality of life [7].

FH is easily confused with other symptoms of hypoglycemia and clinically lacks tools with well-defined thresholds, thereby increasing the risk of hypoglycemia and is not conducive to self-management of patients with diabetes [8]. Therefore, effective and accurate identification of FH is a prerequisite for improving the health management of patients with type 2 diabetes.

A review of domestic and foreign literature found that the widely used hypoglycemia fear assessment tool is the Hypoglycemia Fear Survey (HFS) compiled by Professor Cox in 1987 and revised in 1998. This scale has 33 items, including behavioral scales and worry scale. However, the scale not only has many entries, but also lacks clear cutoff value. Moreover, a research found that the internal equity of the behavior subscale is low and has no subjective interpretation related to behavior [9–11]. To this end, Anarte et al. developed the FH-15 scale in 2011 [12]. The scale is suitable for patients with type 1 and type 2 diabetes (especially with insulin). The entry is streamlined and easy to understand, with a clear cutoff value, good reliability and validity. The FH-15 scale can help clinicians rapidly and accurately identify FH and its severity. Subsequently, the scale was applied in the country for investigations and retrospective studies, which are simple and effective tools for evaluating FH in diabetic patients [13,14].

This study aimed to verify the reliability and validity of Chinese version of FH-15 scale, which can provide an effective tool for accurate screening and rapid assessment of hypoglycemia in patients with type 2 diabetes.

2. Methods

2.1. Study design and setting

The study included two parts. The first part aims to translate and modify FH-15. The second part aims to test the reliability and validity of the Chinese version.

The study was carried out in four hospitals in Tianjin, including Tianjin Medical University Metabolic Disease Hospital, Tianjin First Central Hospital, Tianjin Fourth Central Hospital, and Tianjin Jixian People's Hospital. The sample size was estimated according to the principle that the surveyed number was 10–20 times the number of items [15]. Then, 20% invalid questionnaires were added. Thus, the total sample size was approximately 180. The inclusion criterion was as follows: (1) ≥ 18 years, who are alert and able to participate according to the judgment; (2) conforms to WHO's T2DM diagnostic criteria, with a clear diagnosis of type 2 diabetes; (3) patients who have experienced hypoglycemia in the past according to the American Diabetes Association (ADA) criteria [16]. Patients who met the following criteria were excluded: (1) with mental illness or cognitive dysfunction; (2) with complications and have taken antipsychotic drugs in the past two years.

2.2. Research tool

2.2.1. Demographic and clinical data

The demographic data includes age, gender, occupation, educational level, marital status, accommodations, and family income. The clinical data includes medical treatment, family history of diabetes, course of disease, treatment plan, and fluctuations in blood glucose.

2.2.2. FH-15 scale

This scale was developed by Prof. Anarte [12] of Spain in 2011. It

was created by a questionnaire survey, a structured interview, and a closed question called subjective FH. This scale has 15 items, using 5-point Likert scale: 1 = never; 2 = hardly; 3 = sometimes; 4 = almost always; 5 = every day. The scoring range is 15–75 points. The total score of more than 28 indicates that the patients suffered from FH. This scale contains three dimensions, namely, fear, avoidance, and interference. The Cronbach's α coefficient of each dimension is above 0.75, which can explain the variation of 58.27%. The Cronbach's α coefficient of the scale was 0.891, and the retest reliability was 0.908.

2.2.3. Subjective fear question

The subjective cognition of the patients' FH is evaluated by a closed question to follow the consistency principle of the development of the original scale [16]. The question was raised in writing with the FH-15 questionnaire. The question is as follows: "Are you afraid of hypoglycemia?" The answer option is "yes" or "no" [12].

2.2.4. Chinese version of Hypoglycemia Fear Survey II-Worry Scale

Professor Cox, who was from the university of California health sciences center, revised the hypoglycemic fear scale and formulated the Hypoglycemia Fear Survey II in 2011. The scale was used to measure the degree of concern about hypoglycemia in patients with diabetes in the past six months [17]. In 2015, Mu et al. [18] translated the Hypoglycemia Fear Survey II-Worry Scale into Chinese and applied it to patients with type 2 diabetes with hypoglycemia within six months. The Chinese version of Hypoglycemia Fear Survey II-Worry Scale (CHFSII-WS) contains 13 items including two dimensions of worry and embarrassment. It uses 5-point Likert scale (0–4) and scores range from 0 to 52 points. The degree of FH of diabetic patients is greater when the score is higher. The Cronbach's α coefficient of the scale was 0.904, and the retest reliability was 0.911.

2.3. Research process

The researchers obtained consent and authorization to use the scale from Prof. Anarte. The Functional Assessment of Chronic Illness Therapy (FACIT) [19] was adopted to facilitate the sinicization of FH-15 scale. The specific steps are as follows. (1) Forward-translated: two bilingual researchers, including an Australian Chinese clinical staff major in diabetes and a researcher, who is familiar with Chinese and English, translated the English version into the Chinese version. (2) Proofreading: the result was checked by a diabetes expert with seven years of foreign clinical experience, and formed the first translation. (3) Back-translated: two English experts, who didn't know the research content, were invited to translate the first translation back into English and form a back-translation scale. Then, it was sent to the original author. The back-translation scale was compared with the original scale, the semantics was analyzed, and the original author's comments were integrated to revise the content of the Chinese version until the Chinese and the original versions reach the same definition, content, and semantics. (4) Cultural adaptation: the debugging principles of the self-report scale cross-cultural debugging guide were followed [20], and the most appropriate Chinese language expression was selected according to the language characteristics of the Chinese people. Cultural adjustments were conducted for the content that does not satisfy Chinese habits and are difficult to understand, and the second translation was formed. (5) Scale content reliability evaluation: five experts with more than 10 years of working experience in this field were invited to evaluate the content validity of the scale. The content validity evaluation form was handed over to the experts by the researcher, in a paper version, and reviewed in a timely manner. (6) Pre-experiment: 10

subjects were selected for pre-experiment to test whether the scale had semantically ambiguous and incomprehensible entries. The patient's opinions were revised to form the Chinese version of FH-15 scale.

2.4. Data collection

This study was conducted under the approval of the Hospital's Medical Ethics Committee and the support of the relevant department leaders. A convenient sampling method was used to select patients with type 2 diabetes, who were admitted to the endocrinology department of four tertiary hospitals in Tianjin. The researchers introduced the purpose, significance, confidentiality principles, and questionnaires to the patients in the unified guidance language. After obtaining the informed consent of the patient, the researcher personally distributed the questionnaire. All the questionnaires were anonymously filled in and retracted on site. The researchers checked for any missing items or items not responded in the questionnaire on the spot and timely communicated with the patients. If the patient could not complete by himself due to limited education, the researcher assisted him/her in completing the questionnaire. In addition, 30 patients were randomly selected from the sample to fill in the Chinese version of FH-15 scale after two weeks. The patient was invited, using the contact information in the first survey, to make an appointment in advance and fill out the questionnaire by telephone. When conducting the test–retest reliability, the patients are asked if a major stress event occurred within two weeks. The same testers, test procedures, and measurement time and similar surroundings were maintained. A total of 450 questionnaires were issued, and 408 valid questionnaires were retrieved by removing invalid data such as missing data and duplicate entries. The effective recovery rate was 90.7%.

2.5. Data analysis

2.5.1. Statistical method

The method of double entry was used to enter the data to ensure accuracy and completeness. Data were analyzed using the Statistical Package for Social Science (SPSS) version 17.0 for windows, and AMOS 21.0 software was used to generate random sequences, which include the exploratory factor analysis (EFA) group and confirmatory factor analysis (CFA) group. Descriptive analysis was used to evaluate the demographic and clinical data. The psychometric properties of the Chinese FH-15 scale were reflected by validity and reliability. The counting data were described by frequency and percentage, and the measurement data were described using mean or standard deviation.

2.5.2. Validity and reliability

The content validity was evaluated by using the item content validity index (I-CVI) and the average content validity index (S-CVI/Ave) of the total item. The criterion-related validity was examined by evaluating the correlation coefficient (Person relation analysis) between the scores of the FH-15 scale and the CHFSII-WS scale. The structural validity was analyzed by exploratory factor analysis and confirmatory factor analysis. Pearson correlation analysis and some diagnostic test indexes, such as false positive percentage, false negative percentage, positive predictive value, and negative predictive value, were adopted. The EFA group underwent exploratory factor analysis using SPSS 17.0 software. KMO and Bartlett ball inspection were conducted to determine suitability for factor analysis using principal component analysis and maximum variance orthogonal rotation method to extract the characteristic value, which is greater than one common factor. The CFA group with

AMOS 21.0 software used confirmatory factor analysis of structural equation model, chi-square of goodness of fit (χ^2) and the ratio of degrees of freedom (χ^2/df), goodness of fit index (GFI), fit index (CFI), and approximation error root mean square (RMSEA) such as goodness-of-fit index to evaluate the model. The optimal critical point was determined according to the Youden index using the SPSS software to draw the ROC curve [21], and the low blood glucose fear cut-off value of the FH-15 scale was finally obtained.

Cronbach's α coefficient and test–retest reliability were used to evaluate the reliability of the scale. The Cronbach's α value of the entire scale and the three dimensions were measured. Test–retest reliability was also assessed. Thirty participants were randomly selected from the sample, and they were re-evaluated after four weeks. The data were analyzed by Pearson relation analysis for test–retest reliability. The test–retest reliability was acceptable when the correlation coefficient was higher than 0.75 [32].

3. Results

3.1. Demographic and clinical data (Table 1)

A total of 408 patients of type 2 diabetes were surveyed, including 240 males and 168 females, and the proportion of patients older than 60 was 43.1%. The duration of diabetes in most patients is less than 10 years (80.9%), and the educational level is mostly junior high school (31.1%), high school, or secondary school (31.6%). A total of 50% of the patients had little knowledge of hypoglycemia prevention and treatment, and most of the patients had mild hypoglycemia (60.8%).

3.2. Item analysis

The total score of hypoglycemia of the 408 subjects included in the study was ranked. Twenty-seven percent of observations before and after the subjects' scores was considered the cut-off point, and the data were divided into 1 = high group and 2 = low group. Independent sample *t*-test was used to analyze the differences between the two groups in each item, and the items with poor discriminability were deleted according to the statistical standard (the critical ratio, $CR < 3$). Meanwhile, the average difference between the high and low groups was evaluated by observing the 95% confidence interval for each item's difference. If it does not contain 0, then the difference between the two groups in each item is statistically significant. In addition, the correlation coefficient (*r*-value) of each item and the total scale were obtained by the product–difference correlation coefficient method to analyze the homogeneity. If the value of *r* is < 0.3 , then the item is less relevant to the scale and should be considered for deletion. The results showed that the CR value of each item was 6.572–15.668. The difference between the two groups was statistically significant ($P < 0.000$), and the 95% confidence intervals did not contain 0, thereby indicating that each item had higher degree of discrimination. A correlation coefficient existed between each item, and the total score was 0.485–0.797 ($P < 0.01$), indicating a good correlation; thus, all items can be retained (Table 2).

3.3. Content validity

Five experts were invited to evaluate the content validity of the Chinese version of the FH-15 scale. The entries were scored according to the relevance of each item to the content measured by the scale, using a Likert 4-grade score of 0–4 (from “not relevant” to “very relevant”). The cumulative frequency of 3 or 4 points in the expert score for each item is divided by the total frequency, based on the scores from experts, to calculate the I-CVI for all items. Then

Table 1
Demographic characteristics.

Variables		EFA (n = 204)		CFA (n = 204)	
		n	%	n	%
Age (years)	≤44	30	14.7	39	19.1
	45–59	77	37.7	77	37.7
	>60	97	47.5	88	43.1
Sex	Male	129	63.2	111	54.4
	Female	75	36.8	93	45.6
Occupation	Stable work	49	24.0	49	24.0
	Unstable work	34	16.7	30	14.7
	Retired	53	26.0	53	26.0
	Unemployed	21	10.3	26	12.7
	Others	47	23.0	46	22.5
Educational level	Primary school or below	46	22.5	49	24.0
	Junior high school	65	31.9	62	30.4
	High school or secondary	65	31.9	64	31.4
	College and above	28	13.7	29	14.2
Marital status	Unmarried	3	1.5	2	1.0
	Married	185	90.7	189	92.6
	Divorced	2	1.0	2	1.0
	Widowed	14	6.9	11	5.4
Accommodations	Alone	13	6.4	6	2.9
	With family	191	93.6	198	97.1
Monthly Family income (Yuan)	≤2000	20	9.8	29	14.2
	2001–3000	27	13.2	29	14.2
	3001–5000	75	36.8	86	42.2
	>5000	82	40.2	60	29.4
Medical insurance	For resident	112	54.9	101	49.5
	For employees	80	39.2	85	41.7
	Self-paying	10	4.9	12	5.9
	Others	2	1.0	6	2.9
Family history of diabetes	No	100	49.0	107	52.5
	Yes	104	51.0	97	47.5
Duration of diabetes (years)	≤10	169	82.8	161	78.9
	11–19	27	13.2	37	18.1
	≥20	8	3.9	6	2.9
Therapy	Oral medications	97	47.5	101	49.5
	Insulin	24	11.1	22	10.8
	Boths	83	40.7	81	39.7
Glucose fluctuation	Small	62	30.4	64	31.4
	Moderate	36	17.6	45	22.1
	Large	106	52.0	95	46.6
Interval with glucose measurement (days)	≤1	106	52.0	115	56.4
	2–14	81	39.7	66	32.4
	Never	17	8.3	23	11.3
Social support	Less	29	14.2	20	9.8
	Moderate	98	48.0	4	46.1
	More	77	37.7	90	44.1
Knowledge of hypoglycemia prevention treatment	Poor	28	13.7	38	18.6
	A little	107	52.5	97	47.5
	More	65	31.9	67	32.8
	Good	4	2.0	2	1.0
Experience of hypoglycemia (times)	1–2	124	60.8	124	60.8
	3–6	68	33.3	62	30.4
	7–24	12	5.9	18	8.8
Severity of hypoglycemia	Mild	117	57.4	131	64.2
	Moderate	25	12.3	17	8.3
	Severe	56	27.5	40	19.6
	Extremely heavy	6	2.9	16	7.8
Awareness of hypoglycemia	Always	62	30.4	53	26.0
	Sometimes or not	142	69.6	151	74.0
Subjective fear of hypoglycemia	Yes	127	62.3	117	57.4
	No	77	37.7	87	42.6

the average was obtained to determine the S-CVI/Ave at the scale level. The sales level CVI (S-CVI) was obtained, according to the expert score, by calculating the ratio of the number of items with a score of 3 or 4 to the number of items. The number of experts with a score of 3 or 4 is divided by the total number of experts that evaluated the item level of each item CVI (I-SVI). The results showed that the I-CVI value of each item was 0.8–1.0 and the S-CVI/Ave was 0.92, thereby indicating that the scale had good reliability and validity (Table 3).

3.4. Construct validity

3.4.1. EFA

The EFA group performed KMO and Bartlett tests on 204 patients with T2DM and with hypoglycemia fear. The results showed that the KMO value was 0.895 > 0.5 and the Bartlett was 2169.916 ($P < 0.000$), indicating that the correlation between the variables was strong and thus was suitable for factor analysis. The principal component method and variance maximum orthogonal rotation

Table 2Factor load matrix after rotation of Chinese version FH-15 and the correlation coefficient between each item score and total score ($n = 204$).

Items	Factor loading			r value
	Factor 1	Factor 2	Factor 3	
5. How often are you afraid of having hypoglycemia while alone?	0.861	0.151	0.089	0.683
4. How often are you afraid of having hypoglycemia outside of a hospital/health care setting?	0.790	0.349	0.027	0.732
1. How often do you fear not recognizing the symptoms of hypoglycemia?	0.789	0.248	-0.128	0.602
3. How often are you afraid of having hypoglycemia at work?	0.751	0.334	-0.037	0.671
13. How often do you worry about losing consciousness due to hypoglycemia?	0.747	-0.193	0.271	0.485
14. How often are you afraid of falling asleep for fear of having hypoglycemia at night?	0.695	0.274	0.275	0.735
2. How often are you afraid of not knowing what to do in the event of hypoglycemia?	0.516	0.340	0.246	0.648
10. How often do you have hypoglycemia that interferes with your leisure activities?	0.162	0.828	0.303	0.757
11. How often do you have hypoglycemia that interferes with your family life?	0.152	0.806	0.227	0.706
8. How often do you have hypoglycemia that makes you unable to drive or use machinery?	0.269	0.768	0.326	0.797
9. How often do you have hypoglycemia that makes you unable to work?	0.357	0.759	0.205	0.789
12. How often do you have hypoglycemia that interferes with your social life?	0.253	0.696	0.368	0.760
15. How often are you afraid of taking a trip/holiday for fear of experiencing hypoglycemia?	0.105	0.324	0.863	0.685
6. How often do you avoid social situations (meetings, outings, etc.) due to fear of having a hypoglycemic episode?	0.103	0.327	0.855	0.656
7. How often do you stop doing things you used to do for fear of having a hypoglycemic episode?	0.044	0.251	0.740	0.526
Eigenvalue	7.069	2.472	1.147	
Accumulated variance contribution rate.(%)	27.961	53.330	71.245	

Note: $P < 0.01$ for all r values.

FH-15: 15-item fear of hypoglycemia scale; Factor 1: Fear; Factor 2: Interference; Factor 3: Avoidance.

Table 3Expert content validity evaluation form ($n = 5$).

Items	Scores					Number of 3 and 4 points	I-CVI	Result
	A	B	C	D	E			
1	4	4	4	3	4	5	1.00	Better
2	3	4	4	4	3	5	1.00	Better
3	4	4	3	2	4	4	0.80	Better
4	4	3	4	4	3	5	1.00	Better
5	4	2	3	4	4	4	0.80	Better

Note: $S-CVI/Ave = (1 + 1 + 0.8 + 1 + 0.8)/5 = 92.0\%$.

method were applied to 15 items, and the number of extracted factors was unlimited. Moreover, the common factor with feature value > 1 and the item with factor load ≥ 0.4 were reserved. The results showed that three common factors were extracted. The load of each factor was 0.516–0.863, and the characteristic values of each factor were 7.069, 2.472, and 1.147, explaining 27.961%, 25.369%, and 17.915% of the total variance of the original variables, respectively. The total cumulative variance contribution rate is 71.245%. The attribution dimension of each item in the Chinese version of FH-15 scale is consistent with the original scale. The gravel chart results are consistent with these findings (Table 2, Fig. 1).

3.4.2. Confirmatory factor analysis

AMOS software was used to construct structural equation modeling (SEM) of 204 cases of CFA data to further verify the construct validity of the scale. If the GFI of the SEM is greater than 0.8, then the CFI, TLI, and NFI are all greater than 0.9 and the RMSEA is less than 0.08, thereby indicating that the model is effective. The model fitting index results showed that χ^2/df was 1.981, GFI = 0.901, CGI = 0.962, TLI = 0.952, and RMSEA = 0.070. However, RMR and AGFI have not reached the best-fit index, but the other major indicators satisfied the requirements for model fitting (Fig. 2), thereby indicating that the fitness of the model, the data theory, and the structural validity were excellent.

3.5. Convergent validity

The correlation between WS scale and the Chinese version of FH-15 scale, in terms of dimensions, was analyzed. The scores were

mostly positively correlated ($P < 0.01$) (Table 4). In addition, the scores of the FH-15 scale were divided into fears and fearlessness based on the subjective fear questions. Significant differences were observed between the two groups ($t = 18.357$, $P < 0.000$). The specificity based on the scale was 0.704, the sensitivity was 0.839, the percentages of false negatives and false positives were 25.2% and 16.5%, respectively, the positive predictive value (PPV) was 86.7%, and the negative predictive value (NPV) was 70.3%. Both predictors were within acceptable ranges (Tables 5 and 6).

3.6. Reliability

The Cronbach's α coefficient of the Chinese version of FH-15 scale was 0.918, and the Cronbach's α coefficient of the three dimensions, namely, fear, avoidance, and interference were 0.891, 0.876, and 0.916, respectively. After a two-week interval, 30 patients with no major stress events within two weeks were randomly selected to re-issue the questionnaire. The test–retest reliability was 0.903. The test–retest reliability of each factor was 0.733–0.930.

3.7. Cutoff value and incidence

The patients with type 2 diabetes were screened for hypoglycemia, according to the subjective fear of the questionnaire. The non-parametric method was used to construct the ROC curve, and the point of contact with the largest Youden index was used as the critical point. The area under the curve (AUC) greater than 0.7 indicates good diagnostic value. The final cutoff value for FH was 30.5 points. At this time, the AUC was 0.816, the specificity was 0.704, and the sensitivity was 0.839. Thus, patients with type 2 diabetes suffer from FH when the FH score is more than 30.5 (Fig. 3). The prevalence of FH in the population was 65.7%, with subjective fear as the standard. The prevalence of FH was slightly lower (58.3%), according to the new FH-15 scale.

4. Discussion

4.1. Reliability and validity

The reliability and validity of the Chinese version of FH-15 scale were measured. The total Cronbach's α coefficient was 0.918, and

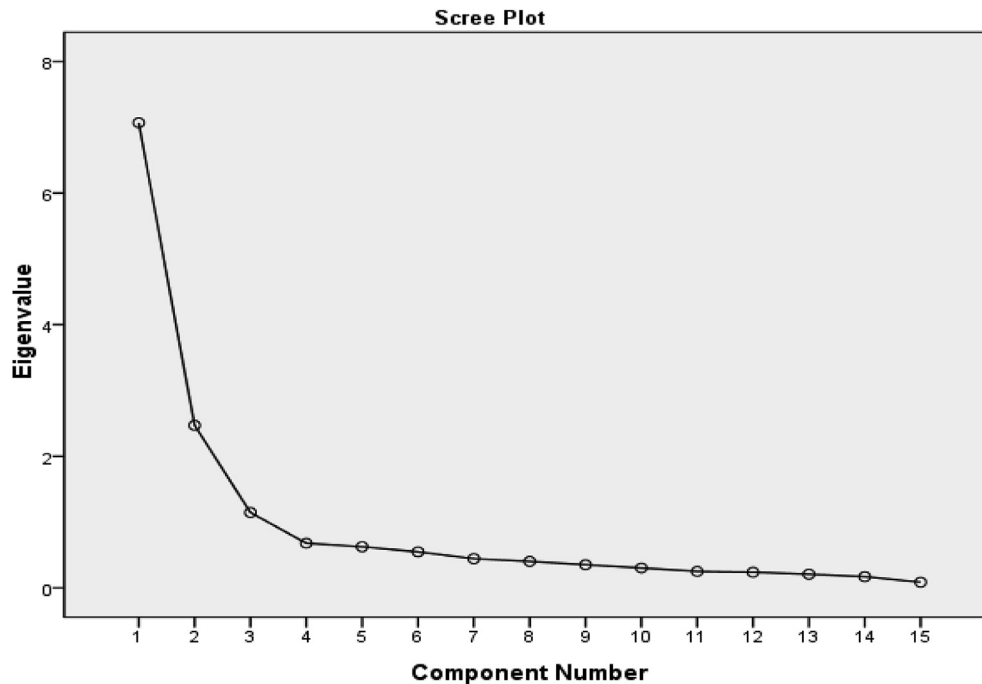

Fig. 1. A scree plot illustrating the factor loading of the Chinese version of FH-15 scale.

the retest reliability was 0.903. The scale of each CVI was greater than 0.90. The surface scale, reliability, and validity [22,23] can effectively measure FH in patients with type 2 diabetes. However, the test–retest reliability still has some shortcomings. The test–retest reliability of item 12 is less than 0.8 (0.733), which is slightly lower than that in the study of Schininà et al. [24]. The reasons for this result may be as follows: first, the outcome indicator of the study (i.e., FH) is unstable and susceptible to the surrounding environment [23]. Second, the psychological condition can be affected by behavioral factors to some extent [25–27]. At the time of retesting, the patient was basically discharged from the hospital. The patient may increase the amount of exercise and prepare food for himself to avoid hyperglycemia. This type of “cautious” behavior with changes in the social environment may lead to FH. Three components were extracted after EFA. Chinese FH-15 scores and WS scale score obtained a moderate positive correlation, and the PPV and NPV were within the acceptable range. The results showed that Chinese FH-15 scale has excellent convergent validity and can predict and diagnose FH in patients with diabetes.

4.2. Application prospect of Chinese version of FH-15 scale

In the process of controlling blood glucose in patients with type 2 diabetes, hypoglycemic events are a major obstacle to the treatment of diabetes [28]. If a patient witnesses hypoglycemia or a hypoglycemic episode, then he or she is very susceptible to hypoglycemia [29]. This fear not only causes patients to overcompensate to avoid the same risk of recurrence of hypoglycemia, but also leads to decreased patient compliance and self-management skills. Thus, this behavior will increase the incidence of long-term complications of diabetes and become an important factor hindering diabetes management [30]. At present, the most widely used low-blood glucose fear assessment tool in China is CHFSII-WS, which was tested by Mu et al. in patients with type 2 diabetes with hypoglycemia within six months. However, FH may also be present in patients, who have not previously experienced hypoglycemia [31].

Only patients with type 2 diabetes with experienced hypoglycemia in the past six months are suitable to apply the CHFSII-WS. This parameter may affect the widespread use of this Chinese version of the scale. In addition, the CHFSII-WS lacks a clear threshold, causing difficulty for clinical staff to determine clinically meaningful ranges of hypoglycemia fear scores. Therefore, they cannot timely and effectively deal with the mental disorders and behavioral changes of diabetic patients in hypoglycemia [3]. Therefore, timely detection and accurate screening of diabetic patients with hypoglycemic fear are important. Contrary to the FH-15 scale, which was localized in this study, a clear hypoglycemia fear threshold (FH \geq 30.5 is the hypoglycemia fear) was obtained. The scale can also effectively identify patients, who experienced fear but did not show fear symptoms. In summary, the Chinese version of the FH-15 scale can be used to screen for FH in patients with type 2 diabetes. Clinical staff should provide corresponding psychological or behavioral interventions to patients with a hypoglycemia fear score of \geq 30.5 to reduce FH for effective management of glycemic control.

However, some disadvantages still exist. Although this study adopts the convenience sampling method, the samples are all from the same city. Thus, the research results are affected by the region. Therefore, the universality of the scale should be further verified in multiple regions. In addition, the applicable population in the primary scale is type 2 (especially insulin therapy) and type 1 diabetes, but only type 2 diabetes patients were selected for validation in this study. Finally, the test has an item with a test–retest reliability of less than 0.8, indicating that the cross-time stability of the entry must be improved and the researchers must strictly control the environmental consistency of the two measurements to reduce the measurement error when conducting the test–retest reliability in the future research. Therefore, the breadth and depth of research objects must be expanded to further improve the study.

5. Conclusion

In summary, the Chinese version of FH-15 scale has good reliability and validity. The item expression is concise, clear, and easy to

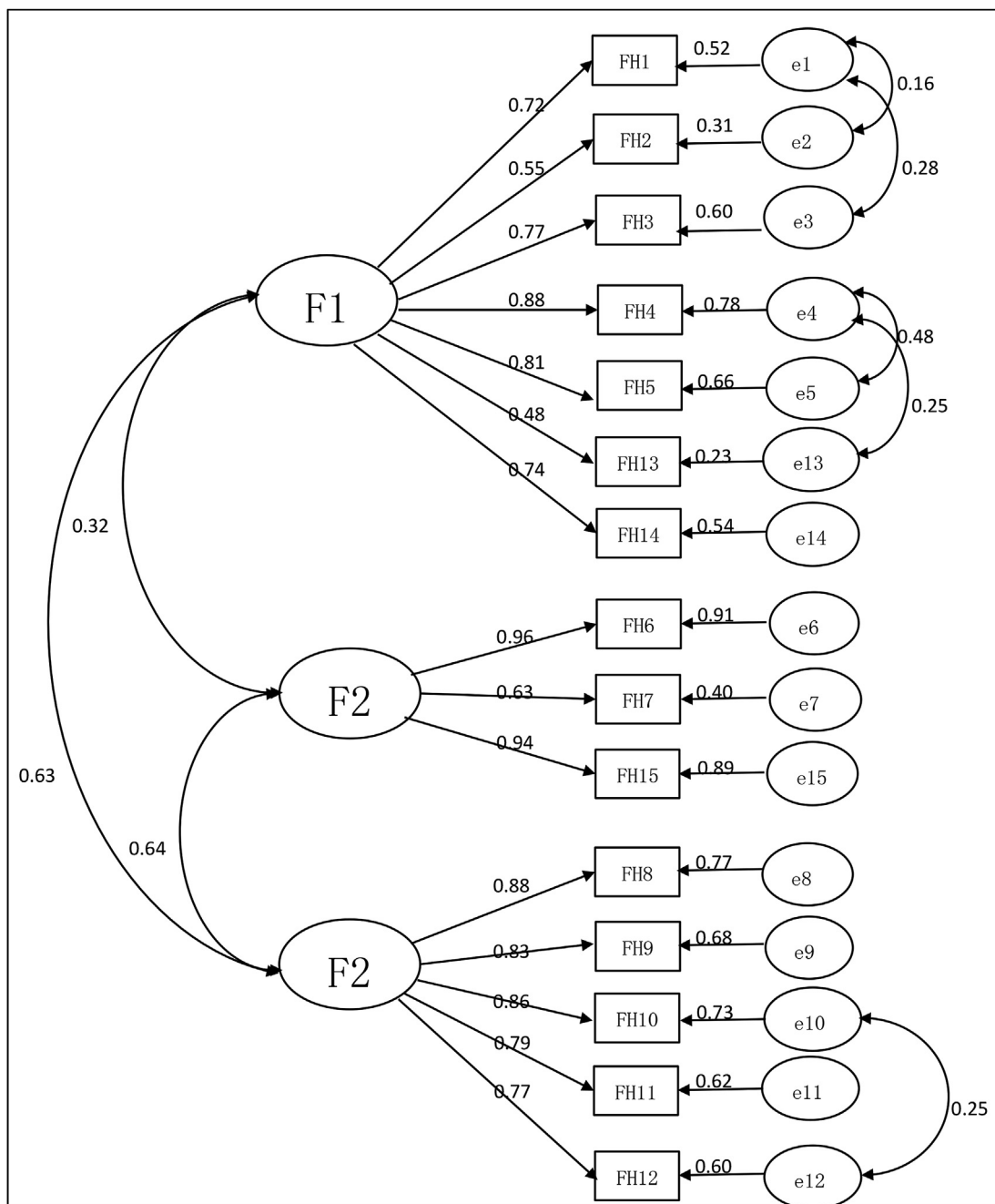

Fig. 2. Structural Equation Model of the Chinese Version of FH-15 scale.

Table 4
Correlation between the Chinese FH-15 dimensions and the CHFSII-WS.

Dimension	CHFSII-WS total	Worry and Fear	Embarrassment
FH-15 Total	0.578 ^a	0.540 ^a	0.286 ^a
Fear	0.442 ^a	0.393 ^a	0.281 ^a
Avoidance	0.464 ^a	0.461 ^a	0.141 ^b
Interference	0.519 ^a	0.492 ^a	0.236 ^a

Note: ^a $P < 0.01$; ^b $P < 0.05$. FH-15: 15-item fear of hypoglycemia scale. CHFSII-WS: Chinese version of Hypoglycemia Fear Survey II-Worry Scale.

Table 5
FH-15 scale score on subjective fears ($n = 204$).

FH-15	Subjective Fears			<i>t</i> value	<i>P</i> value
	Mean	SD	<i>n</i>		
Yes	40.20	7.815	119	18.357	<0.001
No	25.51	3.294	85		

Note: FH-15: 15-item fear of hypoglycemia scale.

understand. It can be used to screen and assess the severity of hypoglycemia fear in patients with type 2 diabetes. It provides

evidence for medical personnel to identify low blood sugar fears rapidly and implement psychological or behavioral guidance and interventions.

Table 6
Cutoff data of FH-15 scale.

FH-15 Total	Subjective Fears(<i>n</i>)		Total
	yes	no	
≥30.5	89	14	103
<30.5	30	71	101
Total	119	85	204

Note: FH-15: 15-item fear of hypoglycemia scale.

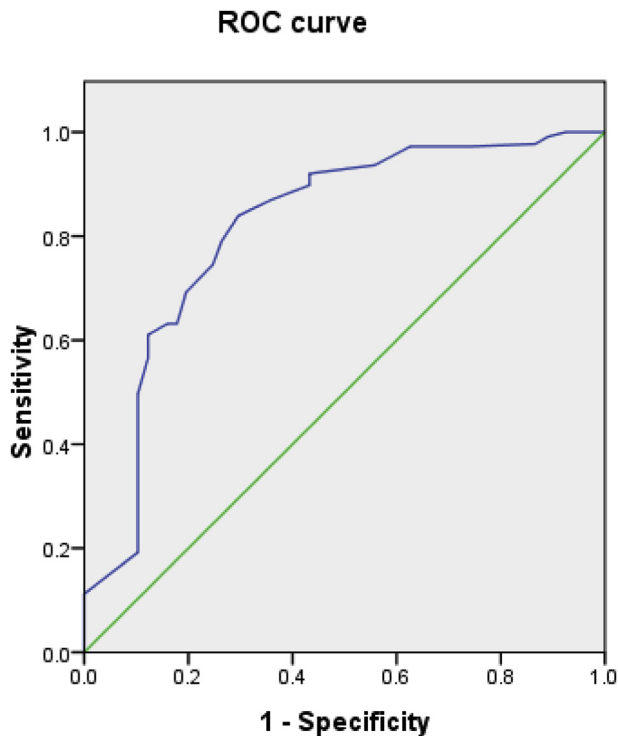

Fig. 3. ROC curve of the Chinese version of FH-15 scale.

Conflicts of interest

None declared.

Funding

None declared.

Acknowledgments

The authors are grateful for the valuable advice on the revision of the scale by nursing scholars, psychologists, and professors. The authors would also like to thank the medical staff in Tianjin Medical University Metabolic Disease Hospital, Tianjin First Central Hospital, Tianjin Fourth Center Hospital, Tianjin Jixian People's Hospital.

Appendix A. Supplementary data

Supplementary data to this article can be found online at <https://doi.org/10.1016/j.ijnss.2018.09.008>.

References

[1] Albarrak AI, Mohammed R, Assery B, et al. Evaluation of diabetes care

- management in primary clinics based on the guidelines of American Diabetes Association. *Int J Health Sci (Qassim)*. 2018 Jan-Feb;12(1):40–4. PMID: 29623016.
- [2] Gui MD, Zhu DF, Zhang LY, et al. Causes and nursing of hypoglycemia in hospitalized elderly patients with type 2 diabetes mellitus. *J Nurs* 2015;(12): 56–8. <https://doi.org/10.16460/j.issn1008-9969.2015.12.056>.
- [3] Huang SG, Lu PJ, Ma XF, et al. Research progress on the fear of hypoglycemia in type 1 diabetes patients. *Chin J Nurs* 2017;(7):820–5. <https://doi.org/10.3761/j.issn.0254-1769.2017.07.011>.
- [4] Nicolucci A, Pintaudi B, Rossi MC, et al. The social burden of hypoglycemia in the elderly. *Acta Diabetol* 2015;52(4):677–85. <https://doi.org/10.1007/s00592-015-0717-0>.
- [5] Cox DJ, Irvine A, Gonder-Frederick L, et al. Fear of hypoglycemia: quantification, validation, and utilization. *Diabetes Care* 1987;10(5):617–21. PMID: 3677982.
- [6] Bradley C, Eschwege E, De PP, et al. Predictors of quality of life and other patient-reported outcomes in the PANORAMA multinational study of People with type 2 diabetes. *Diabetes Care* 2018;41(2):267. <https://doi.org/10.2337/dc16-2655>.
- [7] Dømgård M, Bagger M, Rhee NA, et al. Individual and societal consequences of hypoglycemia: a cross-sectional survey. *PGM (Postgrad Med)* 2015;127(5): 438–45. <https://doi.org/10.1080/00325481.2015.1045815>.
- [8] Williams SA, Shi L, Brenneman SK, et al. The burden of hypoglycemia on healthcare utilization, costs, and quality of life among type 2 diabetes mellitus patients. *J Diabetes Complicat* 2012;26(5):399–406. <https://doi.org/10.1016/j.jdiacomp.2012.05.002>.
- [9] Clarke WL, Gonderfrederick LA, Snyder AL, et al. Maternal fear of hypoglycemia in their children with insulin dependent diabetes mellitus. *J Pediatr Endocrinol Metab* 1998;11(Supplement):189–94. PMID: 9642659.
- [10] Grabman J, Vajda Bailey K, Schmidt K, et al. An empirically derived short form of the Hypoglycemia Fear Survey II. *Diabet Med* 2017;34(4):500–4. <https://doi.org/10.1111/dme.13162>.
- [11] Haugstvedt A, Wentzellarsen T, Aarflot M, et al. Assessing fear of hypoglycemia in a population-based study among parents of children with type 1 diabetes – psychometric properties of the hypoglycemia fear survey – parent version. *BMC Endocr Disord* 2015;15(1):1–8. <https://doi.org/10.1186/1472-6823-15-2>. 15,1(2015-01-19).
- [12] Anarte Ortiz MT, Caballero FF, Ms RDA, et al. Development of a new fear of hypoglycemia scale: FH-15. *Psychol Assess* 2011;23(2):398–405. <https://doi.org/10.1037/a0021927>.
- [13] Anarte MT, Carreira M, Machado A, et al. Identification of risk factors for suffering fear of hypoglycemia in type 1 Diabetes Mellitus patients. *Scand J Psychol* 2014;55(6):554–7. <https://doi.org/10.1111/sjop.12158>.
- [14] Pérezgarcía L, Goñiariarte MJ, Garciamouriz M. Comparison of treatment with continuous subcutaneous insulin infusion versus multiple daily insulin injections with bolus calculator in type 1 diabetes. *Endocrinol Nutr* 2015;62(7): 331–7. <https://doi.org/10.1016/j.endonu.2015.06.003>.
- [15] Wu ML. *Statistical analysis of questionnaires*. Chongqing University Press; 2010, ISBN 9787562450887.
- [16] Association WOHAD. Defining and reporting hypoglycemia in diabetes: a report from the american diabetes association workgroup on hypoglycemia. *Diabetes Care* 2005;28(5):1245. PMID: 15855602.
- [17] Gonderfrederick LA, Schmidt KM, Vajda KA, et al. Psychometric properties of the hypoglycemia fear survey-II for adults with type 1 diabetes. *Diabetes Care* 2011;34(4):801. <https://doi.org/10.2337/dc10-1343>.
- [18] Mu C, Bao J, Xing QL. Reliability and validity of Chinese version hypoglycemia fear survey-awareness scale in patients with type 2 diabetes mellitus. *Chinese J Practical Nurs* 2015;31(3):198–201. <https://doi.org/10.3760/cma.j.issn.1672-7088.2015.03.013>.
- [19] Eremenco SL, Cella D, Arnold BJ. A comprehensive method for the translation and cross-cultural validation of health status questionnaires. *Eval Health Prof* 2005;28(2):212. <https://doi.org/10.1177/0163278705275342>.
- [20] Beaton DE, Bombardier C, Guillemin F, et al. Guidelines for the process of cross-cultural adaptation of self-report measures. *Spine* 2000;25(24): 3186–91. PMID: 11124735.
- [21] Fluss R, Faraggi D, Reiser B. Estimation of the Youden Index and its associated cutoff point. *Biom J* 2010;47(4):458–72. PMID: 16161804.
- [22] Xiao SZ. *Nursing research*. third ed. Beijing: People's Medical Publishing House; 2008, ISBN 711707812X. p. 89.
- [23] Wu ML. *Questionnaire statistics analysis practice*. Chongqing: Chongqing University Press; 2010, ISBN 9787562450887. p. 207.
- [24] Schininà F, Lamanna C, da Vico L, et al. Validation of the Italian version of the questionnaire fear of hypoglycemia scales (FH-15) in type 1 diabetes. *G It Diabetol Metab* 2016;36:3–8.
- [25] Isaac Z, Feeney RO. Commentary: fear of movement/(re)injury and activity avoidance in persons with neurogenic versus vascular claudication: why are spinal stenosis patients scared stiff? *Spine J* 2012;12(4):301–3. <https://doi.org/10.1016/j.spinee.2012.03.022>.
- [26] Anarte MT, Carreira M, Machado A, et al. Identification of risk factors for suffering fear of hypoglycemia in type 1 Diabetes Mellitus patients. *Scand J Psychol* 2014;55(6):554–7. <https://doi.org/10.1111/sjop.12158>.
- [27] Xu HM. *The design and clinical application of the Hypoglycemia Fear - behavior Scale in type 2 diabetes patients*. Tianjin Medical University; 2017.
- [28] Mu C, Bao Z, Wang MJ, et al. Study on the status and related factors of fear of low blood sugar in patients with type 2 diabetes mellitus. *Chinese J Diabetes*

- 2015;(4):235–40. <https://doi.org/10.3760/cma.j.issn.1674-5809.2015.04.011>.
- [29] Xu HM, Ding WG, Mu C, et al. Qualitative study of hypoglycemia fear behavior in patients with type 2 diabetes mellitus. *Chinese J Practical Nurs* 2016;32(31):2429–32. <https://doi.org/10.3760/cma.j.issn.1672-7088.2016.31.007>.
- [30] Chun Mu. Revision of the Chinese version of the hypoglycemia fear questionnaire and its application in patients with type 2 diabetes. Tianjin Medical University; 2015.
- [31] Cox DJ, Irvine A, Gonder-Frederick L, et al. Fear of hypoglycemia; quantification, validation, and utilization. *Diabetes Care* 1987;10(5):617–21. PMID: 3677982.
- [32] Portney LG, Watkins MP. *Foundation of clinical research: application to practice*. second ed. Upper Saddle River, NJ: Prentice Hall; 2000, ISBN 9780838526958.