

## CLINICAL REPORT

# First reported *CABP2*-related non-syndromic hearing loss in Northern Europe

Inger Norlyk Sheyanth<sup>1,2,3</sup>  | Allan Thomas Højland<sup>1,2,3</sup>  | Henrik Okkels<sup>1,4</sup> | Ihab Lolas<sup>1,4</sup> | Christian Thorup<sup>1,5</sup> | Michael Bjørn Petersen<sup>1,2,3</sup> 

<sup>1</sup>Research and Knowledge Center in Sensory Genetics, Aalborg University Hospital, Aalborg, Denmark

<sup>2</sup>Department of Clinical Genetics, Aalborg University Hospital, Aalborg, Denmark

<sup>3</sup>Department of Clinical Medicine, Aalborg University, Aalborg, Denmark

<sup>4</sup>Department of Molecular Diagnostics, Aalborg University Hospital, Aalborg, Denmark

<sup>5</sup>Department of Audiology, Aarhus University Hospital, Aarhus, Denmark

## Correspondence

Inger Norlyk Sheyanth, Department of Clinical Genetics, Aalborg University Hospital, Ladegårdsgade 5, 5. Sal, 9000 Aalborg, Denmark.  
Email: Inger2104@hotmail.com

## Funding information

The Obel Family Foundation grant number 27915.

## Abstract

**Background:** *CABP2*-related non-syndromic hearing loss have only been reported in a few families worldwide (Iran, Turkey, Pakistan and Italy). The hearing loss was in these cases described as prelingual, symmetrical, and moderate to severe.

**Methods:** Following DNA isolation, exome sequencing was performed in 123 genes related to non-syndromic hearing loss. Variant verification and carrier testing were performed by direct sequencing.

**Results:** We report the first Northern European individual with *CABP2*-related hearing loss: an 8-year-old Danish Caucasian boy with non-syndromic, prelingual, and sensorineural hearing loss, who is homozygous for the splice site variant *CABP2*: c. 637+1G>T previously found in three Iranian families and in one Pakistani family. Both parents are of Danish Caucasian origin with no known history of consanguinity. This is in contrast to the four reported Middle Eastern families, who all were consanguineous. However, loss of heterozygosity in a 3.2 Mb area on chromosome 11 including *CABP2* was observed, suggesting a common parental ancestor.

**Conclusion:** We report the first case of *CABP2*-related autosomal recessive hearing loss in Northern Europe. The index is of Danish Caucasian origin and found to be homozygous for the splice site variant c.637+1G>T.

## KEYWORDS

autosomal recessive, *CABP2*, hearing loss

## 1 | INTRODUCTION

Congenital hearing loss is a frequent birth defect affecting approximately 3/1000 newborns (Erenberg et al., 1999; Mehl & Thomson, 1998; White, 2004). Early detection and intervention is paramount for language development in these children (Moeller, 2000; Yoshinaga-Itano et al., 1998). Standardized hearing screening of infants have, therefore, been introduced in most developed countries. A national screening program

of infants at 3 days of age was launched in Denmark in 2005 with a screening density currently exceeding 95% (Linnebjerg et al., 2017).

Hearing loss can occur isolated with abnormalities restricted to the inner ear (non-syndromic hearing loss) or can be seen as part of a syndrome with multiple abnormalities (syndromic hearing loss). Non-syndromic hearing loss (NSHL) accounts for approximately 70% of hereditary hearing loss and multiple modes of inheritance have been reported, of

This is an open access article under the terms of the Creative Commons Attribution-NonCommercial-NoDerivs License, which permits use and distribution in any medium, provided the original work is properly cited, the use is non-commercial and no modifications or adaptations are made.

© 2021 The Authors. *Molecular Genetics & Genomic Medicine* published by Wiley Periodicals LLC.

which, autosomal recessive being the most prevalent (Smith et al., 2005). To date 76 genes have been reported in relation to autosomal recessive non-syndromic hearing loss (ARNSHL) (Hereditary Hearing Loss Homepage accessed 4 February 2020) including *CABP2* (OMIM 607314).

*CABP2* is part of a family of Ca<sup>2+</sup>-binding proteins (CABPs) with high similarity to calmodulin. Ca<sup>2+</sup>-binding protein 2 is expressed in the cochlea and modulate presynaptic influx of calcium in the inner hair cells thus affecting further transmission of auditory information to the brain via voltage gated Ca-channels (Cui et al., 2007). Ca<sup>2+</sup>-binding protein 2 (*CABP2*) is found to regulate hearing sensitivity in inner hair cells and is required for the normal function of the peripheral auditory system (Yang et al., 2018).

ARNSHL as a result of pathogenic variants in *CABP2* has previously been reported in four Iranian families (Koohiyan et al., 2019; Schrauwen et al., 2012), one Turkish family (Bademci et al., 2016), one Italian family (Picher et al., 2017), and one Pakistani family (Richard et al., 2019) (Table 1). The hearing loss in these cases was described as prelingual, symmetrical, moderate-severe, and more pronounced in the mid frequencies resulting in U-shape audiogram. So far, four different pathogenic variants in *CABP2* have been identified.

## 2 | MATERIALS AND METHODS

### 2.1 | Clinical report

We present the molecular genetic findings of an 8-year-old boy with prelingual, sensorineural, moderate, and symmetrical hearing loss. The child was born in 2010 from Danish Caucasian non-consanguineous parents following a normal pregnancy (gestation week 42). The birth was reported to be fast and the boy was born within minutes at home, initially blue and quiet but had a quick recovery. Birthweight was 3400 g and length was 51 cm. No treatment for jaundice was needed and blood tests showed no signs of CMV infection.

Bilateral hearing loss was detected when the patient was 3 days old by the national standardized hearing screening. As a young child, he had numerous bilateral otitis media infections and underwent eardrum tubulation four times. At the age of seven, he was referred from a private practitioner to hearing loss treatment with hearing aids. The patient's hearing loss was symmetrical, moderate, and more pronounced in the mid frequencies resulting in a U-shaped audiogram (Figure 1).

At the age of eight, the boy was referred to genetic counseling. Elaborate family history on the patient's mother's side revealed other family members with non-syndromic hearing loss and the need for hearing aids in adolescence and early adulthood (Figure 2). The mother of the patient also had impaired hearing, but with no need for hearing aids at the age of 35. Based on the pedigree, an autosomal dominant inheritance initially seemed most likely.

### 2.2 | Editorial policies and ethical considerations

Oral informed consent was obtained by the patient's father at consultation.

### 2.3 | Molecular evaluation, verification, and carrier testing

DNA was isolated according to standard procedures from blood leukocytes. Exome sequencing was performed using SureSelect XT HS exome kit (Agilent Technologies Inc.) and the library was sequenced on NextSeq (Illumina Inc.). Inspection and visualization of variants in the 123 genes related to non-syndromic hearing loss were performed manually using VarSeq version 1.4.4 (Golden Helix Inc.). Subsequent variant verification and carrier testing of the patient's father were performed by direct sequencing using forward primer GAGCTACGGGACGCCTTC and reverse primer

Family ID	CABP2 mutations	Country
Sh11	c.637+1C>T; c.637+1G>T	Iran (Schrauwen et al., 2012)
Sh10	c.637+1C>T; c.637+1G>T	
He	c.637+1C>T; c.637+1G>T	
1239	c.490-1G>T; c.490-1G>T	Turkey (Bademci et al., 2016)
—	c.466G>T; c.466G>T	Italy (Picher et al., 2017)
—	c.311G>A; c.311G>A	Iran (Koohiyan et al., 2019)
DEM4545	c.637+1C>T; c.637+1G>T	Pakistan (Richard et al., 2019)
NSHL57	c.637+1C>T; c.637+1G>T	Denmark (this case)

TABLE 1 Overview of pathogenic variants in *CABP2* reported to date

**FIGURE 1** Audiogram of index. Hearing level in dB on the Y-axis and frequency in hertz on the X-axis. Red O: Air conduction, right ear, unmasked. Blue X: Air conduction, left ear, unmasked. Red <: Bone conduction, right ear, unmasked. Blue >: Bone conduction, left ear, unmasked. Red |: Bone conduction, right ear, masked. Blue |: Bone conduction. SRT: Speech Reception Threshold. DS: Discrimination score

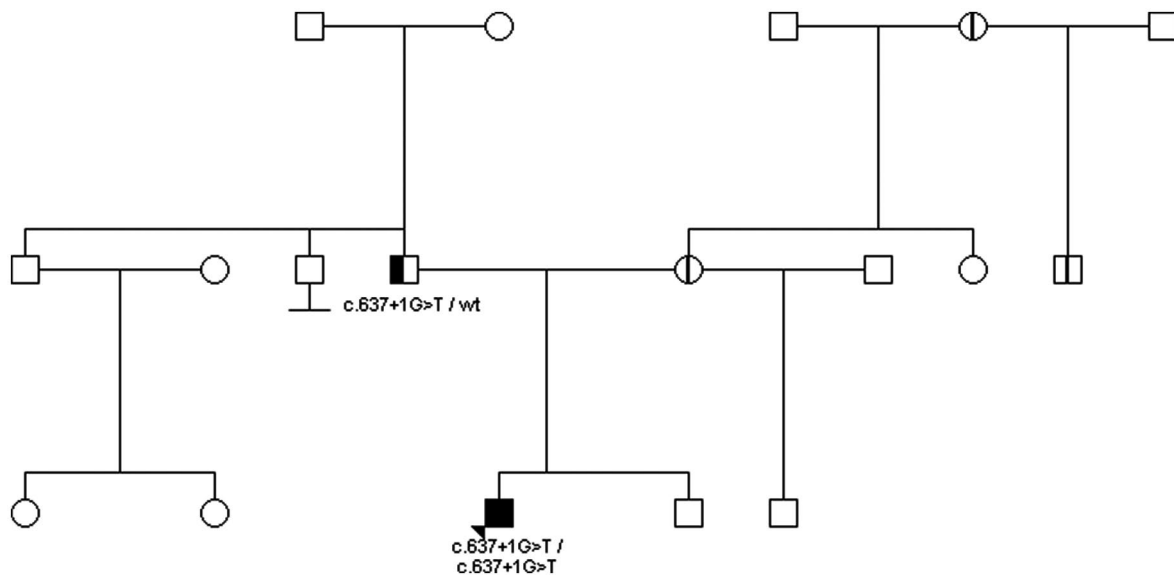
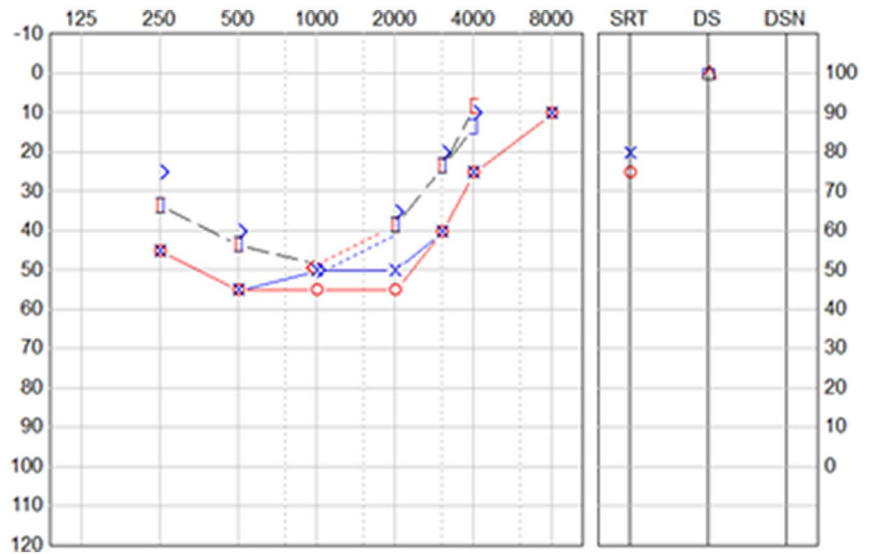

**FIGURE 2** Family pedigree. The arrow represents the index patient. Black shading indicates homozygosity for *CABP2* c.637+1G>T and halved black shading indicates heterozygosity. The vertical line represents family history of adolescence/adult onset of non-syndromic hearing loss

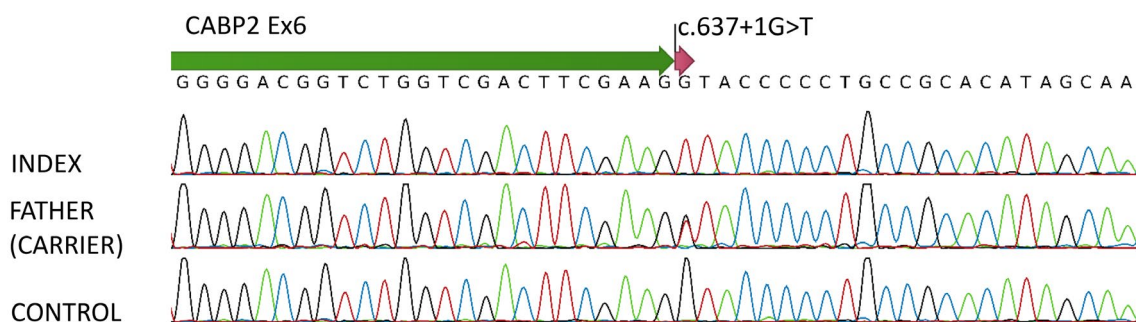

**FIGURE 3** Direct sequencing results of the (NM 016366.3) *CABP2* c.637+1G>T mutation in the index patient, carrier (father) and control

TGCTGTGCGGTTTCTTATCTG. Pathogenic variants were submitted to the central variant database ClinVar.

### 3 | RESULTS

The patient was found homozygous for the known splice site variant *CABP2* (NM\_016366.2), c.637+1G>T (Figure 3). No other causative variants were identified in the other sequenced genes. The homozygous *CABP2* mutation has previously been seen in three Iranian families and in one Pakistani family (Richard et al., 2019; Schrauwen et al., 2012). Functional studies have shown that this splice site mutation leads to complete skipping of exon 6, expected to cause a frameshift thus resulting in a premature truncation of the protein (Schrauwen et al., 2012).

The hearing loss in our index and in the abovementioned families, are inherited in an autosomal recessive manner. Only carrier testing of the patient's father was possible, where heterozygosity of the mutation was confirmed (Figure 3). The patient's mother and the remaining family members suffering from hearing loss on her side of the family remain genetically unresolved.

In this family, no history of consanguinity was reported, however, a 3.2 Mb area with loss of heterozygosity was identified on chromosome 11 involving *CABP2* (Chr11:64577620-67817743 (GRCh37)), suggesting a common parental ancestor.

### 4 | DISCUSSION

Homozygosity for *CABP2*: c. 637+1G>T was shown to be the cause of non-syndromic, autosomal recessive hearing loss in this Danish Caucasian patient. To our knowledge, *CABP2*-related hearing loss has only previously been reported worldwide in seven unrelated families (Table 1), thus, making our patient the first Northern European with *CABP2*-related hearing loss. Furthermore, our index is the first European hearing loss patient with homozygosity for the *CABP2* c.637+1G>T mutation, making an accurate estimate of carrier frequency of pathogenic variants in *CABP2* in Northern Europe and in Denmark difficult. According to the Genomic Aggregation Database (GnomAD), the allelic frequency of this mutation in non-Finnish Europeans is approximately 0.001 and 0.003 in Finnish Europeans (Lek et al., 2016) indicating that several cases of undiagnosed *CABP2*-related hearing loss due to homozygosity for this mutation exist in European populations.

Consanguinity was reported in six of the seven previously reported families with *CABP2*-related hearing loss.

Family relations in the Turkish family were not described (Bademci et al., 2016). In the current family, no known history of consanguinity was reported. However, analysis of the exome data from our index, showed loss of heterozygosity in a 3.2 Mb area on chromosome 11 involving *CABP2* (Chr11:64577620-67817743 (GRCh37)), suggesting a common parental ancestor.

Family history revealed additional cases of hearing impairment on the patient's mother's side of the family, including his mother, who had a slight hearing loss. The patient's grandmother and uncle on his mother's side were both treated with hearing aids in their forties and teenage years, respectively. These affected relatives remain, however, genetically unresolved.

The protein encoded by *CABP2*, Ca<sup>2+</sup>-binding protein 2, has previously been shown also to be present in the retina (Haeseleer et al., 2000). Ophthalmological investigations have, therefore, been performed on individuals with *CABP2*-related hearing loss revealing no eye pathology (Schrauwen et al., 2012). To date no additional clinical manifestations have been reported, although ectomorphic and marfanoid features have been suspected (Schrauwen et al., 2012). None of these distinctive features were obvious in the index with the proviso, that he was only 8 years old at the time of consultation.

### 5 | CONCLUSION

To the best of our knowledge, this is the first report of a patient with *CABP2*-related autosomal recessive hearing loss in Northern Europe and the second in Europe. The index is of Danish Caucasian origin and found to be homozygous for the splice site mutation c.637+1G>T. This specific mutation has only previously been reported in three Iranian and one Pakistani family all with a family history of consanguinity. In this family no history of consanguinity was noticed, however, loss of heterozygosity in a 3.2 Mb area including *CABP2* on chromosome 11 suggested a common parental ancestor.

### 6 | DATA AVAILABILITY STATEMENT

The data that support the findings of this study are available on reasonable request from the corresponding author. The data are not publicly available due to privacy or ethical restrictions.

### ACKNOWLEDGMENTS

We would like to thank the family involved.

## CONFLICT OF INTEREST

The authors have declared no conflict of interest.

## AUTHOR CONTRIBUTIONS

INS and MBP drafted the manuscript. Exome sequencing and result interpretation were performed by HO, IL, and ATH. INS, MBP, and CT provided clinical input. All authors reviewed the results and contributed to critical revision of the manuscript.

## ORCID

Inger Norlyk Sheyanth  <https://orcid.org/0000-0002-5408-8701>

Allan Thomas Højland  <https://orcid.org/0000-0003-0014-3004>

Michael Bjørn Petersen  <https://orcid.org/0000-0003-0316-8207>

## REFERENCES

- Bademci, G., Foster, J. 2nd, Mahdih, N., Bonyadi, M., Duman, D., Cengiz, F. B., Menendez, I., Diaz-Horta, O., Shirkavand, A., Zeinali, S., Subasioglu, A., Tokgoz-Yilmaz, S., Huesca-Hernandez, F., de la Luz, A.-S., Dominguez-Aburto, J., Hernandez-Zamora, E., Montenegro, P., Paredes, R., Moreta, G., ... Tekin, M. (2016). Comprehensive analysis via exome sequencing uncovers genetic etiology in autosomal recessive nonsyndromic deafness in a large multiethnic cohort. *Genetics in Medicine*, *18*, 364–371. <https://doi.org/10.1038/gim.2015.89>
- Cui, G., Meyer, A. C., Calin-Jageman, I., Neef, J., Haeseleer, F., Moser, T., & Lee, A. (2007). Ca<sup>2+</sup>-binding proteins tune Ca<sup>2+</sup>-feedback to Ca<sub>v</sub>1.3 channels in mouse auditory hair cells. *Journal of Physiology*, *585*, 791–803.
- Erenberg, A., Lemons, J., Sia, C., Trunkel, D., & Ziring, P. (1999). Newborn and infant hearing loss: Detection and intervention. American Academy of Pediatrics. Task Force on Newborn and Infant Hearing. *Pediatrics*, *103*, 527–530.
- Haeseleer, F., Sokal, I., Verlinde, C. L., Erdjument-Bromage, H., Tempst, P., Pronin, A. N., Benovic, J. L., Fariss, R. N., & Palczewski, K. (2000). Five members of a novel Ca(2+)-binding protein (CABP) subfamily with similarity to calmodulin. *Journal of Biological Chemistry*, *275*, 1247–1260.
- Koohiyani, M., Noori-Dalooi, M. R., Hashemzadeh-Chaleshtori, M., Salehi, M., Abtahi, H., & Tabatabaiefar, M. A. (2019). A novel pathogenic variant in the CAPB2 gene causes severe nonsyndromic hearing loss in a consanguineous Iranian family. *Audiol Neurootol*, *24*, 258–263. [10.1159/000502251](https://doi.org/10.1159/000502251)
- Lek, M., Karczewski, K. J., Minikel, E. V. et al (2016). Analysis of protein-coding genetic variation in 60,760 humans. *Nature*, *536*, 285–291.
- Linnebjerg, L. B., Hansen, A. E., & Møller, T. R. (2017). Hearing screening in newborns in the Central Denmark Region. *Danish Medical Journal*, *64*, A5329.
- Mehl, A. L., & Thomsen, V. (1998). Newborn hearing screening: the great omission. *Pediatrics*, *101*, E4.
- Moeller, M. P. (2000). Early intervention and language development in children who are deaf and hard of hearing. *Pediatrics*, *106*, E43.
- Picher, M. M., Gehrt, A., Meese, S., Ivanovic, A., Predoehl, F., Jung, S., Schrauwen, I., Dragonetti, A. G., Colombo, R., Van Camp, G., Strenzke, N., & Moser, T. (2017). Ca<sup>2+</sup>-binding protein 2 inhibits Ca<sup>2+</sup>-channel inactivation in mouse inner hair cells. *Proceedings of the National Academy of Sciences of the United States of America*, *114*, E1717–E1726. <https://doi.org/10.1073/pnas.1617533114>
- Richard, E. M., Santos-Cortez, R. L. P., Faridi, R., Rehman, A. U., Lee, K., Shahzad, M., Acharya, A., Khan, A. A., Imtiaz, A., Chakchouk, I., Takla, C., Abbe, I., Rafeeq, M., Liaqat, K., Chaudhry, T., Bamshad, M. J., Nickerson, D. A., University of Washington Center for Mendelian Genomics, ... Riazuddin, S. (2019). Global genetic insight contributed by consanguineous Pakistani families segregating hearing loss. *Human Mutation*, *40*, 53–72. <https://doi.org/10.1002/humu.23666>
- Schrauwen, I., Helfmann, S., Inagaki, A., Predoehl, F., Tabatabaiefar, M. A., Picher, M. M., Sommen, M., Zazo Seco, C., Oostrik, J., Kremer, H., Dheedene, A., Claes, C., Fransen, E., Chaleshtori, M. H., Coucke, P., Lee, A., Moser, T., & Van Camp, G. (2012). A mutation in CABP2, expressed in cochlear hair cells, causes autosomal-recessive hearing impairment. *American Journal of Human Genetics*, *91*, 636–645. <https://doi.org/10.1016/j.ajhg.2012.08.018>
- Smith, R. J., Bale, J. F. Jr, & White, K. R. (2005). Sensorineural hearing loss in children. *The Lancet*, *365*, 879–890.
- White, K. R. (2004). Early hearing detection and intervention programs: opportunities for genetic services. *American Journal of Medical Genetics Part A*, *130A*, 29–36.
- Yang, T., Hu, N., Pangršič, T., Green, S., Hansen, M., & Lee, A. (2018). Functions of CaBP1 and CaBP2 in the peripheral auditory system. *Hearing Research*, *364*, 48–58. <https://doi.org/10.1016/j.heares.2018.04.001>
- Yoshinaga-Itano, C., Sedey, A. L., Coulter, D. K., & Mehl, A. L. (1998). Language of early- and later-identified children with hearing loss. *Pediatrics*, *102*, 1161–1171.

**How to cite this article:** Sheyanth IN, Højland AT, Okkels H, Lolas I, Thorup C, Petersen MB. First reported CABP2-related non-syndromic hearing loss in Northern Europe. *Mol Genet Genomic Med*. 2021;9:e1639. <https://doi.org/10.1002/mgg3.1639>