

Received:  
26 October 2018  
Revised:  
31 January 2019  
Accepted:  
1 March 2019

Cite as: Roberto Romaniello,  
Antonia Tamborrino,  
Alessandro Leone.  
Development of a centrifugal  
separator for grape marc:  
effect of the blade position and  
rotor speed on grape seed  
separation performance.  
Heliyon 5 (2019) e01314.  
doi: [10.1016/j.heliyon.2019.e01314](https://doi.org/10.1016/j.heliyon.2019.e01314)



# Development of a centrifugal separator for grape marc: effect of the blade position and rotor speed on grape seed separation performance

Roberto Romaniello<sup>a</sup>, Antonia Tamborrino<sup>b</sup>, Alessandro Leone<sup>a,\*</sup>

<sup>a</sup> Department of the Science of Agriculture, Food and Environment, University of Foggia, Via Napoli, 25 - 71122, Foggia, Italy

<sup>b</sup> Department of Agricultural and Environmental Science, University of Bari Aldo Moro, Via Amendola 165/A, 70126 Bari, Italy

\* Corresponding author.

E-mail address: [alessandro.leone@unifg.it](mailto:alessandro.leone@unifg.it) (A. Leone).

## Abstract

The present study was conducted to find a method to separate grape seeds and soft solids from fresh marc at the end of wine-making processes. Interest in these by-products is growing owing to the high content of phytochemicals and other components useful in cosmetic and pharmaceutical industries. A prototype centrifugal separator was developed and its separation performance was evaluated. Four different reel speed rotations (480, 576, 687, and 842 rpm) and two different blade adjustments (Type-A blade with 1.5 mm and Type-B blade with 8.5 mm) were evaluated at the same mass flow rate ( $350 \text{ kg} \cdot \text{h}^{-1}$ ).

Results showed that the separation of seeds from the fresh grape marc using a centrifugal separator is possible and that this could be achieved by setting the optimal rotation speed of the reel (480 rpm) and establishing the best distance between the blades and the cylindrical separator (8.5 mm with TypeB blades).

Keywords: Food science, Food technology

## 1. Introduction

Grape cultivation is practised worldwide, according to the Statistics department of the [International Organisation of Vine and Wine \(OIV\)](#). In 2017 the vineyard area destined for the production of wine grapes, table grapes, or dried grapes was 7.5 million hectares, 14% of which were in Spain, 11% in China, 10% in France, 9% in Italy, 7% in Turkey, and about the 50% in the rest of the world.

According to the same report, the mean total grape production in the world in the 2012–2016 period was 75 million tonnes, of which 50% was wine grape and 50% was fresh and dried grape.

According to [Torres et al. \(2002\)](#) and [Toscano et al. \(2013\)](#), after the wine process the percentage of fresh grape marc is approximately 13–27% of the grapes, depending on the cultivar (because of different solid-liquid ratios), the type of machine used to press the grapes, and the maximum pressure reached. Considering these data, millions of tonnes of marc are produced annually in the world.

Fresh grape marc consists of a mixture of approximately 16.7% grape seeds, 72.2% skins, and 11.1% stalks ([Toscano et al., 2013](#)).

In many countries, grape marc is considered a biomass waste product and has had a significant impact on the environment owing to the high phenol content that considerably increases both the chemical and biochemical oxygen demands ([Spigno and De Faveri, 2007](#)). Several governmental policies have therefore mandated that wineries must track the use of marc by recording the quantity generated and the method of safe disposal, to avoid environmental problems.

Grape marc is a form of biomass that would typically be considered a by-product for other processes. A few processes employ the fresh marc ([Muhlack et al., 2018](#)), whereas others employ only the soft solids (skins and stalks) or only the seeds. Grape marc is traditionally used to produce grape spirit (ethanol) by means of steam distillation after the fermentation of available sugars ([Buglass, 2011](#); [Silva et al., 2000](#)). In addition, other potential uses were studied, for example for energy as reported by [Schönnenbeck et al. \(2016\)](#), [Caputo et al. \(2005\)](#), and [Hernández et al. \(2010\)](#); for the composting process ([Paradelo et al., 2010](#)); or for animal feed with good results ([Baumgärtel et al., 2007](#); [Greenwood et al., 2012](#)), even if [Baumgärtel et al. \(2007\)](#) highlighted that the incorporation of grape marc into the ruminant diet can reduce digestibility.

Grape marc serves as a good source of phytochemicals (phenolics, pigments, and antioxidants) with potential health benefits ([Ferri et al., 2016](#); [Gambacorta et al., 2017](#); [Ribeiro et al., 2015](#)).

A few of these phytochemicals, such as anthocyanins and resveratrol, are found in grape skins (Waterhouse et al., 2016; Walle et al., 2004).

Calabriso et al. (2016) studied the potential health benefits of the main polyphenols of grape skin extracts, namely trans-resveratrol, trans-piceid, kaempferol, and quercetin.

In Sarkar et al. (2012), the potential use of grape marc as a feedstock for bioethanol and biogas production was highlighted. Mendes et al. (2013) investigated grape skins separated from marc for the production of bioethanol. Dinuccio et al. (2010) examined the use of fresh marc and grape stalk as feedstock for biomethane production through anaerobic digestion. In this last study, the investigators highlighted the low yield of biogas owing to the presence of seed lignin.

Another important use of marc relates to the oil extracted from the previously separated seeds. As reported in Bhosle and Subramanian (2005), grape seeds consist of approximately 10–20% oil (calculated as the mass of oil extracted from 100 g of dried grape seeds), which is usually extracted using a solvent and refined before use or, more recently, extracted by pressing followed by a solvent.

In Europe, grape marc produced in the wine-making process was mandatorily used in the distilling industry, but Council Regulation (EC) No. 479/2008 and Commission Regulation (EC) No. 555/2008 allowed the producers to seek new opportunities for the exploitation of the fresh and also exhausted grape marc. The potential uses of grape marc understandably increase when the fresh grape marc is separated into its two main components: seeds and soft solids (skins and stalks).

Currently, the seeds can be separated by sieving the previously dried marc with horizontal or rotary sieves. Approximately 90% of the seeds are recovered in this manner. However, owing to the oxidation caused by the drying process, the potential uses of the soft solids are limited; for example, the extraction of components with potential health benefits from the soft solids is no longer possible. When the grape seeds are separated by sieving from fresh marc, the yield for seed recovery is less than 40%, thereby undermining the purpose of the separation.

To date, several new de-stoning technologies based on strong centrifugal force have been developed for the separation of stones from fruits. In the food industry, pulper machines are designed for the separation of pulp and pits for most fruits including mangoes, peaches, apricots, and cherries. In the olive oil industry, the de-stoner machine is sometimes used to produce oil from de-stoned olive pastes, as reported by Romaniello et al. (2017), Servili et al. (2017), and Gambacorta et al. (2010), or used to separate the fragments of olive pits from the pomace as reported by Leone et al. (2015).

Although this technology based on centrifugal force is widely used in many fruit processing industries and in the re-use of by-products, the technology is never

used for grape seed separation from grape marc and no scientific studies exist that investigate its potential use. A technology that allows, in line with the wine-making process, direct treatment of fresh marc to separate seeds and soft solids would increase their potential uses in sectors such as cosmetics, pharmaceuticals, human nutrition, animal feed, or health. This would increase the profit of wine producers while reducing the environmental problems related to the marc disposal.

The aim of the study was to design and construct a prototype of a centrifugal separator to separate grape seeds from fresh marc after the wine-making process, and to evaluate the effect of the centrifugal separator mechanical components on the separation performance for seeds and soft solids starting with fresh marc. The final goal was to identify the best setting for the blade position and for the rotor speed of the centrifugal separator to maximise the seed yield, to reduce seed breakage, and to get fresh soft solids without seeds.

## 2. Materials and methods

### 2.1. Mass balance and moisture of Negroamaro grape marc

Tests were performed on a 5 kg sample of grape marc obtained from grapes of the Negroamaro variety (medium ripeness) that originated from the Cantina Due Palme S.r.l. winery (Cellino San Marco, BR, Italy) during August to September, 2017.

Grape marc was collected at the end of the red wine process, in particular after the pneumatic pressing phase. During the red wine process, stalks were removed from crushed grapes before the fermentation process. Therefore, the fresh marc used for all the tests was composed of skins and seeds only.

The different components of the marc (skins and seeds) were separated using standard sieves having different holes diameters (Retsch test sieve, Retsch Italia, Verder Scientific S.r.l., Torre Boldone, BG, Italy), followed by hand-separating until perfect separation was achieved.

The moisture content of both fractions was determined according to the analytical method of UNI EN 14774:2009.

### 2.2. The centrifugal separator

The centrifugal separator (Fig. 1) was assembled by the research team by using the component built by MORI-TEM s.r.l., Tavernelle Val di Pesa (FI, Italy). The machine is made by AISI 304 stainless steel and consists of:

- A hopper for marc loading with a feeding screw was driven by a three-phase 0.37 kW electric motor.

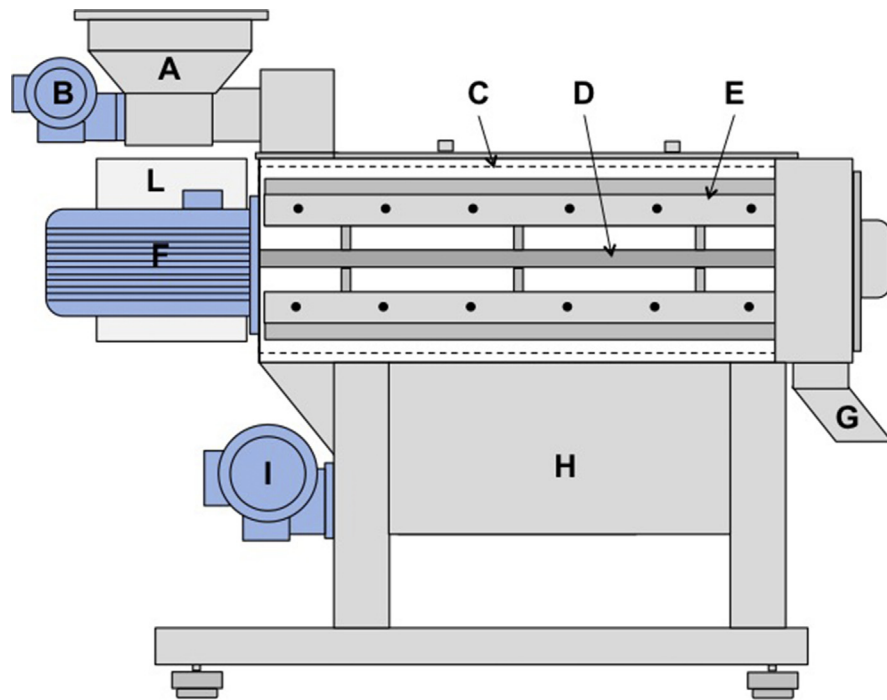

**Fig. 1.** Centrifugal separator schemes, (A) hopper for marc loading, (B) gear electric motor connected to the screw, (C) cylinder, (D) reel, (E) blade, (F) electric motor connected to the reel, (G) discharge and conveying section of the seeds, (H) collection section of the soft solids, (I) gear electric motor connected to the screw, (L) electric panel.

- A seed separation section (Fig. 2) consisted of a fixed horizontal cylindrical drum with 2.5 mm holes on the external surface. The drum had a length of 1000 mm and a diameter of 300 mm. Inside the cylinder, a reel had three blades arranged in a 120° configuration. The reel and the outer cylinder had the same length. Each blade was soldered onto the reel with an offset of 1° with respect to the longitudinal axis. This arrangement was used to allow the seeds to advance from the loading section to the unloading section. Each blade was equipped with a secondary adjustable blade screwed onto it, to allow adjustment of the distance between blade and cylinder. The reel was driven by an electric motor having a nominal power of 4 kW.
- A discharge section conveyed the separated seeds.
- A collection section for the soft solids had a screw driven by an electric gear motor having a nominal power of 0.37 kW.
- A chassis with 4 feet of support equipped with anti-vibration rubbers.
- An electrical control panel managed all electric motors and safety systems. All electric motors were controlled by an inverter to allow rotation speed adjustment.

The grape marc was uploaded into the hopper and fed into the drum through a cochlea. Once in the drum, the three-blade rotating reel forced the marc to rub on the

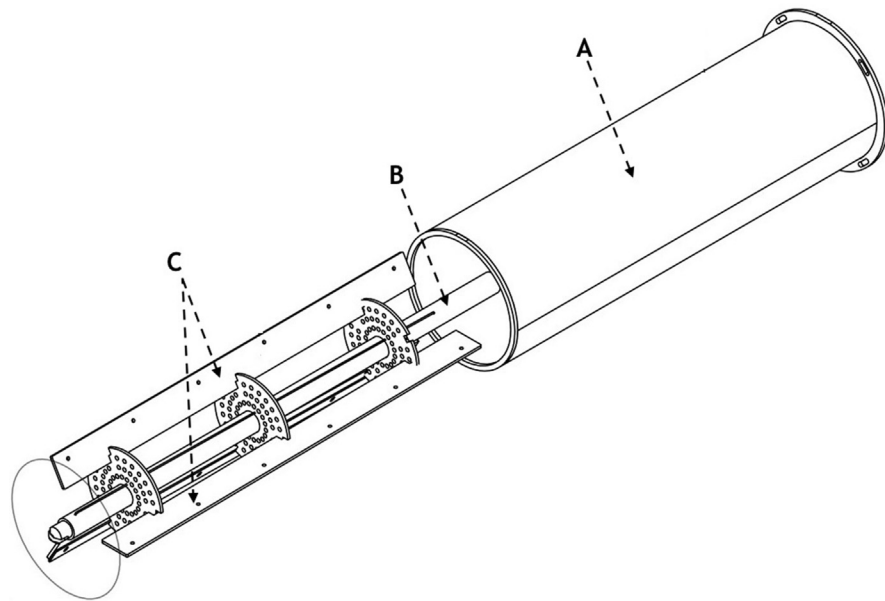

**Fig. 2.** Seeds separation section, (A) cylinder, (B) reel, (C) blades.

perforated wall of the drum, pushing the soft solids through the holes. The hole size was such that only soft solids could exit; whereas, the seeds stayed in the drum and were discharged at the opposite end of the feeder. The soft solids exited through the holes in the drum and fell into the collection tank.

### 2.3. Experimental procedure

Seed separation tests with different machine adjustment conditions were performed and the samples of seeds and soft solids were collected.

The separation tests were conducted with the electric motor connected to the reel set at four different frequencies: 25, 30, 35, and 45 Hz, corresponding to rotation speeds of 480, 576, 672, and 864 rpm, respectively.

Two different blades adjustments were evaluated for each rotation speed. A distance of 1.5 mm between blade and cylinder was considered for the first blade adjustment (Type-A blade), whereas a distance of 8.5 mm between blade and cylinder was considered for the second blade adjustment (Type-B blade) (Fig. 3).

A total of 10 different comparative tests were conducted. Each test was performed at the same mass flow rate of  $350 \text{ kg} \cdot \text{h}^{-1}$  and with a 2.5 h duration.

Type-A and Type-B blade settings were chosen after a dimensional analysis of the grape seeds contained in fresh marc. In particular, the frequency classes (explained in Section 2.4) of the major and minor axis lengths of the seeds were determined (data not shown). The analysis indicated that the larger seeds had a last frequency

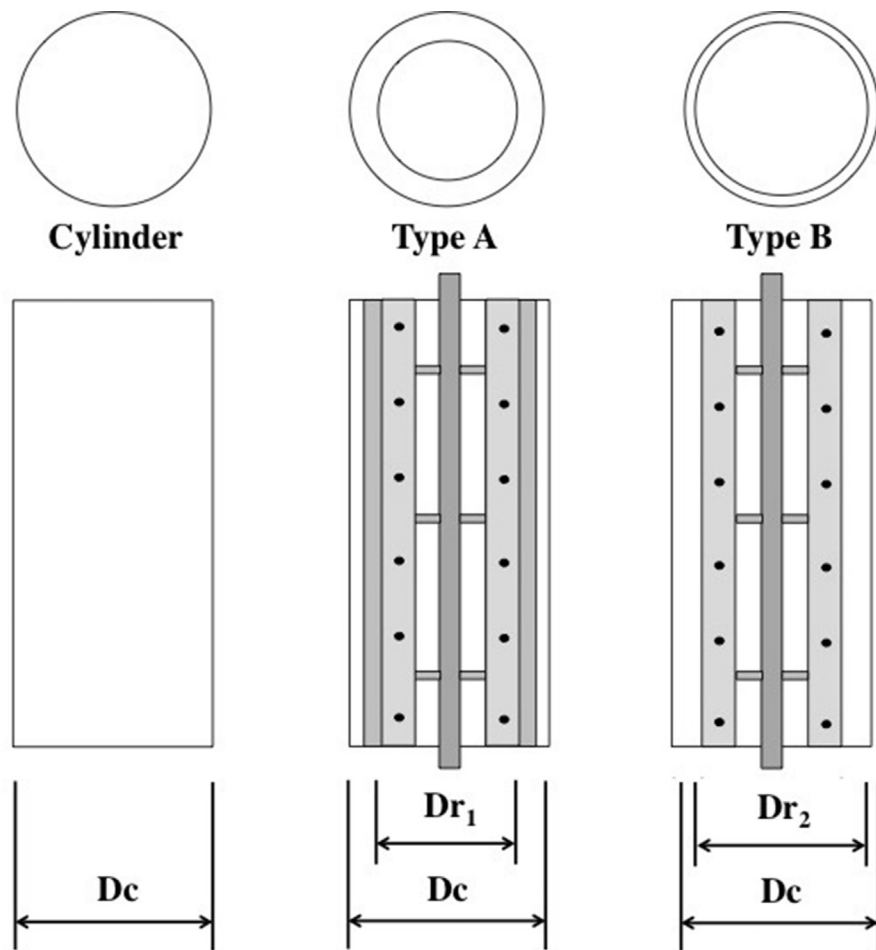

**Fig. 3.** Blade adjustment schemes,  $D_c = 300$  mm,  $D_{r1} = 291.5$  mm,  $D_{r2} = 298.5$  mm.

class of the major axis length equal to 7.5 mm and the smaller seeds had a first frequency class of the minor axis length equal to 2.1 mm. Therefore, the Type-A blade (1.5 mm) was set to a distance less than 2.1 mm, assuming that a distance between 7.5 mm and 2.1 mm would lead to the consequent breakage of the seeds owing to their entrapment between blade and cylinder. The Type-B blade (8.5 mm) was set to a distance greater than 7.5 mm. It is important to underline that the 1.5 mm distance was also the minimum tolerance between blade and cylinder.

The experimental tests were performed at the Cantina Due Palme S.r.l. from August to September, 2017.

To evaluate the separation efficiency of the machine, the seeds of each condition considered were subjected to image analysis to determine their area. The frequency distributions of the areas were successively compared with that of the control test obtained by hand-separated seeds. The area distribution of the control test was obtained by analysing the separated seeds.

## 2.4. Grape seed size distribution and statistical analysis

A set of 162 digital images of seeds was collected that consisted of 18 images for each rotation speed and blade distance considered and included the control test ((18 + 18) × 4 × 2 images). Digital images were acquired using a colour charge-coupled device (CCD) camera having a spatial resolution of 1024 × 1024 pixels and a colour depth of 24 bits per pixel. The images were processed using the image processing toolbox of MATLAB® (Mathworks Inc., Natick, MA, USA) to obtain the binary image of the seeds. For each image, the number and area of the seeds were calculated. A spatial reference in each image was used to calculate the area in mm<sup>2</sup>. The area data collected from the digital images of the seeds were processed using the statistical toolbox of MATLAB®.

The number of the frequency classes was determined using Doane's rule (Eq. 1). Doane's rule modifies Sturges's rule by adding extra classes depending on the data skewness determined by Pearson's coefficient:

$$k = 1 + \log_2 N + \log_2 \left( 1 + \frac{\sqrt{b_1}}{\sigma \sqrt{b_1}} \right) \quad (1)$$

where

$k$  is the frequency class number;

$N$  is the number of samples;

$1 + \log_2 N$  is Sturges's rule;

$\log_2 \left( 1 + \frac{\sqrt{b_1}}{\sigma \sqrt{b_1}} \right)$  is Doane's rule;

$\sqrt{b_1} = \frac{\sum(x-\bar{x})^3}{\sqrt{[\sum(x-\bar{x})^2]^3}}$  is Pearson's coefficient of skewness moment; and

$\sigma$  is the standard deviation.

A normal fitting model was used to obtain the area distributions (Eq. (2)) for each data series:

$$y = \frac{1}{\sigma \sqrt{2\pi}} \cdot e^{-\frac{(x-\mu)^2}{2\sigma^2}} \quad (2)$$

For each distribution, the mean, mode, sigma, kurtosis, and skewness were calculated. The skewness ( $\gamma_1$ ) index was calculated as follows:

$$\gamma_i = \frac{1}{\sigma^3} \left[ \frac{\sum_i (x_i - \mu)^3 f_i}{\sum_i f_i} \right] \quad (3)$$



For both Eq. (2) and Eq. (3),  $\mu$  is the mean of the distribution,  $\sigma$  is the standard deviation, and  $f_i$  is the frequency associated with each  $x_i$ .

The distribution curves were obtained using the distribution fitting toolbox of MATLAB<sup>®</sup>. The goodness of fit of each distribution was determined by fitting the data points with a two-term normal-fitting equation:

$$y = a_1 \cdot e^{-\left(\frac{x-b_1}{c_1}\right)^2} + a_2 \cdot e^{-\left(\frac{x-b_2}{c_2}\right)^2} \quad (4)$$

All experimental data were analysed with the analysis of variance (ANOVA) and Tukey's test with  $p < 0.05$  using the statistical toolbox of MATLAB<sup>®</sup>.

### 3. Results and discussion

#### 3.1. Mass balance of the grape marc and moisture

The fresh grape marc, first separated by using standard sieves with different particle size ranges and then separated by hand, was composed of 19.5% skins and 80.5% seeds.

The moisture content was 59.5% for the grape marc, 59.1% for the skins and 49.1% for the seeds. These data were in agreement with those of [Toscano et al. \(2013\)](#) and [Ribereau-Gayon et al. \(2007\)](#).

#### 3.2. Evaluation of grape seed size distribution

The centrifugal force to which the grape marc was subjected because of the roller gave different results for seed separation using the two considered distances between shaft and bowl.

The mean distribution fittings of the seed areas, derived for each data series of 18, are provided in Figs. 4 and 5 for the Type-A blade and Type-B blade, respectively.

The goodness of fit of all curves was better than 95%, as listed in Tables 1 and 2 for both types of blades.

To determine the machine efficiency, the distributions were subjected to statistical analysis to identify the speed rotation that led to seeds similar to those belonging to the control test.

Fig. 4 shows that the control test had a typical normal distribution; however, when the machine operated with a Type-A blade configuration, bimodal distributions were obtained for all speeds considered. A bimodal distribution means that a fraction of the seeds was destroyed by the blade and their resulting areas were smaller than those of the intact seeds; because of their reduced area, they passed through the

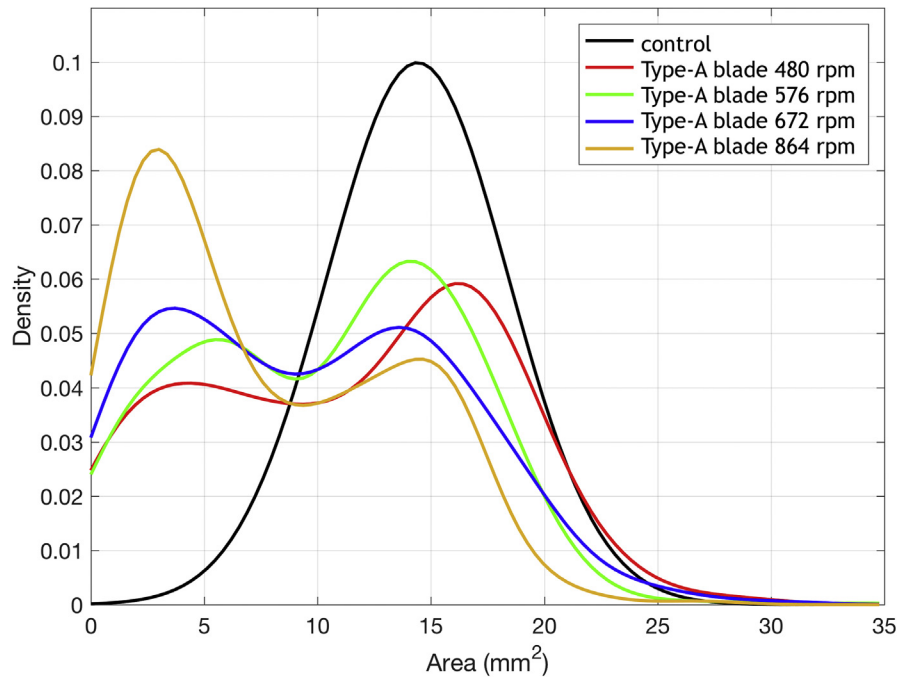

**Fig. 4.** Density distribution of the area of seeds for the different rotating speed using Type-A blade settings.

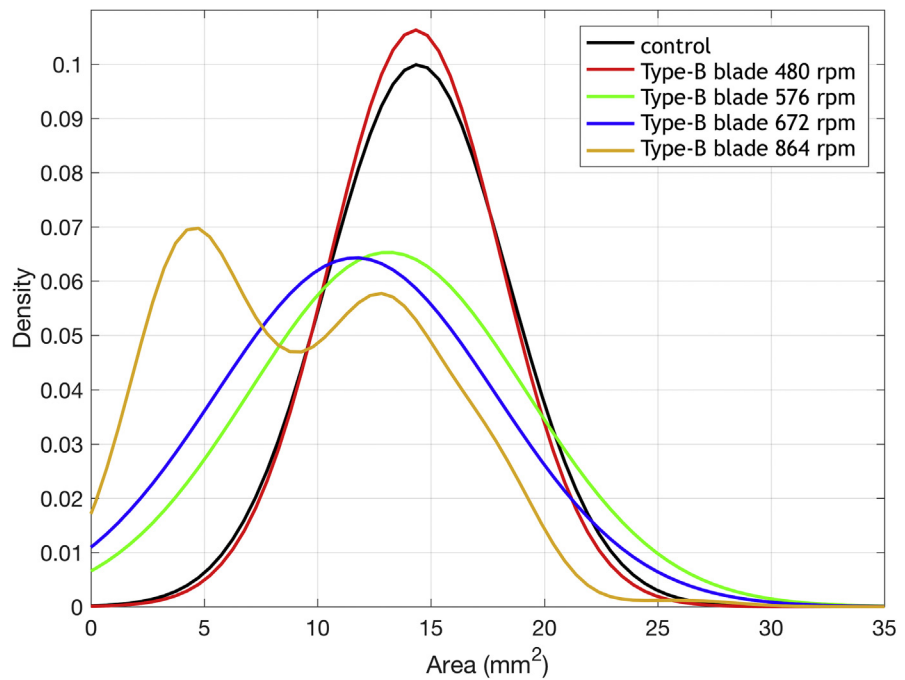

**Fig. 5.** Density distribution of the area of seeds for the different rotating speed using Type-B blade settings.

**Table 1.** Goodness of fit for Type-A blades distributions.

Goodness of fit	Ctrl	480 rpm	576 rpm	672 rpm	864 rpm
SSE	409.80	286.10	640.00	166.40	649.11
R <sub>2</sub>	0.93	0.92	0.94	0.99	0.98
R <sub>2</sub> adjusted	0.91	0.90	0.93	0.99	0.97
RMSE	3.05	8.91	3.70	4.56	11.39

**Table 2.** Goodness of fit for Type-A blades distributions.

Goodness of fit	Ctrl	480 rpm	576 rpm	672 rpm	864 rpm
SSE	409.8	287.4	77.68	6.64	69.11
R <sub>2</sub>	0.93	0.99	0.99	0.99	0.99
R <sub>2</sub> adjusted	0.91	0.98	0.98	0.99	0.97
RMSE	3.05	7.58	3.94	1.15	18.54

bowl holes and reached the fraction of soft marc. As the bimodal distribution is clearly different from the normal one, the data for the Type-A blade will not be analysed or discussed further. These results show that the Type-A configuration must be excluded regardless of the reel rotation speed, because the small distance between blade and cylinder caused excessive breakage of the seeds under all conditions tested. The machine cannot be used in this configuration.

Considering that the seeds areas are described by a normal distribution, the Type-B blade allows the normal distribution of areas to be maintained during operation at 480, 576 and 678 rpm. The highest speed at 864 rpm determined the boundary beyond which the area distribution became bimodal (Fig. 5).

To determine the machine efficiency when the Type-B blade was used, the distributions were subjected to statistical analysis to identify the speed rotation leading to seeds similar to those of the control test. The parameters of the distributions are listed in Table 3. The trial conducted at 480 rpm is described by a normal distribution

**Table 3.** Distribution parameters for Type-A blade data.

Parameter	ctrl	480 rpm	576 rpm	672 rpm	864 rpm
mean (mm)	14.41 ± 0.23 <i>a</i>	14.32 ± 0.37 <i>a</i>	13.10 ± 0.48 <i>b</i>	11.67 ± 0.63 <i>c</i>	9.45* ± 0.41 <i>d</i>
mode (mm)	14.40 ± 0.21 <i>a</i>	14.41 ± 0.23 <i>a</i>	13.22 ± 0.39 <i>b</i>	11.71 ± 0.51 <i>c</i>	12.93* ± 0.71 <i>bc</i>
mode frequency (%)	9.98 ± 0.64 <i>a</i>	10.63 ± 0.58 <i>a</i>	6.53 ± 0.33 <i>b</i>	6.43 ± 0.18 <i>b</i>	5.77* ± 0.22 <i>c</i>
σ (mm)	3.99 ± 0.43 <i>a</i>	3.75 ± 0.14 <i>a</i>	6.11 ± 0.64 <i>b</i>	6.21 ± 0.47 <i>b</i>	-
kurtosis	2.90 ± 0.22 <i>b</i>	3.42 ± 0.44 <i>b</i>	2.89 ± 0.32 <i>c</i>	6.20 ± 2.50 <i>a</i>	-
skewness	-0.55 ± 0.09 <i>b</i>	-0.69 ± 0.05 <i>b</i>	-0.62 ± 0.07 <i>b</i>	0.37 ± 0.40 <i>a</i>	-

Data are represented as mean value ± standard deviation.

Different letters on the same row indicate significant differences ( $p < 0.05$ ).

statistically equal to that of the control. In fact, mean, mode, mode frequency, sigma, kurtosis, and skewness are statistically equal at a  $p$ -level of 0.05. Rotation speeds of 576 and 672 rpm generated seeds that also had a normal distribution; however, the results are statistically different from those of the control and the 480 rpm tests. This suggests that the higher the rotation speed, the more the area distributions tend to move to the left. In fact, the mode value and the mode frequency decrease when shifting from the control test to the 672 rpm tests. In addition, the kurtosis value decreases when the rotation speed increases. Concerning the skewness, the control, 480 rpm, and 576 rpm data are described by left-skewed normal distributions. In contrast, the 672 rpm tests are described by a right-skewed normal distribution. This situation indicates that 672 rpm represents a rotation speed that changes the seed separation capability. When the rotation speed is increased to 842 rpm, the area distribution becomes bimodal, no longer described by a normal distribution. This indicates a disruption in a fraction of seeds.

Use of the type-B blade demonstrated that, by appropriate adjustment of the reel rotation, an optimal rotation speed could be identified. In this case, the optimal rotation speed was 480 rpm.

In Figs. 6a, 6b, 6c, and 6d, comparisons of fitting distributions between Type-A and Type-B blades for each reel rotation speed are shown. For all four rotation speeds, when the distance between the blade and cylinder is small, the quantity of

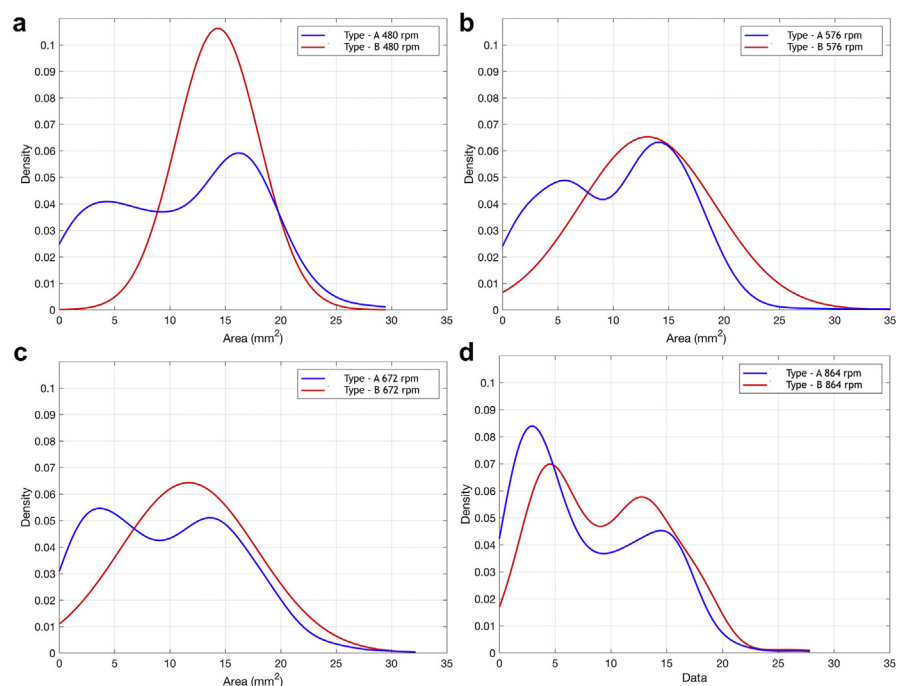

**Fig. 6.** Comparison of density distribution of the area of seeds obtained by Type-A and Type-B blade settings at: a) 480 rpm; b) 576 rpm; c) 672 rpm; d) 864 rpm.

broken grape seeds increases. In fact, all fittings have small-size fractions in percentages greater than those obtained by increasing the distance between blade and cylinder.

Considering the analysis of the data, seed separation was more efficient when the Type-B blade were used compared with the Type-A blades that led to bimodal distributions for all speeds considered.

In addition, the Type-B blade at 480 rpm resulted in the best combination for a good seed separation without the contamination of soft marc by broken seeds.

Finally, Fig. 7 shows the grape seeds of the control test and the seeds obtained by using the machines with Type-B blades at four different reel rotation speeds.

The seeds obtained at a reel rotation speed of 480 rpm (Fig. 7b) are similar in appearance to the seeds obtained in the control test (Fig. 7a). In all the other cases, shown in



**Fig. 7.** Comparison of seeds of the control (a) and the seeds obtained by Type- B blade settings at: b) 480 rpm; c) 576 rpm; d) 672 rpm; e) 864 rpm.

Figs. 7c, 7d, and 7e, seeds appear partially damaged or partially broken; the images confirm the data statistically detected.

Although only one optimal condition was identified (Type-B blade at 480 rpm), the results show that seeds and soft solids could be separated from fresh marc using a centrifugal separator. This result is only a first step in solving the problem. Starting from this step, new prototypes more efficient than the present one could be developed to improve the separation in a quantitative and qualitative manner.

## 4. Conclusions

The separation by centrifugation of grape seeds from fresh marc was possible with the adequate design and regulation of a customised machine.

The study showed the development of an adequate centrifugal separator composed mainly of a perforated cylinder and a reel, and demonstrated that efficient separation the seeds and the soft solids from the fresh marc is possible by adequately adjusting the speed rotation and the distance between the blade and cylinder.

The development of this type of technology will allow the separation to occur directly in the winery in line with the wine production process, and will allow total separation of seeds and soft solids from which components with potential health benefits can be extracted without compromising their health value.

The use of this technology will increase the potential uses of fresh marc. However, future research for a more careful design of the machine (reel and cylinder) is essential to improve separation performance.

## Declarations

### Author contribution statement

Roberto Romaniello, Antonia Tamborrino, Alessandro Leone: Conceived and designed the experiments; Performed the experiments; Analyzed and interpreted the data; Contributed reagents, materials, analysis tools or data; Wrote the paper.

### Funding statement

This work was supported in part by Puglia Region “Guidelines for Research and Experimentation in Agriculture 2012–2014”, SOLBIOGRAPE – Mechanical plant solutions for the enhancement of the bioactive component of the grape marc produced in the wine-making process.



## Competing interest statement

The authors declare no conflict of interest.

## Additional information

No additional information is available for this paper.

## References

Schönnenbeck, C., Trouvé, G., Valente, M., Garra, P., Brilhac, J., 2016. Combustion tests of grape marc in a multi-fuel domestic boiler. *Fuel* 180, 324–331.

Baumgärtel, T., Kluth, H., Epperlein, K., Rodehutschord, M., 2007. A note on digestibility and energy value for sheep of different grape pomace. *Small Rumin. Res.* 67, 302–306.

Bhosle, B.M., Subramanian, R., 2005. New approaches in deacidification of edible oils – a review. *J. Food Eng.* 69, 481–494.

Buglass, A.J., 2011. *Handbook of Alcoholic Beverages: Technical, Analytical and Nutritional Aspects*. John Wiley & Sons, Chichester, UK.

Calabriso, N., Massaro, M., Scoditti, E., Pellegrino, M., Ingrosso, I., Giovinazzo, G., Carluccio, M.A., 2016. Red grape skin polyphenols blunt matrix metalloproteinase-2 and -9 activity and expression in cell models of vascular inflammation: protective role in degenerative and inflammatory diseases. *Molecules* 21 (9) art. no. 1147.

Caputo, A.C., Palumbo, M., Pelagagge, P.M., Scacchia, F., 2005. Economics of biomass energy utilization in combustion and gasification plants: effects of logistic variables. *Biomass Bioenergy* 28, 35–51.

Commission Regulation (EC) No. 555/2008 Laying Down Detailed Rules for Implementing Council Regulation (EC) No. 479/2008 on the Common Organisation of the Market in Wine as Regards Support Programmes, Trade with Third Countries, Production Potential and on Controls in the Wine Sector.

Council Regulation (EC) No. 479/2008 of 29 April 2008 on the Common Organisation of the Market in Wine, Amending Regulations (EC) No. 1493/1999, (EC) No. 1782/2003, (EC) No. 1290/2005, (EC) No. 3/2008 and Repealing Regulations (EEC) No. 2392/86 and (EC) No. 1493/1999.

Dinuccio, E., Balsari, P., Gioelli, F., Menardo, S., 2010. Evaluation of the biogas productivity potential of a few Italian agro-industrial biomasses. *Bioresour. Technol.* 101, 3780–3783.

Ferri, M., Bin, S., Vallini, V., Fava, F., Micheli, E., Roda, A., Minnucci, G., Bucchi, G., Tassoni, A., 2016. Recovery of polyphenols from red grape pomace and assessment of their antioxidant and anti-cholesterol activities. *New Biotechnol.* 33, 338–344.

Gambacorta, G., Faccia, M., Previtali, M.A., Pati, S., La Notte, E., Baiano, A., 2010. Effects of olive maturation and stoning on quality indices and antioxidant content of extra virgin oils (cv. Coratina) during storage. *J. Food Sci.* 75, 229–235.

Gambacorta, G., Trani, A., Punzi, R., Fasciano, C., Leo, R., Fracchiolla, G., Faccia, M., 2017. Impact of ultrasounds on the extraction of polyphenols during winemaking of red grapes cultivars from southern Italy. *Innov. Food Sci. Emerg. Technol.* 43, 54–59.

Greenwood, S., Edwards, G., Harrison, R., 2012. Short communication: supplementing grape marc to cows fed a pasture-based diet as a method to alter nitrogen partitioning and excretion. *J. Dairy Sci.* 95, 755–758.

Hernández, J.J., Aranda-Almansa, G., Bula, A., 2010. Gasification of biomass wastes in an entrained flow gasifier: effect of the particle size and the residence time. *Fuel Process. Technol.* 91, 681–692.

Leone, A., Romaniello, R., Peri, G., Tamborrino, A., 2015. Development of a new model of olives de-stoner machine: evaluation of electric consumption and kernel characterization. *Biomass Bioenergy* 81, 108–116.

Mendes, J.A., Xavier, A.M., Evtuguin, D.V., Lopes, L.P., 2013. Integrated utilization of grape skins from white grape pomaces. *Ind. Crops Prod.* 49, 286–291.

Muhlack, R.A., Potumarthi, R., Jeffery, D.W., 2018. Sustainable wineries through waste valorisation: a review of grape marc utilisation for value-added products. *Waste Manag.* 72, 99–118.

Organisation Internationale of Vine and Wine (OIV), 2017. World Vitiviniculture Situation, Statistical Report on World Vitiviniculture. <http://www.oiv.int/public/medias/5479/oiv-en-bilan-2017.pdf>.

Paradelo, R., Moldes, A.B., Barral, M.a.T., 2010. Utilization of a factorial design to study the composting of hydrolyzed grape marc and vinification lees. *J. Agric. Food Chem.* 58, 3085–3092.

Ribeiro, L.F., Ribani, R.H., Francisco, T.M.G., Soares, A.A., Pontarolo, R., Haminiuk, C.W.I., 2015. Profile of bioactive compounds from grape pomace (*Vitis vinifera* and *Vitis labrusca*) by spectrophotometric, chromatographic and spectral analyses. *J. Chromatogr. B* 1007, 72–80.



Ribereau-Gayon, P., Dubourdieu, D., Doneche, B., Lonvaud, A., 2007. Trattato di enologia 1-Microbiologia del vino, Vinificazioni. Edagricole, Bologna.

Romaniello, R., Leone, A., Tamborrino, A., 2017. Specification of a new de-stoner machine: evaluation of machining effects on olive paste's rheology and olive oil yield and quality. *J. Sci. Food Agric.* 97 (1), 115–121.

Sarkar, N., Ghosh, S.K., Bannerjee, S., Aikat, K., 2012. Bioethanol production from agricultural wastes: an overview. *Renew. Energy* 37, 19–27.

Servili, M., Taticchi, A., Esposto, S., Urbani, S., Selvaggini, R., Montedoro, G., 2017. Effect of olive stoning on the volatile and phenolic composition of virgin olive oil. *J. Agric. Food Chem.* 55, 7028–7035.

Silva, M., Macedo, A., Malcata, F., 2000. Review: steam distilled spirits from fermented grape pomace Revision: bebidas destiladas obtenidas de la fermentación del orujo de uva. *Rev. Agroquim. Tecnol. Aliment.* 6, 285–300.

Spigno, G., De Faveri, D.M., 2007. Antioxidants from grape stalks and marc: influence of extraction procedure on yield, purity and antioxidant power of the extracts. *J. Food Eng.* 78 (3), 793–801.

Torres, J.L., Varela, B., García, M.T., Carilla, J., Matito, C., Centelles, J.J., Cascante, M., Sort, X., Bobet, R., 2002. Valorization of grape (*Vitis vinifera*) by-products. Antioxidant and biological properties of polyphenolic fractions differing in procyanidin composition and flavonol content. *J. Agric. Food Chem.* 50, 7548–7555. ISSN: 1579-4377.

Toscano, G., Riva, G., Duca, D., Pedretti, E.F., Corinaldesi, F., Rossini, G., 2013. Analysis of the characteristics of the residues of the wine production chain finalized to their industrial and energy recovery. *Biomass Bioenergy* 55, 260–267.

Walle, T., Hsieh, F., DeLegge, M.H., Oatis Jr., J.E., Walle, U.K., 2004. High absorption but very low bioavailability of oral resveratrol in humans. *Drug Metab. Dispos.* 32 (12), 1377–1382.

Waterhouse, A.L., Sacks, G.L., Jeffery, D.W., 2016. Introduction to Phenolics, Understanding Wine Chemistry. John Wiley & Sons Ltd., pp. 99–104