

Electronic p-Chip-Based System for Identification of Glass Slides and Tissue Cassettes in Histopathology Laboratories

Wlodek Mandecki¹, Jay Qian¹, Katie Gedzberg¹, Maryanne Gruda^{1,2}, Efrain "Frank" Rodriguez^{1,3}, Leslie Nesbitt⁴, Michael Riben⁴

¹PharmaSeq, Inc., ²Cytosorbents Corporation, Monmouth Junction, ³Weego-Paris Corporation, Westampton, NJ, ⁴The University of Texas MD Anderson Cancer Center, Houston, Texas, USA

Received: 08 October 2017

Accepted: 30 January 2018

Published: 02 April 2018

Abstract

Background: The tagging system is based on a small, electronic, wireless, laser-light-activated microtransponder named "p-Chip." The p-Chip is a silicon integrated circuit, the size of which is $600\ \mu\text{m} \times 600\ \mu\text{m} \times 100\ \mu\text{m}$. Each p-Chip contains a unique identification code stored within its electronic memory that can be retrieved with a custom reader. These features allow the p-Chip to be used as an unobtrusive and scarcely noticeable ID tag on glass slides and tissue cassettes. **Methods:** The system is comprised of p-Chip-tagged sample carriers, a dedicated benchtop p-Chip ID reader that can accommodate both objects, and an additional reader (the Wand), with an adapter for reading IDs of glass slides stored vertically in drawers. On slides, p-Chips are attached with adhesive to the center of the short edge, and on cassettes – embedded directly into the plastic. ID readout is performed by bringing the reader to the proximity of the chip. Standard histopathology laboratory protocols were used for testing. **Results:** Very good ID reading efficiency was observed for both glass slides and cassettes. When processed slides are stored in vertical filing drawers, p-Chips remain readable without the need to remove them from the storage location, thereby improving the speed of searches in collections. On the cassettes, the ID continues to be readable through a thin layer of paraffin. Both slides and tissue cassettes can be read with the same reader, reducing the need for redundant equipment. **Conclusions:** The p-Chip is stable to all chemical challenges commonly used in the histopathology laboratory, tolerates temperature extremes, and remains durable in long-term storage. The technology is compatible with laboratory information management systems software systems. The p-Chip system is very well suited for identification of glass slides and cassettes in the histopathology laboratory.

Keywords: Barcode, biobank, biorepository, identification, microtransponder, radio frequency identification

INTRODUCTION

Over 8 million diagnostic and therapeutic pathology specimens are collected annually at medical teaching institutions alone,^[1] and >100 million tissue specimens are currently stored in large tissue banks and repositories in the United States. These specimens represent a valuable asset for both patient care and research initiatives^[1,2] and are increasingly recognized as the foundation of translational research for the discovery and validation of clinically useful biomarkers and therapeutic targets. Labeling problems have been well documented.^[3] In the pathology setting, labeling error rates ranged from 9.29% without radio frequency identification (RFID) to 0.55% with RFID.

The management of the large numbers of samples mandates a highly reliable and preferably, machine-readable tracking

system. Barcoding is the most popular method for tagging slides and cassettes. One and two dimensional (1D and 2D) barcodes may be printed directly onto the slide or cassette or onto a label that is then applied to the item. However, many challenges have been noted with this technology. The adhesives used on labels can fail on exposure to solvents used for processing tissues, particularly xylene, causing some companies such as Brady (Milwaukee, WI) to implement a dual adhesive/mechanical-embedding system to ensure

Address for correspondence: Dr. Wlodek Mandecki, PharmaSeq, Inc., 11 Deer Park Dr., Suite 104, Monmouth Jct., NJ 08852, USA. E-mail: mandeck@pharmaseq.com

This is an open access article distributed under the terms of the Creative Commons Attribution-NonCommercial-ShareAlike 3.0 License, which allows others to remix, tweak, and build upon the work non-commercially, as long as the author is credited and the new creations are licensed under the identical terms.

For reprints contact: reprints@medknow.com

How to cite this article: Mandecki W, Qian J, Gedzberg K, Gruda M, Rodriguez EF, Nesbitt L, *et al.* Electronic p-Chip-based system for identification of glass slides and tissue cassettes in histopathology laboratories. *J Pathol Inform* 2018;9:9.

Available FREE in open access from: <http://www.jpathinformatics.org/text.asp?2018/9/1/9/228964>

Access this article online

Quick Response Code:



Website:
www.jpathinformatics.org

DOI:
10.4103/jpi.jpi_64_17

permanent label attachment. Direct barcode printing systems are available from Thermo Scientific (Waltham, MA) and General Data Company (Cincinnati, OH). While preparing the labeled slides and cassettes appears straightforward, the process is often fraught with problems ranging from clogged or dry markers to inks smearing before setting. Direct barcode printers (which can print on polypropylene or glass) are typically very costly, putting them out of reach of many facilities.

An alternative tagging method that employs RFID technology has made significant inroads into healthcare to improve the identification and traceability of a variety of medical items. Several manufacturers offer large adhesive RFID label systems^[4,5] that are attached to the exterior of sample containers. While these methods have found applications in tagging hospital equipment, blood bags, and other such items, advancement in histopathology applications has been slow.

In histopathology laboratories, the approach involves attaching an RFID tag to a glass slide or a tissue cassette. This has been extensively tested and reviewed,^[3,6-10] and several benefits, as well as shortcomings, were identified. While RFID allows for tracking improvements, such as decreased labeling errors, the ability for nonline of sight reads, and increased reading range compared with barcode systems, current systems are plagued by large tag sizes, ill-shaped tags, and high costs. Additional concerns include RFID tag integrity with exposure to various chemical and variable temperature conditions typically a part of the histopathology process. Current systems also struggle with asset discrimination required for scanning given the proximity of pathology assets during production, usage, and in particular, storage. Finally, barriers exist to further improvement in the applicability of RFID technology to histopathology, such as the requirement for a sufficiently large antenna to support wireless communication and RF power limitation. For all of these reasons, a new solution is needed.

PharmaSeq has pioneered a tagging and tracking system that is based on the laser light-activated p-Chip microtransponder^[11] [Figure 1]. The p-Chip system has been employed recently for tagging cryovials in biobanks and biorepositories,^[12] laboratory mice^[13] (a commercial system is available), insect pins in entomology collections,^[14] as well as in studies of the social behavior of ants^[15,16] and bees.^[17] A smaller, 250 μ version of the p-Chip was implanted into a frog embryo.^[18] In addition, p-Chips have been used as solid phase particles in many types of bioassays, proteomics, and genomics.^[19-22] The p-Chip was even used as a part of a mechanical assembly of a microgripper.^[23]

In histopathology applications, the system is comprised p-Chip-tagged glass slides and cassettes, a custom benchtop p-Chip ID reader that can accommodate both objects, and an additional reader (the Wand), with an attachment for reading IDs of glass slides stored vertically in drawers. The p-Chip tagging is done by the manufacturer or supplier of the slides

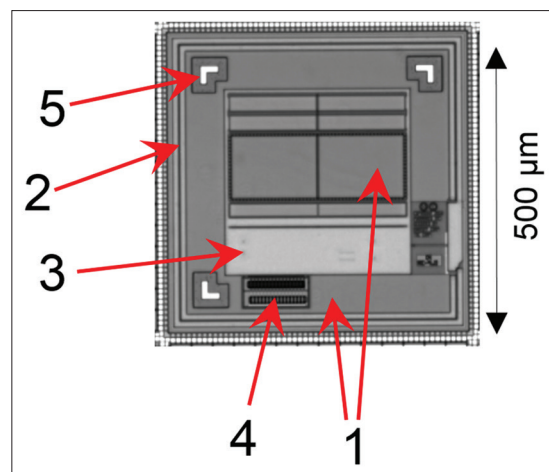

Figure 1: Photograph of a p-Chip. (1) photocells; (2) antenna; (3) logic circuitry; (4) memory; and (5) registration marks

and cassettes themselves. The purpose of this paper is to describe key properties of the p-Chip system for tagging and tracking glass slides and tissue cassettes in the histopathology laboratory. We also present early results from testing of the system using protocols developed for the histopathology laboratory and discuss usage options.

MATERIALS AND METHODS

p-Chip

The p-Chip^[13] is a monolithic (single-element) integrated circuit ($600 \mu\text{m} \times 600 \mu\text{m} \times 100 \mu\text{m}$) that can transmit its identification code through radio frequency (RF) [Figure 1]. It is composed of photocells, clock signal extraction circuits, a logical state machine, a loop antenna, and a 64-bit memory currently supporting over 1.1 billion possible ID codes. The photocells, when illuminated by a pulsed laser, provide power to the electronic circuits on the chip with $\sim 10\%$ efficiency. The chip transmits its ID through modulated current in the antenna. The varying magnetic field around the chip is received by a nearby coil in the reader, and the signal is digitized, analyzed, and decoded. p-Chips are manufactured on silicon wafers in foundries, using CMOS processes similar to those used in the manufacturing of memory chips and computer processors. Wafers receive postmanufacturing treatment consisting of laser encoding, passivation, thinning, and dicing to yield individual p-Chips. The p-Chip surface is made of silicon dioxide, which is deposited as a final passivation layer. Each p-Chip is unique with no duplicate IDs programmed.

The stability of the RF transmitting functions of p-Chips is exceptional in a wide variety of aqueous solutions and solvents. They are very stable in most aqueous solutions (half-life >3 days in piranha solution: 20% H_2SO_4 , glacial acetic acid and 20% trifluoroacetic acid), moderately stable in basic solutions (10% NaOH half-life of about 1 day) and very stable in all of the organic solvents tested (half-life >3 days in toluene, pyridine, acetonitrile, dimethylformamide, chloroform, and acetone). In addition, p-Chips have excellent temperature

stability: 100% were able to retain RF activity after incubation at well above 200°C for 8 h ($n = 100$), repeated immersion ($\times 10$, 100 chips) in liquid nitrogen (-196°C), and 2000 autoclave cycles (4 min each at 121°C). p-Chips have lifetimes of many years at room temperature (similarly to computer chips) or when frozen at -20°C and -80°C . The data support the suitability of p-Chips to applications in histopathology laboratories where they are exposed to varied environmental conditions.

Wand

The ID reader^[13] (wand) is a key element of the assembly used to read the ID of slides and tissue cassettes stored in drawers. It is a hand-held device connected to a standard Windows PC, laptop or tablet and is capable of reading the serial number (ID) of individual p-Chips [Figure 2]. The wand is USB-powered and contains a USB 2.0 transceiver microcontroller, a field programmable gate array (FPGA), power converters and regulators, a laser diode with the programmable current driver, an optical collimation/focusing module, and a tuned air coil pickup with a high-gain, low-noise differential RF receiver. The laser emits an average of 60 mW of optical power modulated at 1 MHz at 658 nm wavelength when reading a p-Chip ID. The ID is read when the p-Chip is placed within suitable proximity (<10 mm) from the reader. The waveform generated provides the data clock used for synchronization of the transmitted ID data bits. The timing of the pulse groups is set so that the duty cycles and average power levels fall within requirements for registration with the FDA as a Class 3R laser device, meaning that protective eyewear is not necessary. The components in the wand can be easily configured into a family of dedicated readers for different form factors such as flat (e.g., glass slides) or round (e.g., sample tubes) objects.

The resulting ID readout from the p-Chip is rapid (<0.01 s) and is reported on the PC or tablet using the PharmaSeq-developed software. We have demonstrated in internal validation studies the robustness of the wand reading capability as it will read p-Chips under challenging conditions, such as through a sheet

of white paper, blue-colored glass (~ 1 mm thick), or a sheet of transparent plastic laminate. We have also shown the p-Chip ID readout through mouse skin.^[13]

Other

Glass slides were purchased from Azer Scientific, Corning Micro Slides or Fisher Scientific (Fisherfinest Premium Cover Glasses). Tissue cassettes were obtained from Simport and Leica-Microsystems IP. Chemical solvents were purchased from Sigma Aldrich.

Glass slide testing procedure

Groups of 10 slides (which were prepared as described in the results section) were placed inside of slide staining wells and then fully immersed in undiluted chloroform, isopropanol, ethanol, methanol, dimethylformamide, water, and xylene (one chemical per well). The slides were removed from the chemical baths at time points of 4 and 24 h, with the exception of xylene, which was removed only after 48 h.

Tissue cassette testing procedure

Groups of three p-Chip-tagged cassettes (prepared as described in the Results section) were placed inside of glass jars and then fully immersed in undiluted xylene, ethanol, and Cal-Ex Decalificier (Fisher, CS510-1D), as well as 10% neutral buffered formalin (one chemical per jar). The cassettes were removed from the jars at time points of 24 and 48 h.

RESULTS

Attachment of p-Chips to glass slides

First, a decision needed to be made regarding the location of the p-Chip on the slide. Options included the top or bottom surfaces, and two types of edges, long and short. Placement on the top and bottom large surfaces would reduce the work area, and was not pursued. Of the two edges, the short side was preferred since reading of the slide by a dedicated ID reader (see below) is facilitated if the p-Chip is located on the short edge. In addition, knowing that in many popular

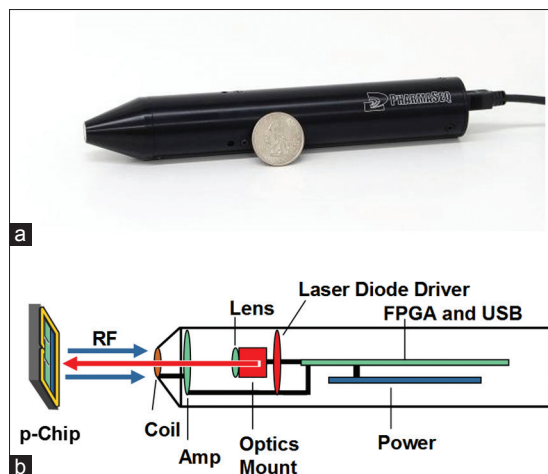

Figure 2: PharmaSeq's ID reader for p-Chips (Wand). (a): Photograph of a Wand. (b): Design principle

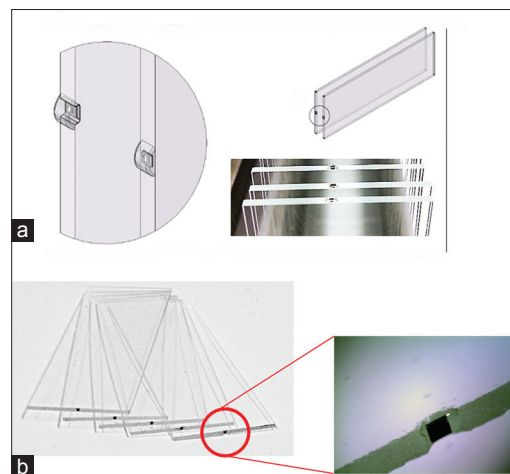

Figure 3: Approaches to affix p-Chips to glass slides. (a) Placement into a groove on the edge of the slide. (b) Gluing on short edge of the slide

drawer-based slide storage systems, stacks of glass slides are maintained in a vertical orientation with the short edge up, having the p-Chip on the short edge would permit reading of the ID without removing or changing the position of the slide. Given all possible locations on the short edge, the center position was chosen as most convenient for reading IDs of slides stored vertically in drawers [Figure 3].

The main challenges present in attaching p-Chips to glass slides are the small surface area of the chip for attachment and the large difference in the thermal expansion coefficient between silicon (COE 37) and glass (COE 89). A number of different strategies were tested for stable adherence of the p-Chips.

Different formulations of solder glass (Corning), in particular types 7572 and 7575, were applied to the slide edge and p-Chips placed within the slurry. The slides were then baked at temperatures up to 450°C to set the solder glass. The p-Chips retained readability, however, the solder glass became more opaque than desirable, and given the difficulty in handling the material, it was deemed not acceptable for this application. Similarly, glass transfer tape and glass frit (Vitta Corporation) were considered, but a suitable material could not be identified.

Next, several types of adhesives were evaluated for this application before an ultimate method was selected. Norland Optical Adhesive 61 (“NOA 61”), ultraviolet curable, liquid photopolymer could be readily applied, but this did not demonstrate sufficient chemical stability. Consultations with Diamat, Inc. and 3M did not yield an epoxy that could handle the solvents typically used in tissue processing and staining. Ultimately, a two-part epoxy from MasterBond (EP41S-HT), with outstanding resistance to organic solvents and the ability to withstand temperatures from -50°C to 175°C, was selected. To improve adhesion, the available surface area was increased by creating a 1 mm deep groove in the center of the edge of the glass slide. As such, notched slides were prepared by Specialty Glass Products (Willow Grove, PA), and p-Chips

were attached to both notched and unnotched slides with EP41S-HT [Figure 3].

Attachment of p-Chips to tissue cassettes

The most desirable position for p-Chip attachment was determined to be the middle of front edge [Figure 4]. At 100 µm in height, the p-Chip is compatible with the 0.91 mm wall thickness at the front of a common cassette (Simport) so that the embedding procedure should not significantly weaken the wall. The p-Chips were placed using a vacuum chuck incorporated into a modified soldering iron-based on a standard Weller model WSD80.

We designed a custom tip with an internal air/vacuum channel to be mounted on the soldering iron (described above) connected with a small (5–7 psi) vacuum pump [Figure 5]. The soldering iron can be fixed to a bench frame for manual tagging of the cassettes or fixed on a robotic quill for robotic placement of the p-Chips. The procedure involves first moving the vacuum tip approximately 0.2 mm above the p-Chip which is oriented to position the electronic circuit side-up. When vacuum is applied to the soldering tip, the p-Chip will adhere tightly to the tip of the soldering iron when the vacuum is applied.

Cassettes are loaded into the fixture one at a time [Figure 6]. The soldering iron tip holds the p-Chip in place and simultaneously heats it above 200°C. The coupled tip with the p-Chip then moves to the center of the front edge of the cassette and thermally embeds the chip into the plastic. As the fixture returns to its original position, the p-Chip remains within the wall of the cassette, and 7 psi positive pressure passes through the air channel to clean the tip. Larger quantities of cassettes can be processed robotically using a specially designed holding rack [Figure 7].

After embedding, the p-Chips were sealed with a drop of epoxy on top of the chip. All p-Chips were confirmed to be readable following this step. Extensive testing gave no indication that attaching p-Chips to cassettes reduced the cassettes’ structural integrity.

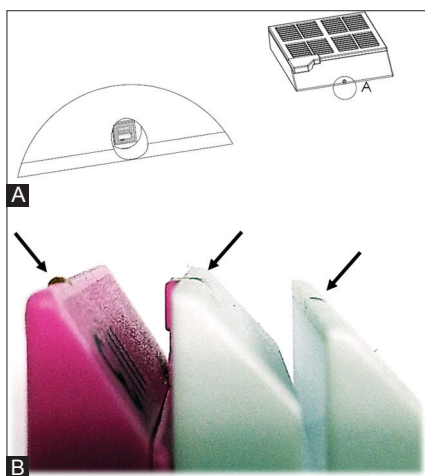

Figure 4: p-Chips attached to tissue cassettes. Panel A: (a) schematic drawing. Panel B: Picture of p-Chip-tagged cassettes. Arrows show the location of the p-Chip

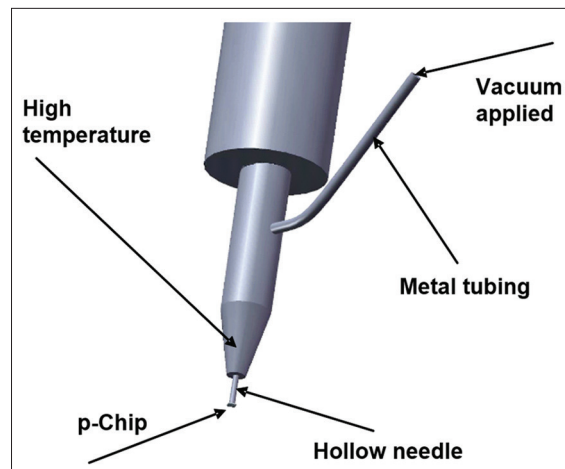

Figure 5: Custom soldering iron tip

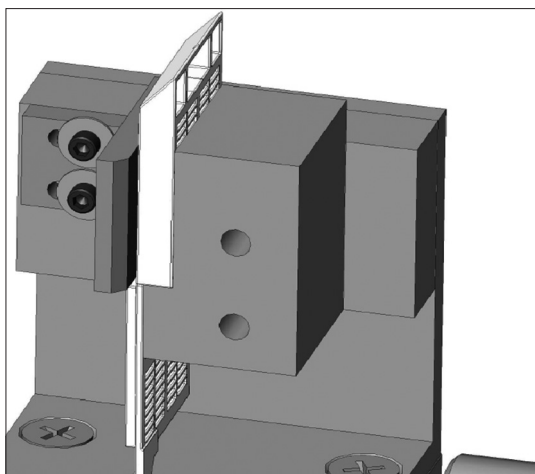

Figure 6: Fixture for attaching p-Chips to tissue cassettes

More than 1000 cassettes were tagged with p-Chips during this project.

Semi-automated attachment of p-Chips to glass slides

The most desirable position for p-Chip attachment on glass slides (standard dimensions: 25.4 mm × 76.2 mm × 1 mm) was deemed to be the middle of the short edge [Figure 3]. p-Chip width (600 μm) is compatible with the 1 mm height of a standard slide in that there is no risk of chip “overhang,” and the embedded p-Chip can be easily placed in the center of the short edge. For this application, we designed a device that holds the slides in such a way that two consecutive slides form a 90° “letter L” [Figure 8]. The holder creates a 1 mm space between slides prepared for p-Chip tagging, which is necessary to prevent glue contamination and linkage between the slides. This holder is appropriate for both manual and robotic tagging of slides. The manual tagging procedure involves dispensing a small amount of prepared adhesive (Epoxy EPOCAST 88103, Huntsman) in the center of the slide’s short edge while the slides are mounted on a rack. Dispensing is performed with a toothpick dipped into a well of epoxy. After the p-Chip is placed on the epoxy-coated slide, an additional small amount of adhesive is used to cover the p-Chip. Then, the rack is turned by 90°, and the group of slides perpendicular to the initial group undergoes the same procedure. The epoxy handling cure time is approximately 2 h, and full cure time takes 24 h at room temperature and 3 h at 93.3°C. Robotic tagging is performed using a similar procedure with the exception that p-Chip placement is performed robotically [Figure 9]. After curing of the epoxy, the p-Chip IDs of all slides are logged with the histo-reader to ensure proper function.

More than 1000 glass slides were tagged with p-Chip during this project.

ID reader for slides and cassettes (“histo-reader”)

Due to cost and usability requirements, we adopted the design principle that a single ID reader device would accommodate both slides and cassettes. The electronic and optical components of the existing reading wand were spatially modified in a new

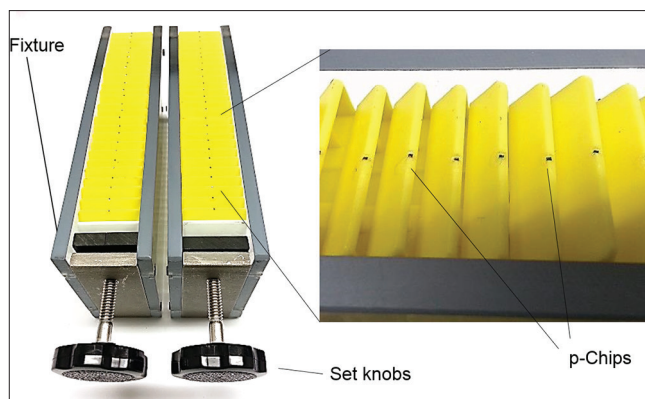

Figure 7: Photographs of specially designed tagging fixture for placing p-Chips on tissue cassettes

compact enclosure to create a form factor suited for slides and cassettes. The resulting histo-reader is shown in Figure 10.

The key element of the histo-reader is a newly designed Laser Receiver Module [Figure 11]. The module provides both the p-Chip activation function, as it contains a laser diode, and the RF signal receiving function, as it contains a coil (an antenna) and an RF amplifier. The signal analysis component is provided by two printed circuit boards identical to those in the standard wand reader and mounted on the back of the enclosure. A special form factor with an IR sensor was design to allow both slides and cassettes be read by passing them through a “beak-like” groove on the face of the device. The role of the sensor placed within the “beak” is to detect a slide or a cassette and activate the laser diode. Without this sensor, the laser would exist in a constantly active state, contributing to the wear of the device. To prevent movement of the histo-reader as a slide or cassette are passed through the “beak,” a metal weight block is placed on the bottom of the case, lowering the center of gravity. Six screws seal the enclosure to the base/backplate.

Slides or cassettes are read in a swiping motion, from one side to the other. Since reading is rapid, the system is not dependent on the speed of the swiping motion. The p-Chip ID appears on the screen of an attached laptop or tablet in the software application.

Software

PharmaSeq provides “p-Chip Reader” software with each reading device. The program receives and processes the data from each slide and cassette as it is read. p-Chip Reader software interfaces with an embedded controller in the histo-reader that controls an FPGA within the reader that decodes the ID and if desired passes it to any program running on a Windows device. The ID can be displayed directly in the p-Chip Reader interface or as a simulated keyboard entry in desktop programs, such as Excel or Access for small collections or into comprehensive enterprise systems, such as laboratory information management systems (LISs or LIMS) for larger institutions.

ID reader for stacks of glass slides in storage drawers

An attachment for the ID reader was constructed to facilitate reading many slides stored vertically in collections in

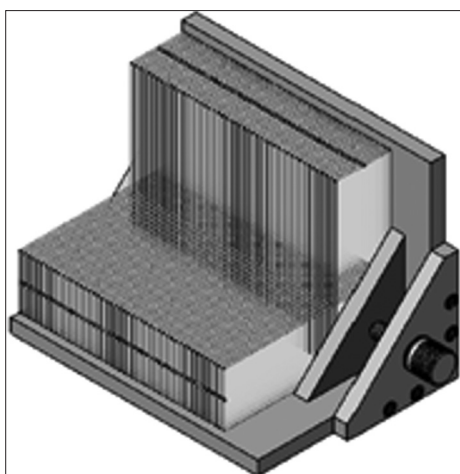

Figure 8: Tool to hold glass slides for tagging

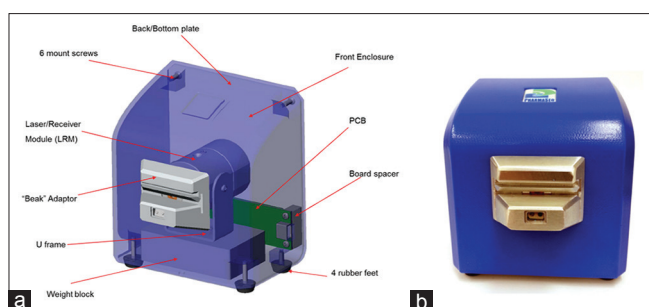

Figure 10: Histo-reader for reading p-Chip IDs on microscope glass slides and tissue cassettes. (a): See-through view. (b): Photograph of histo-reader

drawers [Figure 12 a-c]. This enables reading stacks of slides or cassettes, aiding the rapid location and retrieval of desired samples. This also addresses one of the key difficulties in larger facilities: retrieving slides that are stored in high-capacity slide drawers [Figure 12c]. Such storage drawers are made by a number of manufacturers in a variety of sizes and storage capacities, limiting the usefulness of any system dependent on drawer dimensions. However, in the vast majority of such systems, one or two rows of vertical slides are held back-to-back in such a way that a slim guide will allow the ID reader to roll across an entire row of slides [Figure 12c]. Movement is similar to that of a skateboard with four small bearings coated by silicone rubber, preventing damage to the slide edges during the scan. The guide has a narrow (0.5 mm) slit that allows the wand to activate the p-Chip on one slide at a time. There are two side walls to make sure that the laser beam illuminates the center of the edge of the slides in the drawer.

Storage drawer reader Results

Unprocessed groups of 70 notched slides and 70 unnotched slides were positioned in a standard archival drawer stacked tightly, back-to-back, for testing [Figure 12c]. The tray reader with ID reader attached was then rapidly rolled over the slides, and the IDs were recorded. A total of 12 group read tests were done and an average of 60 of 70 slides in each group were

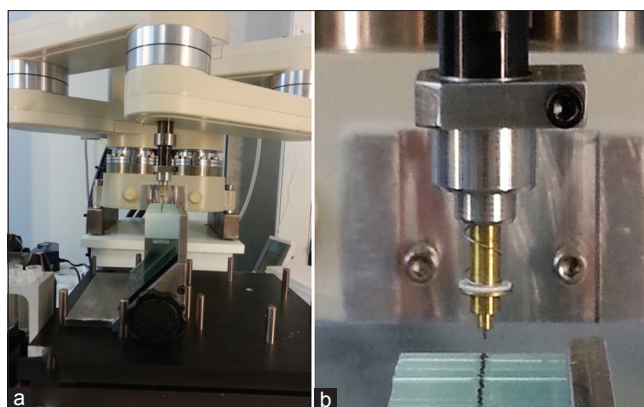

Figure 9: Photographs describing p-Chip placement on slides. (a) Overview of pick-and-place robot. (b) Close-up of vacuum chuck and tagged slides

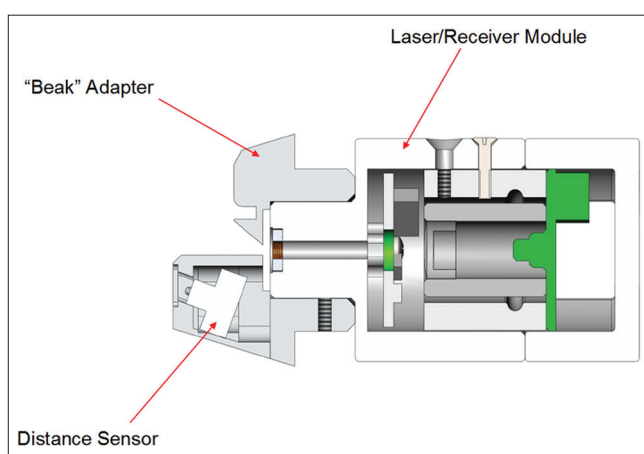

Figure 11: The laser module with an adapter reader

logged successfully. In one instance, all 70 slides were read. The average reading rate for notched slides was slightly better than for unnotched slides (63/70 over 56/70). The slide read rate is at least 10 slides per second. In addition, a prototype version of the p-Chip reader software was written that generated a unique audible tone when a specific searched-for ID was read, enabling exceptionally fast recovery of desired stored slides.

Furthermore, another benefit of the PharmaSeq wand design is the ability to use the reader to read p-Chip-tagged glass slides stored in the commonly used slide folders (trays) as shown in Figure 13.

Testing of tagged slides and cassettes after processing Slides

First, a total of 20 slides (10 with a notch on the short edge accommodating the p-Chip and 10 without) were stained according to a standard H&E staining procedure and read with the ID reader. Each of the 20 slides was scanned successfully on the first attempt. p-Chip-tagged slides were then placed inside of slide staining wells and then fully immersed in chloroform, isopropanol, ethanol, methanol, dimethylformamide, water, or xylene (one chemical per well). The slides were removed



Figure 12: Slide tray attachment for ID reader. (a) Design. Photos of: (b) Slide drawer guide (“skateboard”) for ID reader; (c) Demonstration of reading the IDs of slides stored in a high capacity drawer

from the chemical baths at time points of 4 and 24 h, with the exception of xylene, which was read only at 48 h. The p-Chips test after soaking slides in all of the solutions except the water bath yielded IDs with full accuracy (10 of 10 for each chemical). The p-Chips were completely impervious to the agents they were subjected to 10 of 10 slides placed in chloroform read properly at a 24 h time point. Slides left in water showed 10 of the 10 p-Chip-tagged slides read at 4 h, while 9 of the 10 read at 24 h. However, the single errant chip did produce a proper ID but had become dislodged from the slide.

Cassettes

A total of 140 p-Chip-tagged cassettes were tested by subjecting groups (11–43 cassettes each) to one of four processing protocols (Biopsy, Breast_Biopsy, Placed_in_Decal_Solution, Surgical) with subsequent embedding in paraffin wax. 13 unprocessed cassettes served as the control group. Of the 138 cassettes that were successfully read, 135 cassettes were read during the first pass. It was determined that two cassettes (one from the biopsy and one from the Breast_Biopsy processing protocol) could not be read due to an excessive layer of paraffin on the cassette’s edge containing the p-Chip.

Properties of tagged cassettes

Simport Unissette (Market Lab 7018-wh) and Leica-Microsystems IP (cassettes 38440208) with embedded p-Chips were tested for resistance to xylene, ethanol, methanol, 10% neutral buffered formalin, and decalcification solution (1.3 N HCl, 3 mM EDTA) for 24 h, 48 h, and 72 h.^[24] The p-Chips were fully able to withstand all the exposures except the decalcifying solution. It is known that strong acids and strong bases will etch glass and similarly damage silicon chips.

Testing of automated processing

A total of 100 p-Chip-tagged tissue cassettes and 100 p-Chip-tagged slides were sent to a contractor, AML Labs, Inc., (Baltimore, MD), for automated processing and staining respectively.

The p-Chip-tagged cassettes were placed inside of glass jars and then fully immersed in either undiluted xylene, ethanol, Cal-Ex Decalificier (Fisher, CS510-1D) or 10% neutral buffered formalin. The cassettes were removed from each of the jars at 24 and 48 h.

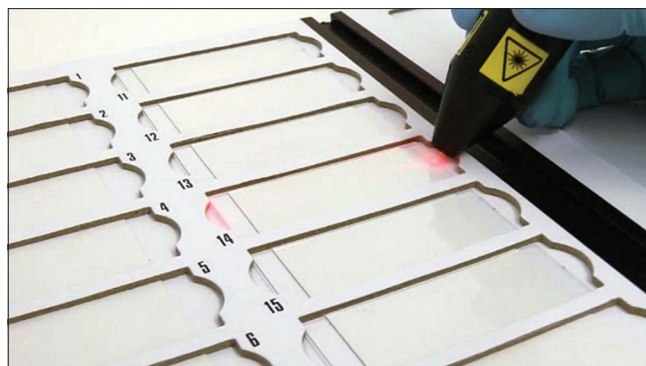

Figure 13: The wand is used to read p-Chip IDs of tagged glass slides placed in slide trays

The p-Chips mounted on slides that were placed in undiluted xylene, ethanol, and 10% neutral buffered formalin were read with full accuracy (3 of 3 for each chemical). They were able to withstand the chemical treatment. Three of the 3 p-Chip-tagged cassettes placed in Cal-Ex Decalificier (Fisher, CS510-1D) read at 24 h, while 2 of the 3 read at 48 h. Note that, most calcified tissues are left in decalcifier for less than the 24 h used in this study.

In each of the above two cases, 99 of the 100 mounted chips were readable.

Testing of the slide tray reader at PharmaSeq

The slide tray reader has been evaluated with several manufacturers’ 6-drawer-type stacked cabinet systems (Thermo Fisher, Phoenix Metal Products) as well as an extremely large custom filing system at MD Anderson Cancer Center. In conjunction, p-Chip Reader software was modified so that a particular slide among a stack of glass slides could be identified based on its ID. The row of slides was scanned with the ID reader. All 76 IDs were read in one pass in ~7 s. Next, a specific ID was entered into the “find ID” field of the prototype p-Chip Reader software, and an audible tone was emitted when the desired slide was read.

DISCUSSION

We describe an innovative and robust system for tagging microscope glass slides and tissue cassettes in the histopathology laboratory to be used as part of a functional asset management system. However, any laboratory in which slides, cassettes or similar products are used, would benefit from the described approach. The approach relies on unobtrusively attaching or embedding an electronic chip, called a “p-Chip.” The p-Chip provides an unalterable ID to the asset that can be retrieved, at any time during laboratory processing or while in archival storage. A custom p-Chip ID reader has been designed to read both slide and cassette assets. The ultra-small size of the p-Chip (600 μm \times 600 μm \times 100 μm) makes it virtually unnoticeable by casual visual inspection or tactile detection.

The unobtrusiveness of the p-Chip tag makes it ideal for many applications since the tag does not interfere with normal use

of the slides or cassettes, and does not impede any biological or biochemical procedure to which the slides or cassettes are subjected to. In particular, histological staining procedures and tissue processing in the cassettes are unaffected. We have tested that the p-Chip and its electronic properties (the storage and transmission of the ID) are not affected by the procedures.

p-Chip tagging does not affect the usable flat areas on both slides and cassettes. Thus, other means of identification to which the laboratory is accustomed to can continue to be used. Two common examples of such widely used methods are pen marking or barcoding.

The p-Chip features enable a high level of security. p-Chips contain an ID number that cannot be altered. All other information related to the sample container is stored in a secure database. Thus, nothing about the sample can be determined from the ID of the object itself, contributing to data security. The linkage of a p-Chip's ID to a specimen is done through the database. Depending on the LIMS or LIS system and the organization of the laboratory, multiple types of data can be linked, in particular, dealing with workflow, personnel performing certain tasks, sample source, and description or the results of the analysis.

Tracking and identifying slides

Tagging with p-Chip results in the permanent placement of an electronic tag on the short edge of glass slides, providing a means of not only tracking slides throughout the "life-cycle" of usage from creation to the file room but also importantly, provides tracking and identification of the slides while in archival storage. Most commercially available slide storage systems, such as Thermo Fisher Scientific, Boekel Scientific, and Tissue Tek, have removable drawers with one or two rows of slides held back-to-back and a six drawer unit which generally holds up to 4500 slides.^[25] These units are frequently stacked to expand capacity. While efficient from space to capacity function, the use-case of locating any one particular slide or set of slides remains a tedious and manual process, which generally entails lifting each slide up to read the label on its front to confirm that the correct slide has been located. While this endeavor is tolerable with a well-organized slide drawer, often these archives are difficult to maintain, and slides get misfiled by accident resulting in an extended effort to locate the correct assets. The ability to identify p-Chip-tagged slides without having to pick each slide up while would make this process much more efficient and beneficial.

While not all slides in the drawer were typically read, often due to the off-center position of the slide in the drawer, future drawer geometrical design can be developed and ways to align them so that all p-Chips can be read. The precise identification of the slide could be aided not only with a beep (as described) but also with the intense illumination of the slide by the Wand positioned over the slide after needed adjustments are made to the software.

The clinical laboratory improvement amendments of 1988 stipulate that accredited laboratories must retain paraffin tissue

blocks for a minimum of 2 years and histopathology slides for at least 10 years from the date of examination.^[26] Some states impose further regulations requiring pathology specimens to be retained for 20 years.^[1] The importance of specimen retention is illustrated by the Veterans Health Administration handbook (2008), which states that full identification is required for any anatomic pathology material and the chain of custody should be preserved for any material sent to another facility for medical-legal examination. In addition, representative glass slides on suspicious or positive cases should be retained for at least 25 years. Digitization of pathology slides can address some of the physical resource sharing issues; however, it is not likely to replace the requirement to archive physical assets due to the technological hurdles associated with the enormous file sizes generated.^[27] As a result, even moderately busy pathology groups end up with vast archives of slides that need to remain organized and accessible for slide retrieval. This has become even more important in the age of precision medicine as we find ourselves pulling these slides to perform molecular tests on tumors to facilitate targeted therapy. The ability to easily read IDs of p-Chipped slides more efficiently without having to redesign the storage cabinets has enormous benefit to organizations.

Comparison with barcoding

Barcoding is the most widely used identification method for slides and cassettes due to its simplicity and low cost. Nevertheless, there are disadvantages.^[9,28] The barcodes can be either damaged or covered with substances (such as paraffin) during procedures. The labels may not adhere properly during staining procedures. The cost of printing barcodes directly on the slides tends to be substantial. Finally, the position of the barcode on the flat surface adjacent to the tissue limits the ability of a line of sight reader to identify the slide when placed vertically in the storage drawers.

Comparison with radio frequency identification-based tagging approaches

While RFID-based tracking systems show potential for applicability in the laboratory, several attempts to use for glass slides and tissue cassettes have not been successful, as described in several recent publications.^[3,5-8,10] Traditional RFID tags are rather impractical because of their large size, high cost in relation to the cost of glass slides and cassettes, and inability to resolve conflicting IDs emanating from multiple tags on closely stored items. PharmaSeq's method of powering each chip by a tightly focused laser beam allows specificity of physical addressing, i.e., addressing a dense array of tags in proximity one tag at a time. This approach is difficult with conventional RFID methods as multiple tags in proximity will attempt to communicate simultaneously, mutually interfering with one another and preventing reading. This is known as "RFID tag collision." An RF signal is only emitted from p-Chips that are actively illuminated by the laser, allowing precise positional specificity that can be applied when reading a stack of slides.

Relevance to cancer research

Tissue and cytological based diagnostic testing serves as the gold standard for cancer diagnosis. From a biopsy or cell smear pathologists look for evidence of cancer, its type, stage, and the degree of tissue infiltration. This process is highly dependent on the accurate registration of specimens with their proper patient identification through numerous stages of processing, and it has little to no tolerance for error. Yet, positive identification of clinically annotated tissues throughout the various handling steps is challenging due to the extreme temperature and chemical conditions used. Inks and adhesive labels are often unreliable in the solvents used to prepare formalin-fixed paraffin-embedded tumor and normal tissue samples. In addition, the ability to obtain sample identification without warming snap-frozen (-86°C or colder) samples prepared for cryosectioning increases the quality of the sample and extends its useful lifetime.^[3,7-9] The use of p-Chip-tagged slides and tissue cassettes should directly advance the National Cancer Institute Office of Biorepositories and Biospecimen Research mission by dramatically improving the reliability of sample tracking throughout processing, storage, distribution, analysis, and redistribution stages.

p-Chip tagging of microscope glass slides and tissue cassettes presents many advantages to the histopathology laboratory, improves on many features generally associated with barcoding and provides technology analogous to RFID (though not identical to RFID), with many benefits generally associated with RFID. It is anticipated that further studies will be done in the future to test the robustness of p-Chip tagging in actual use in the histopathology laboratory.

Additional comments

It was indicated that the tray reader form factor could be modified to accommodate imperfect geometries and close-spaced groups of slides. Future design improvements are described in this proposal [Figure 10]. It was also indicated that an improved ID reading capability would be beneficial. This has been addressed in several sections of this proposal through improvements in the ID reader design, p-Chip design, development of a new stationary reader, and modification of the tray reader. We demonstrated that p-Chips embedded in cassettes and slides survive typical processing.

The system described is a prototype. Testing was done on small sets of slides and cassettes, and the causes of errors have not been thoroughly investigated. Inability to read certain cassettes is due to the material covering the cassettes. The main point we want to make is that technology exists for tagging slides and cassettes in the histopathology lab.

The cost associated with having of a p-Chip on a slide or cassette is low (p-Chips cost one to two cents each, in volume) compare with benefits. The expectation is that laboratories will more than recover the added expense through gained workflow efficiency with pretagged products and the increased value derived from reliably tracked and identified archived samples. The new products should reduce the time required to perform

searches in all sizes of collections, and also to systematically organize those collections.

The nature of the p-Chip tag does not prohibit the use of concurrent identifiers to satisfy regulations. For example, they can also be used with barcoded labels if desired.

Acknowledgments

We thank Dr. Richard G. Morris for reviewing the manuscript and his thoughtful comments. The study design, data collection and analysis were supported by a grant from the National Institutes of Health (1R44CA163008 to WM).

Financial support and sponsorship

Nil.

Conflicts of interest

PharmaSeq, Inc., provided support in the form of salaries for authors WM, ZQ, KG, MG and ER. The PharmaSeq authors own equity in the company. WM, MG, JQ and ER. are the inventors on a pending U.S. Patent Application Number US 13/239,779 titled "Tagging of Small Containers for Biological and Chemical Samples with Light-Activated Microtransponders." JQ and WM are the inventors on a pending U.S. Patent Application Number US 62/286,001 titled "Microchip Affixing Probe and Method of Use."

REFERENCES

1. Eiseman, Elisa and Susanne B. Haga. Handbook of Human Tissue Sources: A National Resource of Human Tissue Samples. Santa Monica, CA: RAND Corporation, 1999. Available from: https://www.rand.org/pubs/monograph_reports/MR954.html. Also available in print form. [Last accessed on 2018 Feb 09].
2. Eiseman, Elisa, Gabrielle Bloom, Jennifer Brower, Noreen Clancy, and Stuart S. Olmsted. Case Studies of Existing Human Tissue Repositories: "Best Practices" for a Biospecimen Resource for the Genomic and Proteomic Era. Santa Monica, CA: RAND Corporation, 2003. Available from: <https://www.rand.org/pubs/monographs/MG120.html>. Also available in print form. [Last accessed on 2018 Feb 09].
3. Francis DL, Prabhakar S, Sanderson SO. A quality initiative to decrease pathology specimen-labeling errors using radiofrequency identification in a high-volume endoscopy center. *Am J Gastroenterol* 2009;104:972-5.
4. Available from: <http://www.cxignited.com>. [Last accessed on 2018 Feb 09].
5. Available from: <http://www.magellan-technology.com>. [Last accessed on 2018 Feb 09].
6. Bostwick DG. Radiofrequency identification specimen tracking in anatomical pathology: Pilot study of 1067 consecutive prostate biopsies. *Ann Diagn Pathol* 2013;17:391-402.
7. Lou JJ, Andrechak G, Riben M, Yong WH. A review of radio frequency identification technology for the anatomic pathology or biorepository laboratory: Much promise, some progress, and more work needed. *J Pathol Inform* 2011;2:34.
8. Leung AA, Lou JJ, Mareninov S, Silver SS, Routbort MJ, Riben M, *et al*. Tolerance testing of passive radio frequency identification tags for solvent, temperature, and pressure conditions encountered in an anatomic pathology or biorepository setting. *J Pathol Inform* 2010;1:21.
9. Layfield LJ, Anderson GM. Specimen labeling errors in surgical pathology: An 18-month experience. *Am J Clin Pathol* 2010;134:466-70.
10. Nash C. Radio Frequency Identification Technology and the Future Applications for Pathologists' Assistants. Available from: [http://www.pathassist.org/resource/resmgr/2014_Handouts/NashCory\(secure\).pdf](http://www.pathassist.org/resource/resmgr/2014_Handouts/NashCory(secure).pdf). [Last accessed on 2018 Feb 08].
11. US Patent 7,098,394. Method and apparatus for powering circuitry with

- on-chip solar cells within a common substrate. J. Armer and T.R. Senko, inventors. Date of patent: 29 August 2006.
12. Mandecki W, Kopacka WM, Qian Z, Ertwine V, Gedzberg K, Gruda M, *et al.* Tagging of test tubes with electronic p-chips for use in biorepositories. *Biopreserv Biobank* 2017;15:293-304.
 13. Gruda MC, Pinto A, Craelius A, Davidowitz H, Kopacka WM, Li J, *et al.* A system for implanting laboratory mice with light-activated microtransponders. *J Am Assoc Lab Anim Sci* 2010;49:826-31.
 14. Jolley-Rogers G, Yeates DK, Croft J, Cawsey EM, Suter P, Webb J, *et al.* Ultra-small RFID p-Chips on the heads of entomological pins provide an automatic and durable means to track and label insect specimens. *Zootaxa* 2012;3359:31-42.
 15. Robinson EJ, Thomas O, Richardson TO, Sendova-Franks AB, Feinerman O, Franks NR. Radio tagging reveals the roles of corpulence, experience and social information in ant decision making. *Behav Ecol Sociobiol* 2009;63:627-36.
 16. Robinson EJ, Mandecki W. In: Sun EC, editor. *Ant Colonies: Behavior in Insects*. Nova Science Publishers, Inc.; 2011.
 17. Tenczar P, Lutz CC, Rao VD, Goldenfeld N, Robinson GE. Automated monitoring reveals extreme interindividual variation and plasticity in honeybee foraging activity levels. *Anim Behav* 2014;95:41-8.
 18. Mandecki W, Rodriguez EF, Drawbridge J. Tagging of individual embryos with electronic p-chips. *Biomed Microdevices* 2016;18:100.
 19. Mandecki W, Ardelt B, Coradetti T, Davidowitz H, AFlint JA, Huang Z, *et al.* Microtransponders, the miniature RFID electronic chips, as platforms for cell growth in cytotoxicity assays. *Cytometry A* 2006;69:1097-105.
 20. Lin X, Flint JA, Azaro M, Coradetti T, Kopacka WM, Streck DL, *et al.* Microtransponder-based multiplex assay for genotyping cystic fibrosis. *Clin Chem* 2007;53:1372-6.
 21. Li J, Wang Z, Gryczynski I, Mandecki W. Silver nanoparticle-enhanced fluorescence in microtransponder-based immuno- and DNA hybridization assays. *Anal Bioanal Chem* 2010;398:1993-2001.
 22. Rich R, Li J, Fudala R, Gryczynski Z, Gryczynski I, Mandecki W, *et al.* Properties of coatings on RFID p-chips that support plasmonic fluorescence enhancement in bioassays. *Anal Bioanal Chem* 2012;404:2223-31.
 23. Laffin KE, Morris CJ, Bassik N, Jamal J, Gracias DH. Tetherless microgrippers with transponder tags. *J Microelectromech Syst* 2011;20:505-11.
 24. Luna LG. *Histopathologic Methods and Color Atlas of Special Stains and Tissue Artifacts*. Ch. 1. American Histolabs Inc., Publications Division; 1992.
 25. Johnston D, Olson K, Sawkin J, Putten KV. *Optimized Pathology Sample Storage System*; 2007. Available from: http://www.deepblue.lib.umich.edu/bitstream/2027.42/57951/1/me450f07project20_report.pdf. [Last accessed on 2018 Feb 09].
 26. Code of Federal Regulations 493.1105 – Standard: Retention Requirements; 2009. Available from: <http://www.frwebgate6.access.gpo.gov/cgi-bin/TEXTgate.cgi?WAISdocID=869289242035+94+1+0&WAISaction=retrieve>. [Last accessed on 2018 Feb 09].
 27. Potts S. *Benefits, Pitfalls and Technology: 21 CFR Part 11 Compliance in Digital Pathology Preclinical and Clinical Trials*; 2007.
 28. Hanna MG, Pantanowitz L. Bar coding and tracking in pathology. *Clin Lab Med* 2016;36:13-30.