

ORIGINAL ARTICLE

Evaluation of sex differences in the pharmacokinetics of oral sumatriptan in healthy Korean subjects using population pharmacokinetic modeling

Boram Ohk | Sookjin Seong | Joomi Lee | Miri Gwon | Wooyoul Kang |
Haewon Lee | Youngran Yoon | Heedoo Yoo 

School of Medicine, Kyungpook National University and Department of Clinical Pharmacology, Kyungpook National University Hospital, Daegu, Republic of Korea

Correspondence

Hee-Doo Yoo, School of Medicine, Kyungpook National University and Department of Clinical Pharmacology, Kyungpook National University Hospital, Daegu, Republic of Korea.
Email: yooheedoo@gmail.com

Young-Ran Yoon, School of Medicine, Kyungpook National University and Department of Clinical Pharmacology, Kyungpook National University Hospital, Daegu, Republic of Korea.
Email: yry@knu.ac.kr

Funding information

Korean Health Technology R&D Project, Ministry of Health & Welfare, Republic of Korea, Grant/Award Number: HI14C2750

Abstract

Sumatriptan was introduced in 1983, as the first of the triptans, selective 5-hydroxytryptamine (5-HT_{1B/1D}) receptor agonists, to treat moderate to severe migraine. Migraine predominates in females. Although there have been reports of sex differences in migraine-associated features and pharmacokinetics (PKs) of some triptans, sex differences in the PKs of oral sumatriptan have never been evaluated in Korean. We conducted this study of oral sumatriptan to assess the sex differences in Korean population. Thirty-eight healthy Korean subjects who participated in two separate clinical studies receiving a single oral dose of 50 mg sumatriptan with the same protocols were included in this analysis. A total of 532 sumatriptan concentration observations were used for a population PK modeling. Validation of final population PK model of sumatriptan was performed using bootstrap and visual predictive check. The PK profile of oral sumatriptan was adequately described by a one-compartmental model with combined transit compartment model and a first-order absorption. The covariate analysis showed that the clearance of oral sumatriptan was significantly higher in males than in females (male: 444 L/h, female: 281 L/h). Our results showed that there were sex differences in the clearance of oral sumatriptan. These results encourage further studies to establish the sumatriptan pharmacokinetic–pharmacodynamic model considering sex-related PK differences, which may help to determine optimal dosing regimens for effective treatment of migraine in males and females.

Clinical trial registration: CRIS Registration No. KCT0001784.

KEYWORDS

migraine, NONMEM, population pharmacokinetics, sex differences, sumatriptan

Bo-Ram Ohk and Sook-Jin Seong contributed equally to this work.

This is an open access article under the terms of the Creative Commons Attribution-NonCommercial-NoDerivs License, which permits use and distribution in any medium, provided the original work is properly cited, the use is non-commercial and no modifications or adaptations are made.

© 2021 The Authors. Biopharmaceutics & Drug Disposition published by John Wiley & Sons Ltd.

1 | INTRODUCTION

Migraine is a common neurological disorder. It is a major cause of disability in the 15–49 age group (Steiner et al., 2018). The prevalence of migraine is reported to be 12% on average, with a range from 2.6% to 21.7% between countries (Burch et al., 2015; Lipton et al., 2001; Merikangas, 2013). The prevalence is especially higher in females when compared to males at all post-pubertal ages (Scher et al., 1999). Based on this fact, several studies have been performed, which investigate the sex differences in many aspects of migraine such as symptoms (frequency, severity, and duration), migraine-associated features, and relapse of headache after treatment (Buse et al., 2013; MacGregor et al., 2011).

Sumatriptan, a selective 5-HT_{1B/1D} receptor agonist, was the first triptan approved by the US Food and Drug Administration (FDA), and other triptans (zolmitriptan, naratriptan, rizatriptan, eletriptan, almotriptan, and frovatriptan) have been developed. Sumatriptan achieves peak plasma concentration in about 2 h following oral administration, with an elimination half-life ($t_{1/2}$) of approximately 2.5 h (Cho et al., 2017; Imitrex (sumatriptan succinate) Tablets [Prescribing Information], 2012). Plasma protein binding is between 14% and 21%, with 2.4 L/kg of the apparent volume of distribution (Imitrex (sumatriptan succinate) Tablets [Prescribing Information], 2012). Following an oral dose of ¹⁴C-radiolabeled sumatriptan, it is largely excreted in the urine (60%) in the form of indole acetic acid (IAA), the major inactive metabolite, and the IAA glucuronide (Imitrex (sumatriptan succinate) Tablets [Prescribing Information], 2012). About 40% is excreted into the feces. According to several *in vitro* studies with human liver microsomes, sumatriptan is metabolized by monoamine oxidase (Fuseau et al., 2002; Imitrex (sumatriptan succinate) Tablets [Prescribing Information], 2012).

Sumatriptan belongs to the triptans recommended as first-line therapies for migraineurs with moderate-to-severe pain (Fullerton & Gengo, 1992; Gilmore & Michael, 2011; Smitherman et al., 2013). Some patients prefer the oral form of sumatriptan because it is easy to use and effective at relieving migraine pain (Dahlöf, 2001; Dahlöf et al., 2004). However, approximately 30% of patients in clinical practice experienced no headache relief after the administration of oral sumatriptan (Dodick, 2005). This variability in response to oral sumatriptan could be due to variations in PK processes, especially metabolism influencing sumatriptan concentrations at the action site (Wilkinson, 2005). In the treatment of migraine with triptans, headache relief seems to be correlated to PKs in the early phase (0–2 h), which include the initial rate of absorption and the maximum plasma concentration (Lacey et al., 1995; Tfelt-Hansen, 2007). Several studies have investigated factors that influence the PKs of triptans and observed sex differences in the PK parameters of triptans (Franconi et al., 2014; Munjal et al., 2016; Smet, 1999). However, sex differences in the PK of oral sumatriptan have only been assessed in the drug development process. Also, an evaluation has never been performed in an Asian population.

The purpose of this study was to assess sex differences in the PKs of oral sumatriptan in healthy Korean subjects. We conducted a

population PK analysis using a non-linear mixed-effect model, which can provide PK parameter estimates considering both inter- and intra-individual variabilities and identify factors that affect the PK parameters of a drug (Mould & Upton, 2012). Then we evaluated sex differences in PK parameters through the developed PK model.

2 | METHODS

2.1 | Subjects

A total of 38 healthy Korean subjects participated in this study. This clinical study was included in the previously published study (Lee et al., 2015), and the other clinical study (CRIS Registration No. KCT0001784, IRB No. KNUH 2015-07-019) conducted additionally with the same protocol design to evaluate the sex differences. These studies were approved by the Institutional Review Board of the Kyungpook National University Hospital (KNUH), Daegu, Republic of Korea. These studies were conducted at the Clinical Trial Center of KNUH, in accordance with the ethical standards of the Helsinki Declaration and Guidelines for Good Clinical Practice. After the study design and potential adverse effects of study drug were explained, written informed consent was obtained from all subjects participating in the study. Healthy adult volunteers over the age of 19 were recruited in the study. During screening, the health status of each volunteer was evaluated based on medical history, clinical laboratory tests, electrocardiography, and physical examination. Volunteers with clinically significant medical histories were excluded.

2.2 | Blood sampling and quantification of sumatriptan in plasma

Subjects received a single 50 mg oral dose of sumatriptan (Sumatran tablet 50 mg, Myung-In Pharm. Co. Ltd.). Blood samples (8 mL each) for PK analysis were obtained at pre-dose and at 0.25, 0.5, 0.75, 1, 1.5, 2, 2.5, 3, 4, 6, 8, 10, and 12 h after single dose of 50 mg sumatriptan with 150 mL of water under fasting condition. Collected blood samples were immediately transferred into heparinized tubes and stored at –80°C before analysis. Sumatriptan concentrations in plasma were analyzed using ultrahigh-performance liquid chromatography-tandem mass spectrometry. The linear calibration curves ranged between 0.5 and 50 ng/mL. Details of the analytical methods were described previously (Seo et al., 2013).

2.3 | Non-compartmental analysis (NCA)

The PK parameters of sumatriptan were determined using non-compartmental method with Phoenix WinNonlin version 7.1 (Certara). The following PK parameters were calculated; maximum plasma drug concentration (C_{max}), time to reach C_{max} (t_{max}), areas under the concentration-time curve (AUC_{0-2h} , AUC_{0-12h} , and

$AUC_{0-\infty}$), elimination half-life ($t_{1/2}$), and apparent total clearance (CL/F). The $AUC_{0-\infty}$ was calculated as $AUC_{0-t} + C_t \lambda_z^{-1}$, where C_t is the last measurable concentration and λ_z is the terminal rate constant. The statistical comparison of sumatriptan PK parameters between males and females was performed using an independent two-sample t-test or Mann-Whitney U test. When the p value was less than 0.05, it was concluded that there was a statistically significant difference in the PK parameters between males and females. The analysis was done using SPSS program (Version 18.0; SPSS Inc.).

2.4 | Population pharmacokinetic modeling

The population PK model of sumatriptan was developed using the NONMEM software (version 7.3; Icon Development Solution) (Bauer, 2013). The estimates of model parameters were obtained by first-order conditional estimation with interaction (FOCE-I) method. The plasma concentration versus time plot of sumatriptan usually showed multiple peaks (Moore et al., 1997; Sternieri et al., 2005). So, we developed a structural model using the basic model previously published (Lee et al., 2015). The structural model included a one- and two-compartment model combined with first-order elimination and nonlinear elimination (Michaelis-Menten equation), which considered the potential for saturable elimination. Various absorption models were evaluated to find the one that best described the absorption of sumatriptan, which showed multiple peaks in many subjects. These included first-order absorption followed by zero-order absorption, zero-order absorption followed by first-order absorption, and a combined transit compartment model with first-order absorption.

Figure 1 shows the scheme for a one-compartmental model with combined transit compartment model and a first-order absorption (Lee et al., 2015; Savic et al., 2007). Here, mean transit time (MTT) is the average time it takes for a drug to travel from the first transit compartment to the absorption compartment. k_{tr} is the rate constant of the drug shifting from one transit compartment to the next transit

compartment. The value of k_{tr} can be obtained from the following equation, where n is the number of transit compartments:

$$k_{tr} = \frac{n+1}{MTT}$$

The rate of change regarding drug amount in the nth transit compartment is expressed by:

$$\frac{da_n}{dt} = k_{tr} \cdot a_{(n-1)} - k_{tr} \cdot a_n$$

Here, a_n represents the amount of drug in the nth transit compartment at time t. We can estimate the number of transit compartments by solving the following equation:

$$a_n(t) = f \cdot \text{Dose} \cdot \frac{(k_{tr} \cdot t)^n}{n!} \cdot e^{-k_{tr} \cdot t}$$

where f is the fraction of absorbed dose through the transit compartment model. Between-subject variability (BSV) in each model parameter was assessed using an exponential error model and integrated into the model when the difference in objective function value (OFV) between two hierarchical models was greater than 3.84 ($p < 0.05$, $df = 1$). The unexplained residual variability was described using a combined proportional and additive error model. We selected the structural model in accordance with the criteria of goodness-of-fit which includes OFV, concurrence between observed concentrations and population concentrations predicted by the model, and examination of residuals.

2.5 | Covariate analysis

The screening of potential covariates was conducted using visual and numerical methods. A scatter plot of potential covariate versus PK parameter was used for continuous variables which include height,

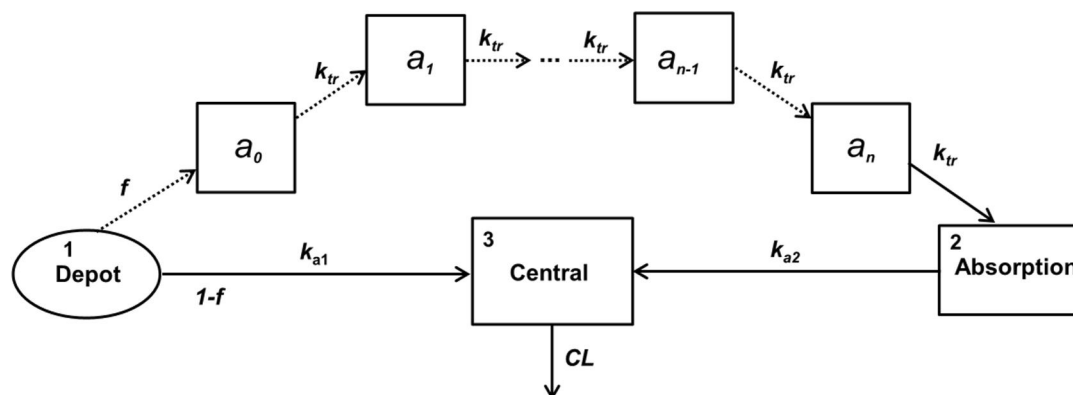

FIGURE 1 Scheme of the structural pharmacokinetic model of sumatriptan. a_n , the drug amount in the nth compartment; CL, clearance; f, fraction of the dose absorbed by the transit compartment model; k_{a1} , absorption rate constant from the depot; k_{a2} , absorption rate constant from the final transit compartment to the central compartment; k_{tr} , identical transfer rate constant of the transit compartment model; n, number of transit compartments placed before the central compartment

weight, body mass index (BMI), age, and creatinine clearance (CrCL, calculated with the Cockcroft–Gault equation). A box plot was used for categorical variable, sex. The sex variable was coded as 0 = male, 1 = female. In addition, generalized additive modeling (GAM) was performed by Xpose4 library in R (version 3.7.0; R Foundation for Statistical Computing). After screening, forward inclusion and backward elimination processes were performed to select covariates. The variable was selected as a covariate if the OFV was decreased by more than 3.84 ($p < 0.05$) and BSV was reduced in the forward selection. In the backward elimination process, the variable had to increase the OFV by at least 6.64 ($p < 0.01$). Otherwise, the variable was eliminated from the model.

2.6 | Model evaluation

For evaluation of the final model, bootstrapping was performed with the structure of the final model and 1000 datasets were re-sampled

TABLE 1 Demographic characteristics of subjects enrolled in this study (n = 38)

Variable	Mean \pm SD
Age (years)	24.8 \pm 2.7
Height (cm)	171.1 \pm 7.8
Weight (kg)	64.0 \pm 9.8
BMI (kg/m ²)	21.8 \pm 2.2
Creatinine clearance (ml/min)	119.2 \pm 17.9
Sex ^a	
Males	29 (76.3)
Females	9 (23.7)

Abbreviation: BMI, body mass index.

^aValues are n (%).

TABLE 2 Pharmacokinetic parameters from noncompartmental analysis

Parameters, unit	Total (n = 38)	Males (n = 29)	Females (n = 9)	Male/female ratio	p value ^d
AUC ₀₋₂ , ng•h/mL ^a	38.4 \pm 1.4	34.7 \pm 1.4	52.9 \pm 1.2	0.66	0.002
AUC ₀₋₁₂ , ng•h/mL ^a	125.0 \pm 1.3	111.3 \pm 1.2	182.0 \pm 1.3	0.61	<0.001
AUC _{inf} , ng•h/mL ^a	131.2 \pm 1.3	117.1 \pm 1.2	188.9 \pm 1.3	0.62	0.001
C _{max} , ng/mL ^a	31.6 \pm 1.4	29.0 \pm 1.3	41.4 \pm 1.2	0.70	0.001
T _{max} , h ^b	1.5 (0.5–4.0)	1.5 (0.5–3.0)	1.5 (1.0–4.0)	1.00	0.054
t _{1/2} , h ^c	2.8 \pm 1.0	2.9 \pm 1.0	2.6 \pm 1.3	1.12	0.223
CL/F, L/h ^c	390.7 \pm 105.0	427.8 \pm 84.0	271.2 \pm 72.7	1.58	<0.001
CL/F, L/h•kg ^c	6.1 \pm 1.5	6.4 \pm 1.5	5.1 \pm 1.2	1.25	0.010

^aGeometric mean \pm SD.

^bMedian (range).

^cMean \pm SD.

^dCompared between males and females by independent t-test and Mann–Whitney U test. $p < 0.05$ was considered statistically significant.

from the original dataset. The 95% confidence intervals (CIs) for PK parameters from the bootstrap datasets were compared with the estimate of PK parameters in the final model. Additionally, the final PK model was evaluated using a visual predictive check (VPC). A total of 1000 datasets were obtained by simulation with the model, and the 90% CI from the simulated concentration datasets was compared with the sumatriptan concentrations observed from subjects.

3 | RESULTS

3.1 | Subject characteristics

The summary of characteristics in 38 healthy subjects is given in Table 1. Study subjects consisted of 29 (76.3%) males and 9 (23.7%) females. The mean \pm SD (range) for the age was 24.8 \pm 2.7 years (21–31 years); the height was 171.1 \pm 7.8 cm (154.4–184.8 cm); the weight was 64.0 \pm 9.8 kg (50–84 kg); the BMI was 21.8 \pm 2.2 kg/m² (18.21–26.51 kg/m²); and the CrCL was 119.2 \pm 17.9 ml/min (72.2–156.31 ml/min).

3.2 | Non-compartmental analysis (NCA)

The concentration-time profiles showed there are multiple peaks in the absorption phase. The PK parameters of sumatriptan calculated by NCA are summarized in Table 2. The C_{max} of sumatriptan was higher in females than in males (1.39-fold, $p = 0.001$). The AUC₀₋₂, AUC₀₋₁₂, and AUC_{0-∞} had a higher mean value in females than in males (1.50, 1.62, and 1.61-fold, respectively, $p < 0.01$). The CL/F, inversely related to AUC_{0-∞}, was significantly higher in males than in females (1.58-fold, $p < 0.001$), and the CL/F adjusted by body weight was also higher in males than in females (1.25-fold, $p = 0.01$). On the other hand, there was no statistically significant difference between males and females in T_{max} and t_{1/2}.

3.3 | Population pharmacokinetic modeling

A total of 532 sumatriptan concentration observations from 38 healthy volunteers were used for the population PK modeling (Figure 2). The PK of sumatriptan was adequately described by one-compartmental model with combined transit compartment model and a first-order absorption (Lee et al., 2015). The following parameters of the structural PK model were estimated: (1) apparent clearance (CL/F), (2) apparent volume of distribution of the central compartment (V/F), (3) absorption rate constant of a first-order process (k_{a1}), (4) lag time for k_{a1} (ALAG1), (5) absorption rate constant from the absorption compartment to the central compartment (k_{a2}), (6) mean transit time (MTT), (7) number of transit compartments (NN), and (8) fraction of drug absorbed into the transit

compartment model (f). The BSV in CL/F, V/F, k_{a2} , and MTT was incorporated into the PK model. The basic goodness-of-fit plots of the final PK model are given in Figure 3. For the population and individuals, the predicted concentrations correlated with the observed concentrations. The conditional weighted residual plots did not show any trends, and the values of residuals were within ± 4 .

3.4 | Covariate analysis

The results of the covariate analysis are summarized in Table 3. Age, height, BMI, and CrCL did not significantly impact CL/F, V/F, k_{a2} , and MTT. Weight seemed to be a statistically significant covariate for CL/F ($\Delta\text{OFV} = -10.541$, $p < 0.005$). However, sex was a more statistically

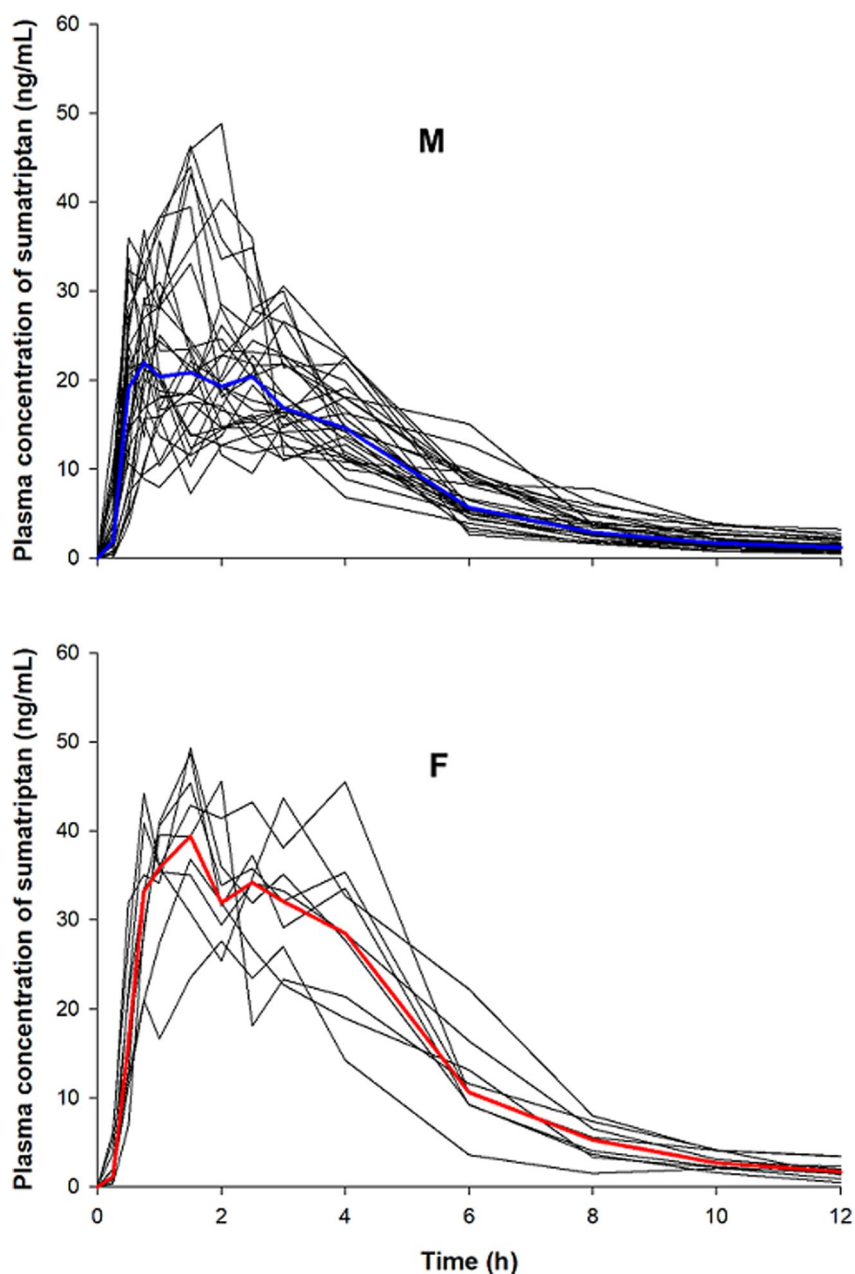

FIGURE 2 Individual plasma concentration-time profiles of sumatriptan in 38 healthy subjects. The bold line is the median concentration for males (M) and females (F)

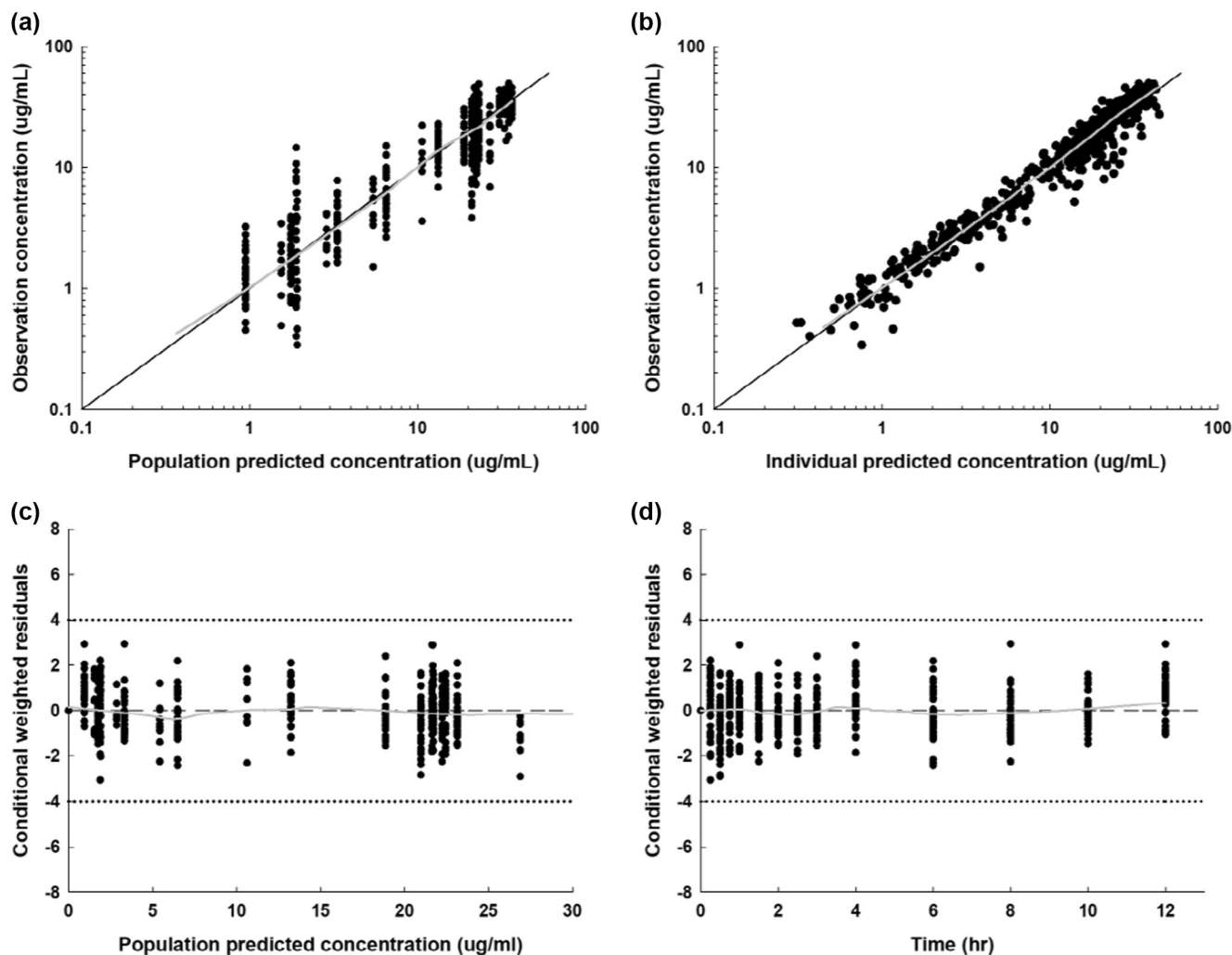

FIGURE 3 Goodness of fit plots for the final pharmacokinetic model of sumatriptan. Gray lines represent locally estimated scatter plot smoothing

significant covariate for CL/F ($\Delta\text{OFV} = -26.174$, $p < 0.001$) compared with the structural model. Furthermore, sex adjusted by body weight only impacted the clearance ($\Delta\text{OFV} = -15.634$, $p < 0.001$). So, the model with sex as covariate for CL/F was selected for the final model. Estimates of the parameters and variabilities are shown in Table 4. The subpopulation estimates of CL/F in males and females were 444 and 281 L/h, respectively. The distribution of sumatriptan CL/F estimated from the PK model is shown by sex in Figure 4.

3.5 | Model evaluation

The parameter estimates of the final PK model and their bootstrap results are shown in Table 4. The population estimates of the final PK model were within the 95% CI obtained by the bootstrap. This indicated that the final PK model was accurate and robust. The VPCs, stratified by sex showed that the final model adequately predicted the trend and variability of the observed sumatriptan concentrations (Figure 5).

4 | DISCUSSION

This study assessed sex differences in the PK of oral sumatriptan in Korean using a population PK approach with NONMEM. The PK profile of oral sumatriptan with multiple peaks was well described by the one-compartmental model with combined transit compartment model and a first-order absorption (Lee et al., 2015). The population estimate of CL/F generated by the structural model was 374 L/h, which was similar to the estimate (390.7 L/h) calculated by NCA in this study.

Covariate analysis from this study showed that clearance of oral sumatriptan was 1.58-fold higher in males than in females. This is consistent with the results comparing sexes in CL/F from NCA in this study. However, these differences in CL/F may be due to body weight differences between sexes, which are generally considered a sex difference. Thus, we evaluated the sex differences in clearance adjusted by body weight. This was done by evaluating the sex variable as an additional covariate to clearance in the model that already included weight as a covariate to clearance. As a result, the sex differences in the clearance adjusted by body weight were statistically

TABLE 3 Summary of covariate analysis process

No.	Potential covariate	Model	Compared against	Δ OFV ^a	Significance
1	Structural model	$CL = \theta_1 \cdot e^{\eta_1}, V = \theta_2 \cdot e^{\eta_2}$	-	-	-
2	Age to CL	$CL = (\theta_1 \cdot (AGE/\overline{AGE})^{\theta_{AGE}}) \cdot e^{\eta_1}$	1	-0.619	NS
3	Weight to CL	$CL = (\theta_1 \cdot (WT/\overline{WT})^{\theta_{WT}}) \cdot e^{\eta_1}$	1	-10.541*	<0.005
4	Sex to CL	$CL = ((1 - SEX) \cdot \theta_{1,male} + SEX \cdot \theta_{1,female}) \cdot e^{\eta_1}$	1	-26.174*	<0.001
5	Sex and weight to CL	$CL = ((1 - SEX) \cdot \theta_{1,male} + SEX \cdot \theta_{1,female}) \cdot (WT/\overline{WT})^{\theta_{WT}} \cdot e^{\eta_1}$	3	-15.634*	<0.001
			4	-0.001	NS
6	Sex and height to CL	$CL = ((1 - SEX) \cdot \theta_{1,male} + SEX \cdot \theta_{1,female}) \cdot (HT/\overline{HT})^{\theta_{HT}} \cdot e^{\eta_1}$	4	-0.045	NS
7	Sex and BMI to CL	$CL = ((1 - SEX) \cdot \theta_{1,male} + SEX \cdot \theta_{1,female}) \cdot (BMI/\overline{BMI})^{\theta_{BMI}} \cdot e^{\eta_1}$	4	-0.011	NS
8	Sex and CrCL to CL	$CL = ((1 - SEX) \cdot \theta_{1,male} + SEX \cdot \theta_{1,female}) \cdot (CrCL/\overline{CrCL})^{\theta_{CrCL}} \cdot e^{\eta_1}$	4	-0.003	NS
9	Age to V	$V = (\theta_2 \cdot (AGE/\overline{AGE})^{\theta_{AGE}}) \cdot e^{\eta_2}$	1	-0.013	NS
10	Weight to V	$V = (\theta_2 \cdot (WT/\overline{WT})^{\theta_{WT}}) \cdot e^{\eta_2}$	1	-0.061	NS
11	Sex to V	$V = ((1 - SEX) \cdot \theta_{2,male} + SEX \cdot \theta_{2,female}) \cdot e^{\eta_2}$	1	-0.354	NS
12	Height to V	$V = (\theta_2 \cdot (HT/\overline{HT})^{\theta_{HT}}) \cdot e^{\eta_2}$	1	-0.002	NS
13	BMI to V	$V = (\theta_2 \cdot (BMI/\overline{BMI})^{\theta_{BMI}}) \cdot e^{\eta_2}$	1	-0.047	NS
14	CrCL to V	$V = (\theta_2 \cdot (CrCL/\overline{CrCL})^{\theta_{CrCL}}) \cdot e^{\eta_2}$	1	-0.044	NS

Abbreviation: NS, no statistically significant differences.

^a Δ OFV was calculated by subtracting OFV of base model from OFV of each covariate model.

*Statistically significant ($p < 0.001$).

TABLE 4 Parameter estimates from the final population pharmacokinetic model

Parameter (unit)	Definition	Estimate (%RSE)	BSV (CV%) (%RSE)	95% CI ^a	Shrinkage of BSV (%)
CL/F _M (L/h)	Apparent oral clearance for male	444 (4)	17.5 (25)	388–452	7
CL/F _F (L/h)	Apparent oral clearance for female	281 (7)		232–311	
V ₃ /F (L)	Apparent volume of distribution	68.7 (32)	99.9 (30)	17.8–137.2	2
k _{a1} (h ⁻¹)	Absorption rate constant of first-order absorption	0.568 (12)	-	0.28–0.80	-
k _{a2} (h ⁻¹)	Absorption rate constant from the final transit compartment to the central compartment	0.295 (5)	23.04 (31)	0.27–0.53	17
MTT (h)	Mean transit time	1.52 (11)	42.43 (32)	1.16–2.15	12
NN	Number of transit compartments	6.7 (48)	-	1.7–19.8	-
ALAG ₁ (h)	Lag time for k _{a1}	0.239 (1)	-	0.23–0.25	-
f	Fraction of the dose absorbed by transit compartment model	0.558 (7)	-	0.41–0.73	-
Proportional error		0.249 (6)	-	0.17–0.59	-
Additive error		0.276 (21)	-	0.21–0.27	-

Abbreviations: -, not estimated; BSV, between-subject variability; CV, coefficient of variation; RSE, relative standard error.

^a95% CI is the 95% percentile confidence interval from bootstrap (1000 samples).

significant. This indicates that weight differences between males and females cannot fully explain the sex differences in CL/F. Moreover, due to a weak correlation between weight and CL/F, the OFV

decreased more when sex was considered as a covariate to CL/F than when sex and weight were considered together. Thus, the final PK model included only sex variable as a covariate to CL/F.

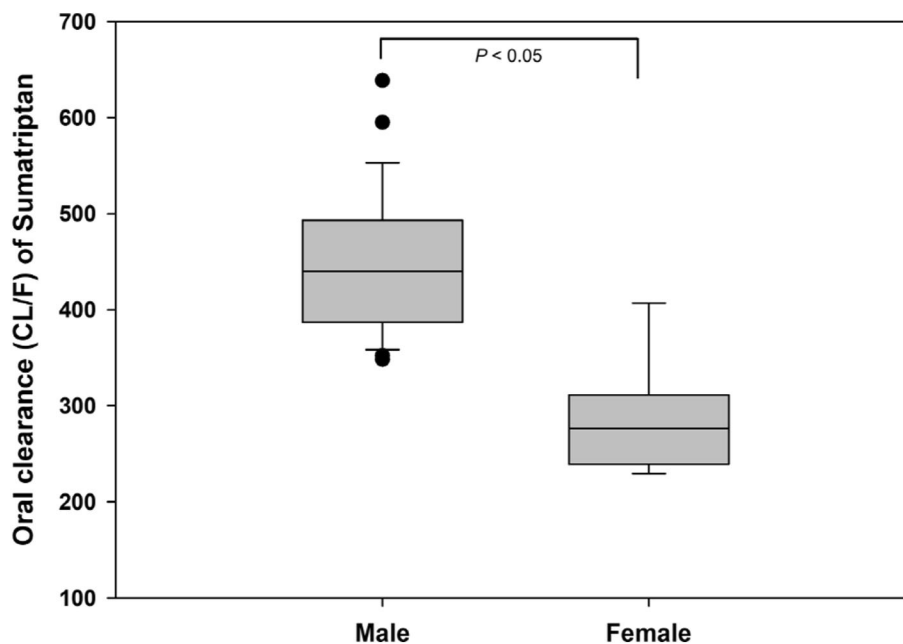

FIGURE 4 Box-plot of clearance (CL/F) of sumatriptan in males and females from the population pharmacokinetic model. The lower and upper edge of the boxplot represents the first quartile and the third quartile. The whiskers are 5th and 95th percentile. Solid circles indicate outliers

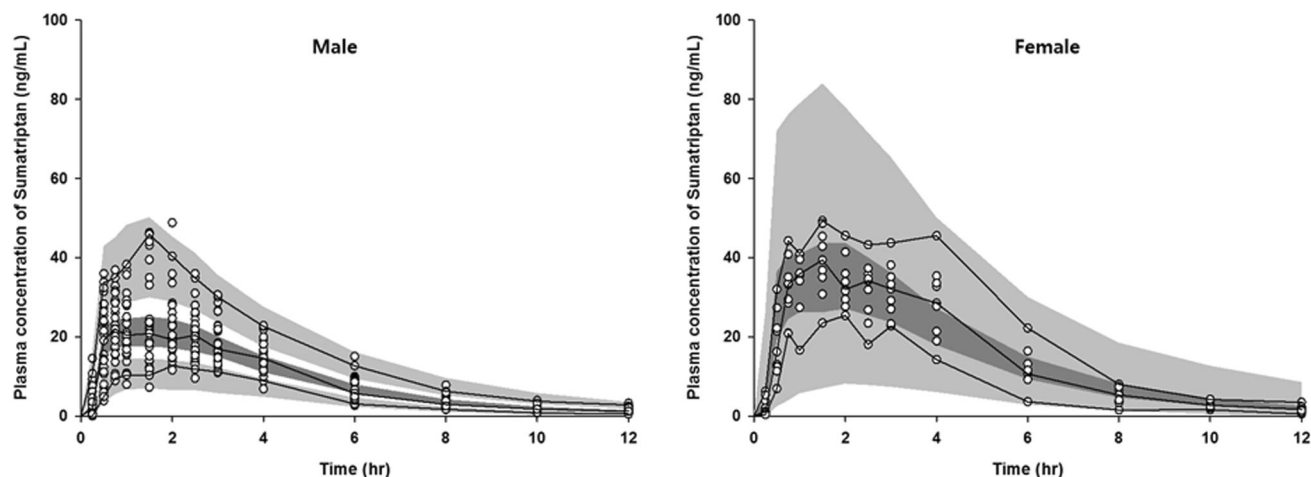

FIGURE 5 Visual predictive checks for the final PK model of oral sumatriptan in males (left panel) and females (right panel). Open circles represent the observed sumatriptan plasma concentrations; black solid lines show the observed medians of concentration of the 5th, median, and 95th percentile; dark gray regions show 95% CI of the predicted medians; and light gray regions show 95% CI of the 90% prediction intervals obtained by the simulation

Several studies on triptans have reported sex-related differences in PK parameters. In a pooled analysis of healthy subjects using subcutaneous sumatriptan, the sex had an additional effect on the regression model of PK parameters including weight or BMI (Munjal et al., 2016). AUC and C_{max} that have an inverse relationship with CL, were higher in females than in males. However, investigators concluded that this sex effect arose from the differences in weight between males and females. In a PK study conducted in healthy volunteers, the apparent plasma clearance of oral rizatriptan metabolized by MAO-A was ~25% higher in males than in females (Smet, 1999).

Lidia et al. reported significantly higher C_{max} and half-life values in females compared to those in male subjects after conducting a study to evaluate the efficacy and PK of frovatriptan in patients with moderate to severe migraine (Savi et al., 2014). In addition, the C_{max} was positively correlated with the proportion of patients that were either pain-free or experienced pain relief over the entire study period. In contrast, males and females were of comparable $t_{1/2}$ in NCA in our sumatriptan PK study. $t_{1/2}$ is calculated with terminal slope of PK curve in NCA. So, it showed that there is a small difference in terminal elimination phase between males and females.

Most of the variability in drug response has its origins in PK (Marchant, 1981). However, few studies have investigated PK differences between the responders and non-responders for sumatriptan. Ferrari et al. reported that patients who responded positively to sumatriptan absorbed the drug more rapidly and had a higher drug exposure in the first 2 h after dosing than patients who did not respond positively to the drug (Ferrari et al., 2008). Visser et al. reported that CL was significantly higher in a non-responder group compared to a responder group after administration of sumatriptan (Visser et al., 1996). Most information evaluating for sex differences in renal excretion of drugs is from the studies on glomerular filtration. Although the glomerular filtration rate (GFR) is directly proportional to lean body weight, the GFR is about 10% lower in women than in men after normalization for weight (Gross et al., 1992; Parekh, 2013). Regarding renal tubular secretion or tubular reabsorption, less is known of the impact of sex in humans. The organic cation transport (OCT) 2 is responsible for the sex differences in renal basolateral membrane OCT activity reported in rat (Urakami et al., 1999). Urakami et al. suggested up-regulation of renal rat OCT2 expression by testosterone and down-regulation by estradiol (Urakami et al., 2000). Approximately 50% higher renal clearance has been reported in men for amantadine, one of the actively secreted drug by OCT2, compared to that in women (Parekh, 2013). There is little evidence for sex-dependent variability in both Phase I and Phase II metabolic pathways (Parekh, 2013). Following oral administration, sumatriptan is excreted in its metabolite form via urine (60%) or into feces (40%). The hepatic uptake of sumatriptan is mediated by the hepatic OCT1, with the impact of OCT1 polymorphisms on the sumatriptan pharmacokinetics (Matthaei et al., 2016). Unlike OCT2, the expression of OCT1 and OCT3 in rat is not induced by testosterone (Asaka et al., 2006).

In this study, there are some limitations. These include sample size ($n = 38$) and subject selection (this study only used healthy subjects). Thus, it is necessary to further validate our model for migraine patients. In addition, it was impossible to assess sex differences in pharmacodynamic (PD) response. As the sex-related clinical differences were not considered in these studies, further research is needed to evaluate the impact on PD due to PK differences related to sex. Integration of PK and PD data may be helpful in evaluating sex effect on the response to oral sumatriptan and in treating patients suffering from migraine.

5 | CONCLUSIONS

This study assessed sex differences in the PKs of oral sumatriptan in Korean. The PK profile of oral sumatriptan fit well with a one-compartmental model with combined transit compartment and a first-order absorption. Covariate analysis with the model showed that there are sex differences in CL/F of oral sumatriptan (1.58-fold higher in males than in females). Further studies are warranted to understand the mechanisms of sex differences in the oral clearance of sumatriptan.

Our results could be helpful in the design and implementation of clinical trials that evaluate sumatriptan PD, which take into consideration sex-related PK differences. In addition, the population PK model developed in this study can be the basis for the PK-PD model of sumatriptan, which helps determine optimal dosing regimens to effectively treat migraine in males and females.

ACKNOWLEDGMENTS

This study was supported by a grant of the Korean Health Technology R&D Project, Ministry of Health & Welfare, Republic of Korea (HI14C2750).

CONFLICT OF INTERESTS

The authors declare that they have no conflict of interest.

DATA AVAILABILITY STATEMENT

The data that support the findings of this study are available from the corresponding author upon reasonable request.

ORCID

Heedoo Yoo  <https://orcid.org/0000-0002-4404-8976>

REFERENCES

- Asaka, J., Terada, T., Okuda, M., Katsura, T., & Inui, K. (2006). Androgen receptor is responsible for rat organic cation transporter 2 gene regulation but not for rOCT1 and rOCT3. *Pharmaceutical Research*, 23(4), 697–704. <https://doi.org/10.1007/s11095-006-9665-2>
- Bauer, R. (2013). *Introduction to NONMEM 7.3. O. NONMEM users guide*. ICON Development Solutions.
- Burch, R. C., Loder, S., Loder, E., & Smitherman, T. A. (2015). The prevalence and burden of migraine and severe headache in the United States: Updated statistics from government health surveillance studies. *Headache: The Journal of Head and Face Pain*, 55(1), 21–34.
- Buse, D. C., Loder, E. W., Gorman, J. A., Stewart, W. F., Reed, M. L., Fanning, K. M., Serrano, D., & Lipton, R. B. (2013). Sex differences in the prevalence, symptoms, and associated features of migraine, probable migraine and other severe headache: Results of the American Migraine Prevalence and Prevention (AMPP) study. *Headache: The Journal of Head and Face Pain*, 53(8), 1278–1299.
- Cho, S., Jegal, M., Ohk, B., Kim, B. K., Gwon, M. R., Kang, W. Y., Seong, S. J., Kim, H. J., Lee, H. W., & Yoon, Y. R. (2017). Determination of sumatriptan in human plasma using liquid chromatography-mass spectrometry for pharmacokinetic study in healthy Korean volunteers. *Translational and Clinical Pharmacology*, 25(2), 106–111. <https://doi.org/10.12793/tcp.2017.25.2.106>
- Dahlöf, C. (2001). *Assessing patient preference in migraine treatment*. Sage.
- Dahlöf, C., Jones, M., Davis, K., Loftus, J., & Salonen, R. (2004). A comparison of preference for and efficacy of tablet formulations of sumatriptan (50 mg and 100 mg), naratriptan (2.5 mg), rizatriptan (10 mg), and zolmitriptan (2.5 mg) in the acute treatment of migraine. *The Journal of Headache and Pain*, 5(2), 115.
- Dodick, D. W. (2005). Triptan nonresponder studies: Implications for clinical practice. *Headache: The Journal of Head and Face Pain*, 45(2), 156–162.
- Ferrari, A., Pinetti, D., Bertolini, A., Coccia, C., & Sternieri, E. (2008). Interindividual variability of oral sumatriptan pharmacokinetics and of clinical response in migraine patients. *European Journal of Clinical Pharmacology*, 64(5), 489–495.

- Franconi, F., Finocchi, C., Allais, G., Omboni, S., Tullo, V., Campesi, I., Reggiardo, G., Benedetto, C., & Bussone, G. (2014). Gender and triptan efficacy: A pooled analysis of three double-blind, randomized, crossover, multicenter, Italian studies comparing frovatriptan vs. other triptans. *Neurological Sciences*, 35(1), 99–105.
- Fullerton, T., & Gengo, F. M. (1992). Sumatriptan: A selective 5-hydroxytryptamine receptor agonist for the acute treatment of migraine. *Annals of Pharmacotherapy*, 26(6), 800–808.
- Fuseau, E., Petricoul, O., Moore, K. H., Barrow, A., & Ibbotson, T. (2002). Clinical pharmacokinetics of intranasal sumatriptan. *Clinical Pharmacokinetics*, 41(11), 801–811. <https://doi.org/10.2165/00003088-200241110-00002>
- Gilmore, B., & Michael, M. (2011). Treatment of acute migraine headache. *American Family Physician*, 83(3), 271–280.
- Gross, J. L., Friedman, R., Azevedo, M. J., Silveiro, S. P., & Pecis, M. (1992). Effect of age and sex on glomerular filtration rate measured by ⁵¹Cr-EDTA. *Brazilian Journal of Medical and Biological Research*, 25(2), 129–134.
- Imitrex (sumatriptan succinate) Tablets [Prescribing Information]. (2012). https://www.accessdata.fda.gov/drugsatfda_docs/label/2012/020132s024s026lbl.pdf
- Lacey, L., Hussey, E., & Fowler, P. (1995). Single dose pharmacokinetics of sumatriptan in healthy volunteers. *European Journal of Clinical Pharmacology*, 47(6), 543–548.
- Lee, J., Lim, M. S., Seong, S. J., Park, S. M., Gwon, M. R., Han, S., Lee, S. M., Kim, W., Yoon, Y. R., & Yoo, H. D. (2015). Population pharmacokinetic analysis of the multiple peaks phenomenon in sumatriptan. *Translational and Clinical Pharmacology*, 23(2), 66–74.
- Lipton, R. B., Stewart, W. F., Diamond, S., Diamond, M. L., & Reed, M. (2001). Prevalence and burden of migraine in the United States: Data from the American Migraine Study II. *Headache: The Journal of Head and Face Pain*, 41(7), 646–657.
- MacGregor, E. A., Rosenberg, J. D., & Kurth, T. (2011). Sex-related differences in epidemiological and clinic-based headache studies. *Headache: The Journal of Head and Face Pain*, 51(6), 843–859.
- Marchant, B. (1981). Pharmacokinetic factors influencing variability in human drug response. *Scandinavian Journal of Rheumatology*, 10(sup39), 5–14.
- Matthaei, J., Kuron, D., Faltraco, F., Knoch, T., Dos Santos Pereira, J. N., Abu Abed, M., Prukop, T., Brockmüller, J., & Tzvetkov, M. V. (2016). OCT1 mediates hepatic uptake of sumatriptan and loss-of-function OCT1 polymorphisms affect sumatriptan pharmacokinetics. *Clinical Pharmacology and Therapeutics*, 99(6), 633–641. <https://doi.org/10.1002/cpt.317>
- Merikangas, K. R. (2013). Contributions of epidemiology to our understanding of migraine. *Headache: The Journal of Head and Face Pain*, 53(2), 230–246.
- Moore, K., Hussey, E., Shaw, S., Fuseau, E., Duquesnoy, C., & Pakes, G. (1997). Safety, tolerability, and pharmacokinetics of sumatriptan in healthy subjects following ascending single intranasal doses and multiple intranasal doses. *Cephalalgia*, 17(4), 541–550.
- Mould, D. R., & Upton, R. (2012). Basic concepts in population modeling, simulation, and model-based drug development. *CPT: Pharmacometrics & Systems Pharmacology*, 1(9), 1–14.
- Munjal, S., Gautam, A., Rapoport, A. M., & Fisher, D. M. (2016). The effect of weight, body mass index, age, sex, and race on plasma concentrations of subcutaneous sumatriptan: A pooled analysis. *Clinical Pharmacology: Advances and Applications*, 8, 109–116.
- Parekh, A. (2013). *Principles of clinical pharmacology* (3rd ed.). Elsevier.
- Savi, L., Mogavero, S., & Egan, C. G. (2014). Efficacy and pharmacokinetic activity of frovatriptan compared to rizatriptan in patients with moderate-to-severe migraine. *Drug Design, Development and Therapy*, 8, 983.
- Savic, R. M., Jonker, D. M., Kerbusch, T., & Karlsson, M. O. (2007). Implementation of a transit compartment model for describing drug absorption in pharmacokinetic studies. *Journal of Pharmacokinetics and Pharmacodynamics*, 34(5), 711–726.
- Scher, A. I., Stewart, W. F., & Lipton, R. B. (1999). Migraine and headache: A meta-analytic approach. *Epidemiology of Pain*, 159, 170.
- Seo, J. J., Park, J., Bae, M. H., Lim, M. S., Seong, S. J., Lee, J., Park, S. M., Lee, H. W., & Yoon, Y. R. (2013). Rapid determination of sumatriptan in human plasma by ultra performance liquid chromatography–tandem mass spectrometry and its application to clinical pharmacokinetic study. *Journal of Chromatography B*, 919, 38–42.
- Smet, D. (1999). Pharmacokinetics and tolerability of oral rizatriptan in healthy male and female volunteers. *British Journal of Clinical Pharmacology*, 47(4), 373–378.
- Smitherman, T. A., Burch, R., Sheikh, H., & Loder, E. (2013). The prevalence, impact, and treatment of migraine and severe headaches in the United States: A review of statistics from national surveillance studies. *Headache: The Journal of Head and Face Pain*, 53(3), 427–436.
- Steiner, T. J., Stovner, L. J., Vos, T., Jensen, R., & Katsarava, Z. (2018). *Migraine is first cause of disability in under 50s: Will health politicians now take notice?* Springer.
- Sternieri, E., Pinetti, D., Coccia, C. P., Leone, S., Bertolini, A., & Ferrari, A. (2005). Pharmacokinetics of sumatriptan in non-respondent and in adverse drug reaction reporting migraine patients. *The Journal of Headache and Pain*, 6(4), 319–321.
- Tfelt-Hansen, P. (2007). Parenteral vs. oral sumatriptan and naratriptan: Plasma levels and efficacy in migraine. A comment. *The Journal of Headache and Pain*, 8(5), 273–276.
- Urakami, Y., Nakamura, N., Takahashi, K., Okuda, M., Saito, H., Hashimoto, Y., & Inui, K. (1999). Gender differences in expression of organic cation transporter OCT2 in rat kidney. *FEBS Letters*, 461(3), 339–342. [https://doi.org/10.1016/s0014-5793\(99\)01491-x](https://doi.org/10.1016/s0014-5793(99)01491-x)
- Urakami, Y., Okuda, M., Saito, H., & Inui, K. (2000). Hormonal regulation of organic cation transporter OCT2 expression in rat kidney. *FEBS Letters*, 473(2), 173–176. [https://doi.org/10.1016/s0014-5793\(00\)01525-8](https://doi.org/10.1016/s0014-5793(00)01525-8)
- Visser, W. H., Burggraaf, J., Muller, L. M., Schoemaker, R. C., Fowler, P. A., Cohen, A. F., & Ferrari, M. D. (1996). Pharmacokinetic and pharmacodynamic profiles of sumatriptan in migraine patients with headache recurrence or no response. *Clinical Pharmacology and Therapeutics*, 60(4), 452–460.
- Wilkinson, G. R. (2005). Drug metabolism and variability among patients in drug response. *New England Journal of Medicine*, 352(21), 2211–2221.

How to cite this article: Ohk, B., Seong, S., Lee, J., Gwon, M., Kang, W., Lee, H., Yoon, Y., & Yoo, H. (2022). Evaluation of sex differences in the pharmacokinetics of oral sumatriptan in healthy Korean subjects using population pharmacokinetic modeling. *Biopharmaceutics & Drug Disposition*, 43(1), 23–32. <https://doi.org/10.1002/bdd.2307>