

The Relationship Between Study Engagement and Critical Thinking Among Higher Vocational College Students in China: A Longitudinal Study

Shuai Lv^{1,2}, Chunmei Chen³, Wei Zheng⁴, Yujie Zhu⁵ 

¹Institute of Education, Xiamen University, Xiamen, Fujian, People's Republic of China; ²School of Modern Logistics, Qingdao Harbor Vocational and Technical College, Qingdao, People's Republic of China; ³Teachers College, Jimei University, Xiamen, Fujian, 361021, People's Republic of China; ⁴Department of Tourism, Fudan University, Shanghai, People's Republic of China; ⁵School of Marine Culture and Law, Jimei University, Xiamen, Fujian, People's Republic of China

Correspondence: Chunmei Chen, Teachers College, Jimei University, Xiamen, Fujian, People's Republic of China, Email chunmei88g@jmu.edu.cn

Purpose: Numerous cross-sectional studies have explored the correlation between study engagement and critical thinking, but the relationship between the development of these two key variables over time is unclear and the causal relationship between them remains controversial. In this study, we examined the developmental trajectories of and the interplay between study engagement and critical thinking.

Methods: We used a questionnaire method to follow 654 first-year students in Chinese higher vocational college over a period of one year and three times, of which 231 (35.321%) were male and 423 (64.679%) were female, with an average age of 18.11 years. Descriptive statistics were used to present general characteristics of the study participants, and latent growth model was used to explore the developmental trajectories of study engagement and critical thinking, and to explore the interplay between study engagement and critical thinking from a developmental perspective. Based on this, a cross-lagged model was used to verify the causal relationship between study engagement and critical thinking.

Results: During the first year of higher vocational college in China, students' levels of study engagement and critical thinking declined continuously. The initial level and development of study engagement can positively influence the initial level and development of critical thinking, respectively, while the initial level and development of critical thinking can in turn positively influence the initial level and development of study engagement, respectively. Study engagement and critical thinking can predict each other.

Conclusion: The above results help researchers and educators to develop study engagement and critical thinking in higher vocational college students from a developmental perspective. The development of either aspect of study engagement and critical thinking can contribute to the joint improvement of both.

Keywords: study engagement, critical thinking, higher vocational college students, latent growth model, cross-lagged model, longitudinal study

Introduction

Critical thinking is one of the necessary skills for the 21st century,¹ which has become a globally recognized goal for higher education.² Driven by rapid advances in science and technology and economic globalization, now more than ever before, college graduates are expected to have critical thinking skills to cope with the changing and complex work environment and higher job requirements of the 21st century.^{3,4} Critical thinking plays an important part in individual's logical thinking, representing both an individual's ability to make rational decisions and perform self-examination, and a purposeful higher-order rational thinking process.⁵ Numerous studies have found that critical thinking is not only effective in enhancing individuals' problem-solving skills,⁶ metacognition,⁷ facilitating the learning process,⁸ and preparing them for future careers.⁹ Meanwhile, critical thinking helps students to make informed decisions in their daily lives, gain success in this ever-changing world,¹⁰ and achieve higher earnings.¹¹ In view of the positive effects of critical thinking on individual development, researchers have sought to explore and identify the factors that can influence an individual's level of critical thinking. Among

the many influencing factors, there is a significantly positive correlation between an individual's study engagement in the learning process and critical thinking; the more students are engaged in the learning process, the higher level of critical thinking they are likely to have.¹²

Although there is a correlation between study engagement and critical thinking, our understanding of the relationship between these two factors remains deficient. To begin with, the developmental trajectories of study engagement and critical thinking, and the interactions between the two deserve empirical research. Although study engagement and critical thinking are stable characteristics that students possess, some studies have found that study engagement and critical thinking would change with age.^{13,14} This suggests that these two factors may interact with each other over time. Second, because of the lack of longitudinal studies on study engagement and critical thinking, we do not have a clear understanding of the causal relationship between the two. Existing cross-sectional studies on this topic suggest that findings on the predicted direction between study engagement and critical thinking are inconsistent.^{12,15–17} It remains unclear whether study engagement is an antecedent or consequence of critical thinking.

Currently, college students' study engagement as an important evaluation criterion of higher education quality¹⁸ and critical thinking as an important goal of higher education² have attracted widespread attention in higher education institutions worldwide. But unfortunately, current research on study engagement and critical thinking has focused on more university students in general higher education and less on students in higher vocational education. In China, students in higher vocational education account for more than half of all students in higher education. The same is true in the United States, where students in higher vocational education make up the majority of community college enrollment.¹⁹ In the past, vocational education focused on specific trades and was considered to be a simple form of manual labor.²⁰ People often associate vocational education with the activities of lower social classes, creating a form of discrimination against vocational education.²¹ As the labor market becomes more specialized, the process of economic globalization in the 21st century requires more skilled professionals to acquire more challenging academic and technical skills, which requires students in higher vocational education to be more engaged in learning and to think more critically. These suggest that more research focus should be placed on students in higher vocational education.

This study aims to fill these gaps through three sets of longitudinal data collected from Chinese higher vocational college students. A latent growth model was used to explore the developmental trajectories of study engagement and critical thinking, and to explore the interaction between study engagement and critical thinking from a developmental perspective. Based on this, in order to further determine the causal relationship between study engagement and critical thinking, we used a cross-lagged model. The findings of these two longitudinal studies provide a theoretical basis for the enhancement of study engagement and critical thinking in the developmental process of higher vocational college students.

The Developmental Relations Between Study Engagement and Critical Thinking Over Time

The concept of critical thinking can be traced back 2500 years to Socrates' "matrimonial art", which emphasized the importance of analysis using evidence, questioning, etc. There are many definitions of critical thinking, and one widely cited definition is Norris and Ennis' formulation that critical thinking is reasoned, reflective thinking, which aims to determine our beliefs and actions.²² Educators around the world attach great importance to the critical thinking of college graduates.²³ National policymakers and accreditation bodies also recognize the importance of developing critical thinking skills, as reflected in the increased emphasis on critical thinking development as a learning outcome and its inclusion in several educational standards and accreditation criteria around the world.²⁴ In addition, companies when hiring college graduates generally expect them to have stronger critical thinking skills. In a 2018 survey of corporate employers conducted by the Association of American Colleges and Universities, 84% of corporate executives and 78% of personnel hiring managers identified critical thinking skills as one of the most important learning outcomes for college graduates.²⁵ The positive role of education in enhancing and promoting students' critical thinking development is well recognized.⁸ Educators and psychologists view critical thinking as a competency that can be acquired through training and learning,^{26,27} so institutions of higher education are expected to help college students develop their critical thinking abilities by promoting the learning of college students.^{28,29} Thus, study engagement, an important variable in measuring the quality of learning of university students,³⁰ is

closely related to the development of critical thinking.^{12,15–17,31} Study engagement refers primarily to the time and effort students invest in activities inside and outside the classroom, which mainly consists of three main areas: behavioral engagement, cognitive engagement and affective engagement.^{32,33} Behavioral engagement means positive behaviors that are invested in academic and social activities; cognitive engagement refers to students' investment and effort in strategies, motivations, and expectations related to engaging in deeply self-directed learning; affective engagement reflects joy, enthusiasm, interest, attachment, belonging, and reactions to and relationships with others.³⁴

College students are still in the adolescent stage of their developmental process, their study engagement and critical thinking are not static, but are subject to some developmental changes.^{14,27} Previous research has shown that there are certain trajectories in study engagement and critical thinking. First of all, in the trajectories of study engagement, students at different ages in different cultures show different developmental trajectories, but most studies have found that student engagement tends to decline with age in adolescence. For example, a study in a Canadian sample of students by Archambault et al showed that the majority of 14–16-year-old students had declining trajectories of study engagement over time.³⁵ Data from a study in New Zealand found that students between the ages of 10 and 16 had different trajectories in their study engagement level, but the overall level showed a downward trajectory.¹⁴ In a study with a sample of Chinese undergraduate students, considerable grade differences in learning engagement were found, as evidenced by the fact that freshmen students were significantly more engaged in learning than sophomores and juniors.³⁶ Besides, others have found that Chinese college students' learning investment was low in sophomore year.³⁷ Therefore, we conducted a longitudinal study of Chinese senior students to provide more evidence to accurately describe the developmental trajectory of Chinese higher vocational college students' study engagement.

As for the developmental trajectories of students' critical thinking, although the existing research results are not uniform in different cultural backgrounds, in general, it has been observed that students' critical thinking is on the rise during their college years. In the United States, overall, the critical thinking tendency of college students during their school years increases step by step with grade level.^{38–40} However, one study of students at a public research university in the United States also found that students did not add substantial value to their critical thinking skills in the first two years of college, and instead showed a decrease in the value-added effect by the third year, with students showing significant value-added in critical thinking after the fourth to fifth years.⁴¹ In other countries, for example, a study that tracked German medical undergraduates for five years found that students' scores on critical thinking decreased from year one to year five, although there was no significant difference in their overall scores.⁴² In China, it has been found that, on average, undergraduate students' critical thinking skills improve during higher education.⁴³ However, by grade level, it is characterized by a high starting point of critical thinking performance among Chinese undergraduate students,⁴⁴ a low point during the sophomore year,⁴⁵ and growth starts to resume in the junior and senior years.

In summary, previous research has described the developmental trajectory of study engagement or critical thinking skills separately, and there are also studies that support the existence of a significant positive relationship between study engagement and critical thinking from a static perspective.^{12,15–17} However, the research to date has not dealt with the relationship between the two variables over time, lacking a dynamic temporal developmental perspective to investigate the relationship between study engagement and critical thinking. Therefore, it is necessary to systematically investigate the effect of the initial level of the independent variable on the initial level and developmental rate of the dependent variable using a longitudinal tracking approach, as well as the role of the developmental trajectories of the independent variable on the dependent variable. Therefore, this study used a latent variable growth model to explore the dynamic developmental patterns of study engagement and critical thinking as well as the mechanisms of influence.

The Causal Relations Between Study Engagement and Critical Thinking

Although existing research has found a correlation between study engagement and critical thinking, the causal relationship between the two is unclear. The first view suggests that study engagement positively predicts critical thinking.¹² The study engagement theory proposed by Astin has suggested that the quality and quantity of students' engagement in a variety of academic and social activities in the institutional setting during the learning process are proportional to the outcome of personal development.⁴⁶ As a higher-order cognitive ability, critical thinking skills are the result of learning and training, as a mental habit and psychological strength.⁴⁷ Students' critical thinking development is based on learning

cognitive processes,^{48,49} and the level of engagement in learning affects critical thinking as a learning outcome. Studies have also found a statistically significant relationship between the development of critical thinking and students' engagement in learning, research, and extracurricular activities, with higher levels of engagement corresponding to greater critical thinking skills.¹² The second view suggests that critical thinking positively predicts study engagement.^{15,16} According to the drive theory of behavior, drives motivate or drive individual behavior to satisfy needs and eliminate tension. Individuals with high levels of critical thinking tendencies also have high levels of curiosity and the desire to learn, and the cognitive drive created by both positively influences college students' study engagement levels. It has been found that critical thinking is a key antecedent variable influencing students' learning process.¹⁶ Critical thinking disposition not only directly and significantly predicts study engagement, but also influences study engagement through mastery approach goal orientation and academic self-efficacy forming a chain of mediators.¹⁵ The third view suggests that study engagement and critical thinking predict each other.^{17,31} In the presage-process-product 3P model of learning proposed by Biggs, the interaction between the presage, process and outcome variables has formed a dynamic system.^{50,51} Study engagement as learning processes has formed the learning outcomes of critical thinking.⁴⁷ The two may interact dynamically. Study engagement influences learning outcomes, which in turn influence learning perceptions and study engagement.^{11,52} As mentioned earlier, cognitive deep processing is a cognitive level of study engagement.³⁴ Findings have also shown that critical thinking interacts with students' mastery achievement goals, self-efficacy and cognitive deep processing.^{17,31} Meanwhile, study engagement and critical thinking influence each other.

Previous studies have been conducted mainly based on cross-sectional data, and it is difficult to effectively determine the causal relationship between study engagement and critical thinking. Therefore, in order to further explore the relationship between study engagement and critical thinking, this study used a cross-lagged model to examine the causal relationship between them.

The Present Study

There is a lack of current research on the developmental trajectories of study engagement and critical thinking and the possible dynamic influence relationship between them, and a lack of longitudinal data used to demonstrate the causal relationship between study engagement and critical thinking. Therefore, this study focuses on two core research questions: (a) What are the developmental trajectories of learning engagement and critical thinking over time? How do the two influence each other? (b) What is the causal direction of the relationship between study engagement and critical thinking over time? Based on these two research questions, this study first explained the developmental trajectories of study engagement and critical thinking of Chinese higher vocational college students and the dynamic mechanisms of their mutual influence using a latent variable growth model. Then, a cross-lagged approach was adopted to reveal the causal relationship between study engagement and critical thinking. This study can help to theoretically explain the changes and effects of study engagement and critical thinking of Chinese higher vocational college students over time and to identify the causal relationships between them. In addition, this study offers some important insights into the way of enhancing higher vocational college students' study engagement and critical thinking from a practical perspective.

Methods

Participants and Procedure

A simple random sampling method was utilised to select 739 first-year students (mean age = 18.21 years, SD = 1.19 years) from a higher vocational institution in Shandong Province, China as valid subjects, including 477 female students (64.55%) and 262 male students (35.45%). All participants completed the questionnaire after the enrollment of the first year (Time1), after the first semester of the first year (Time2), and after the second semester of the first year (Time3). In the second data collection, 689 valid questionnaires were returned and collated (attrition rate = 6.766%, due to some students dropping out, transferring and incorrectly filling out information that could not be identified). A *t*-test of the first data from the second attrition and retention subjects revealed no significant difference between attrition and tracking subjects in terms of study engagement and critical thinking ($t = -1.773$, $p > 0.05$; $t = -1.211$, $p > 0.05$). In the third data collection, 654 valid questionnaires were returned and collated (attrition rate = 5.352%, for the same reasons mentioned

above). A *t*-test of the first data for the third attrition and retention subjects revealed no significant differences between attrition and tracking subjects in study engagement and critical thinking ($t = -1.677, p > 0.05$; $t = -0.821, p > 0.05$). This indicates that the subject attrition in this study was unstructured and the effect of attrition data on the study results was very minimal. The final sample with all three completed questionnaires was the final valid sample, with a sample size of 654, an average age of 18.11 ± 1.18 years, 35.321% male and 64.679% female, 61.162 are of rural or township origin, 16.208% for counties and 22.630% from urban areas, 41.131 were class leaders or student union leaders.

This study followed the principles of the Research Ethics Committee and was approved by the principal of the participating school. Participants were informed of the purpose of the study, the nature of voluntary participation, and how to withdraw from the survey. Informed consent was obtained for all participants prior to their participation in the study. After each survey, all participants received a small gift as compensation.

Measures

Self-report assessments were used to collect the data. All items for study engagement and critical thinking were measured on a 7-point Likert scale, ranging from 1 = absolutely disagree to 7 = absolutely agree. All the negatively worded questions were reverse coded. Participants also reported their demographic information at the three waves of data collection.

Study Engagement Measures

The Study Engagement Scale for College Students developed by Wang was used to measure the study engagement of higher vocational college students.⁵³ The scale was divided into five dimensions: active learning, teacher-student interaction, peer interaction, deep cognitive strategies, and enthusiasm for learning, with 22 questions [Appendix](#). For instance, “I will review what the teacher has taught in class in time”, “I am willing to work with my classmates to complete the homework assigned by the teacher” and “I would like to raise questions about what I have learned” et al. All the questions in this scale were positive. The sum of all the scores was calculated. The higher the score, the higher the degree of learning engagement of the students. In this study, the Cronbach’s alpha coefficients for questionnaires were 0.847 at Time 1, 0.889 at Time 2 and 0.901 at Time 3, which conformed to the critical value that Cronbach’s alpha coefficients of scale measurement should be above 0.55 in social science research put forward by Ziegel et al.⁵⁴

Critical Thinking Measures

The Critical Thinking Ability Scale developed by Peng et al was applied to measure the critical thinking abilities of higher education students.⁵⁵ The scale was divided into 7 dimensions, including truth-seeking, open-mindedness, analytical ability, systematization ability, self-confidence in critical thinking, intellectual curiosity and cognitive maturity, with a total of 70 questions [Appendix](#). For example, “When faced with a controversial topic, it is extremely difficult for me to choose between different opinions”, “It is important for me to know what others think about things”, “I get anxious when others only use shallow arguments to defend good ideas” and “I always analyze the point of the question before I answer it.” Some of the questions were reverse questions, and the scores were calculated by reversing the scores of these questions and then summing them with other positive questions. The higher the final score obtained, the better the student’s critical thinking skills. In this study, the Cronbach’s alpha coefficients for questionnaires were 0.971 at Time1, 0.965 at Time2 and 0.962 at Time3.

Data Analysis

First, this study mainly employed SPSS 26.0 and Mplus 8.3 for data processing. The descriptive statistics of the variables and their correlation coefficients were tested to examine the stability of study engagement and critical thinking among higher vocational college students and the correlation between them at different time points.

Second, to explore the relations among the initial level of study engagement, developmental trajectories of study engagement, the initial level of critical thinking, and the developmental trajectories of critical thinking, we constructed a latent growth model with parallel processes that examined relations among the intercepts of study engagement and critical thinking as well as the slope of study engagement and critical thinking.⁵⁶ The advantage of latent growth model is that it provides richer information by allowing the use of multi-wave data and takes into account systematic individual differences in change.⁵⁷ Furthermore, the relations between different domains (eg, study engagement and critical

thinking) can be computed using the latent growth model. Thus, using latent growth model analysis enabled accurate determination of the trajectory for each individual and examination of the relations between study engagement and critical thinking over the time. According to Muthén and Muthén, the latent growth model with parallel processes follows two steps: (a) estimate a growth model for each process separately, (b) conduct joint analysis of both processes.⁵⁶ The proposed models for the research procedures are presented in Figures 1–3. In these models, the paths from intercept factors to observed variables were constrained to 1, which means that the intercept values remained constant across three measurement times for each individual.⁵⁷ Additionally, the paths from slope factors to the observed variables were constrained to 0, 1, and 2, indicating that the second factor can be interpreted as a slope.⁵⁷

Third, we constructed a cross-lagged model of study engagement and critical thinking to further examine the causal relationship between the two. For the cross-lagged model, we not only tested whether the hypothesis models can act as a good fit for our data but also evaluated nested models (M1–M3). As shown in Figure 4, Model 1 supposed significant auto-regressive relationships between study engagement and critical thinking as well as reciprocal relationships (the baseline model). However, Models 2 and 3 assumed a single-lagged relationship between study engagement and critical thinking. Model 2 supposed that critical thinking at Time 1 and Time2 influences study engagement across time (freely estimated), and the path coefficient from study engagement to critical thinking was fixed to zero. Model 3 assumed that study engagement at Time 1 and Time 2 influences critical thinking across time (freely estimated); the path coefficient from critical thinking to study engagement was fixed to zero. Model 4 was a cross-lagged model containing all paths of models 1, 2 and 3. Model 4 was compared with Models 1, 2 and 3 to determine the model that best fits the data.

We used Mplus to conduct the analyses of model fit. All parameters were estimated using the full information maximum likelihood method. In addition, according to Hu and Bentler (1999), the fit indices and acceptable thresholds for model evaluation are χ^2 , df, CFI > 0.900, TLI > 0.900, RMSEA < 0.080, and SRMR < 0.08, respectively, but χ^2 has not been used to evaluate the fit of model because it was too sensitive to sample size.⁵⁸

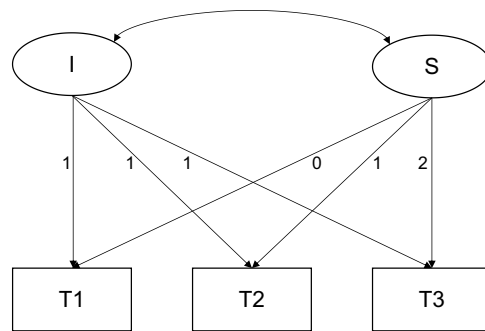

Figure 1 LGM with unconditional variables of study engagement or critical thinking.
Abbreviations: LGM, latent growth model; I, intercept; S, slope; T1, T2, T3, Time 1, Time 2, Time 3.

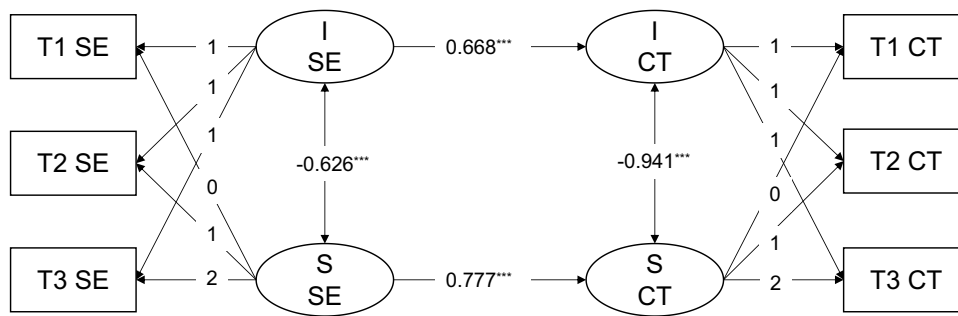

Figure 2 LGM of study engagement and critical thinking.
Note: *** p<0.001.
Abbreviations: LGM, latent growth model; I SE, intercept of study engagement; S SE, slope of study engagement; I CT, intercept of critical thinking; S CT, slope of critical thinking; T1, T2, T3, Time 1, Time 2, Time 3.

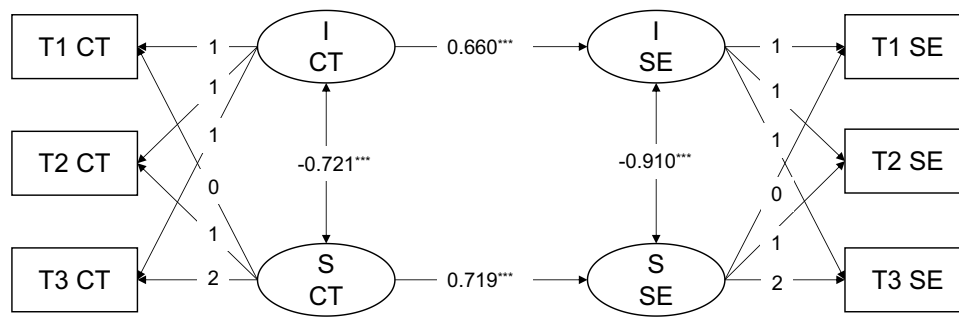

Figure 3 LGM of critical thinking and study engagement.

Note: *** $p < 0.001$.

Abbreviations: LGM, latent growth model; I CT, intercept of critical thinking; S CT, slope of critical thinking; I SE, intercept of study engagement; S SE, slope of study engagement; T1, T2, T3, Time 1, Time 2, Time 3.

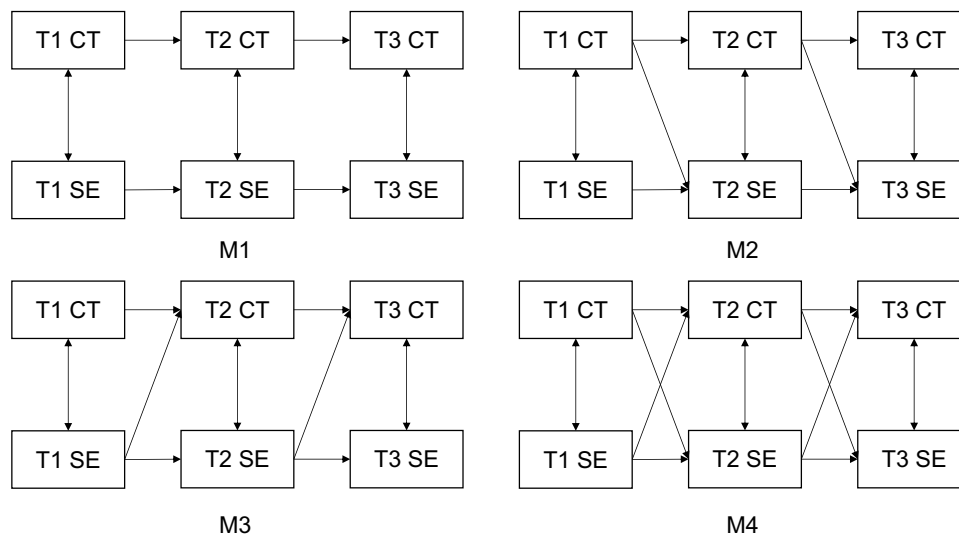

Figure 4 Nested models of the relationship between study engagement and critical thinking.

Abbreviations: SE, study engagement; CT, critical thinking; T1, T2, T3, Time 1, Time 2, Time 3.

Results

Common Method Deviation

The data used in this study was collected using the students' self-report method, which might have some common method bias issues. Based on the suggestion of Podsakoff et al, the Harman one-way test was used to test for common method bias for each of the three measurements.⁵⁹ The results showed that the amount of variance explained by the first factor was 30.41%, 31.45%, and 25.06% respectively in the order of the three tests, all of which were less than the critical criterion of 40%, which indicated that there was no significant common method bias in the data of this study.

Descriptive Statistics and Correlation Analysis

The means, standard deviations, and correlation coefficient matrices of study engagement and critical thinking of higher vocational college students for the three measurements were shown in Table 1. The results found that study engagement and critical thinking were significantly and positively correlated from T1 to T3 ($r_s = 0.202-0.439$, $p_s < 0.01$); study engagement was pairwise correlation at each time point ($r_s = 0.298-0.481$, $p_s < 0.01$), and critical thinking was also pairwise correlation ($r_s = 0.306-0.452$, $p_s < 0.01$). This suggested that the simultaneous correlations and stability of study engagement and critical thinking among higher vocational students were generally consistent and suitable for latent growth model and cross-lagged model analysis.

Table 1 Means, Standard Deviations, and Correlations Among Main Measures

Variable	M(SD)	1	2	3	4	5	6
1.T1 CT	4.284(0.399)	1.000					
2.T2 CT	4.207(0.366)	0.481**	1.000				
3.T3 CT	4.174(0.340)	0.298**	0.352**	1.000			
4.T1 SE	4.559(0.992)	0.343**	0.274**	0.202**	1.000		
5.T2 SE	4.399(0.857)	0.314**	0.370**	0.242**	0.452**	1.000	
6.T3 SE	4.332(0.808)	0.238**	0.274**	0.439**	0.306**	0.413**	1.000

Note: ** $p < 0.01$.

Developmental Trajectories of Study Engagement and Critical Thinking Unconditional Latent Growth Model for Study Engagement

A linear unconditional latent growth model as shown in Figure 1 was constructed for higher vocational college students' study engagement to examine the trajectories of study engagement during their first year of college. The fit indices of study engagement ($\chi^2/df = 2.420$, CFI = 0.995, TLI = 0.985, RMSEA = 0.047, SRMR = 0.014) showed that the unconditional model fitted the data well. In the linear unconditional latent variable growth model for study engagement, the intercept of the model, ie, the initial level of study engagement was 4.540 (SE = 0.037, $p < 0.001$), which was significantly greater than 0. The slope of the model, ie, the trajectories of study engagement decreased linearly over the three measurement periods (Slope = -0.011 , SE = 0.021, $p < 0.001$).

In addition, the variance estimates for the intercept factor ($\sigma^2 = 0.522$, SE = 0.064, $p < 0.001$) and the slope factor ($\sigma^2 = 0.089$, SE = 0.028, $p < 0.001$) were both significant at the 0.001 level, indicating that there were significant inter-individual differences in the initial level and the rate of decline in study engagement over time. Finally, there was a significant correlation between the intercept growth factor and the slope growth factor ($r = -0.642$, $p < 0.001$), making clear that the higher the initial level of study engagement, the faster the level of study engagement declined over the three measurement periods (see Table 2).

Unconditional Latent Growth Model for Critical Thinking

To examine the trajectory of changes in the development of critical thinking among higher vocational college students during their first year of college, this study similarly constructed a linear unconditional latent growth model as shown in Figure 1. The fit indices for critical thinking ($\chi^2/df = 3.024$, CFI = 0.993, TLI = 0.978, RMSEA = 0.056, SRMR = 0.014) showed that the unconditional model fitted the data well. In the linear unconditional latent growth model for critical thinking, the intercept of the model, ie, the initial level of critical thinking, was 4.279 (SE = 0.015, $p < 0.001$), which was significantly greater than 0. The slope of the model, ie, the trajectories of critical thinking, decreased linearly over the 3 measurements (Slope = -0.056 , SE = 0.009, $p < 0.001$). In addition, the variance estimates for the intercept factor ($\sigma^2 = 0.100$, SE = 0.011, $p < 0.001$) and the slope factor ($\sigma^2 = 0.016$, SE = 0.005, $p < 0.05$) were significant at the 0.05 level, indicating significant inter-individual differences in the initial level of critical thinking and the rate of decline in critical thinking over time. Finally, there was a significant correlation between the intercept growth factor and the slope growth factor ($r = -0.734$, $p < 0.001$), showing that the higher the initial level of critical thinking, the faster the students' level of critical thinking decreased during the three measurements (see Table 2).

Table 2 Coefficient and Fit Indices of Unconditional Latent Growth Model of SE and CT

Model	Fit Indices					Coefficients		Variance	
	χ^2/df	CFI	TFI	SRMR	RMSEA	Intercept	Slope	Intercept	Slope
SE	2.420	0.995	0.985	0.014	0.047	4.540***	-0.011***	0.522***	0.089***
CT	3.024	0.993	0.978	0.014	0.056	4.279***	-0.056***	0.100***	0.016*

Note: * $p < 0.05$; *** $p < 0.001$.

Abbreviations: CT, critical thinking; SE, study engagement; T1, T2, T3, Time 1, Time 2, Time 3.

Latent Growth Model with Parallel Processes of Study Engagement and Critical Thinking

To examine the influence processes between study engagement and critical thinking among higher vocational college students, this study constructed a latent growth model with parallel processes to investigate the potential growth of study engagement and critical thinking simultaneously. First, we used the intercept and slope in the study engagement model to predict a linear decline in critical thinking. The model fitted well with $\chi^2(7) = 3.594$, CFI = 0.978, TLI = 0.952, RMSEA = 0.063, SRMR = 0.023, which was suitable for the next step of analysis. In the latent growth model with parallel processes of study engagement and critical thinking, the regression results were shown in Figure 2. The slope of study engagement positively predicted the slope of critical thinking, $\beta = 0.668$, SE = 0.070, $p < 0.001$, showing that the faster the level of study engagement declined over time, the faster the level of critical thinking of the students declined. Moreover, the intercept of study engagement positively predicted the intercept of critical thinking, $\beta = 0.777$, SE = 0.209, $p < 0.001$, suggesting that the higher the initial level of study engagement of the students, the higher their initial level of critical thinking. In addition, the correlation coefficient between the intercept growth factor of study engagement and the slope growth factor was -0.626 ($p < 0.001$), showing that there was a negative correlation between the initial level of study engagement and the rate of development, and that the higher the initial level of study engagement, the faster it declined. The correlation coefficient between the intercept growth factor and the slope growth factor for critical thinking was -0.941 ($p < 0.001$), making clear that there was a negative correlation between the initial level of critical thinking and the rate of development, and that the higher the initial level of critical thinking, the faster it decreased.

Then, to further test the causal relationship between study engagement and critical thinking and whether there is an interaction between the two, this study adjusted the order of the independent and dependent variables to develop a latent growth model with the parallel processes of critical thinking and study engagement, using the slope and intercept of critical thinking to predict a linear decline in study engagement. The model fitted well with $\chi^2(7) = 3.594$, CFI = 0.978, TLI = 0.952, RMSEA = 0.063, SRMR = 0.023, which was suitable for the next step of analysis. In the latent growth model with parallel processes of critical thinking and study engagement, the regression results were shown in Figure 3. The slope of critical thinking positively predicted the slope of study engagement, $\beta = 0.660$, SE = 0.098, $p < 0.001$, suggesting that the faster the level of critical thinking decreased over time, the faster the level of students' study engagement decreased. Meanwhile, the intercept of critical thinking positively predicted the intercept of study engagement, $\beta = 0.719$, SE = 0.291, $p < 0.001$, indicating that the higher the initial level of critical thinking of students, the higher their initial level of study engagement. In addition, the correlation coefficient between the intercept growth factor of study engagement and the slope growth factor was -0.910 ($p < 0.001$), showing that there was a negative correlation between the initial level of study engagement and the rate of development, and that the higher the initial level of study engagement, the faster it declined. The correlation coefficient between the intercept growth factor and the slope growth factor for critical thinking was -0.721 ($p < 0.001$), making clear that there was a negative correlation between the initial level of critical thinking and the rate of development, and that the higher the initial level of critical thinking, the faster it decreased.

Cross-Lagged Model Analysis

After the initial finding of a bidirectional causal relationship between study engagement and critical thinking in the latent growth model with parallel processes of study engagement and critical thinking, in order to further test to prove the causal relationship between study engagement and critical thinking, this study conducted a cross-lagged analysis of study engagement and critical thinking measured in 3 waves, as suggested by Martens and Haase.⁶⁰ Before conducting the cross-lagged analysis of the relationship between the variables, as shown in Figure 4, the fit indices of the four models were first examined for comparison. Table 3 showed the fit indices of the four models of the current study and the results of the cardinal differences between each competing model (M1, M2 and M3) and the full model (M4). From the table, the fit indices of M4 were all better than M1, M2 and M3, and the chi-square differences between M4 and M1 ($\Delta\chi^2 = 66.285$, $\Delta df = 4$, $p < 0.001$), M4 and M2 ($\Delta\chi^2 = 22.459$, $\Delta df = 2$, $p < 0.001$), and M4 and M3 ($\Delta\chi^2 = 37.291$, $\Delta df = 2$, $p < 0.001$) were all significant. The above results suggested that M4 was the best model.

Table 3 The Goodness-of-Fit Statistics for the Nested Models

model	χ^2	df	CFI	TLI	SRMR	RMSEA	Model Comparisons	$\Delta\chi^2$	Δ df	p
M1	88.746	8	0.889	0.805	0.124	0.124	M4 vs.M1	66.285	4	<0.001
M2	44.920	6	0.946	0.875	0.069	0.100	M4 vs.M2	22.459	2	<0.001
M3	59.752	6	0.926	0.827	0.094	0.117	M4 vs.M3	37.291	2	<0.001
M4	22.461	4	0.975	0.911	0.037	0.084				

Discussion

Our study found that Chinese higher vocational college students' study engagement declined continuously during their first year of university, which was consistent with the research conducted by Zhang & Wang who found a decline in Chinese college students' study engagement from freshman year and a low lying phenomenon at the sophomore stage.³⁷ This may be due to the fact that in China, where the national unified college entrance examination exerts too much pressure on high school students, the study engagement of students who have just entered the college has continued the high engagement status obtained during their high school years. However, university studies are less stressful than high school studies and the environment is more relaxed. Moreover, as students become familiar with the university after enrollment, their life circle will be gradually extended, and their energy will be naturally distributed to other activities other than studies. This can lead to a constant distraction of students' energy from their studies and a decrease in their commitment. The current results also indicate that the initial level of study engagement and the rate of decline are negatively correlated, suggesting that students with higher initial levels of study engagement had a faster rate of decline during their first year of college; conversely, students with lower initial levels of study engagement had a slower rate of decline during their first year of college. This may be a stress-release effect: students with high levels of study engagement under pressure in high school may be more likely to relax and devote their energy to other areas when they enter the relaxed environment of university, resulting in a greater rate of decline in study engagement.

Our study discovered that Chinese higher vocational college students' critical thinking declined continuously during their first year of college. This was consistent with previous research findings with a sample of Chinese college students, who started at a high level of critical thinking performance,⁵² but were on a downward trajectory after entering college and were at a low point during their sophomore year.⁴⁵ The current results also showed that the initial level of critical thinking and the rate of decline are negatively correlated, suggesting that students with higher initial levels of critical thinking had a faster rate of decline in their level of study engagement during their first year of college; conversely, students with lower initial levels of critical thinking had a slower rate of decline in their level of study engagement during their first year of college. The reason for this may be that most of the teaching objectives adopted in higher vocational institutions are aimed at developing proficiency in vocational skills instead of fostering or encouraging students' critical thinking. In addition, during the first year of college, many courses are basic in nature and the content of which is mainly about indoctrination and may not stimulate students' curiosity or analytical thinking. Courses that stimulate analytical thinking and critical analysis are more often set to occur in the second or third year.

Our results suggested that the initial level of study engagement positively predicted the initial level of critical thinking, and the initial level of critical thinking in turn positively predicted the initial level of study engagement. That is, individuals with higher levels of study engagement have higher levels of critical thinking, and individuals with higher levels of critical thinking have higher levels of study engagement. This may be related to the nature of learning and the mechanism of action of critical thinking. Modern cognitive psychology tells us that learning and training is a constructive process,⁶¹ not a receptive process, and that understanding comes from the interaction of experience and environment. Moreover, learners build new understanding and reflection on the basis of prior knowledge, forming critical thinking, which means that learning is mainly constructed and understood by the learner, and that the input of the individual learner plays an important role in influencing the formation of critical thinking. Additionally, critical thinking dispositions as stable ways of thinking about learning determine the level or hierarchy of independent thinking, reasoning, and

decision making, which enable students to assess and analyze learning materials in the classroom with comprehension and analytical thinking and promote students' engagement in study.^{62,63}

Furthermore, our study showed that the slope of study engagement positively predicted the slope of critical thinking, and the slope of critical thinking positively predicted the slope of study engagement. That is, the faster the rate of decline in study engagement, the faster the rate of decline in critical thinking, and similarly, the faster the rate of decline in critical thinking, the faster the rate of decline in study engagement. This was consistent with previous research findings: there is a significant bidirectional effect between critical thinking and the deep learning approach,³¹ which is a cognitive level of study engagement.³⁴ In other words, there is a significant bidirectional effect between critical thinking and study engagement. The reason for this may be related to self-efficacy, which is an influencing factor of the deep learning approach.^{64,65} These studies suggested that critical thinking can act as a self-regulator and motivate individuals to perform, ie, critical thinking skills can help to enhance students' self-efficacy and contribute to an increasing preference for deep learning over time. As the level of deep learning increases rapidly, it becomes easier to develop critical thinking as a learning outcome. Thus, there is a reciprocal positive effect of the rate of change in study engagement and the rate of change in critical thinking.

Finally, the current study further confirmed the causal relationship between study engagement and critical thinking through cross-lagged regression analysis. The results indicated that study engagement positively predicted critical thinking, and critical thinking positively predicted study engagement, and there was a reciprocal relationship between the two. The present results do not imply a rejection of the first and second previous views, but rather an integration of these two views and support the third view that good study engagement fosters critical thinking and that students with good critical thinking will in turn increase study engagement. Conversely, lower study engagement is not conducive to the formation of critical thinking, which will further reduce study engagement and form a vicious circle. This provides a clear direction for the learning and development of higher vocational college students. Cultivating either aspect of study engagement and critical thinking can help to break the vicious circle relationship between study engagement and critical thinking. For example, higher vocational education should strive to create positive learning environments to improve students' learning experiences and increase their study engagement; invest resources in activities that significantly improve learning and increase support for all aspects of student learning (eg social activities, foreign language, competition, lectures, social practice support). The curriculum should focus on motivating students to devote time and energy to learning-related activities and to improve their critical thinking by increasing their study engagement. Teachers should also pay more attention to the quality of classroom instruction and strive to improve the organizational design of instruction, such as explaining instructional objectives and requirements more clearly, encouraging discussion, communication, and reflection, which can foster students' critical thinking and also enhance students' study engagement.

Limitations and Future Directions

Though this study has provided important findings, there are some limitations. First, the sample in this study was drawn from only one Chinese higher vocational institution. Although the sample size was large, the sample might be under-represented. Future studies should enrich the heterogeneity of the sample and expand the scope of application of the findings. Second, the longitudinal follow-up time of the sample in this study was insufficient. Most of the higher vocational institutions in China have 3 years of study, but this study only tracked 1 year of data, and the results can only present 1 year of development. In the future, we should continue to track the data to completely study the developmental trajectories and interplay between study engagement and critical thinking throughout the entire attendance cycle of Chinese higher vocational college students. Third, the data collected in this study was heavily dependent on student self-reported data, which was only an indirect indicators of college student learning. Therefore, appropriate caution should be exercised in interpreting these results. Additional data sources, such as student interviews, faculty reports, paper-and-pencil assessments, and observations, should be added to future studies to supplement the self-reported data. Finally, further research is required to explore other variables that influence study engagement and critical thinking trajectories (eg nature of activities, tasks or requirements in courses, etc.) in order to provide a clearer perspective on the study of learning engagement and critical thinking.

Conclusions

This study used a latent growth model with cross-lagged regression analysis to explore the developmental trajectories of study engagement and critical thinking among Chinese higher education students, as well as the longitudinal interactions between study engagement and critical thinking. Our findings indicate that (a) students' study engagement and critical thinking declined during their first year of higher education in China. (b) The intercept and slope of study engagement can positively affect the intercept and slope of critical thinking respectively, and the intercept and slope of critical thinking in turn can positively affect the intercept and slope of study engagement respectively. (c) The cross-lagged regression analysis further verified that study engagement and critical thinking can positively influence each other. The results can help researchers and educators to develop a developmental perspective on study engagement and critical thinking in higher vocational students. Developing either aspect of study engagement and critical thinking can contribute to the joint improvement of both levels. Higher vocational college should try hard to create a positive learning environment to improve students' learning experience and increase their study engagement; invest resources in activities that significantly improve learning and increase support for all aspects of student learning; and focus curriculum on motivating students to invest time and energy in learning-related activities. Teachers should also pay more attention to the quality of classroom teaching, strive to improve the organizational design of teaching, and encourage discussion, communication and reflection, which can develop students' critical thinking.

Ethics Approval and Consent to Participate

This study was approved by the Ethics Committee of Qingdao harbor vocational and technical college and was conducted in accordance with the Declaration of Helsinki.

Acknowledgments

We are grateful to the school administrators, teachers and students who actively cooperated with the researchers to collect data.

Funding

This study received funding from the Youth Project on Education supported by the National Social Science Fund of China "Research on the motivation and guarantee mechanism of enterprises' participation in school running under the mixed ownership reform of higher vocational colleges" (CIA220278).

Disclosure

The authors report no conflicts of interest in this work.

References

1. Trilling B, Fadel C. *21st Century Skills: Learning for Life in Our Times*. John Wiley & Sons; 2009:50–53.
2. Ermis RH. Critical thinking: a streamlined conception. *Teach Philos*. 1991;14(1):5–25. doi:10.5840/teachphil19911412
3. Hart Research Associates. Recent trends in general education design, learning outcomes, and teaching approaches: key findings from a survey among administrators at AAC&U member institutions; 2016. Available from: https://dmgm81phhv63.cloudfront.net/content/user-photos/Research/PDFs/2015_Survey_Report2_GETrends.pdf. Accessed October 6, 2022.
4. Whorton R, Casillas A, Oswald FL, Shaw A. Critical skills for the 21st century workforce. In: Burrus J, Mattern KD, Naemi B, Roberts RD, editors. *Building Better Students: Preparation for the Workforce*. NY: Oxford University Press; 2017:47–72.
5. Halpern DF. *Thought and Knowledge: An Introduction to Critical Thinking*. Psychology Press; 2013:23–24.
6. Yang SA. Critical thinking disposition and problem solving ability in nursing students. *J Korean Acad Nurs Admin*. 2010;16(4):389–398. doi:10.11111/jkana.2010.16.4.389
7. Ku KY, Ho IT. Metacognitive strategies that enhance critical thinking. *Metacognition Learn*. 2010;5(3):251–267. doi:10.1007/s11409-010-9060-6
8. Pithers RT, Soden R. Critical thinking in education: a review. *Educ Res*. 2000;42(3):237–249. doi:10.1080/001318800440579
9. Wan ZH, Wan SL, Zhan Y. For harmony and democracy: secondary students' views on the value of developing critical thinking in a Confucian heritage context Thinking Skills and Creativity; 2022. Available from: <https://www.sciencedirect.com/science/article/abs/pii/S1871187122000347>. Accessed October 6, 2022.
10. Aktoprak A, Hursen C. A bibliometric and content analysis of critical thinking in primary education. *Thinking skills and creativity*; 2022. Available from: <https://www.sciencedirect.com/science/article/abs/pii/S1871187122000323>. Accessed October 6, 2022.
11. Giacomazzi M, Fontana M, Trujillo CC. Contextualization of critical thinking in sub-Saharan Africa: a systematic integrative review. *Thinking skills and creativity*; 2022. Available from: <https://www.sciencedirect.com/sdfe/arp/cite?pii=S1871187121001930&format=text%2Fx-bibtex&withabstract=true>. Accessed October 6, 2022.

12. Shcheglova I, Koreshnikova Y, Parshina O. The role of engagement in the development of critical thinking in undergraduates. *Educ Stud.* 2019;2019(1):264–289.
13. Kuhn D. A developmental model of critical thinking. *Educ Res.* 1999;28(2):16–46. doi:10.3102/0013189X028002016
14. Wylie C, Hodgen E. Trajectories and patterns of student engagement: evidence from a longitudinal study. In: Christenson S, Reschly A, Wylie C, editors. *Handbook of Research on Student Engagement.* Boston, MA: Springer; 2012:585–599.
15. Lu ZY, Chen JW. College students' critical thinking tendency and learning engagement: the mediating role of achievement goal orientation and academic self-efficacy. *High Educ Res.* 2017;38(7):69–77. in Chinese.
16. Phan HP. Relations between goals, self-efficacy, critical thinking and deep processing strategies: a path analysis. *Educ Psychol.* 2009;29(7):777–799. doi:10.1080/01443410903289423
17. Liu ZK, He J, Li B. Critical and creative thinking as learning processes at top-ranking Chinese middle schools: possibilities and required improvements. *High Ability Stud.* 2015;26(1):139–152. doi:10.1080/13598139.2015.1015501
18. Coates H. The value of student engagement for higher education quality assurance. *Qual High Educ.* 2005;11(1):25–36. doi:10.1080/13538320500074915
19. Alfonso M, Bailey TR, Scott M. The educational outcomes of occupational sub-baccalaureate students: evidence from the 1990s. *Econom Educ Rev.* 2005;24(2):197. doi:10.1016/j.econedurev.2004.02.003
20. Sanchez JR, Laanan FS. Economic benefits of a community college education: issues of accountability and performance measures. *New Directions Commun Coll.* 1998;198(104):5–15. doi:10.1002/cc.10401
21. Wonacott ME. Benefits of vocational education. myths and realities No. 8; 2000. Available from: <https://files.eric.ed.gov/fulltext/ED441179.pdf>. Accessed October 6, 2022.
22. Norris SP, Ennis RH. *Evaluating Critical Thinking.* Pacific Grove, CA: Midwest Publications; 1989:3.
23. Barnett R. Higher education: a critical business. *Int J Educ Manage.* 1998;12(3):141.
24. U.S. Department of Education. A test of leadership: charting the future of U.S. higher education; 2006. Available from: <https://www.voced.edu.au/content/ngv:56421>. Accessed October 6, 2022.
25. AAC&U (Association of American Colleges and Universities). Fulfilling the American dream: liberal education and the future of work Hart Research Associates; 2018. Available from: <https://dgm81pnhvh63.cloudfront.net/content/user-photos/Research/PDFs/2018EmployerResearchReport.pdf>. Accessed October 6, 2022.
26. Halpern DF. Teaching for critical thinking: helping college students develop the skills and dispositions of a critical thinker. *New Directions Teach Learn.* 1999;(80):69–74. doi:10.1002/tl.8005
27. Kuhn D. *The Skills of Argument.* Cambridge, England: Cambridge University Press; 1991:8.
28. Bezanilla MJ, Fernández-Nogueira D, Poblete M, Galindo-Domínguez H. Methodologies for teaching-learning critical thinking in higher education: the teacher's view. Thinking skills and creativity; 2019. Available from: <https://www.sciencedirect.com/science/article/abs/pii/S1871187119300380>. Accessed October 6, 2022.
29. Behar-Horenstein LS, Niu L. Teaching critical thinking skills in higher education: a review of the literature. *J Coll Teach Learn.* 2011;8(2):25–41.
30. Coates H. Development of the Australasian survey of student engagement (AUSSE). *High Educ.* 2010;60(1):1–17. doi:10.1007/s10734-009-9281-2
31. Leung DYP, Kember D. The relationship between approaches to learning and reflection upon practice. *Educ Psychol.* 2003;23:61–71. doi:10.1080/01443410303221
32. Kahu ER. Framing student engagement in higher education. *Stud High Educ.* 2013;38:758–773. doi:10.1080/03075079.2011.598505
33. Zepke N. Student engagement research in higher education: questioning an academic orthodoxy. *Teach High Educ.* 2014;19:697–708. doi:10.1080/13562517.2014.901956
34. Fredricks JA, Blumenfeld PC, Paris AH. School engagement: potential of the concept, state of the evidence. *Rev Educ Res.* 2004;74:59–109. doi:10.3102/00346543074001059
35. Archambault I, Janosz M, Morizot J, Pagani L. Adolescent behavioral, affective, and cognitive engagement in school: relationship to dropout. *J School Health.* 2009;79:408–415. doi:10.1111/j.1746-1561.2009.00428.x
36. Zhang M, Ruolan L. Research on the influence of college students' professional identity on learning engagement: the mediating role of school belonging. *Heilongjiang Res High Educ.* 2018;2018(03):94–99. in Chinese.
37. Zhang YH, Wang CH. Characteristics of professional identity of free normal students in special education in Xinjiang and its relationship with relearning engagement: understanding the mediating role of social support. *Chin J Special Educ.* 2018;2018(03):58–64. in Chinese.
38. Pascarella ET, Terenzini PT. *How College Affects Students: A Third Decade of Research.* Jossey-Bass; 2005:10.
39. Pascarella ET, Salisbury MH, Blaich C. Exposure to effective instruction and college student persistence: a multi-institutional replication and extension. *J Coll Stud Dev.* 2011;52(1):4–19. doi:10.1353/csd.2011.0005
40. Bowman NA. Can 1st-year college students accurately report their learning and development? *Am Educ Res J.* 2010;47(2):466–496. doi:10.3102/0002831209353595
41. Roohr KC, Liu H, Liu OL. Investigating student learning gains in college: a longitudinal study. *Stud High Educ.* 2017;42(12):2284–2300. doi:10.1080/03075079.2016.1143925
42. Najafi M, Motlagh MK, Najafi M, Kashani AS, Zarghi N, Shirazi M. Trend of tendency to critical thinking among medical students in Tehran University of Medical Sciences, 2010–2015: a longitudinal study. *J Educ Health Promot.* 2022;11:29. doi:10.4103/jehp.jehp_1373_20
43. Zhang QG, Shen H. Re-examination of the value-added ability of Chinese undergraduates' critical thinking: also on the practical dilemma of value-added evaluation of higher education. *China High Educ Res.* 2022;2022(01):69–75. in Chinese.
44. Loyalka P, Liu OL, Li G, et al. Skill levels and gains in university STEM education in China, India, Russia and the United States. *Nat Human Behav.* 2021;5(7):892–904. doi:10.1038/s41562-021-01062-3
45. Xia HH, Zhong BL. Research on influencing factors and training strategies of college students' critical thinking. *Educ Res.* 2017;38(5):67–76. in Chinese.
46. Astin AW. Student involvement: a developmental theory for higher education. *J Coll Student Personnel.* 1984;25(4):297–308.
47. Sumner WG. *Folkways: A Study of the Sociological Importance of Usages, Manners, Customs, Mores, and Morals.* Good Press; 2019:57–62.
48. Raymond-Seniuk C, Profetto-McGrath J. Can one learn to think critically?—a philosophical exploration. *Open Nurs J.* 2011;5:45. doi:10.2174/1874434601105010045

49. Iranfar K, Iranfar S, Mohammadi G. Developing critical thinking disposition in the students of nursing and midwifery through collaborative and individual methods of learning. *HealthMED*. 2012;6(12):4047–4052.
50. Biggs JB. From theory to practice: a cognitive systems approach. *High Educ Res Dev*. 1993;12(1):73–85. doi:10.1080/0729436930120107
51. Biggs J, Kember D, Leung DY. The revised two-factor study process questionnaire: r-SPQ-2F. *Br J Educ Psychol*. 2001;71(1):133–149. doi:10.1348/000709901158433
52. Llorens S, Schaufeli W, Bakker A, Salanova M. Does a positive gain spiral of resources, efficacy beliefs and engagement exist? *Comput Human Behav*. 2007;23:825–841. doi:10.1016/j.chb.2004.11.012
53. Wang YS. *An Empirical Study on College Students' Learning Engagement: Based on the Data Analysis of "National College Students' Learning Survey"*. Xiamen University; 2014:187–188. in Chinese.
54. Ziegel ER, Hatcher L, Stepanski E. A stepby-step approach to using the SAS system for univariate and multivariate statistics. *Technometrics*. 2005;37(4):471.
55. Peng MC, Wang GC, Chen JL, et al. Validity and reliability of the Chinese critical thinking disposition inventory. *Chin J Nurs*. 2004;2004(09):7–10. in Chinese.
56. Muthén LK, Muthén B. Growth modeling with latent variables using Mplus: introductory and intermediate growth models. 2012:170–182. Available from: <http://www.statmodel.com/download/Topic3-v.pdf>. Accessed October 6, 2022.
57. Byrne BM. *Structural Equation Modeling with AMOS: Basic Concepts, Applications, and Programming*. 3rd ed. Routledge; 2016:266–267.
58. Asparouhov T, Muthén B, Muthén BO. Robust chi square difference testing with mean and variance adjusted test statistics. *Matrix*. 2006;1(5):1–6.
59. Podsakoff PM, MacKenzie SB, Lee JY, Podsakoff NP. Common method biases in behavioral research: a critical review of the literature and recommended remedies. *J Appl Psychol*. 2003;88(5):879–903. doi:10.1037/0021-9010.88.5.879
60. Martens MP, Haase RF. Advanced applications of structural equation modeling in counseling psychology research. *Counsel Psychol*. 2006;34(6):878–911. doi:10.1177/0011000005283395
61. Von Glasersfeld E. Learning as a constructive activity, problems of representation in the teaching and learning of mathematics. Proceedings of the 5th annual meeting of the North American group of psychology in mathematics education. 1983:41–101.
62. Mezirow J. How critical reflection triggers transformative learning. *Foster Crit Reflect Adulthood*. 1990;1(20):1–6.
63. Kish CK, Sheehan JK, Cole KB, et al. Portfolio in the classroom: a vehicle for developing reflective thinking. *High School J*. 1997;80:254–260.
64. Fenollar P, Roman S, Cuestas PJ. University students' academic performance: an integrative conceptual framework and empirical analysis. *Br J Educ Psychol*. 2007;77:873–891. doi:10.1348/000709907X189118
65. Greene BA, Miller RB. Influences on achievement: goals, perceived ability, cognitive engagement. *Contemp Educ Psychol*. 1996;21:181–192. doi:10.1006/ceps.1996.0015

Psychology Research and Behavior Management

Dovepress

Publish your work in this journal

Psychology Research and Behavior Management is an international, peer-reviewed, open access journal focusing on the science of psychology and its application in behavior management to develop improved outcomes in the clinical, educational, sports and business arenas. Specific topics covered in the journal include: Neuroscience, memory and decision making; Behavior modification and management; Clinical applications; Business and sports performance management; Social and developmental studies; Animal studies. The manuscript management system is completely online and includes a very quick and fair peer-review system, which is all easy to use. Visit <http://www.dovepress.com/testimonials.php> to read real quotes from published authors.

Submit your manuscript here: <https://www.dovepress.com/psychology-research-and-behavior-management-journal>