





ORIGINAL RESEARCH

Comprehensive Physiological Modeling Provides Novel Insights Into Heart Failure With Preserved Ejection Fraction Physiology

David M. Kaye , MD, PhD; Emil Wolsk, MD; Shane Nanayakkara , MD, PhD; Justin Mariani, MD, PhD; Christian Hassager, MD, DMSc; Finn Gustafsson , MD, PhD; Jacob E. Moller, MD, PhD; Kenji Sunagawa, MD, PhD; Daniel Burkhoff , MD, PhD

BACKGROUND: Although a rapid rise in left atrial pressure during exertion is considered pathognomonic of heart failure with preserved ejection fraction (HFpEF), the fundamental circulatory determinants of this response are not clear, impacting upon the development of more effective therapies. We aimed to comprehensively describe the circulatory mechanics of patients with HFpEF at rest and during exercise in comparison with controls.

METHODS AND RESULTS: We performed simultaneous right-heart catheterization and echocardiography at rest and during exercise in 22 healthy control volunteers and 60 patients with confirmed HFpEF. Using detailed individual patient-level hemodynamic and left ventricular ejection fraction data we performed computer simulations to evaluate the circulatory parameters including the estimated stressed blood volume that contribute to the resting and exercise pulmonary capillary pressure. At rest and during exercise, left ventricular stiffness (V_{30} , the end-diastolic pressure–volume relationship at a filling pressure of 30 mm Hg), left ventricular elastance, and arterial elastance were all significantly greater in HFpEF than in controls. Stressed blood volume was significantly greater in HFpEF (26.9 ± 5.4 versus 20.2 ± 4.7 mL/kg, $P < 0.001$), becoming even more pronounced during exercise (40.9 ± 3.7 versus 27.5 ± 7.0 mL per 70 kg, $P < 0.001$). During exercise, the magnitude of the change in stressed blood volume ($r = 0.67$, $P < 0.001$) and left ventricular stiffness ($r = -0.44$, $P < 0.001$) were key determinants of the rise in pulmonary capillary wedge pressure. Further detailed modeling studies showed that the hemodynamic response to exercise results from a complex non-linear interaction between circulatory parameters.

CONCLUSIONS: The circulatory determinants of HFpEF physiology are complex. We identified stressed blood volume at rest and during exercise is a novel, key factor, thereby representing an important potential therapeutic target.

Key Words: circulation ■ computer modeling ■ heart failure with preserved ejection fraction ■ physiology

The diagnosis of heart failure with preserved ejection fraction (HFpEF) is based upon the presence of a left ventricular ejection fraction (LVEF) $> 50\%$, signs and symptoms of heart failure, together with supportive investigations including natriuretic peptide levels or echocardiography. Unlike heart failure with reduced ejection fraction, the diagnosis of HFpEF can be challenging given that in some cases natriuretic peptide levels may be normal and echocardiographic

indices may be of indeterminate significance.^{1,2} In such cases, stress hemodynamic investigation has proven to be the gold-standard diagnostic approach.^{3,4} Key characteristics of hemodynamic responses to exercise in patients with HFpEF compared with normal subjects include marked elevations of pulmonary capillary wedge pressure (PCWP), central venous pressure (CVP), and reduced cardiac output (CO) reserve.

Correspondence to: David M. Kaye MD, PhD, Heart Failure Research Group, Baker Heart and Diabetes Institute, PO Box 6492, Melbourne, Victoria 3004, Australia. E-mail: david.kaye@baker.edu.au

Supplementary Material for this article is available at <https://www.ahajournals.org/doi/suppl/10.1161/JAHA.121.021584>

For Sources of Funding and Disclosures, see page 11.

© 2021 The Authors. Published on behalf of the American Heart Association, Inc., by Wiley. This is an open access article under the terms of the Creative Commons Attribution-NonCommercial-NoDerivs License, which permits use and distribution in any medium, provided the original work is properly cited, the use is non-commercial and no modifications or adaptations are made.

JAHA is available at: www.ahajournals.org/journal/jaha

CLINICAL PERSPECTIVE

What Is New?

- Elevated left atrial pressure is a hallmark feature in patients with heart failure with preserved ejection fraction, most notably during exercise.
- To date, the detailed physiologic basis for this characteristic has remained uncertain.
- Computer simulations based on invasive exercise hemodynamic data and echocardiography demonstrate a key contribution from an increase in the stressed blood volume together with an increase in left ventricular stiffness.

What Are the Clinical Implications?

- This study highlights the complex nature of the individual circulatory determinants of heart failure with preserved ejection fraction physiology. Our study demonstrates the use of computer modeling to investigate the contribution of multiple dynamic mechanical parameters, including the stressed blood volume which cannot be readily measured clinically.
- Our data identified the stressed blood volume and left ventricular stiffness as key contributors to the physiological profile of heart failure in patients with preserved ejection fraction and therefore highlights them as key targets for therapy.

Nonstandard Abbreviations and Acronyms

CO	cardiac output
CVP	central venous pressure
EDPVR	end-diastolic pressure–volume relationship
eSBV	estimated stressed blood volume
HFpEF	heart failure with preserved ejection fraction
SBV	stressed blood volume
TBV	total blood volume
UBV	unstressed blood volume

Beyond the fact that these hemodynamic responses to exercise have been applied as key diagnostic criteria for HFpEF, these abnormalities have also been shown to be important determinants of functional limitations^{2,5} and to correlate with mortality.⁶ However, the pathophysiological basis of these abnormalities in HFpEF is complex⁷ and not yet fully explained. Mechanistic studies comparing responses of patients with HFpEF and normal subjects to exercise have identified important

differences, including impaired systolic and diastolic reserve, impaired vasodilation, chronotropic incompetence, and increased atrial stiffness.⁸ Recently, we also demonstrated that pharmacologic manipulation of the stressed blood volume (SBV) may also be an appropriate target in HFpEF.⁹ The SBV represents the key component of the total blood volume above the unstressed blood volume (UBV), which determines the mean circulatory filling pressure. However, the relative contributions of these factors to exercise intolerance are unknown. Understanding which circulatory factor(s) are quantitatively most important could help focus efforts to identify appropriate therapeutic targets.

To address these critical questions, we first performed a comprehensive characterization of the hemodynamic responses to exercise in patients with HFpEF and normal controls. Observations were conducted at rest and during symptom-limited exertion, information relevant to daily life, rather than at a proportion of an arbitrarily predicted maximum workload. Importantly, this characterization included an assessment of SBV in HFpEF and its response to exertion for the first time. We then investigated the relative contributions of exercise-induced changes of ventricular and vascular mechanical properties to observed changes in central hemodynamics in normal subjects and patients with HFpEF. The results provide a clear and comprehensive explanation for why exercise results in marked increases of CO and small increases of CVP and PCWP in normal subjects, compared with marked increased CVP and PCWP with a small increase of CO in patients with HFpEF.

METHODS

The data that support the findings of this study are available from the corresponding author upon reasonable request.

This study included 60 patients referred for hemodynamic evaluation of unexplained dyspnea, in whom the diagnosis of HFpEF was confirmed, and 22 healthy volunteers. Patients with HFpEF were referred to the Department of Cardiology, Alfred Hospital for further investigation of symptoms consistent with a diagnosis of heart failure (New York Heart Association II–III) in the presence of an LVEF >50%. Exclusion criteria included significant coronary artery disease that had not been revascularized; moderate or greater aortic or mitral valve disease; infiltrative, restrictive, or hypertrophic myocardial disease; pericardial constriction; or significant right ventricular disease. The diagnosis of HFpEF was confirmed by the presence of an end-expiratory PCWP ≥ 15 mm Hg at rest or ≥ 25 mm Hg during symptom-limited exercise. Healthy control data were obtained from 15 subjects studied in the HemRex

(Effect of Age on the Hemodynamic Response During Rest and Exercise in Healthy Humans) study¹⁰ and from 7 subjects studied at the Department of Cardiology, Alfred Hospital. Healthy subjects were free from known cardiac or respiratory disease, with a normal echocardiogram and a normal hemodynamic profile that included a peak PCWP <25 mm Hg. The study was approved by the institutional ethics review committees, and all participants provided written informed consent.

Echocardiographic and Hemodynamic Measurements

Studies were conducted in the nonfasted state, and background medications were continued. Concurrent echocardiographic and hemodynamic studies were performed at rest and during exercise. Echocardiographic images were obtained by a trained cardiac sonographer, with the patient in the supine position on the cardiac catheterization table. The principal objective of the echocardiographic assessment in this study was to perform focused apical 2-chamber and 4-chamber imaging to assess the LVEF (LVEF_{echo}) at rest and at peak exercise. Hemodynamic evaluations were conducted using a 7F thermodilution catheter advanced via a brachial or internal jugular introducer sheath. Right atrial, right ventricular (RV), pulmonary arterial, and PCWP pressures were recorded at end-expiration, over a minimum of 3 cardiac cycles. CO was measured using the thermodilution method, and this was used to derive the stroke volume (SV_{thermo}). Systemic arterial blood pressure was measured noninvasively. Following the baseline evaluation, patients were instructed to commence supine cycle ergometry using a weight-adjusted workload protocol in which the resistance increased every 3 minutes. Echocardiographic images and hemodynamic data were obtained during peak symptom-limited exertion.

Calculated Parameters

Several parameters were derived from the measured echocardiographic and hemodynamic indices. Among these, standard derived variables included pulmonary vascular resistance, systemic vascular resistance, and stroke volume. Pulmonary artery compliance, systemic vascular compliance, effective arterial elastance, and effective pulmonary arterial elastance were calculated as described by us,^{11,12} together with the ratio of pulmonary arterial systolic pressure to stroke volume.

We determined the LVEDV from the relationship: $LVEDV = SV_{thermo} / LVEF_{echo}$, with subsequent calculation of the left ventricular end-systolic volume. Ventricular systolic properties were indexed by the ratio of the end-systolic pressure (P_{es}) and end systolic volume (ESV): $R_{es} = P_{es} / ESV$, which is a surrogate for end-systolic elastance (the slope of the end-systolic pressure–volume

relationship) when data are not available for determination of the volume axis intercept of the end-systolic pressure–volume relationship. Ventricular diastolic properties were assessed using the single beat method of estimating the end-diastolic pressure–volume relationship (EDPVR) from PCWP (which was assumed to be equal to left ventricular [LV] end-diastolic pressure) and LVEDV as detailed previously.¹³ Ventricular capacity was indexed by V_{30} , the predicated volume on the EDPVR at a filling pressure of 30 mm Hg, as previously described^{13,14} and as outlined in Data S1.

Estimated Stress Blood Volume Calculation

Measured hemodynamic parameters were used to estimate SBV. In brief, SBV is the portion of the total blood volume above the UBV that contributes to generation of the mean circulatory filling pressure. Direct measurement of SBV requires complex experimental preparations and maneuvers that are not readily applicable to humans, particularly during exercise. The estimated SBV (eSBV) is determined using a previously described computational simulation based on a generally accepted model of the cardiovascular system,^{9,15} as summarized in Data S1. In brief, patient-specific hemodynamic variables (including heart rate [HR], LVEF, CO, CVP, pulmonary artery pressures, PCWP, and systemic arterial pressures) serve as inputs to the model in which parameters (including LV and RV contractility, systemic and pulmonary vascular resistance, systemic and pulmonary compliance, and SBV) are adjusted to generate an optimal match between model estimates of the hemodynamic variables to the observed input values (Figure S1 and Figure S2). Importantly, in this study, eSBV is the only parameter derived from the computational model, whereas all other parameters were derived from direct measurements (Data S1 and Figure S3). For the estimation of eSBV, model fitting is performed after indexing CO to a body weight of 70 kg, and accordingly, eSBV is reported as milliliters per 70 kg.

Assessing the Contribution of Individual Exercise-Induced Changes of Cardiovascular Properties to the Hemodynamics of Exercise

The above-noted cardiovascular simulation was also used to assess the contribution of individual exercise-induced changes of cardiovascular properties to the hemodynamics of exercise in normal subjects and patients with HFpEF. Model parameters were initially set to simulate the average hemodynamic profile of normal subjects under resting conditions. Key parameters (HR, LV end-systolic elastance, RV end-systolic

elastance, LV EDPVR, pulmonary vascular resistance, systemic vascular resistance, and eSBV) were then individually changed to their respective values at peak exercise, and their impact on CVP, PCWP, and CO were noted. The parameters were then ranked in order of least to greatest effect on PCWP; parameter values were then changed sequentially in that order such that their cumulative effects on CVP, PCWP, and CO were determined. Finally, this entire process was repeated based on average hemodynamic variable values derived from the HFpEF cohort.

Statistical Analysis

Data are presented as mean±SD. Within- or between-group comparisons were performed using a paired or unpaired Student *t* test as appropriate. A *P* value of <0.05 was considered to be statistically significant. Univariate relationships between variables were examined by linear regression and by Pearson correlation coefficients. Statistical analysis was performed using IBM SPSS Statistics version 25 (IBM, Armonk, NY).

RESULTS

Patients with HFpEF were older (aged 70±8 years) than controls (aged 61±11 years old, *P*<0.001), and the proportion of women in the HFpEF group (48 women, 12 men) was greater than that in the control population (11 women, 11 men, *P*<0.01). Patients with HFpEF and controls had a similar body mass index (30±6 kg/m² versus 29±5 kg/m²) and LVEF (62%±5% versus 60%±7%). Atrial fibrillation was present in 10 patients with HFpEF and none of the controls. New York Heart Association class II symptoms were present in 38% of patients with HFpEF, and 62% had class III symptoms. A history of hypertension was present in 77% of patients with HFpEF. In the patients with HFpEF, background medications included angiotensin-converting enzyme/angiotensin receptor blockers (35%), β-blockers (32%), spironolactone (18%) and calcium channel blockers (15%), and diuretics (27%). Controls were not taking any cardiovascular medications. The peak workload capacity and exercise duration achieved by patients with HFpEF were significantly less than controls: 55±30 versus 99±40 W (*P*<0.001) and 6.4±0.4 versus 8.9±2.1 minutes (*P*=0.002), respectively.

Basic Hemodynamic Measures

Measured and derived hemodynamic parameters are summarized in Table 1 for healthy subjects and patients with HFpEF at rest and during exercise. As expected, patients with HFpEF exhibited higher PCWP at rest, and this difference was particularly evident during exercise. At rest, LVEF, LVEDV, and left ventricular

end-systolic volume were smaller in patients with HFpEF compared with control subjects. Although LVEF did not differ between groups at peak exercise, LV volumes were significantly smaller in patients with HFpEF compared with controls. For patients with HFpEF, there were statistically significant but quantitatively small exercise-induced increases in LVEDV and stroke volume. In contrast, there was a marked increase in LVEDV and stroke volume in controls during exercise. Left ventricular end-systolic volume did not change with exercise in either group. Given that systolic blood pressure increased considerably more in patients with HFpEF, the calculated R_{es} was significantly greater in patients with HFpEF.

Average Idealized Pressure–Volume Relationships

Changes of LV systolic and diastolic properties between rest and exercise are summarized in the idealized pressure–volume diagrams of Figure 1, which further illustrate the average values of volumes and pressures summarized in Table 1 at end-systole and end-diastole. R_{es} was greater in patients with HFpEF than in controls and increased during exercise only in the patients with HFpEF. During diastole, there was an exercise-related rightward shift of the average end diastolic volume:end diastolic pressure point in the control group, but there was no significant change in diastolic V_{30} , indicating that there was no statistically significant shift of the estimated EDPVR. In patients with HFpEF, there was an upward and rightward shift of the average EDV-EDP point and a statistically significant reduction of V_{30} , indicating a significant upward and leftward shift of the estimated EDPVR toward lower volumes. These figures graphically emphasize the difference in exercise-induced responses of the normal and HFpEF left ventricle.

As summarized in Table 1 and Figure 2, eSBV was greater in HFpEF than controls both at rest and during exercise. In addition, the change in eSBV from rest to exercise was also greater in patients with HFpEF than controls.

Circulatory Determinants of Rest and Exercise Hemodynamics

We performed 2 separate analyses to investigate how the fundamental indices of circulatory mechanics yield the observed hemodynamic parameters. First, we examined the simple univariate associations between circulatory parameters and hemodynamic measures. As shown in Table 2, PCWP and CVP were significantly correlated with eSBV and V_{30} at rest across the entire cohort. When considering the HFpEF cohort only, eSBV remained a significant determinant of each

Table 1. Resting Hemodynamic and Echocardiographic Parameters

	Control, n=22		HFpEF, n=60	
	Rest	Exercise	Rest	Exercise
Peak workload, W		99±40		55±30*
Heart rate, bpm	68±11	115±22 [†]	65±13	101±24 ^{†,‡}
Systolic BP, mm Hg	133±19	156±27 [†]	149±27*	174±30 ^{†,‡}
Diastolic BP, mm Hg	74±10	83±11 [†]	77 ± 14	89±18 [§]
Right atrial pressure, mm Hg	5±3	8±3 [†]	8±3*	16±4 ^{*,†}
PA systolic pressure, mm Hg	24±6	42±8 [†]	35±9*	61±11 ^{*,†}
PA mean pressure, mm Hg	15±4	29±6 [†]	23±6*	43±7 ^{*,†}
PCWP, mm Hg	8±3	16±5 [†]	13±4*	31±5 ^{*,†}
Cardiac index, L/min per m ²	2.92±0.59	7.14±1.89 [†]	2.5±0.6*	4.4±1.3 ^{*,†}
SVR	16.0±2.9	8.0±2.4 [†]	20.8±6.6*	15.7±6.0 ^{*,†}
PVR	1.3±0.7	1.0±0.7	2.1±1.0	1.6±0.8 [†]
PCWP/W, mm Hg/W per kg	N/A	15±6	N/A	59±35*
LV ejection fraction, %	60±7	67±7 [†]	62±5	67±5 [†]
LV end diastolic volume, mL	145±37	179±29 [†]	120±32	126±38 ^{*,§}
LV end-systolic volume, mL	59±20	58±11	46±14 [‡]	43±14*
LV R _{es}	2.32±1.15	2.50±0.63	3.14±1.05	3.79±1.01 ^{*,†}
V ₃₀ , mL	185±53	173±39	139±37*	121±34 ^{†,‡}
Ea _{sys}	1.44±0.38	1.20±0.29 [§]	1.98±0.8*	2.00±0.86*
Ea _{pul}	0.09±0.05	0.11±0.06 [§]	0.14±0.08*	0.17±0.12 ^{§,}
PA systolic/stroke vol.	0.30±0.09	0.36±0.13 [†]	0.52±0.22	0.80±0.32 ^{*,†}
eSBV	20.5±4.9	27.7±7.0 [†]	26.9±0.7*	40.9±3.7 ^{*,†}

BP indicates blood pressure; Ea_{pul}, pulmonary artery elastance; Ea_{sys}, systemic arterial elastance; eSBV, estimated stress blood volume; HFpEF, heart failure with preserved ejection fraction; LV, left ventricular; LV R_{es}, ratio of LV end-systolic pressure to end-systolic volume; PA, pulmonary artery; PCWP, pulmonary capillary wedge pressure; PVR, pulmonary vascular resistance; SVR, systemic vascular resistance; and V₃₀, LV volume at LV pressure of 30 mm Hg.

*P<0.001, resting or exercise values vs controls.

[†]P<0.001, within group rest vs exercise.

[‡]P<0.05, resting or exercise values vs controls.

[§]P<0.01, within group rest vs exercise.

^{||}P<0.05, within group rest vs exercise.

[¶]P<0.01, resting or exercise values vs controls.

parameter at rest. During exercise, the change in eSBV was strongly correlated with the increase in PCWP and CVP across the cohort and in the HFpEF group specifically. The rise in PCWP was also correlated with the exercise-induced change in V₃₀ in both the total cohort and patients with HFpEF. The exercise mediated rise in cardiac index across the entire cohort was modestly correlated with the change in eSBV and closely with the change in V₃₀. Exercise-induced changes in arterial elastance and ventricular contractility were not significantly correlated with hemodynamic indices in univariate analyses in general, other than a modest correlation between changes in arterial elastance and cardiac index over the whole cohort.

We next conducted a detailed cardiovascular simulation using average data presented in Table 1 to understand the relative contribution of changes of key parameters to exercise-induced changes of CO, CVP, and PCWP; comparisons were made between normal subjects and patients with HFpEF. First, we individually introduced changes of HR, LV R_{es}, RV R_{es}, LV EDPVR,

pulmonary vascular resistance, systemic vascular resistance, and eSBV between rest and exercise conditions and determined their effects on hemodynamics in normal subjects (Figure 3A through 3C); the horizontal dashed blue lines indicate the resting value of the respective variable, whereas the dashed green lines indicate the respective values attained at peak exercise. As seen, CVP did not rise appreciably in response to the change of any single parameter. Appreciable changes of PCWP were achieved with increases of either RV R_{es} or eSBV; the increase of PCWP achieved with the increase of eSBV alone reached the value observed at peak exercise. Note that some of the parameter changes actually resulted in small decreases of PCWP. The increase of eSBV also resulted in the largest increase of CO, but alone only accounted for a small portion of the final CO attained at peak exercise. Next, the circulatory parameters were sequentially modified from their resting values to their values during exercise to assess the stepwise cumulative effects of changes of all parameters (Figure 3D through 3F). As

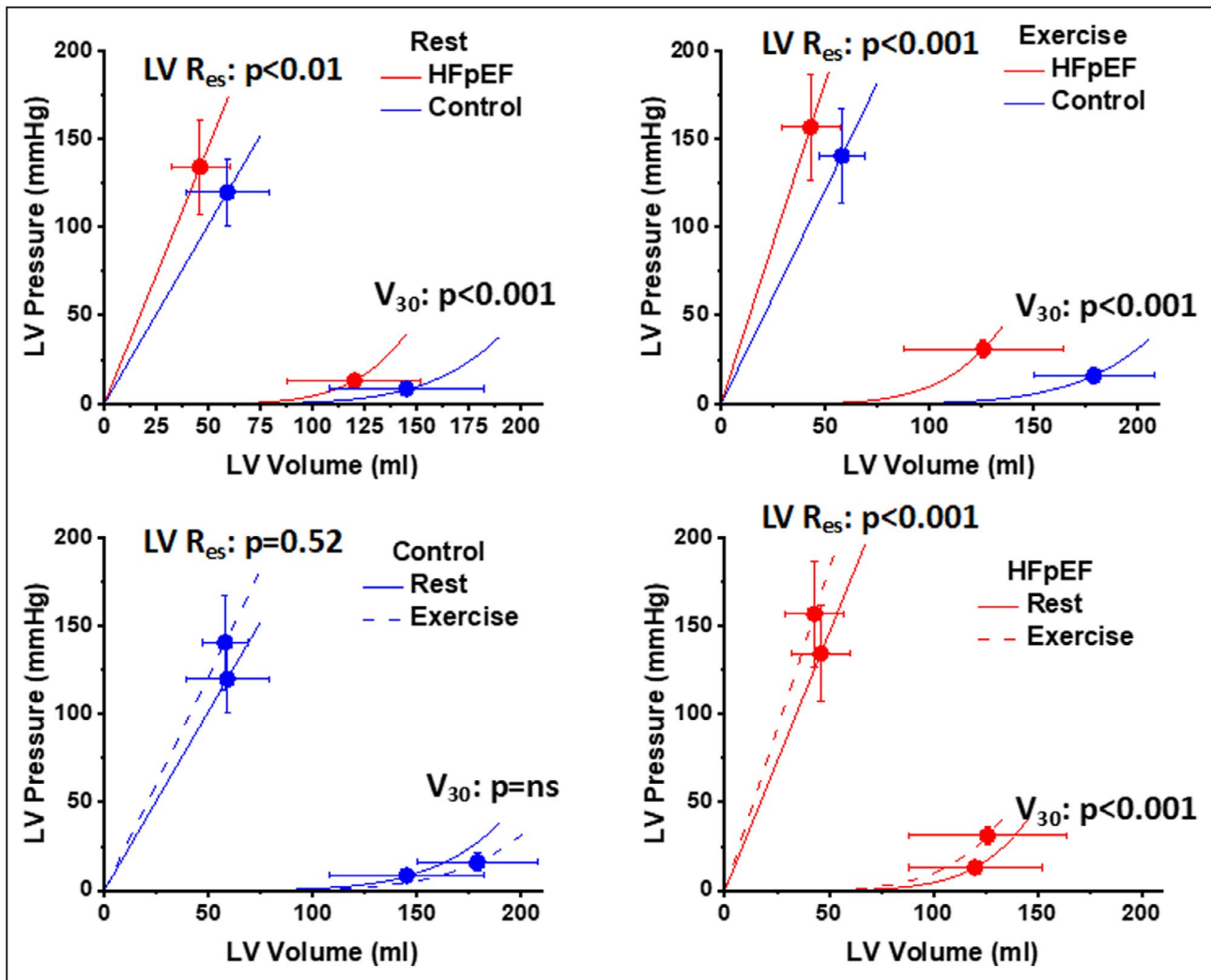

Figure 1. End-systolic and end-diastolic pressure volume points and derived relationships at rest and during exercise in controls and patients with heart failure with preserved ejection fraction (HFpEF). LV indicates left ventricular; $LV R_{es}$, ratio of LV end-systolic pressure: end-systolic volume; ns, not significant; and V_{30} , LV volume at LV pressure of 30 mm Hg.

in the original analysis, the main factor regulating CVP and PCWP was eSBV. In contrast to pressures, the effect of sequentially adjusting parameters to their values during exercise resulted in incremental increases of CO, with the greatest increase achieved with the final adjustment of eSBV. These findings indicate that there is a complex nonlinear interaction between the cardiovascular parameters in the determination of CVP, PCWP, and CO. For example, the full impact of increasing eSBV on CO are not realized unless the other exercise-induced changes of cardiovascular parameters are also in place.

Results of the same analysis performed on data from the HFpEF groups are shown in Figure 4. Changes in CVP and PCWP were almost exclusively attributable to the rise of eSBV. In contrast to normal, the increase in CO was much more dependent on increases of HR,

RV R_{es} , and less influenced by eSBV, despite the fact that the increase of eSBV from rest to exercise was 2 times larger than in controls.

To further elucidate the factor(s) that account for the difference in hemodynamic response to exercise between normal subjects and patients with HFpEF, model parameters were set to those of the patients with HFpEF during exercise and were then adjusted to those of normal subjects during exercise; parameter values were first varied individually (Figure 5A through 5C) and then sequentially (Figure 5C through 5F). eSBV had the greatest individual impact on CVP; LV EDPVR, eSBV, and systemic vascular resistance had the largest impact on PCWP (in that order), and CO was mainly influenced by the LV EDPVR. As with the other analyses, the cumulative effects of serial changes of parameters were nonlinear. Both CVP and PCWP achieved values of the

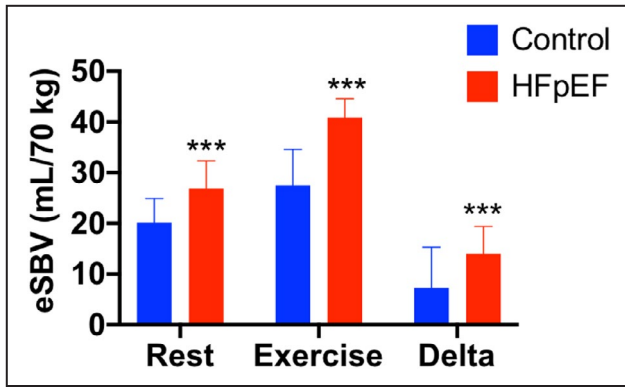

Figure 2. Bar graphs indicate estimated stressed blood volume (eSBV) at rest and during exercise, and the exercise-induced change. HFpEF indicates heart failure with preserved ejection fraction. *** $P < 0.001$.

controls by the combined effects of adjusting eSBV and the LV EDPVR to those of the controls; CO was normalized by adjusting, almost exclusively, the LV EDPVR.

DISCUSSION

Although the constellation of hemodynamic parameters that differ between patients with HFpEF and

normal subjects at rest and with exercise are well documented, no prior study has unraveled the relative contributions of their individual contributors to the marked elevations of cardiac filling pressures and limited increase of cardiac output. The results of the present study provide new insights into these aspects of exercise physiology by combining a comprehensive array of directly measured hemodynamic parameters with careful cardiovascular modeling techniques. In this manner, we were able to address questions that cannot be answered by direct experimental measurements alone.

In normal individuals, exercise results in marked increases of CO and small changes in CVP and PCWP. Increased SBV, amounting to ~500 mL for an average-sized individual, accounts for a majority of increased CO, with coordinated changes of several other vascular and ventricular properties contributing, collectively, a smaller portion. The increase of CO in normal subjects is possible because the EDPVR does not change significantly, and LVEDV increases significantly during exercise, which invokes the classic Frank-Starling mechanism to increase stroke volume. In contrast, CVP and PCWP increased dramatically in patients with HFpEF, whereas there was a relatively small increase of CO. The increases of CVP and PCWP were found to be predominantly attributable to increased SBV.

Table 2. Correlations Between Hemodynamic and Circulatory Parameters

Parameter	Resting hemodynamics					
	PCWP		CVP		Cardiac index	
	All	HFpEF	All	HFpEF	All	HFpEF
eSBV	$r=0.81, P<0.001$	$r=0.73, P<0.001$	$r=0.85, P<0.001$	$r=0.81, P<0.001$	$r=-0.07, P=0.55$	$r=0.13, P=0.31$
V_{30}	$r=-0.39, P=0.005$	$r=-0.15, P=0.27$	$r=-0.31, P=0.005$	$r=-0.16, P=0.22$	$r=0.62, P<0.001$	$r=0.60, P<0.001$
LV R_{es}	$r=0.11, P=0.34$	$r=-0.08, P=0.53$	$r=0.00, P=0.99$	$r=-0.13, P=0.32$	$r=-0.11, P=0.32$	$r=0.03, P=0.82$
Ea_{sys}	$r=0.18, P=0.09$	$r=0.01, P=0.94$	$r=0.11, P=0.34$	$r=0.02, P=0.89$	$r=-0.49, P<0.001$	$r=-0.45, P<0.001$

Parameter	Exercise hemodynamics					
	Δ PCWP		Δ CVP		Δ Cardiac index	
	All	HFpEF	All	HFpEF	All	HFpEF
Δ eSBV	$r=0.67, P<0.001$	$r=0.63, P<0.001$	$r=0.82, P<0.001$	$r=0.71, P<0.001$	$r=-0.23, P=0.04$	$r=0.02, P=0.87$
ΔV_{30}	$r=-0.44, P<0.001$	$r=-0.30, P=0.03$	$r=-0.33, P=0.006$	$r=-0.23, P=0.12$	$r=0.53, P<0.001$	$r=0.24, P=0.09$
Δ LV R_{es}	$r=0.18, P=0.14$	$r=0.21, P=0.15$	$r=-0.06, P=0.64$	$r=-0.16, P=0.29$	$r=-0.27, P=0.02$	$r=-0.03, P=0.81$
ΔEa_{sys}	$r=0.20, P=0.09$	$r=-0.04, P=0.76$	$r=0.23, P=0.05$	$r=0.14, P=0.35$	$r=-0.38, P=0.001$	$r=-0.21, P=0.15$

CVP indicates central venous pressure; Ea_{sys} , systemic arterial elastance; eSBV, estimated stressed blood volume; HFpEF, heart failure with preserved ejection fraction; LV R_{es} , ratio of left ventricular end-systolic pressure: end-systolic volume; PCWP, pulmonary capillary wedge pressure; and V_{30} , left ventricular volume at left ventricular pressure of 30 mm Hg.

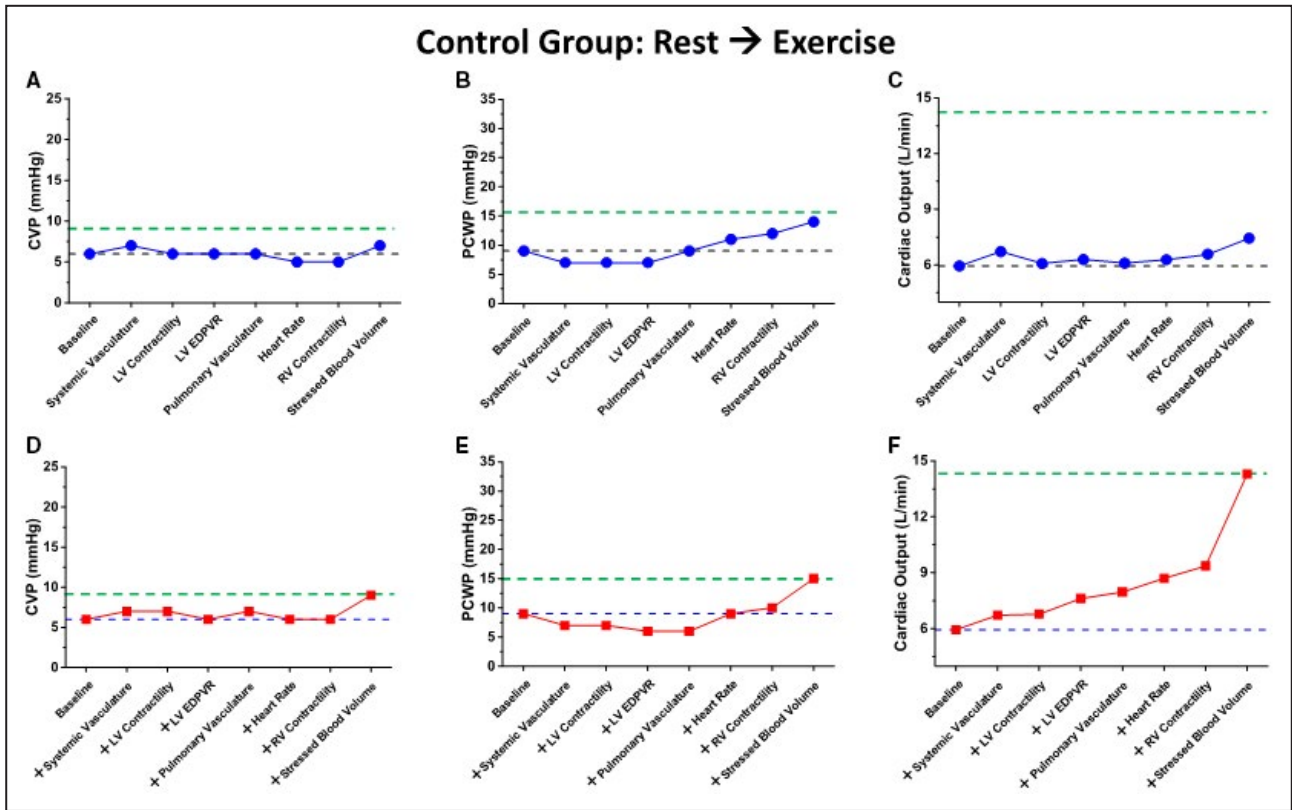

Figure 3. Physiologic basis for exercise hemodynamics in controls.

A through C, The individual impact of exercise-induced changes in specific circulatory variable on central venous pressure (CVP), pulmonary capillary wedge pressure (PCWP), and cardiac output (CO) relative to the baseline value represented by the blue dashed line. **D through F,** The cumulative effect of these changes on CVP, PCWP, and CO progressing toward the observed peak exercise levels (green dashed line). Data are derived from simulations based on group averaged values of the indicated parameters in control subjects. EDPVR indicates end-diastolic pressure-volume relationship; LV, left ventricular; and RV, right ventricular.

Compared with normal subjects, resting SBV is significantly higher in patients with HFpEF and increases approximately twice as much in response to exercise. Furthermore, patients with HFpEF appear to be more dependent on increases of HR to increase CO, though the HR response is blunted. Upon comparing cardiovascular parameters between normal subjects and patients with HFpEF at peak exercise, the main factor responsible for the marked increases of CVP and PCWP appears to be the larger increase of SBV. However, the main factor limiting the ability to increase CO is the inability of the left ventricle to increase EDV because of the upward-shifted EDPVR, despite the marked increase in PCWP. This has been observed previously and has been referred to as a failure of the Frank-Starling mechanism.¹⁶

When we compared effects of changing cardiovascular parameters individually versus changing them sequentially, it was revealed that the system is highly nonlinear in that the cumulative effects were not the sum of the individual effects, not for CVP, PCWP, or CO. This finding indicates that there are complex

nonlinear interactions between cardiovascular parameters in determining hemodynamic factors in an exquisitely orchestrated manner which, in normal subjects, results in large increases of CO and small increases of CVP and PCWP. In patients with HFpEF, the normal interdependencies are disrupted, resulting in abnormal hemodynamic responses that likely contribute to effort intolerance and may impact clinical outcomes.

First and foremost, the present study provides new information on the potential role of an increase in the SBV in patients with HFpEF. Previous studies have indicated the presence of an expanded total blood volume (TBV) expansion in HFpEF using radiotracer methodology,^{17,18} although this has not been a uniform finding. However, changes in TBV do not necessarily provide insights into changes in SBV. TBV is considered as being functionally divided into 2 components: UBV that fills the vascular system just below the inflection point of tension development in the vascular walls, whereas SBV represents the portion of TBV in excess of UBV that is responsible for generating pressure within each vascular compartment. Consistent with

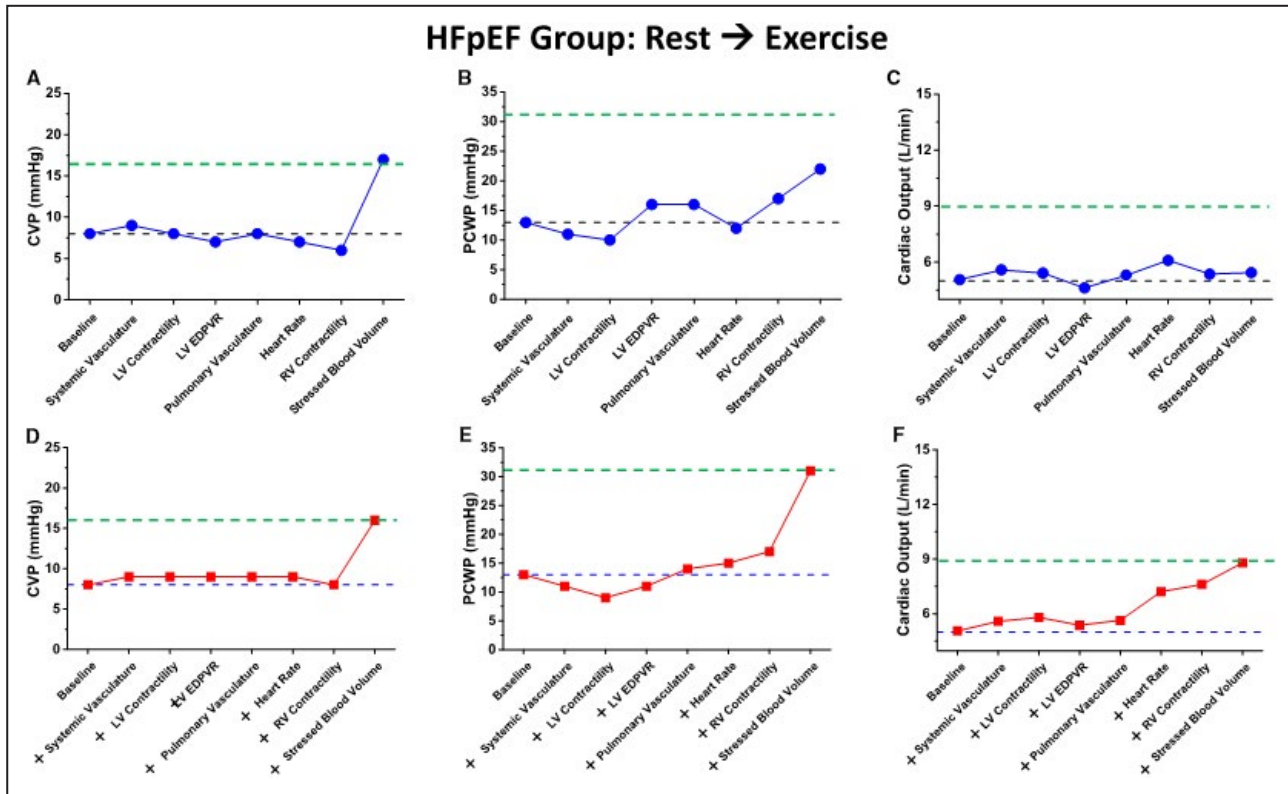

Figure 4. Physiologic basis for exercise hemodynamics in patients with heart failure with preserved ejection fraction (HFpEF).

A through **C**, Individual impact of exercise-induced changes in specific circulatory variable on central venous pressure (CVP), pulmonary capillary wedge pressure (PCWP), and cardiac output (CO) relative to the baseline value represented by the blue dashed line. **D** through **F**, The cumulative effect of these changes on CVP, PCWP, and CO progressing toward the observed peak exercise levels (green dashed line). Data are derived from simulations based on group averaged values of the indicated parameters in HFpEF subjects. EDPVR indicates end-diastolic pressure-volume relationship; LV, left ventricular; and RV, right ventricular.

this, we observed a strong correlation between eSBV and the resting PCWP and CVP. Mechanistically, the present study does not discern whether the increased SBV represents the presence of an expanded blood volume, reduced venous compliance, or most likely a combination of the 2 factors. Several factors could influence venous compliance in patients with HFpEF. These potentially include the vascular remodeling effects of increased venous pressure and neurohormonal activation, and the effects of extrinsic mechanical venous constraint, for example, by abdominal visceral fat.

As expected, we demonstrated that SBV increases in both controls and patients with HFpEF during exercise; naturally, these are in the setting of constant TBV within each cohort. Accordingly, the increase in eSBV during exercise represents the integrated effects of the redistribution of peripheral and splanchnic blood pools by muscular activity and increased sympathetic tone, respectively, resulting in a functional redistribution of the UBV to the SBV component.¹⁹ In addition to blood redistribution, the new finding of the present study is that the magnitude of this response was significantly

greater in patients with HFpEF compared with normal subjects. In this context it has been demonstrated that there is increased sympathetic tone in patients with HFpEF, even in the resting state.²⁰ However, differences of sympathetic tone in response to exertion have not been evaluated in patients with HFpEF compared with normal subjects, neither on a global nor regional basis. Accordingly, the larger exercise-induced increase of SBV in patients with HFpEF could be explained by greater splanchnic sympathetic drive during exertion. Alternatively, this could simply relate to the higher resting value of TBV and eSBV in patients with HFpEF.

Although the estimated EDPVR did not shift significantly between rest and exercise in normal subjects, we detected an exercise-induced upward/leftward shift in patients with HFpEF, a finding that is consistent with prior measurements.^{16,21} More recently, Rommel et al demonstrated a similar EDPVR response in both the left ventricle and right ventricle during handgrip exercise.²² In that study, minimal effects on ventricular volumes were observed likely because of the limited

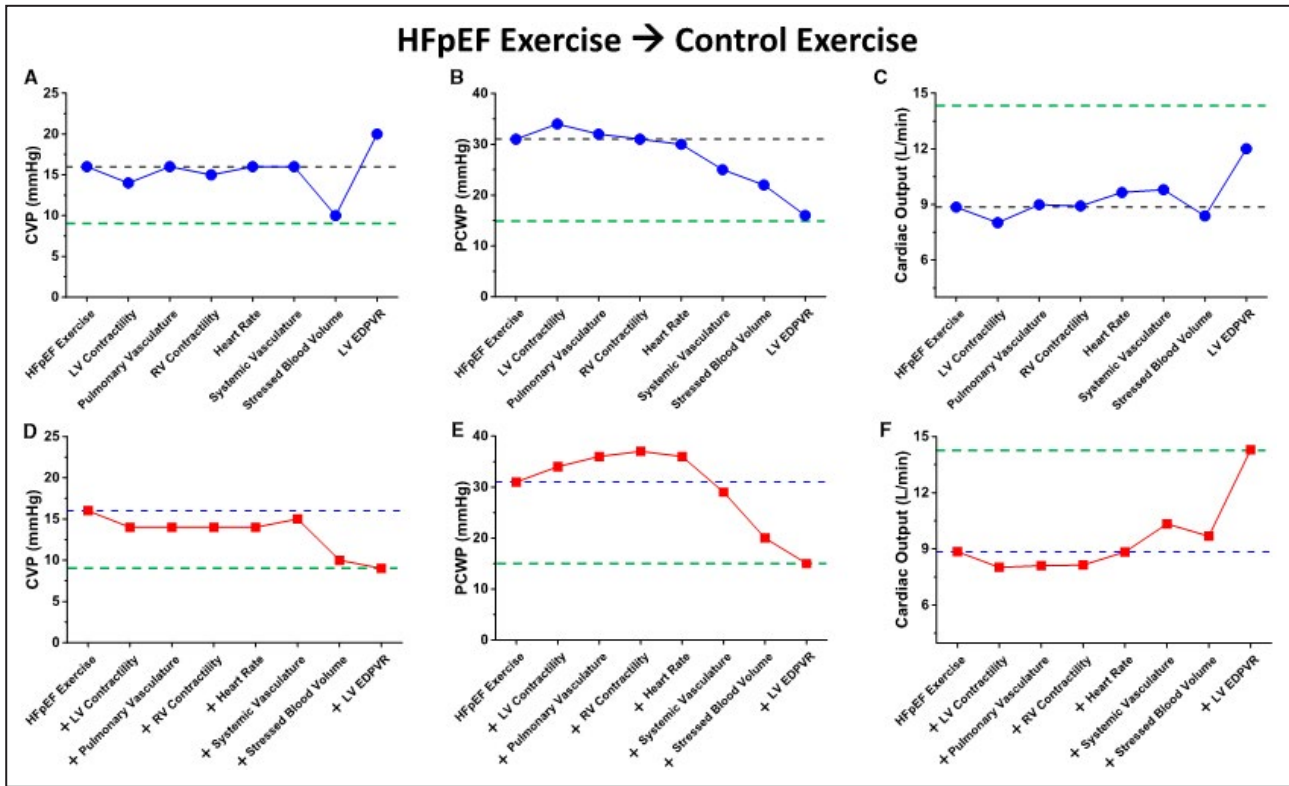

Figure 5. Plots demonstrate the hypothetical effect of converting circulatory parameters from heart failure with preserved ejection fraction (HFpEF) to control values on central venous pressure (CVP), pulmonary capillary wedge pressure (PCWP), and cardiac output (CO).

Data represent the individual effects (A through C) and cumulatively (D through F) on CVP, PCWP, and CO in HFpEF, relative to the peak observations in patients with HFpEF (blue dashed line) and control subjects (green dashed line). Data are derived from simulations based on group averaged values of the indicated parameters. EDPVR indicates end-diastolic pressure-volume relationship; LV, left ventricular; and RV, right ventricular.

effect of handgrip exercise on blood volume recruitment. In terms of mechanism, the EDPVR can be influenced by several factors, including the rate of relaxation (which is slowed in hypertrophy), interventricular interactions, and extrinsic constraints imposed by the pericardium and epicardial fat. With regard to the latter 2 factors, it is plausible that our finding of an acute and exaggerated increase of SBV during exercise results in marked volume loading of the right heart, which could negatively impact on LV chamber compliance via interventricular interactions, which would be amplified by pericardial and epicardial constraints.²³ Nevertheless, any of the noted factors alone or in combination could contribute to this finding. Regardless of mechanism(s), this reduction in LV capacity limited the ability to increase preload volume during exercise, resulting in a limited increase of stroke volume and cardiac output.

Overall, the data provide further impetus to evaluate the potential application of therapies that modify both the TBV and SBV, the latter at rest and during exertion. Diuretics are commonly used in patients with HFpEF.²⁴ Interestingly, the beneficial effect of pulmonary artery pressure monitoring in the CHAMPION trial, which

included patients with HFpEF, appeared to be largely related to consequent up-titration of diuretics,²⁵ suggesting that careful volume modification might exert favorable effects. Given the curvilinear relationship between TBV and venous filling pressure, it is difficult to estimate the precise hemodynamic effect of diuresis at an individual patient level, together with the further influences of exercise. Recently, we demonstrated that milrinone exerted favorable effects on symptoms in patients with HFpEF,²⁶ an effect potentially attributable to a reduction in SBV, which we speculated was because of the venodilatory effects of milrinone.⁹ By contrast, nitrates have not been shown to be beneficial in a formal clinical trial of patients with HFpEF.²⁷ Finally, splanchnic denervation created by pharmacologic blockade or surgical denervation has received increasing attention as a means of modifying SBV in heart failure patients.²⁸

As with previous studies, we observed that the peak heart rate was lower in patients with HFpEF than in normal subjects. Although we have previously identified that exercise capacity in patients with HFpEF is largely limited by the rise in PCWP,⁵ reduced cardiac output response also contributed, albeit to a lesser extent.

Conversely, Houstis and colleagues suggested that the contribution of reduced cardiac output to peak exercise capacity was relatively limited in comparison to the effects of impaired muscle diffusion, albeit with considerable complexity and heterogeneity between patients.²⁹ Consistent with this latter finding, we previously found that differences in peripheral oxygen extraction during exercise in younger versus older patients with HFpEF could not be explained by variations in cardiac output.³⁰ Limitations of the periphery to extract oxygen is just one of many other factors believed to contribute to limiting exercise capacity in patients with HFpEF.

Whether or not improving the cardiac output response to exercise would lead to increased exercise capacity in patients with HFpEF is unclear. We demonstrated that the cardiac output response to exercise could be augmented by milrinone, whereas at the same time, PCWP was decreased. However, this latter effect was mediated by a lesser exercise-induced increase of eSBV together with an increase in LV contractility during milrinone infusion.⁹ By contrast, β -adrenergic agonists, which produce venoconstriction, have been shown to exert limited inotropic effects in patients with HFpEF.³¹

Limitations

The results of the present study need to be interpreted within the context of its limitations. First, the values of stressed blood volume were estimated by adjusting several model parameters to fit measured hemodynamic parameters. Similarly, the relative contributions of key parameters to changes of cardiac filling pressures and cardiac output were explored using the same model. However, it must be recognized that there is no way to address these critical questions through direct experimental measurements. Second, there were differences between patients with HFpEF and normal subjects with regard to age and sex. In contrast to other studies in the literature, our healthy controls were volunteers recruited from the general community and had not been referred for investigation of dyspnea. Although the difference in age was significant, we do not believe the magnitude would be sufficient to account for the findings observed based on prior studies.³² Similarly, although the sex distribution of patients with HFpEF and controls differed, our prior studies would suggest that differences in sex distribution would not account for the current findings.³³ Furthermore, we believe that the utility of a multivariable analysis in the current study would be limited based on our demonstration that there are highly nonlinear interactions among the relevant circulatory parameters together with the modest sample size. Third, we did not perform a detailed echocardiographic assessment of mitral regurgitation or left atrial mechanics during exercise. Nevertheless,

we did not identify any patients who developed moderate or greater functional mitral regurgitation during exercise. Finally, the study was conducted across 2 sites. Although efforts were made to standardize methodologies, it is appreciated that some unrecognized differences could have contributed to systemic differences beyond those because of the different biological substrates, although the underpinning fundamental hemodynamic data used in the modeling procedures are consistent with our prior studies and those of others in the field.

CONCLUSIONS

This is the first study to comprehensively examine the relative contributions of circulatory parameters to rest and exercise hemodynamics in patients with HFpEF. Specifically, we delineated the prime role of increased stressed blood volume to the abnormal resting and exercise hemodynamics in patients with HFpEF. Patients with HFpEF had an ~25% higher resting eSBV compared with the control group, but eSBV increased by nearly twice as much during exercise. In patients with HFpEF, this finding, along with an important contribution of the upward/leftward shift of the EDPVR, explained the marked increase in PCWP during exercise in the group with HFpEF. The abnormal upward/leftward shift of the EDPVR was a key contributor to the limited exercise-induced increases of CO in patients with HFpEF. These findings may help focus attention on therapeutic targets, at least those that could be effective in normalizing resting hemodynamics and their responses to exercise in HFpEF. Such targets could include pharmacologic and device-based approaches that limit exercise-induced increases of SBV.

ARTICLE INFORMATION

Received April 8, 2021; accepted August 2, 2021.

Affiliations

Department of Cardiology, Alfred Hospital, Melbourne, Australia (D.M.K., S.N., J.M.); Heart Failure Research Group, Baker Heart and Diabetes Institute, Melbourne, Australia (D.M.K., S.N., J.M.); Department of Medicine, Monash University, Melbourne, Australia (D.M.K., S.N., J.M.); Department of Cardiology, Herlev-Gentofte Hospital, Copenhagen, Denmark (E.W.); Department of Cardiology, Rigshospitalet, University of Copenhagen, Denmark (C.H., F.G., J.E.M.); Department of Cardiology, Odense University Hospital, Denmark (J.E.M.); Department of Cardiovascular Medicine, Kyushu University School of Medicine, Fukuoka, Japan (K.S.); and Department of Medicine, Columbia University Medical School, New York, NY (D.B.).

Sources of Funding

The study was funded with support from the National Health and Medical Research Council of Australia.

Disclosures

D.M.K. reports receiving grants and consulting fees from Novartis, Bayer, and Corvia outside of the submitted work. J.M. has received grants and speaker's fees from Abiomed; and speaker's fees from Orion Pharma,

Novartis, and Boeinger Ingleheim outside submitted work. D.B. is cofounder of PV Loops LLC, which developed and distributes the Harvi cardiovascular simulation, and reports receiving consulting fees from Axon Therapies, Inc. and an institutional research grant from TENAX Therapeutics. The remaining authors have no disclosures to report.^{13,14}

Supplementary Material

Data S1

Figures S1–S3

References^{34–38}

REFERENCES

1. Yancy CW, Jessup M, Bozkurt B, Butler J, Casey DE Jr, Colvin MM, Drazner MH, Filippatos GS, Fonarow GC, Givertz MM, et al. 2017 ACC/AHA/HFSA focused update of the 2013 ACCF/AHA guideline for the management of heart failure: a report of the American College of Cardiology/American Heart Association Task Force on Clinical Practice Guidelines and the Heart Failure Society of America. *Circulation*. 2017;136:e137–e161.
2. Maeder MT, Thompson BR, Brunner-La Rocca HP, Kaye DM. Hemodynamic basis of exercise limitation in patients with heart failure and normal ejection fraction. *J Am Coll Cardiol*. 2010;56:855–863. doi: 10.1016/j.jacc.2010.04.040
3. Reddy YNV, Carter RE, Obokata M, Redfield MM, Borlaug BA. A simple, evidence-based approach to help guide diagnosis of heart failure with preserved ejection fraction. *Circulation*. 2018;138:861–870. doi: 10.1161/CIRCULATIONAHA.118.034646
4. Obokata M, Kane GC, Reddy YN, Olson TP, Melenovsky V, Borlaug BA. Role of diastolic stress testing in the evaluation for heart failure with preserved ejection fraction: a simultaneous invasive-echocardiographic study. *Circulation*. 2017;135:825–838. doi: 10.1161/CIRCULATIONAHA.116.024822
5. Wolsk E, Kaye D, Komtebedde J, Shah SJ, Borlaug BA, Burkhoff D, Kitzman DW, Lam CSP, van Veldhuisen DJ, Ponikowski P, et al. Central and peripheral determinants of exercise capacity in heart failure patients with preserved ejection fraction. *JACC Heart Fail*. 2019;7:321–332. doi: 10.1016/j.jchf.2019.01.006
6. Dorfs S, Zeh W, Hochholzer W, Jander N, Kienzle RP, Pieske B, Neumann FJ. Pulmonary capillary wedge pressure during exercise and long-term mortality in patients with suspected heart failure with preserved ejection fraction. *Eur Heart J*. 2014;35:3103–3112. doi: 10.1093/eurheartj/ehu315
7. Houstis NE, Lewis GD. Causes of exercise intolerance in heart failure with preserved ejection fraction: searching for consensus. *J Card Fail*. 2014;20:762–778. doi: 10.1016/j.cardfail.2014.07.010
8. Pfeffer MA, Shah AM, Borlaug BA. Heart failure with preserved ejection fraction in perspective. *Circ Res*. 2019;124:1598–1617. doi: 10.1161/CIRCRESAHA.119.313572
9. Kaye DM, Byrne M, Mariani J, Nanayakkara S, Burkhoff D. Identification of physiologic treatment targets with favourable haemodynamic consequences in heart failure with preserved ejection fraction. *ESC Heart Fail*. 2020;7:3685–3693. doi: 10.1002/ehf2.12908
10. Wolsk E, Bakkestrom R, Thomsen JH, Balling L, Andersen MJ, Dahl JS, Hassager C, Moller JE, Gustafsson F. The influence of age on hemodynamic parameters during rest and exercise in healthy individuals. *JACC Heart Fail*. 2017;5:337–346.
11. Beale AL, Nanayakkara S, Kaye DM. Impact of sex on ventricular-vascular stiffness and long-term outcomes in heart failure with preserved ejection fraction: TOPCAT trial substudy. *J Am Heart Assoc*. 2019;8:e012190.
12. Brener MI, Burkhoff D, Sunagawa K. Effective arterial elastance in the pulmonary arterial circulation: derivation, assumptions, and clinical applications. *Circ Heart Fail*. 2020;13:e006591.
13. Klotz S, Dickstein ML, Burkhoff D. A computational method of prediction of the end-diastolic pressure-volume relationship by single beat. *Nat Protoc*. 2007;2:2152–2158. doi: 10.1038/nprot.2007.270
14. Klotz S, Hay I, Dickstein ML, Yi GH, Wang J, Maurer MS, Kass DA, Burkhoff D. Single-beat estimation of end-diastolic pressure-volume relationship: a novel method with potential for noninvasive application. *Am J Physiol Heart Circ Physiol*. 2006;291:H403–H412.
15. Burkhoff D, Dickstein M, Schleicher T. Harvi - Online. 2019.
16. Kitzman DW, Higginbotham MB, Cobb FR, Sheikh KH, Sullivan MJ. Exercise intolerance in patients with heart failure and preserved left ventricular systolic function: failure of the Frank-Starling mechanism. *J Am Coll Cardiol*. 1991;17:1065–1072. doi: 10.1016/0735-1097(91)90832-T
17. Maurer MS, King DL, El-Khoury Rumbarger L, Packer M, Burkhoff D. Left heart failure with a normal ejection fraction: identification of different pathophysiologic mechanisms. *J Card Fail*. 2005;11:177–187. doi: 10.1016/j.cardfail.2004.10.006
18. Miller WL, Mullan BP. Volume overload profiles in patients with preserved and reduced ejection fraction chronic heart failure: are there differences? A pilot study. *JACC Heart Fail*. 2016;4:453–459. doi: 10.1016/j.jchf.2016.01.005
19. Rothe CF. Reflex control of veins and vascular capacitance. *Physiol Rev*. 1983;63:1281–1342. doi: 10.1152/physrev.1983.63.4.1281
20. Verloop WL, Beeftink MM, Santema BT, Bots ML, Blankenstijn PJ, Cramer MJ, Doevendans PA, Voskuil M. A systematic review concerning the relation between the sympathetic nervous system and heart failure with preserved left ventricular ejection fraction. *PLoS One*. 2015;10:e0117332.
21. Borlaug BA, Jaber WA, Ommen SR, Lam CSP, Redfield MM, Nishimura RA. Diastolic relaxation and compliance reserve during dynamic exercise in heart failure with preserved ejection fraction. *Heart*. 2011;97:964–969. doi: 10.1136/hrt.2010.212787
22. Rommel KP, von Roeder M, Oberueck C, Latuscynski K, Besler C, Blazek S, Stiermaier T, Fengler K, Adams V, Sandri M, et al. Load-independent systolic and diastolic right ventricular function in heart failure with preserved ejection fraction as assessed by resting and handgrip exercise pressure-volume loops. *Circ Heart Fail*. 2018;11:e004121.
23. Borlaug BA, Reddy YNV. The role of the pericardium in heart failure: implications for pathophysiology and treatment. *JACC Heart Fail*. 2019;7:574–585.
24. Solomon SD, McMurray JJV, Anand IS, Ge J, Lam CSP, Maggioni AP, Martinez F, Packer M, Pfeffer MA, Pieske B, et al. Angiotensin-neprilysin inhibition in heart failure with preserved ejection fraction. *N Engl J Med*. 2019;381:1609–1620. doi: 10.1056/NEJMoa1908655
25. Abraham WT, Adamson PB, Bourge RC, Aaron MF, Costanzo MR, Stevenson LW, Strickland W, Neelaguru S, Raval N, Krueger S, et al. Wireless pulmonary artery haemodynamic monitoring in chronic heart failure: a randomised controlled trial. *Lancet*. 2011;377:658–666. doi: 10.1016/S0140-6736(11)60101-3
26. Nanayakkara S, Byrne M, Mak V, Carter K, Dean E, Kaye DM. Extended-release oral milrinone for the treatment of heart failure with preserved ejection fraction. *J Am Heart Assoc*. 2020;9:e015026. doi: 10.1161/JAHA.119.015026
27. Redfield MM, Anstrom KJ, Levine JA, Koepf GA, Borlaug BA, Chen HH, LeWinter MM, Joseph SM, Shah SJ, Semigran MJ, et al. Isosorbide mononitrate in heart failure with preserved ejection fraction. *N Engl J Med*. 2015;373:2314–2324. doi: 10.1056/NEJMoa1510774
28. Fudim M, Jones WS, Boortz-Marx RL, Ganesh A, Green CL, Hernandez AF, Patel MR. Splanchnic nerve block for acute heart failure. *Circulation*. 2018;138:951–953. doi: 10.1161/CIRCULATIONAHA.118.035260
29. Houstis NE, Eisman AS, Pappagianopoulos PP, Wooster L, Bailey CS, Wagner PD, Lewis GD. Exercise intolerance in heart failure with preserved ejection fraction: diagnosing and ranking its causes using personalized O₂ pathway analysis. *Circulation*. 2018;137:148–161. doi: 10.1161/CIRCULATIONAHA.117.029058
30. Nanayakkara S, Haykowsky M, Mariani J, Van Empel V, Maeder MT, Vizi D, Kaye DM. Hemodynamic profile of patients with heart failure and preserved ejection fraction vary by age. *J Am Heart Assoc*. 2017;6:e005434. doi: 10.1161/JAHA.116.005434
31. Norman HS, Oujiri J, Larue SJ, Chapman CB, Margulies KB, Sweitzer NK. Decreased cardiac functional reserve in heart failure with preserved systolic function. *J Card Fail*. 2011;17:301–308. doi: 10.1016/j.cardfail.2010.11.004
32. van Empel VP, Kaye DM, Borlaug BA. Effects of healthy aging on the cardiopulmonary hemodynamic response to exercise. *Am J Cardiol*. 2014;114:131–135. doi: 10.1016/j.amjcard.2014.04.011
33. Beale AL, Nanayakkara S, Segan L, Mariani JA, Maeder MT, van Empel V, Vizi D, Evans S, Lam CSP, Kaye DM. Sex differences in heart failure with preserved ejection fraction pathophysiology: a detailed invasive hemodynamic and echocardiographic analysis. *JACC Heart Fail*. 2019;7:239–249.
34. Burkhoff D, Tyberg JV. Why does pulmonary venous pressure rise following the onset of left ventricular dysfunction: a theoretical analysis. *Am J Physiol*. 1993;265:H1819–H1828.

-
35. Doshi D, Burkhoff D. Cardiovascular simulation of heart failure pathophysiology and therapeutics. *J Card Fail.* 2016;22:303–311. doi: 10.1016/j.cardfail.2015.12.012
 36. Uemura K, Sugimachi M, Kawada T, Kamiya A, Jin Y, Kashihara K, Sunagawa K. A novel framework of circulatory equilibrium. *Am J Physiol Heart Circ Physiol.* 2004;286:H2376–H2385.
 37. Morley D, Litwak K, Ferber P, Spence P, Dowling R, Meyns B, Griffith B, Burkhoff D. Hemodynamic effects of partial ventricular support in chronic heart failure: results of simulation validated with in vivo data. *J Thorac Cardiovasc Surg.* 2007;133:21–28. doi: 10.1016/j.jtcvs.2006.07.037
 38. Kaye D, Shah SJ, Borlaug BA, Gustafsson F, Komtebedde J, Kubo S, Magnin C, Maurer MS, Feldman T, Burkhoff D. Effects of an interatrial shunt on rest and exercise hemodynamics: results of a computer simulation in heart failure. *J Card Fail.* 2014;20:212–221. doi: 10.1016/j.cardfail.2014.01.005

SUPPLEMENTAL MATERIAL

Data S1.

Cardiovascular Model: Additional Details

The cardiovascular system was modeled according to the electrical analog shown below in Figure S1.

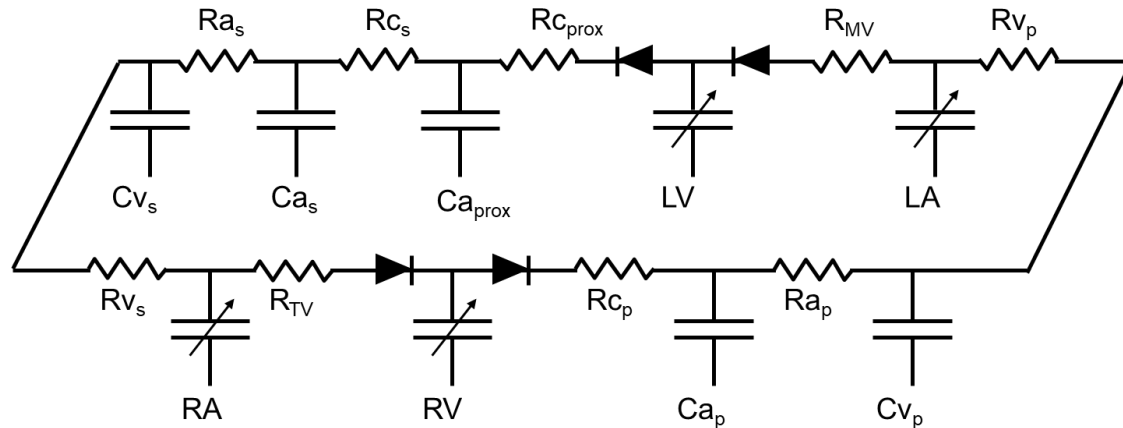

Figure S1: Circulatory model comprising characteristic proximal aorta, arterial and pulmonary resistance ($R_{C_{prox}}$, R_{C_s} and R_{C_p}), arterial and pulmonary vascular resistance (R_{A_s} and R_{A_p}), resistance to venous return (R_{V_s} and R_{V_p}), systemic and pulmonary arterial and venous compliance (C_{A_s} and C_{A_p} , C_{V_s} and C_{V_p}) and LA, LV, RA and RV chambers

The details of this model have been reported previously (34,35). Ventricular and atrial pumping characteristics were represented by modifications of the time-varying elastance $[(E(t))]$ theory of chamber contraction which relates instantaneous ventricular pressure $[P(t)]$ to instantaneous ventricular volume $[V(t)]$. Thus, for each chamber:

$$P(t) = P_{ed}(V) + [1-e(t)] P_{es}(V)$$

where:

$$P_{ed}(V) = \beta (e^{\alpha(V-V_0)} - 1)$$

$$P_{es}(V) = E_{es} (V - V_0)$$

and

$$e(t) = \frac{1}{2} \{ \sin[(\pi/T_{max})t - \pi/2] + 1 \} \quad 0 < t \leq 3/2 T_{max}$$

$$\frac{1}{2} e^{-(t-3/2T_{max})/\tau} \quad t > 3/2 T_{max}$$

where $P_{ed}(V)$ is end-diastolic pressure as a function of volume, $P_{es}(V)$ is end-systolic pressure as a function of volume, E_{es} is end-systolic elastance, V_0 is the volume axis intercept of the end-systolic pressure-volume relationship (ESPVR), α and β are parameters of the end-diastolic pressure-volume

relationship (EDPVR), T_{max} is the point of maximal chamber elastance, τ is the time constant of relaxation and t is the time during the cardiac cycle.

The systemic and pulmonary circuits are each modeled by a series of arterial and venous capacitances ($C_{a,prox}$, C_a and C_v), and resistances ($R_{c,prox}$, R_c , R_a and R_v). $R_{c,prox}$ and R_c mainly relate to stiffness of the proximal large conduit arterial vessels, R_a mainly relates to peripheral arterial resistance, and R_v , which is similar though not identical to Guyton's resistance to venous return (6). The heart valves permit flow in only one direction through the circuit.

One variable that is not explicitly noted in this model, is the stressed blood volume (SBV) which is the sum of the volumes on all of the capacitive elements depicted in the diagram. The total blood volume (TBV) contained within the vascular system is divided functionally into two pools: the *unstressed* blood volume (UBV) and the *stressed* blood volume (SBV). UBV, sometimes referred to as the *dead volume*, is defined as the maximum volume of blood that can be placed within the vasculature without raising its pressure above 0 mmHg. The blood volume in excess of UBV is SBV, so that $TBV=UBV+SBV$. The UBV of the entire vascular system is equal to the sum of UBV of all the individual capacitive compartments; similarly, the total body SBV is the sum of SBV for all compartments (7). While in the simplest implementation of the simulation, the pressure within the compartment is assumed to rise linearly with SBV, in recognition vascular pressure-volume relations are nonlinear when investigated in the higher pressure ranges (as encountered in HFpEF patients during exercise), systemic and pulmonary venous compartments were modeled by nonlinear pressure-volume relationships.

The circulatory model is represented mathematically by 8 simultaneous differential equations that can be solved numerically in real time. This model has been implemented in a software called "Harvi" (15). For a given set of parameter values, the model provides values for cardiac output, systemic and pulmonary pressures (e.g., aortic systolic/diastolic/mean, pulmonary systolic/diastolic/mean, central venous and pulmonary venous pressures), and ventricular volumes and ejection fractions (10 discrete parameters in all) among many other common cardiovascular parameters. Various versions of this model have been used for decades and has been validated to describe hemodynamics in a variety of disease states (34, 36-38). Group data were used to derive the parameters for the conditions of rest and exercise in health and HFpEF subjects.

Relevant to the current paper, we have also solved the "inverse problem." That is, we developed an algorithm which determines the values of the model parameters (including estimated SBV) given a set of pressures, flows and ejection fraction; this is referred to as the "Patient Fitting Algorithm." To validate the Patient Fitting Algorithm for this study, we first showed that the algorithm was able to successfully match the patient data. The following graph (Figure S2) shows the final model output values compared to the inputs to the Patient Fitting Algorithm for CO, CVP, PCWP, PA S/D/M, AoP S/D/M.

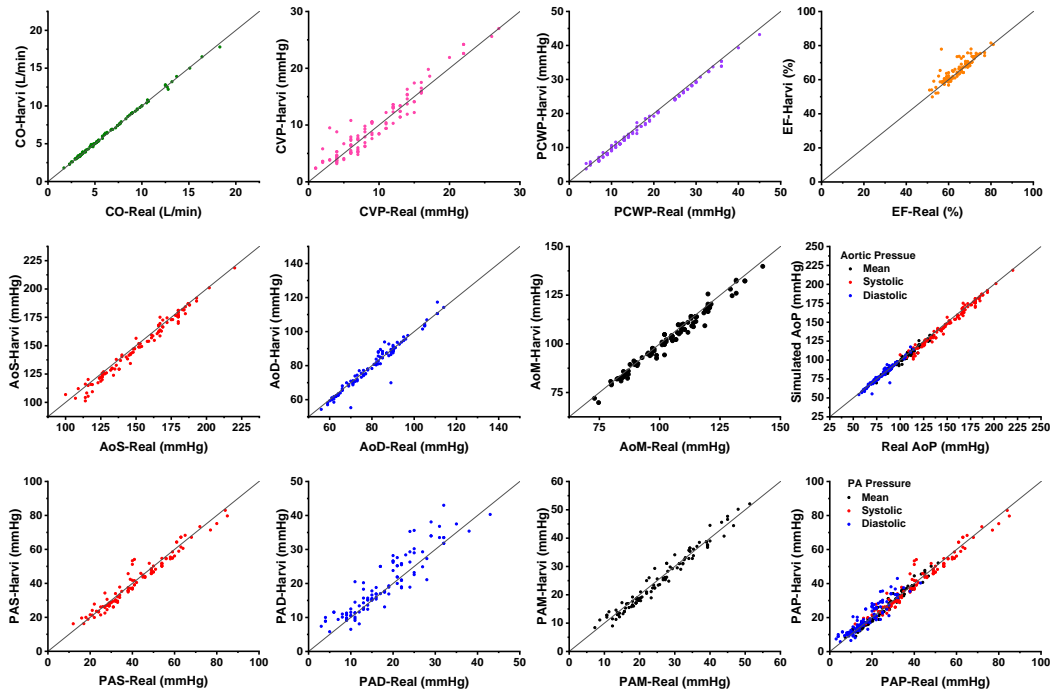

Figure S2. Comparison of model-fit output variables to those that served as inputs to the Patient Fitting Algorithm (solid lines are lines of identity).

As seen, there is an extremely tight correlation along the line of identity for each of the output parameters over an extremely broad range of real-world hemodynamic conditions. This indicates that the Patient Fitting Algorithm can successfully adjust model parameters to match individual patient hemodynamic profiles with a high degree of accuracy.

The second step of the validation involves cross validation of estimating stressed blood volume in comparison to an analytical equation that is based on a similar (though not identical) model of the cardiovascular system which itself has been validated in a preclinical model (36). Arising from the preclinical study, it was proposed that stress blood volume can be estimated the following equation:

$$eSBV \text{ (ml/kg)} = (\text{CO} + 19.61 \cdot \text{CVP} + 3.49 \cdot \text{PCWP}) \cdot 0.129$$

where eSBV is estimated stressed blood volume and CO is expressed in ml/kg/min. We compared this validated, analytical approach for estimating SBV to that provided in the individual patient entries detailed above. The results are shown by the blue dots in Figure S3 (the solid line is the regression line and the dotted line is the line of identity).

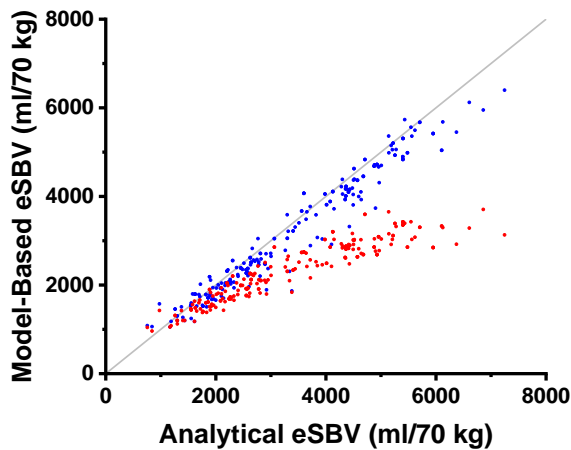

Figure S3. Comparison of estimated stressed blood volume (eSBV) between the validated analytical approach and the Harvi model-based approach with linear (blue dots) and nonlinear (red dots) venous compliances.

As seen, there was a high degree of correlation overall, however one of the assumptions in the analytical approach is that the relationship between pressure and volume in the venous system is linear. While this assumption has been validated in a large number of preclinical models, it is noteworthy that all such preclinical studies were performed in normal animals; not in states of heart failure in particular where CVP and PCWP can reach high values as shown in Fig. S2 above. As a result, values provided by the analytical approach can reach very high, unrealistic values in cases where CVP and PCWP are elevated (>5L). In contrast, in the Harvi model-based approach, nonlinear venous pressure-volume relationships can be introduced. Accordingly, nonlinearities started to be introduced into the systemic venous compliance when CVP increased above ~12 mmHg and in the pulmonary venous compliance when PCWP increased above ~15 mmHg. Since, overall, a bulk of the stressed blood volume resides in the systemic venous compliance, it is that nonlinearity that is the main driver in determining differences in eSBV. The red dots in the Fig. S3 above show the relationship between the linear-based analytical estimates and those arrived at by the Harvi model with nonlinear venous compliances.

In summary, the Patient Fitting Algorithm successfully adjusts model parameters to match 10 key, discrete cardiovascular parameters. It provides accurate estimates of eSBV when compared to a validated analytical approach when linear venous compliances are used in the model. Introduction of nonlinearities at central venous pressures above normal yields eSBV values more commensurate total blood volumes in normal individuals.

Derivation of V_{30}

In brief, the EDPVR is assumed to take the form of $EDP = \alpha EDV^\beta$. As detailed and validated previously (39, 40) the values of α and β are determined from the following sequence of equations:

$$\begin{aligned} V_0 &= EDV * (0.6 - 0.006 * EDP) \\ V_{30} &= V_0 + (EDV - V_0) / (EDP / 27.8)^{1/2.76} \\ \beta &= \log(EDP / 30) / \log(EDV / V_{30}) \end{aligned}$$

$$\alpha = 30/V_{30}^{\beta}$$

$$EDP = \alpha EDV^{\beta}$$